

Submittal Package

**Engineering Specification, Installation, Operation and Maintenance
Series LFM113-41 / LFM6113-41**

Pump Control Valve with Rate-of-Flow Feature

Sizes: 1¼" to 24"

⚠ WARNING



Read this Manual **BEFORE** using this equipment. Failure to read and follow all safety and use information can result in death, serious personal injury, property damage, or damage to the equipment. Keep this Manual for future reference.

THINK SAFETY FIRST

⚠ WARNING

Local building or plumbing codes may require modifications to the information provided. You are required to consult the local building and plumbing codes prior to installation. If the information provided here is not consistent with local building or plumbing codes, the local codes should be followed. This product must be installed by a licensed contractor in accordance with local codes and ordinances.

⚠ WARNING

Need for Periodic Inspection/Maintenance: This product must be tested periodically in compliance with local codes, but at least once per year or more as service conditions warrant. All products must be retested once maintenance has been performed. Corrosive water conditions and/or unauthorized adjustments or repair could render the product ineffective for the service intended. Regular checking and cleaning of the product's internal and external components helps assure maximum life and proper product function.

NOTICE

For Australia and New Zealand: Pipeline strainers should be installed between the upstream shutoff valve and the inlet of the backflow preventer.

It's important that this device be tested periodically in compliance with local codes, but at least once per year or more as service conditions warrant. If installed on a fire sprinkler system, all mechanical checks, such as alarm checks and backflow preventers, should be flow tested and inspected internally in accordance with NFPA 13 and NFPA 25.

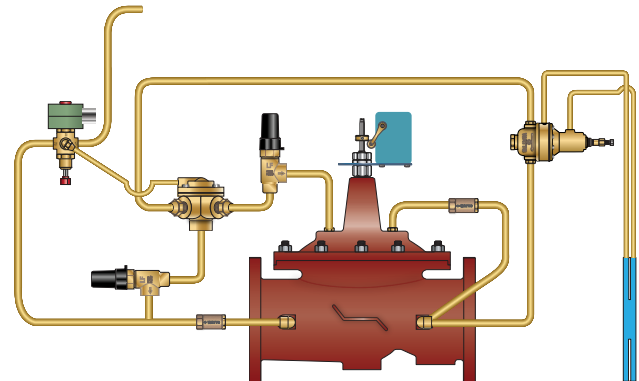

LFM113-41

Table of Contents	Page
Engineering Specifications	
ACV Schematic	2
Basic Valves	3
Standard Components	7
Optional Components	16
Installation, Operation and Maintenance	
Installation	18
Valve Servicing Dimensions	18
Commissioning the Pump Control Valve	19
ACV Maintenance Schedule	21
Troubleshooting Guide	22
Valve Disassembly Instructions	23

Watts product specifications in U.S. customary units and metric are approximate and are provided for reference only. For precise measurements, please contact Watts Technical Service. Watts reserves the right to change or modify product design, construction, specifications, or materials without prior notice and without incurring any obligation to make such changes and modifications on Watts products previously or subsequently sold.



LEAD FREE*

Series LFM113-41

Pump Control Valve with Rate-of-Flow Feature

Full Port Ductile Iron Single Chamber Valve

Features

- Opens at adjustable rate on pump start-up
- Closes at adjustable rate on pump shut-off
- Limit Switch turns pump off when valve closes
- Throttles to maintain constant Rate-of-Flow
- Orifice Plate Assembly is remote mounted (field installed)
- Hydraulic Check Feature prevents flow reversal
- Solenoid equipped with Manual Operator
- Rate-of-Flow setpoint is adjustable

Standard Components

- 1 – Main Valve (M100 - Single Chamber)
- 2 – Model 22 Accelerator Control
- 3 – Limit Switch
- 4 – 3-Way Solenoid
- 5 – Check Valve
- 6 – Adjustable Opening Speed
- 7 – Adjustable Closing Speed
- 8 – Rate-of-Flow Control
- 9 – Orifice Plate Assembly
- Y – Y-Strainer
- X – Isolation Cocks

Options and Accessories

- FC – Flo-Clean Strainer
- L – Dual Limit Switch

Operation

The Pump Control Valve with Rate-of-Flow Feature is designed to minimize the surges associated with the starting and stopping of pumps. The valve slowly opens and closes as required to control pumping related surges, and throttles to maintain a maximum flow rate during the pumping cycle. The pump starts and stops against a closed valve.

Pump Start Up: When the pump is signaled to start, the 3-Way Solenoid is energized, directing pressure into the cover chamber of the 3-way Accelerator Pilot. The Accelerator Pilot allows the main valve cover chamber to be vented downstream, causing the valve to open at a controlled rate, gradually admitting pumping pressure into the distribution system. The rate of opening is controlled by the adjustable opening speed control, which restricts the speed of fluid and pressure evacuating the main valve cover chamber. The valve remains open during the pumping cycle.

Rate-of-Flow Feature: During the pumping cycle, the valve acts as a Rate-of-Flow Control Valve. Throttling (Flow Control) action is controlled by a normally open, differential control pilot designed to: 1) Open (allowing fluid out of the main valve cover chamber) when the differential pressure across the orifice plate is below the adjustable set point, and, 2) Close (allowing fluid to fill the main valve cover chamber through the integral orifice of the Accelerator Pilot) when the differential pressure across the orifice plate is above the adjustable set point. A decrease in differential pressure causes the valve to modulate towards an open position, increasing flow rate. An increase in differential pressure causes the valve to modulate towards a closed position, decreasing flow rate.

The Orifice Plate Assembly should be installed three to five pipe diameters downstream of the Pump Control Valve, and field connected with 3/8" minimum copper tubing in accordance with factory piping schematic. **Please specify desired flow rate prior to ordering.**

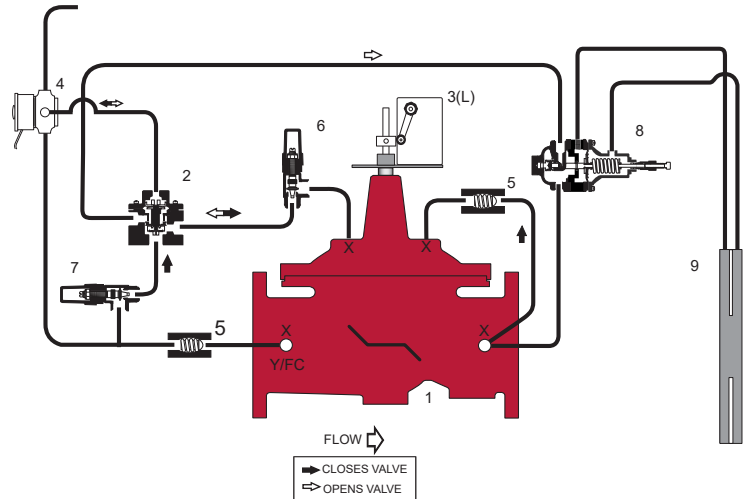

Pump Shutdown: When the pump is signaled to turn off, the 3-Way Solenoid is de-energized, venting the cover chamber of the 3-way Accelerator Pilot. The Accelerator Pilot allows the main valve cover chamber to be connected to upstream pressure, causing the valve to close at a controlled rate. The valve slowly begins to close while the pump continues to operate. The closing rate of the valve is controlled by the adjustable closing speed control, which restricts the speed of fluid and pressure entering the main valve cover chamber. When the valve reaches the closed position, the limit switch is actuated, turning the pump off.

Hydraulic Check Feature: When the pump is turned off and downstream pressure is greater than upstream pressure, downstream pressure is admitted to the main valve cover chamber through a check valve in the pilot control system, closing the valve, preventing reversal of flow.

Manual Operation: Engaging the Solenoid Manual operator simulates power to the solenoid, manually opening the main valve. Disengaging the Solenoid Manual operator returns the valve to the closed position.

*The wetted surface of this product contacted by consumable water contains less than 0.25% of lead by weight.

NOTICE

The information contained herein is not intended to replace the full product installation and safety information available or the experience of a trained product installer. You are required to thoroughly read all installation instructions and product safety information before beginning the installation of this product.

M Series Basic Valves

Pump Control Valve with Rate-of-Flow Feature

Full Port Ductile Iron Single Chamber Basic Valve

This Watts Automatic Control Valve (ACV) is a full port, single chamber basic valve that incorporates a one-piece disc and diaphragm assembly. This assembly is the only moving part within the valve allowing it to open, close, or modulate as commanded by the pilot control system.

Watts ACV Main Valves are Lead Free. The Watts ACV piloting system contains Lead Free* components, ensuring all of our configurations are Lead Free compliant.

Globe Pattern Single Chamber Basic Valve (M100)
 Angle Pattern Single Chamber Basic Valve (M1100)

Standard Materials

- Body and Cover: Ductile Iron ASTM A536
- Coating: NSF Listed Fusion Bonded Epoxy Lined and Coated
- Trim: 316 Stainless Steel
- Elastomers: Buna-N (standard)
 EPDM (optional)
 Viton™ (optional)
- Nut, Spring and Stem: Stainless Steel
- Anti-Scale (Optional): Xylan Coated Stem and Seat



Viton™ is a trademark of The Chemours Company FC, LLC

Operating Pressure

- Threaded = 400psi (27.6 bar)
- 150# Flanged = 250psi (17.2 bar)
- 300# Flanged = 400psi (27.6 bar)
- Grooved End = 400psi (27.6 bar)

Operating Temperature

- Buna-N: 160°F (71°C) Maximum
- EPDM: 300°F (140°C) Maximum
- Viton™: 250°F (121°C) Maximum
- Epoxy Coating**: 225°F (107°C) Maximum

** Valves can be provided without internal epoxy coating consult factory

Basic Valve Body Options



Globe Flanged



Angle Flanged



Globe Grooved End



Angle Grooved End



Globe Threaded



Angle Threaded

ACV Schematic - Series LFM113-41

Flow Data

Valve Size - Inches		1/4	1/2	2	2 1/2	3	4	6	8	10	12	14	16
Suggested	Maximum Continuous Flow Rate Gpm (Water)	95	130	210	300	485	800	1850	3100	5000	7000	8500	11100
	Maximum Intermittent Flow Rate Gpm (Water)	119	161	265	390	590	1000	2300	4000	6250	8900	10800	14100
	Minimum Flow Rate Gpm (Water)	3	5	6	9	15	16	17	25	55	70	190	400
Cv	Cv Factor GPM (Globe)	26	26	48	75	112	188	387	764	1215	1734	2234	3131
	Cv Factor GPM (Angle)	26	27	57	91	125	207	571	889	1530	1945		

- Maximum continuous flow based on velocity of 20 ft. per second.
- Maximum intermittent flow based on velocity of 25 ft. per second.
- Minimum flow rates based on a 20-40 psi pressure drop.
- The C_v Factor of a valve is the flow rate in US GPM at 60°F that will cause a 1psi drop in pressure.
- C_v factor can be used in the following equations to determine Flow (Q) and Pressure Drop (ΔP):

$$Q \text{ (Flow)} = C_v \sqrt{\Delta P} \quad \Delta P \text{ (Pressure Drop)} = (Q/C_v)^2$$

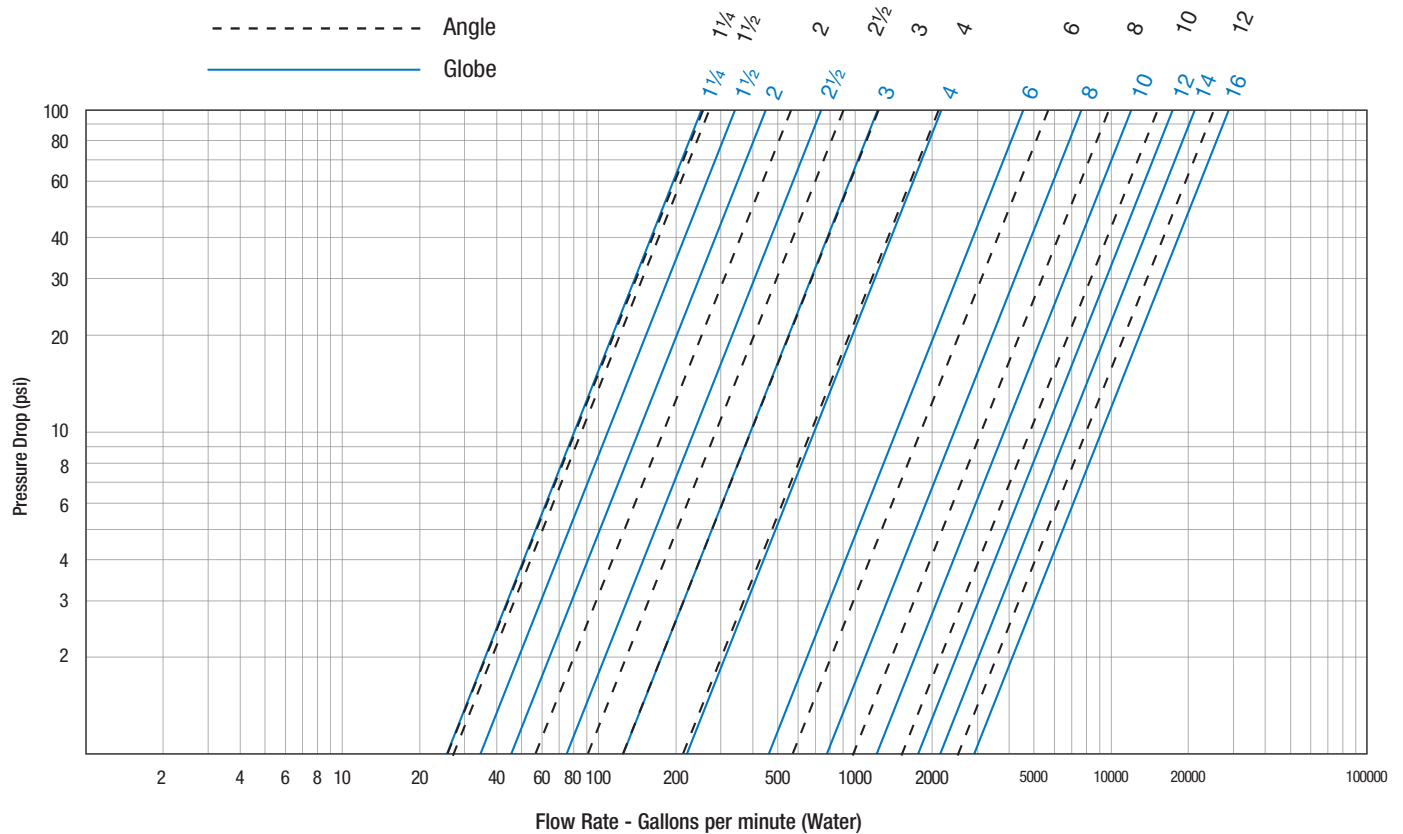

Valve Cover Chamber Capacity

Valve Size - Inches	1/4	1/2	2	2 1/2	3	4	6	8	10	12	14	16
fl.oz.	4	4	4	10	16	22	70					
U.S. Gal								1/4	2 1/2	4	6 1/2	9 1/2

Valve Travel

Valve Size - Inches	1/4	1/2	2	2 1/2	3	4	6	8	10	12	14	16
Travel - Inches	3/8	3/8	1/2	5/8	3/4	1	1 1/2	2	2 1/2	3	3 1/2	4

ACV Schematic - Series LFM113-41

Basic Valve

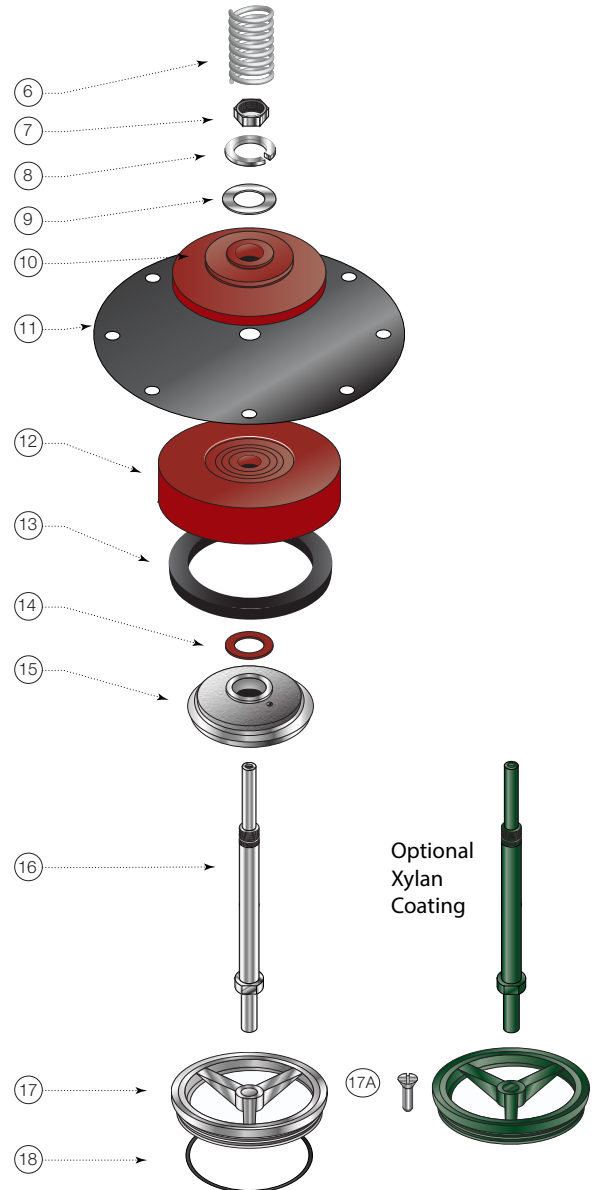
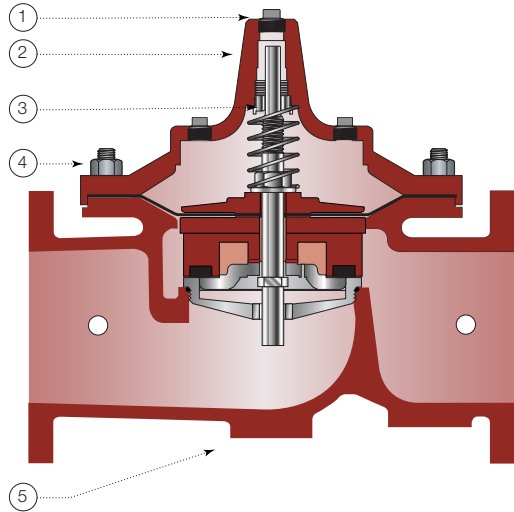

Item	Description	Material
1	Pipe Plug	Lead Free Brass
2	Cover	ASTM A536 65-45-12 Epoxy Coated Ductile Iron
3	Cover Bearing	ASTM A276 304 Stainless Steel
4	Stud with Cover Nut and Washer	ASTM A570 Gr.33 Zinc Plated Steel
5	Body	ASTM A536 65-45-12 Epoxy Coated Ductile Iron
6	Spring	ASTM A276 302 Stainless Steel
7	Stem Nut	ASTM A276 304 Stainless Steel
8	Lock Washer	ASTM A276 304 Stainless Steel
9	Stem Washer	ASTM A276 304 Stainless Steel
10	Diaphragm Washer	ASTM A536 65-45-12 Epoxy Coated Ductile Iron
11	Diaphragm*	Buna-N (Nitrile)
12	Disc Retainer	ASTM A536 65-45-12 Epoxy Coated Ductile Iron
13	Seat Disc*	Buna-N (Nitrile)
14	Spacer Washer* x5	NY300 Fiber*
15	Disc Guide	ASTM A743 CF8M (316) Stainless Steel
16	Shaft	ASTM A276 304 Stainless Steel
17	Seat Ring**	ASTM A743 CF8M (316) Stainless Steel
17A	Seat Screw** (8" and Larger)	ASTM A276 304 Stainless Steel
18	Seat Gasket*	Buna-N (Nitrile)

* Contained in Main Valve Repair Kit

**Note: 6 inch and Smaller Valves, Seat Ring is threaded

NOTICE

Installation: If unit is installed in any orientation other than horizontal (cover up) OR extreme space constraints exist, consult customer service prior to or at the time of order.

ACV Schematic - Series LFM113-41

Dimensions

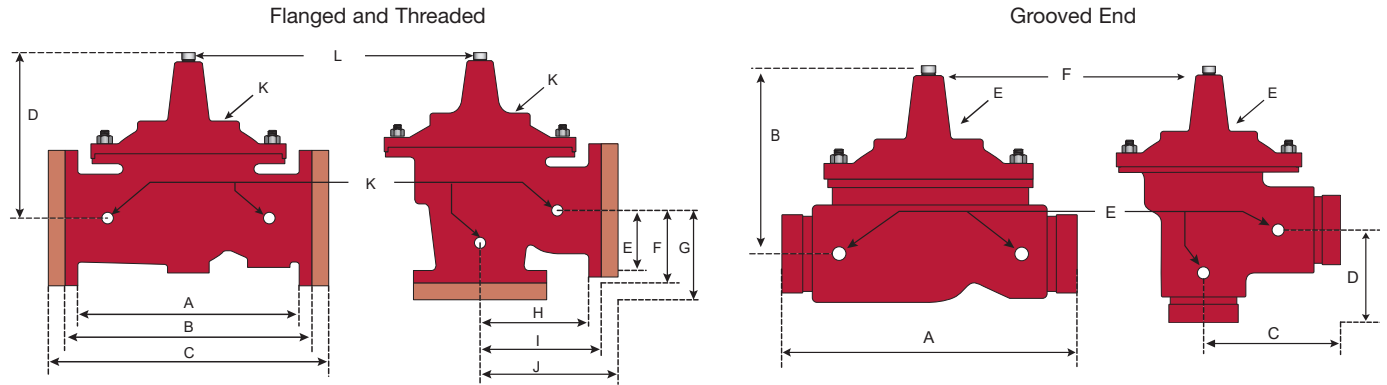

Flanged and Threaded Dimensions

Valve Size	Globe Thread		Globe 150#		Globe 300#		Cover To Center		Angle Thread		Angle 150#		Angle 300#		Angle Thread		Angle 150#		Angle 300#		Port Size NPT	Port Size NPT	Shipping Weights*	
	A	B	C	D	E	F	G	H	I	J	K	L												
in.	in.	mm	in.	mm	in.	mm	in.	mm	in.	mm	in.	mm	in.	mm	in.	mm	in.	mm	in.	mm	in.	in.	lbs.	kgs.
1¼	7¼	184					5½	140													¾	¼	20	9
1½	7¼	184	8½	216			5½	140	¾	83					1⅞	48					¾	¼	25	11
2	9⅞	238	9⅞	238	10	254	6¾	171	4¼	120	4¼	121	5	127	¾	83	¾	83	¾	89	¾	½	40	18
2½	11	279	11	279	11⅞	295	7½	191	5½	140	5½	140	5⅞	149	4	102	4	102	4⅞	110	½	½	65	29
3	12½	318	12	305	13¼	337	8¼	210	6¼	159	6	152	6⅞	162	4½	114	4	102	4⅞	111	½	½	95	43
4			15	381	15⅞	397	10⅞	270			7½	191	7⅞	200			5	127	5⅞	135	¾	¾	190	86
6			20	508	21	533	13	330			10	254	10½	267			6	152	6½	165	¾	¾	320	145
8			25⅞	645	26⅞	670	16	406			12¾	324	13¼	337			8	203	8½	216	1	1	650	295
10			29¾	756	31⅞	791	17	430			14⅞	378	15⅞	395			8⅞	219	9⅞	237	1	1	940	426
12			34	864	35½	902	20⅞	530			17	432	17¾	451			13¾	349	14½	368	1	1¼	1500	680
14			39	991	40½	1029	24¼	616													1	1½	1675	760
16			41⅞	1051	43½	1105	25¼	640													1	2	3100	1406

Grooved End Dimensions

Valve Size	Globe Grooved		Cover To Center		Angle Grooved		Angle Grooved		Port Size (npt)	Port Size (npt)	Shipping Weights*	
	A	B	C	D	E	F					lbs.	kgs.
in.	in.	mm	in.	mm	in.	mm	in.	mm	in.	in.		
1¼	8½	216	5½	140	4¼	108	¾	83	¾	¼	25	11
1½	8½	216	5½	140	4¼	108	¾	83	¾	¼	25	11
2	9	229	6½	165	4¾	121	¾	83	¾	½	40	18
2½	11	279	7½	191	5½	140	4	102	½	½	65	29
3	12½	318	8¼	210	6	152	4¼	108	½	½	95	43
4	15	381	10⅞	270	7½	191	5	127	¾	¾	190	86
6	20	508	13⅞	340					¾	¾	320	145
8	25⅞	645	16	406					1	1	650	295

LEAD FREE*

Model 22

3-Way Accelerator Control

Size: 1/2"

The Model 22 3-Way Accelerator Pilot is a diaphragm actuated control with three separate ports: Supply, Common and Exhaust. It is normally installed in the pilot control circuit of an Automatic Control Valve, with the supply port connected to upstream pressure, the common port connected to the Main Valve cover chamber, and the exhaust port vented either downstream or to atmosphere. Its large 1/2" ports offer increased capacity, and allow smaller ported devices, such as a 3-Way Solenoid, Float or Altitude Pilot, to operate the Main Valve open and closed.

When the cover of the Accelerator Pilot is de-pressurized, the main valve cover chamber is connected to upstream pressure, causing the valve to close drip tight.

When the cover of the Accelerator Pilot is pressurized, the main valve cover chamber is vented downstream (dry drain) or to atmosphere (wet drain), causing the valve to open.

The Model 22 is designed with an integral orifice to provide a constant source of pressure for valve regulation, when modulating features are desired in addition to normal On/Off operation.



Model LF22

Specifications

- Size: 1/2"
- Body Material: C87800 Silicone Bronze (std)
CF8M Stainless Steel (opt)
- Elastomers: Buna-N (std)
Viton™ (opt)
EPDM (opt)
- Inlet Pressure Rating: 400 psi maximum

Viton™ is a trademark of The Chemours Company FC, LLC

*The wetted surface of this product contacted by consumable water contains less than 0.25% of lead by weight.

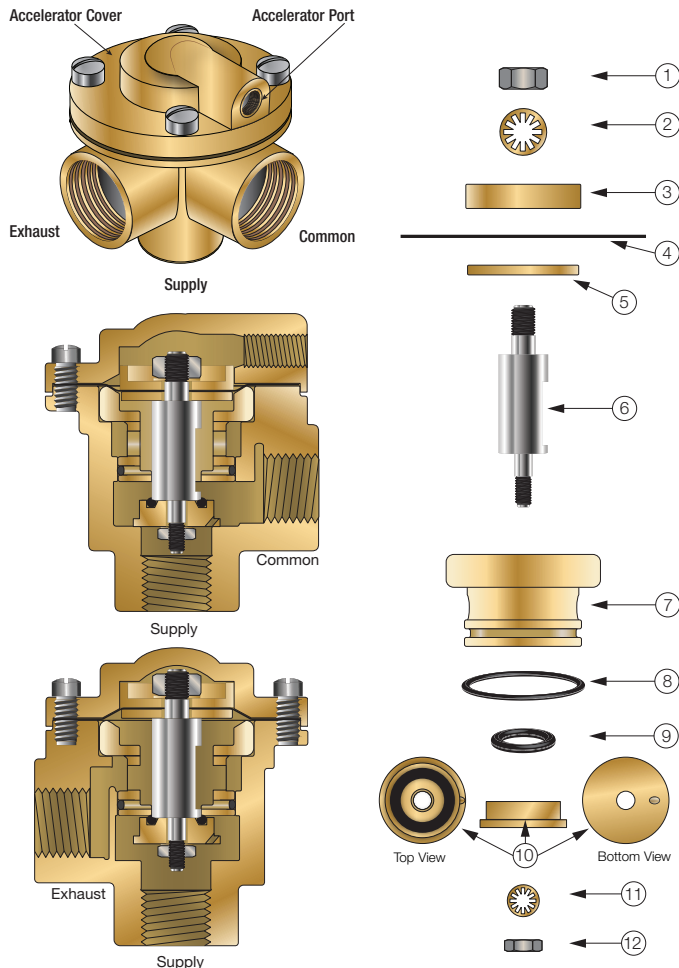

Parts List

Item	Description
1	Nut
2	Lock Washer
3	Upper Diaphragm
4	Diaphragm*
5	Lower Diaphragm Washer
6	Stem
7	Spool
8	O-Ring*
9	O-Ring*
10	Retainer
11	Lock Washer
12	Nut

*Included in Repair Kit

LEAD FREE*

Model 51 Single Limit Switch

The Model 51 Single Limit Switch provides visual indication of valve position, as well as remote electrical indication of "valve open" or "valve closed". The single pole double throw Micro-Switch can be connected to open or close an electrical circuit when the valve opens or closes.

The adjustable collar is normally set to contact the trip arm when the main valve is closed. The collar can be positioned on the stem by loosening the set-screw to actuate the switch at the desired point of valve travel.

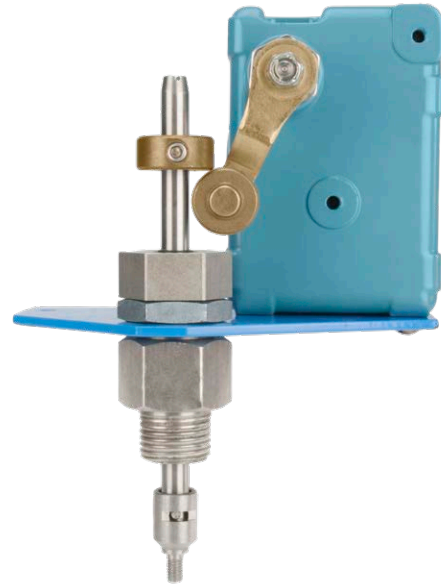

Model LF51

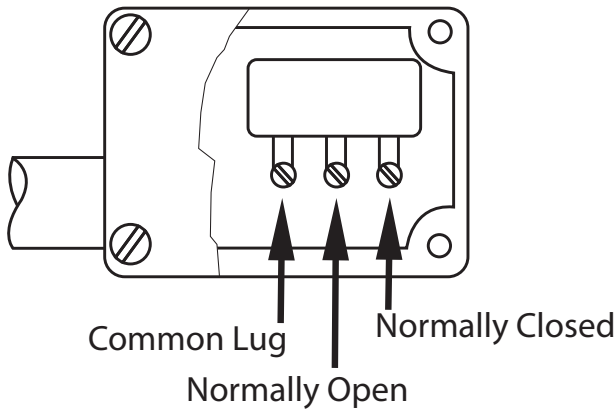

Single Pole Double Throw Switch

Specifications

- Body Material: Stainless Steel
- Elastomers: Buna-N (standard)
EPDM (optional)
Viton™ (optional)
- Enclosure: NEMA 1, 3, 4 and 13 General Purpose (standard)
NEMA 1, 7 and 9 Explosion Proof (optional)
- Electrical: Form C SPDT Switch
15 amp. 125, 250 or 480 VAC
½ amp. 125 VDC
¼ amp. 250 VDC
½" Conduit Connection

Viton™ is a trademark of The Chemours Company FC, LLC

*The wetted surface of this product contacted by consumable water contains less than 0.25% of lead by weight.

Parts List

Item	Description
1	Limit Switch
2	Bracket
3	Stem
4	Trip collar
5	Set Screw
6	Cap
7	Wiper Ring*
8	O-Ring*
9	Guide
10	O-Ring*
11	Polypak*
12	Locknut
13	Body
14	Pin
15	Coupling

*Included in Repair Kit

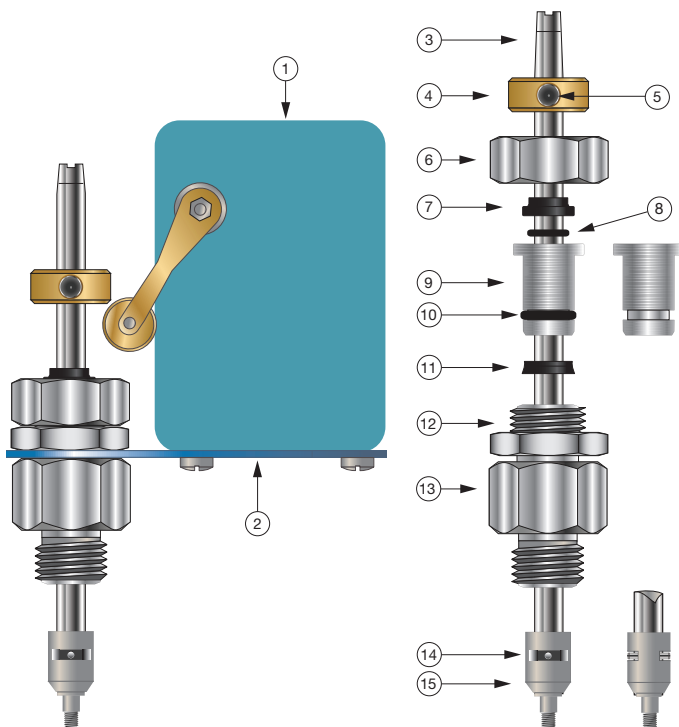

Model S3W

3-Way Solenoid

Size: 1/8" – 1/2" NPT

Model S3W are pilot system 3-way solenoids. The solenoids can control valves independently or in combination with other control circuit pilots or accessories. Product is available with a wide range of options including: voltage (24VDC, 24VAC or 120VAC), operation (energize to open or closed) and a range of enclosures (general service to watertight to explosion proof).



Model S3W
Brass



Model S3W
Stainless Steel

Manual Operator

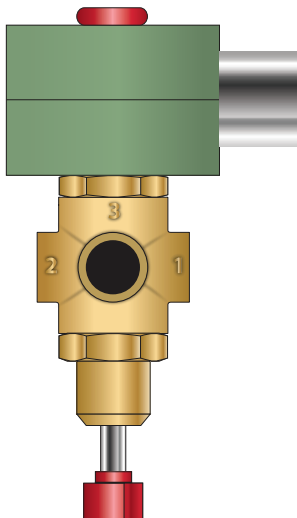

Normal Operating Condition

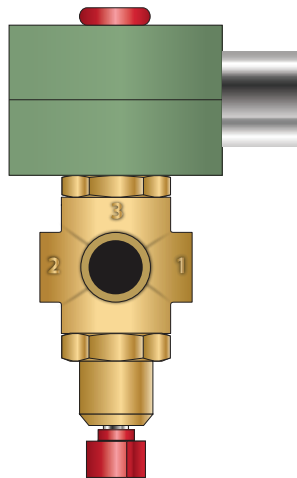

Manual Override

Specifications

- Body Material:** Brass (standard)^{***}
Stainless Steel (optional)
- Elastomers:** Nitrile (standard)
EPDM (optional)
Viton™ (optional)
- Voltage:** 24VDC, 24VAC or 120VAC
- Enclosure:** General Purpose – NEMA 4 (standard)
Explosion Proof – NEMA 6, 6P, 7, 9 (optional)
- Action:** Normally Open or Normally Closed^{**}

^{**}Solenoid Action only. Main valve action (energize-to-open or energize-to-close) is dependent on the particulars of the pilot system.

^{***}Brass solenoids are not lead free and it is illegal to use them in potable services in the United States such as drinking water, handwashing, food preparation, and dishwashing. However, brass solenoids may be used as a replacement component in a lead free Watts ACV main valve, as the wetted surface of a lead free Watts ACV main valve including installed brass solenoids contains less than 0.25% of lead by weight.

Viton™ is a trademark of The Chemours Company FC, LLC

^{*}The wetted surface of this product contacted by consumable water contains less than 0.25% of lead by weight.

LEAD FREE*

Model CK

Check Valve

Size: 1/4" – 1" NPT

Model CK Check Valves are pilot line check valves. In typical applications these low cracking pressure in-line checks provide a hydraulic check feature to a pilot system. When the main valve outlet pressure exceeds inlet pressure, fluid is directed from the outlet to the main valve cover. This causes the main valve to close until inlet pressure is again greater than outlet.



Model LFCCK

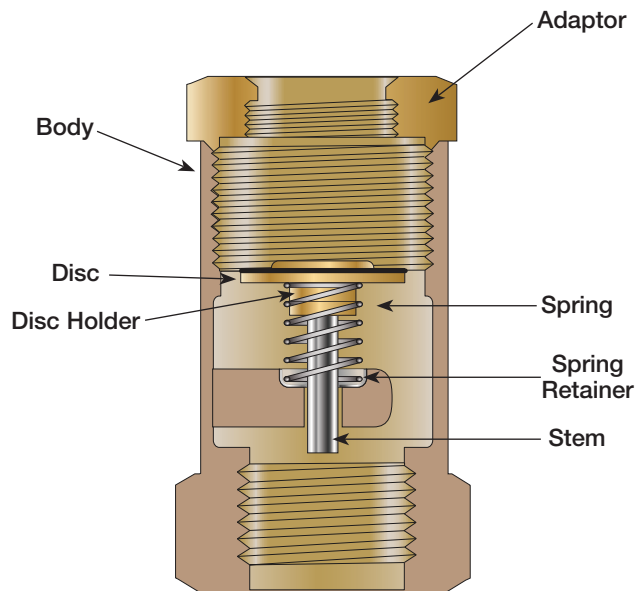

Specifications

Standard Material: Brass Housing and Body
Stainless Steel Indicating Rod

Optional Material: Stainless Steel Housing and Body Disc
Viton™ (1/4" – 1/2")
PTFE (1")

Pressure Rating: 400psi (27.6 bar)

Viton™ is a trademark of The Chemours Company FC, LLC

*The wetted surface of this product contacted by consumable water contains less than 0.25% of lead by weight.

LEAD FREE*

Model LFFC

Flow Control

Size: Standard Flow - 1/2" MNPT x 3/8" FNPT
 High Flow - 1/2" MxF NPT

A Flow Control is an adjustable device used for tuning valve performance. It can be installed to either control the opening or closing the speed of the automatic control main valve. When the flow is in the direction of the needle the flow control is an adjustable restriction. In the free flow direction the seat moves out of the flow path to all unrestricted flow.

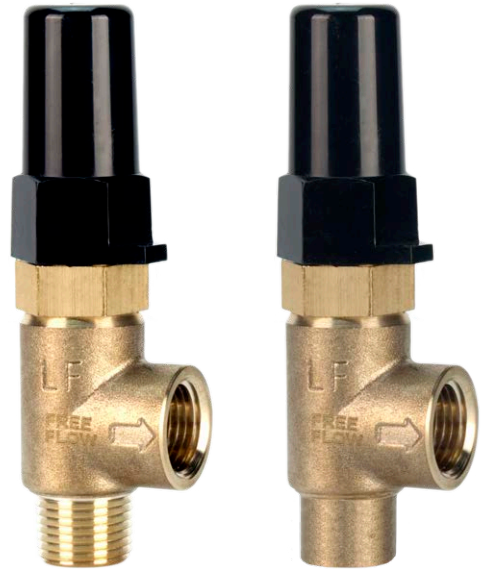

Large Flow Control

Standard Flow Control

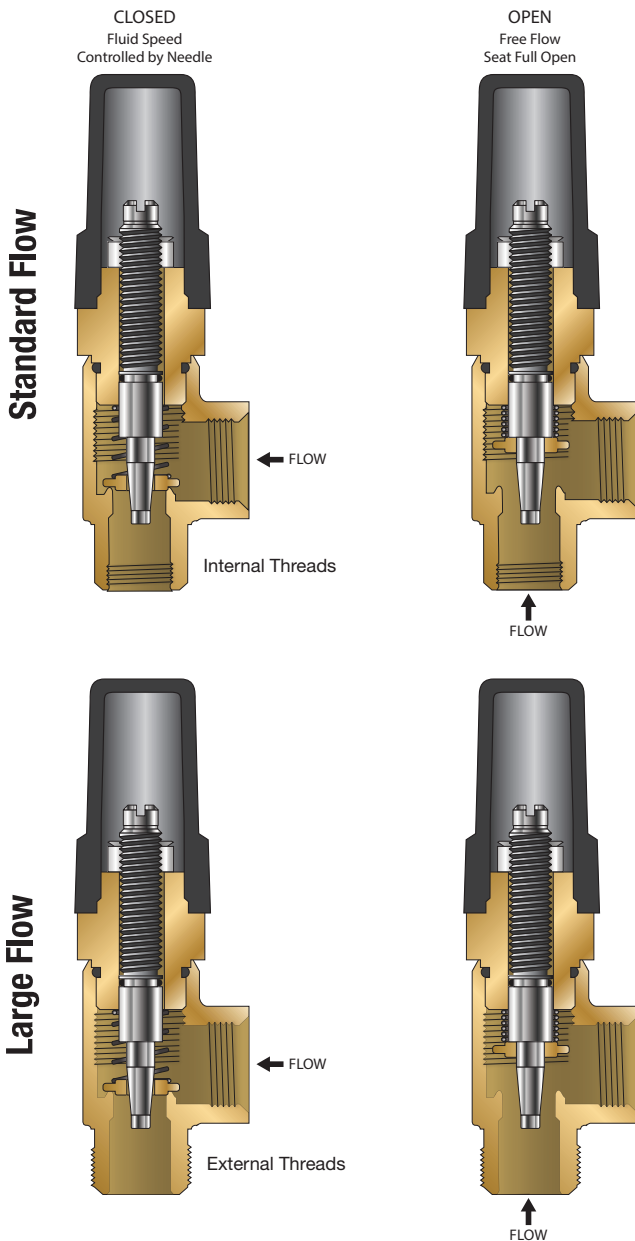

Specifications

- Size: Standard Flow - 1/2" MNPT x 3/8" FNPT
 High Flow - 1/2" MxF NPT
- Body Material: Lead Free Brass
 Stainless Steel (optional)
- Seat: Lead Free Brass
- Needle: Stainless Steel (304)
- Elastomers: Buna-N (standard)

*The wetted surface of this product contacted by consumable water contains less than 0.25% of lead by weight.

LEAD FREE*

Model LFCP14-1

Rate-of-Flow Pilot

Size: 3/8" NPT

The Model LFCP14-1 is a direct acting, diaphragm actuated Pilot that senses and responds to changes in a differential pressure signal. The differential pressure signal is usually created by an orifice plate located inline either upstream or downstream of the Main Valve. The Pilot has two sensing chambers, one above and one below the diaphragm. The "low" pressure signal is sensed above the diaphragm, and the "high" pressure signal is sensed below the diaphragm.

An increase in flow rate causes the differential pressure across the orifice plate to increase. The Pilot modulates toward a closed position when the differential pressure signal increases above the control setpoint, causing the Main Valve to modulate toward a closed position, decreasing flow rate.

A decrease in flow rate causes the differential pressure across the orifice plate to decrease. The Pilot modulates toward an open position when the differential pressure signal decreases below the control setpoint, causing the Main Valve to modulate toward an open position, increasing flow rate. Turning the adjustment screw clockwise raises the control setpoint, increasing flow rate. Turning the adjustment screw counterclockwise lowers the control setpoint, decreasing flow rate.

The LFCP14-1 is equipped with one 3/8" NPT inlet and two outlet ports for ease of installation, and two 1/8" NPT sensing ports. The 1/8" sensing port above the diaphragm is used to monitor the "low pressure" differential signal, and the sensing port below the diaphragm is used to monitor the "high pressure" differential signal.



LFCP14-1

Specifications

Body Material:	Lead Free Copper Silicon Alloy CF8M (316) Stainless Steel (Optional)
Seat:	316 Stainless Steel
Elastomers:	Buna-N (standard) Viton™ (optional) EPDM (optional)
Inlet Pressure Rating:	400psi (27.6 bar) maximum

Viton™ is a trademark of The Chemours Company FC, LLC

*The wetted surface of this product contacted by consumable water contains less than 0.25% of lead by weight.

Model LFCP14-1

Rate-of-Flow Pilot

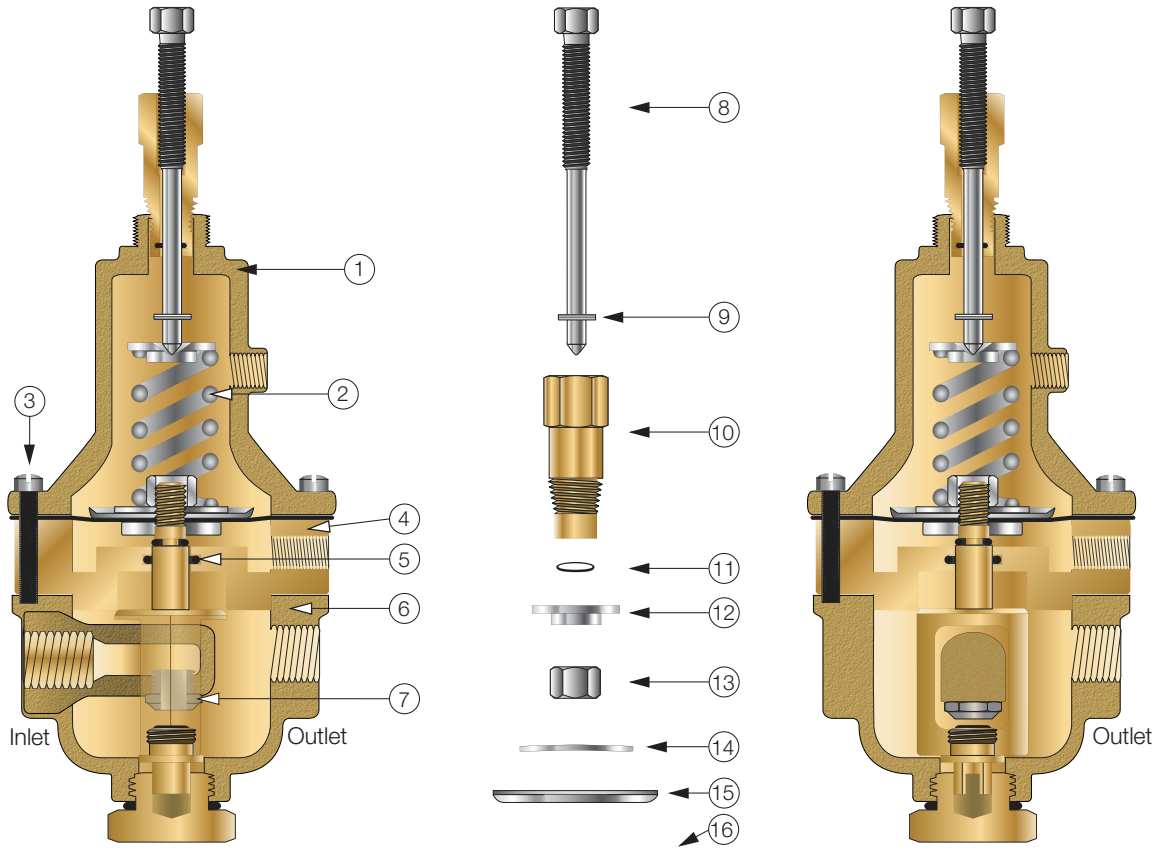

Item	Description
1	Spring Housing
2	Spring
3	Cap Screw
4	Power Chamber
5	O-Ring*
6	Body
7	Seat

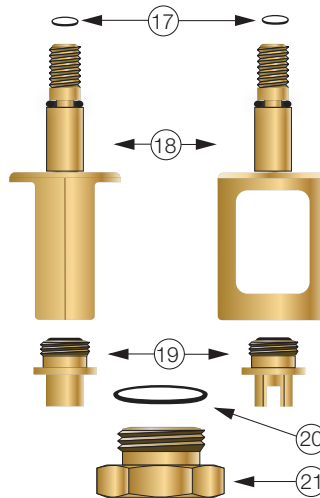

Item	Description
12	Spring Guide
13	Nut
14	Belleville Washer
15	Diaphragm Washer
16	Diaphragm *
17	O-Ring *
18	Yoke
19	Disc & Retainer Assembly*
20	O-Ring *
21	Bottom Cap

*Included in Repair Kit

LEAD FREE*

Model LF60-1

Y-Pattern Strainer

Size: ¼" – ¾" NPT

Model LF60-1 Y-Pattern Strainers are used to filter the fluid passing through the pilot circuit, and provide protection to pilot circuit speed controls and pilots. The filter element can be accessed for cleaning by removing the clean-out cap, or may be cleaned by installing an optional "blow-down" ball valve.



Model LF60-1

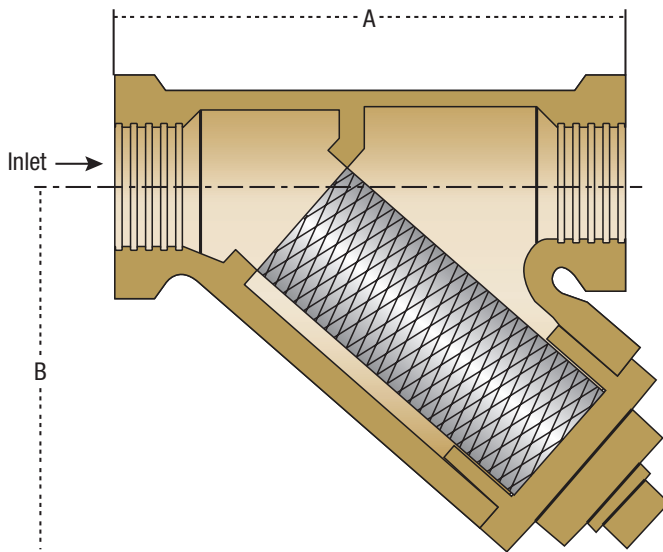

Specifications

Body Material:	Lead Free Copper Silicon Alloy CF8M (316) Stainless Steel (optional)
Retainer Cap:	Lead Free Copper Silicon Alloy
Cap Gasket:	EPDM
Pressure Rating:	400psi (27.6 bar)
Filter Element:	304 Stainless Steel
Mesh Options:	60 Mesh (standard) 100 Mesh (optional)

*The wetted surface of this product contacted by consumable water contains less than 0.25% of lead by weight.

Dimensions

SIZE	DIMENSIONS				WEIGHT	
	A		B		lbs.	kgs.
in.	in	mm	in	mm		
¼	2 ¹¹ / ₁₆	68	1 ¹¹ / ₁₆	43	1.7	0.77
⅜	2 ¹¹ / ₁₆	68	1 ¹¹ / ₁₆	43	1.7	0.77
½	3	76	2	51	1.7	0.77
¾	3 ⁵ / ₁₆	84	2 ⁵ / ₁₆	59	1.7	0.77

LEAD FREE*

Model BV

Ball Valve

Size: ¼" – 1" NPT

Model BV Ball Valves are used in pilot lines to provide a positive shutoff in any override or maintenance situation for simple trouble shooting. This 2-piece, full port valve features: bottom loaded stems, PTFE seats and packing.

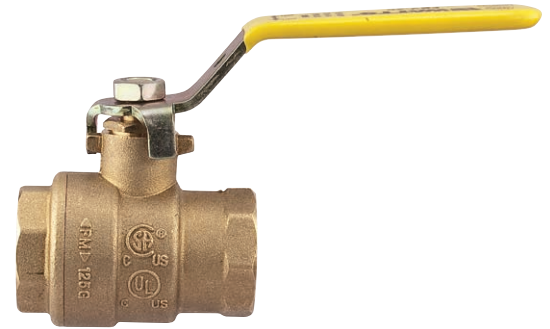

Lead Free Ball Valve

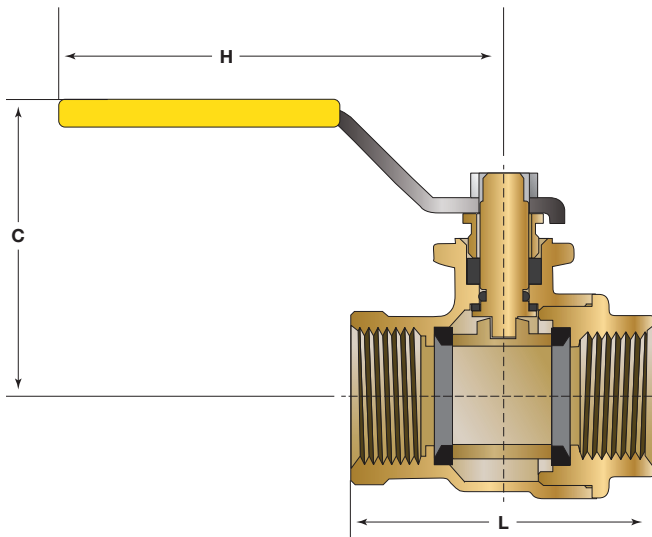

Specifications

- Standard Material: Copper Silicon Alloy Body and Adaptor
Chrome Plated Ball
- Optional Material: Stainless Steel Housing, Body and Adaptor
Stainless Steel Ball
- Pressure Rating: 600psi (41 bar) Non Shock
- Temp Rating: -40°F - 400°F

*The wetted surface of this product contacted by consumable water contains less than 0.25% of lead by weight.

Size	Dimensions						Weight	
	C		H		L		lbs.	kg.
in.	in.	mm	in.	mm	in.	mm		
¼	1 13/16	46	3 7/16	87	1 3/4	45	0.4	0.2
3/8	1 13/16	46	3 7/16	87	1 3/4	45	0.4	0.2
½	1 13/16	46	3 7/16	87	1 15/16	50	0.4	0.2
¾	2 ¼	57	4	101	2 5/16	59	0.8	0.3

LEAD FREE*

Model LF60

Flo-Clean Strainer

Size: 1/4" - 3/4" NPT

Model LF60 Flo-Clean Strainers are used to filter the fluid passing through the pilot circuit, and provide protection to pilot circuit speed controls and pilots. It is installed in the inlet body port of the Main Valve, exposing the strainer element to main line flow. The currents and flow across the screen create a self-scouring effect, cleaning the filter element.

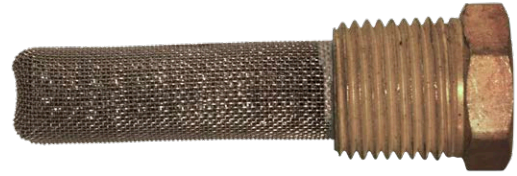

Model LF60

Valve inlet with Filter installed

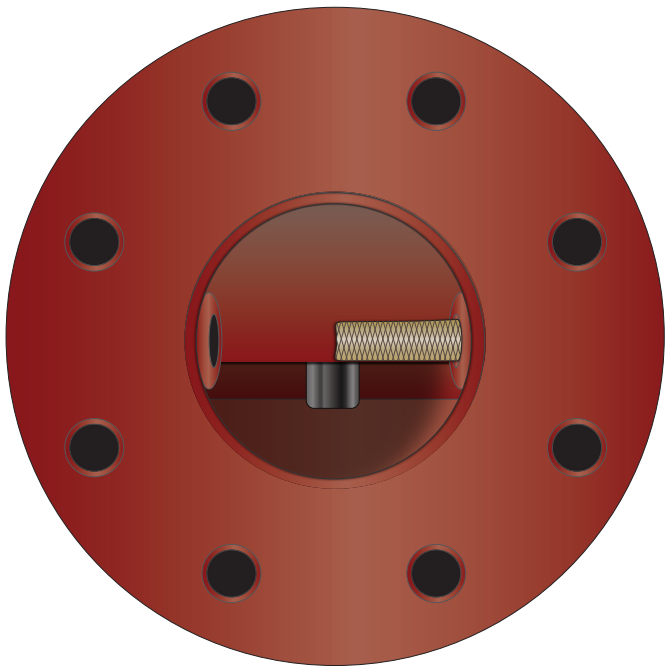

Specifications

Body Material:	Lead Free Brass (standard) Stainless Steel (optional)
Pressure Rating:	400psi (27.6 bar)
Filter Element:	Monel
Screen Mesh:	40 Mesh (standard)

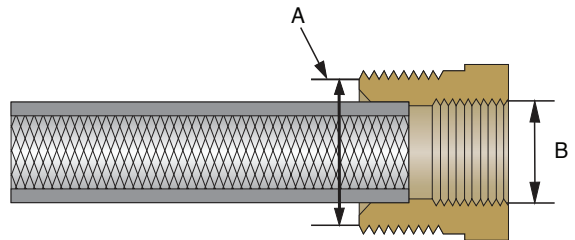

A	B
Male Pipe Thread	Female Pipe Thread
in.	in.
1/4	1/8
3/8	1/4
1/2	3/8

*The wetted surface of this product contacted by consumable water contains less than 0.25% of lead by weight.

LEAD FREE*

Model 51-1

Dual Limit Switch

Size: 2" - 8" NPT

The Model 51-1 Dual Limit Switch provides visual indication of valve position, as well as remote electrical indication of "valve open" and "valve closed". The single pole double throw Micro-Switches can be connected to open or close an electrical circuit when the valve opens or closes.

The adjustable collars are normally set to contact the trip arms to indicate "valve open" and "valve closed". The collars can be positioned on the stem by loosening the set-screws to actuate the switches at the desired point of valve travel.

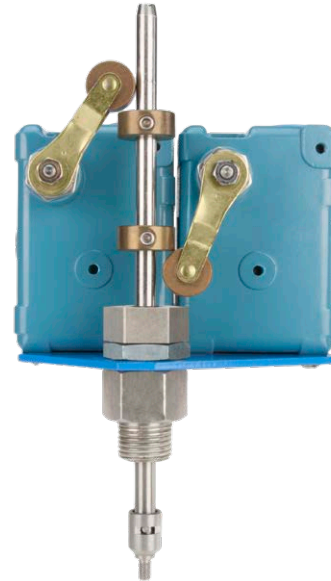

Model LF51-1

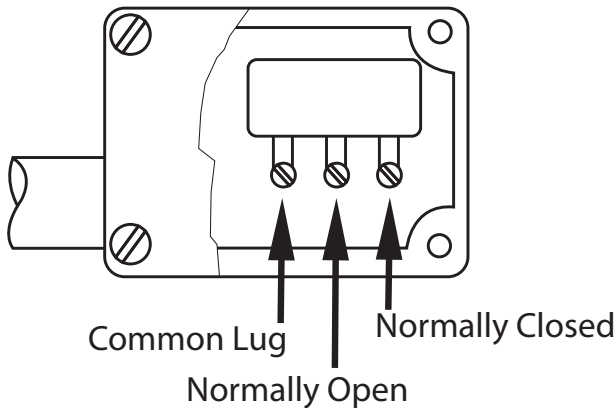

Single Pole Double Throw Switch

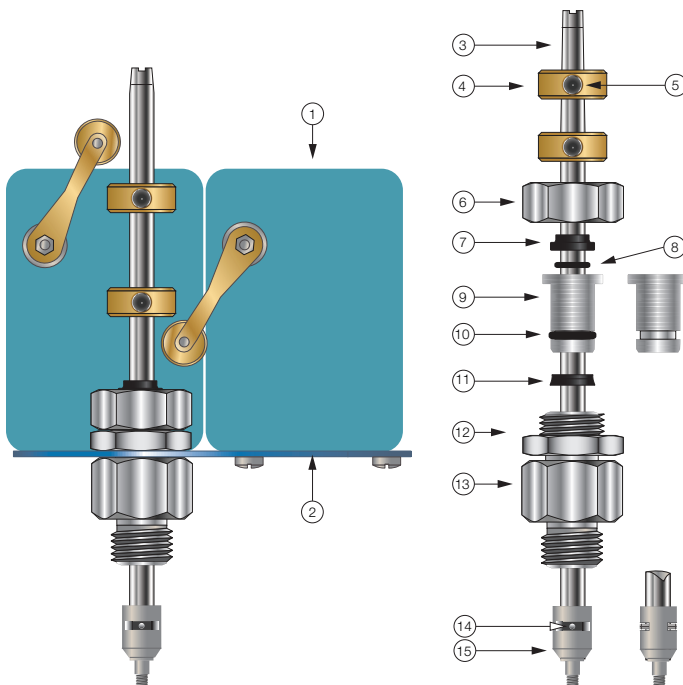

Specifications

- Body Material: Stainless Steel
- Elastomers: Buna-N (standard)
EPDM (optional)
Viton™ (optional)
- Enclosure: NEMA 1, 3, 4 and 13 General Purpose (standard)
NEMA 1,7 and 9 Explosion Proof (optional)
- Electrical: Form C SPDT Switch
15 amp. 125, 250 or 480 VAC
½ amp. 125 VDC
¼ amp. 250 VDC
½" Conduit Connection

Viton™ is a trademark of The Chemours Company FC, LLC

*The wetted surface of this product contacted by consumable water contains less than 0.25% of lead by weight.

Parts List

Item	Description
1	Limit Switch
2	Bracket
3	Stem
4	Trip collar
5	Set Screw
6	Cap
7	Wiper Ring*
8	O-Ring*
9	Guide
10	O-Ring*
11	Polypak*
12	Locknut
13	Body
14	Pin
15	Coupling

*Included in Repair Kit

Installation

Start-up of an automatic control valve requires that proper procedures be followed. Time must be allowed for the valve to react to adjustments and the system to stabilize. The objective is to bring the valve into service in a controlled manner to protect the system from damaging over-pressure.

1. Prior to installation, flush line to remove debris.
2. Install valve so the flow arrow matches flow through the line, and gauges to monitor valve inlet and outlet pressures. A Position Indicator can be installed to provide visual indication of valve position and operation without disassembly.
3. Install isolation valves upstream and downstream of the main valve.
4. Provide adequate clearance for valve servicing and maintenance. Refer to valve servicing dimensions on next page. Avoid installing valves 6" and larger in the vertical position (main valve stem horizontal). Automatic Control Valves (ACVs) are designed for horizontal in-line installation, with the cover facing up (main valve stem vertical). Slow operation or premature stem and guide wear may occur if valve is not installed according to factory recommendations. Consult factory for detailed engineering review prior to ordering if valve is to be installed other than horizontally in-line.
5. If valve is equipped with a pilot control system, extra precautions should be made during installation to protect the piping circuit from damage. Only remove the pilot control system from the valve if necessary. Tubing and fittings should be kept clean and replaced exactly as removed. Consult appropriate hydraulic schematic to ensure proper re-assembly.
6. Connect solenoid wiring leads to desired switching device, using safe, standard electrical practices.
7. Wire the limit switch contacts to the proper relay connections, using safe, standard electrical practices. Adjust the limit switch collar to the approximate make/break contact position.
8. After installation, vent entrapped air from valve cover and pilot system by following instructions in the **Commissioning the Pump Control Valve** section.
9. Field install downstream orifice plate assembly pressure sense lines per schematic.
 - To accurately set flow rates, either a differential gauge or a flow meter should be installed.
 - Check orifice plate to assure that sense holes are free from obstruction.

Valve Servicing Dimensions

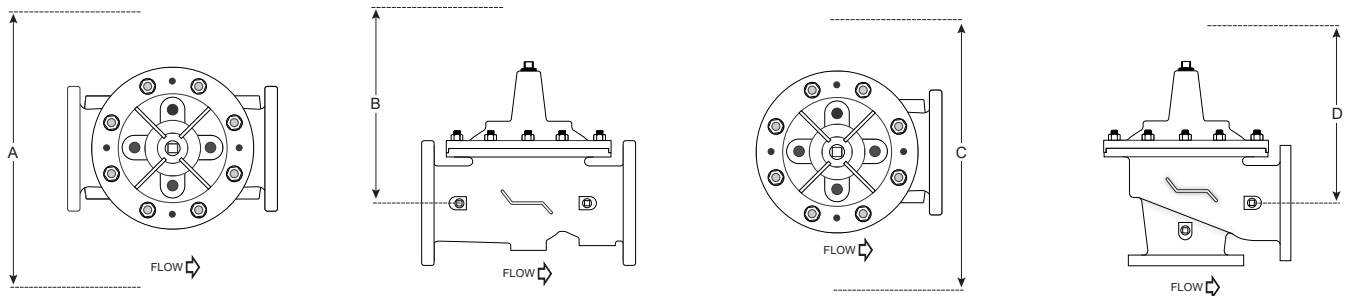

The following tables detail the recommended minimum valve servicing dimensions.

Globe

Size (in)	1¼	1½	2	2½	3	4	6	8	10	12	14	16	20	24
A (in)	16	16	20	22	22	24	32	34	38	44	48	52	56	56
B (in)	10	10	12	14	14	16	24	26	28	30	34	40	48	48

Angle

Size (in)	1¼	1½	2	2½	3	4	6	8	10	12	14	16
C (in)	16	16	20	22	22	24	32	34	38	44	48	52
D (in)	10	10	12	14	14	16	24	26	28	30	34	40

Commissioning the Pump Control Valve

STEP 1

Pre-set pilots as noted:

Rate of Flow – Adjust OUT, counterclockwise, to start valve at a lower flow rate.

Opening and Closing Speed – Turn the adjustment screws on the Closing Speed and Opening Speed Controls, if the main valve is so equipped, OUT, counterclockwise, 1½ to 2½ turns from full closed position.

3-Way Solenoid – Confirm that the manual operator is turn counter clockwise to a full OUT position (See Figure 1).

STEP 2

Loosen a tube fitting or cover plug at the main valve to allow air to vent during start-up.

STEP 3

Energize the solenoid to check actuation and to confirm connection to power source.

STEP 4

De-energize the solenoid prior to initial pump start.

STEP 5

Energize the solenoid at pump start to open the main valve, checking that the main valve opens. Air is vented through the loosened fitting. Tighten the fitting when liquid begins to vent.

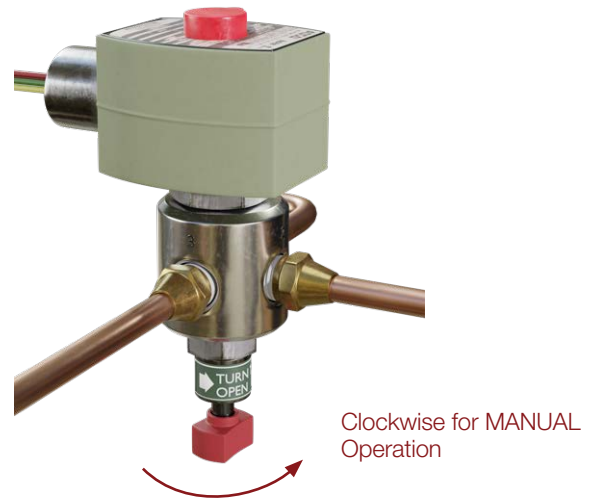

Figure 1
3-Way Solenoid

Setting the Rate-of-Flow Control

STEP 6

Slowly open downstream isolation valve to establish flow through the system.

STEP 7

With a demand for flow on the system, the valve can now be adjusted for the proper flow rate. This requires a meter to read the flow that the valve is providing.

STEP 8

While reading the meter register, adjust the Rate of Flow Control:

Turn the adjustment screw IN, clockwise, to increase the flow rate regulated (See Figure 2A).

Turn the adjustment screw OUT, counterclockwise, to reduce or lower the flow rate regulated (See Figure 2B).

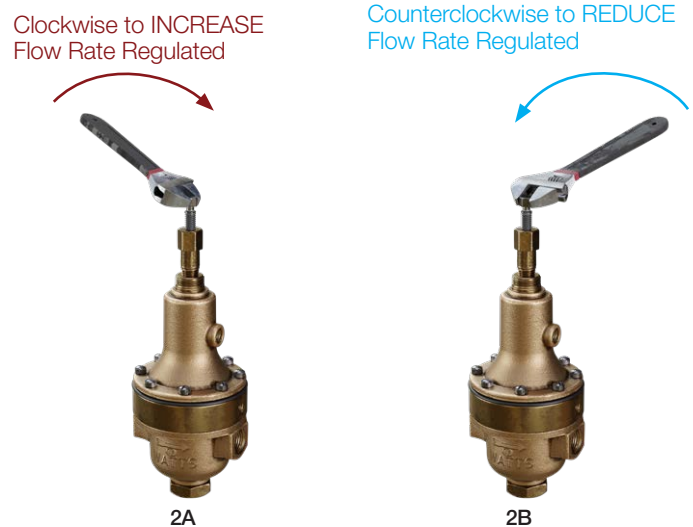

Figure 2
CP14-1 Rate-of-Flow Control Pilot

Installation, Operation and Maintenance - Series LFM113-41

STEP 9

Opening Speed Flow Control Adjustment: The Opening speed flow control allows free flow into the cover and restricted flow out of the cover of the main valve.

If valve opening is too slow, turn the adjustment screw OUT, counterclockwise, increasing the rate of opening (See Figure 3B).

If valve opening is too quick, turn the adjustment screw IN, clockwise, decreasing the rate of opening (See Figure 3A).

Clockwise to DECREASE
rate of opening

Counterclockwise to INCREASE
the rate of opening

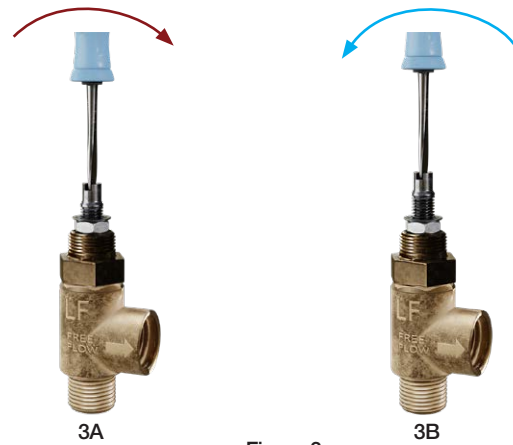

Figure 3
Flow Control

STEP 10

De-energize the solenoid to check that the main valve closes.

STEP 11

Closing Speed Needle Valve Adjustment: The closing speed needle valve regulates fluid pressure into the main valve cover chamber, controlling the valve closing speed.

If valve closing is too slow, turn the adjustment screw OUT, counterclockwise, increasing the rate of closing.

STEP 12

At valve closure booster pump will stop. Adjust limit switch collar to final position to ensure positive actuation of limit switch electrical contact, if necessary, by sliding up/down to location (See Figure 4).

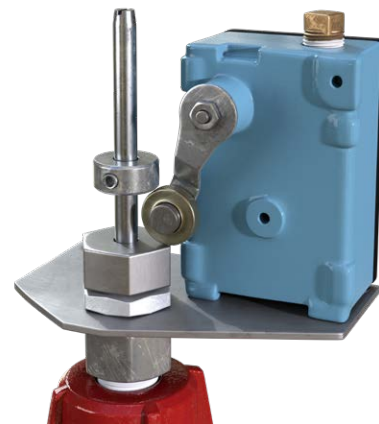

Figure 4
Limit Switch in Closed Position

Automatic Control Valve Maintenance Schedule

To ensure peak performance and longevity of your automatic control valve, Watts/Ames recommends following the below standard maintenance schedule.

• Monthly Maintenance

- Visual inspection of valve(s) for leaks
- Inspect for proper operation(s); exercise valve.

• Quarterly Maintenance

- Conduct monthly inspection.
- Validate/Re-establish necessary setpoints of controls/pilots.

• Annual Maintenance

- Conduct monthly & quarterly inspections.
- Inspect & clean all strainers.
- Inspect valve coating, touch up as required.

• 3-5 Year Maintenance

- Conduct monthly, quarterly, & annual maintenance.
- Inspect & replace valve elastomers (diaphragm, O-rings, valve/pilot seats)
- Re-establish necessary set points of controls/pilots.

Troubleshooting Guide

⚠ WARNING

Warning: The valve cannot be serviced under pressure. Upstream and downstream Isolation Valves must be installed to protect system piping. Accurate diagnosis and troubleshooting requires the valve to open fully, and may subject downstream piping and equipment to high pressure and/or flow rates. The downstream Isolation Valve should be kept closed while diagnosing the valve.

Extreme caution should be used while performing the troubleshooting techniques listed below.

Recommended tools for diagnosis: (3) PRESSURE GAUGES, installed to monitor the inlet pressure, outlet pressure, and cover chamber pressure. If included, a POSITION INDICATOR should be installed to visually assess the position of the disc & diaphragm assembly.

Test 1: Diaphragm Seal Test

1. Close upstream & downstream isolation valves. Close pilot isolation valves or remove pilot control tubing to isolate valve cover from incoming fluid & pressure. Remove uppermost cover plug, test cock, or limit switch.
2. With the valve cover chamber vented to atmosphere, partially open the upstream isolation valve, allowing incoming pressure to lift the disc & diaphragm assembly. A volume of water will be displaced from the cover chamber as the valve opens; consult valve specification sheets for approximate cover capacity. A continuous flow of water from the open port indicates a damaged diaphragm or loose disc & diaphragm assembly. Disassemble valve and replace diaphragm or tighten disc & diaphragm assembly.

Test 2: Seat Seal Test

1. Close downstream isolation valve and install pressure gauges on an open inlet and outlet port of main valve.
2. Open upstream isolation valve to allow pressure on to the valve cover. Allow valve to fully close.
3. Monitor downstream pressure gauge; reading should hold steady below incoming pressure. If pressure on downstream side rises to match upstream pressure, leakage is occurring through the seat of the main valve. Disassemble valve, inspect and repair/replace any required parts.
 - a. If gauge pressure rises to match outlet pressure (downstream of closed isolation valve) yet remains below inlet pressure, the isolation valve may be leaking as opposed to main valve seat.

Test 3: Freedom of Movement/Valve Travel Test

1. Close upstream and downstream isolation valves. Install valve position indicator.
2. Partially open upstream isolation valve and allow cover to fill with fluid & pressure, closing the valve fully. Mark the position indicator's full closed position.
3. Isolate cover chamber from receiving fluid and pressure by closing isolation valves or removing control tubing.
4. Carefully vent cover chamber to atmosphere by opening test cock or removing a cover plug. Observe the valve position indicator as the valve travels to the full-open position. The disc & diaphragm assembly should move freely from fully closed to fully open position without binding or "grabbing" at any point during its movement.
 - a. The disc & diaphragm assembly may momentarily "hesitate" while travelling from fully closed to fully open position – this is a normal characteristic of diaphragm operated control valves, and does not indicate mechanical binding or improper valve operation.
 - b. A continuous discharge of water from the cover chamber after venting to atmosphere indicates leakage past the diaphragm.
5. If necessary, disassemble valve and inspect/repair disc & diaphragm assembly.

Troubleshooting Guide

Issue	Possible Cause	Corrective Action	Notes
Main Valve will not open	Closed isolation valves in pilot system.	Check isolation valves, ensure open.	
	Insufficient supply pressure.	Check upstream pressure.	Depending on water source, supply pressure may not be controlled by valve operator.
	Main valve stem assembly corroded/damaged	Inspect stem assembly, clean/replace if necessary.	
	Blockage in pilot system.	Inspect & clean any installed pilot system strainers, check orifice/speed controls for blockages.	
	Improperly configured opening speed control.	Adjust opening speed control to verify functionality, adjust as required.	Standard setting for opening speed control is 1½ - 2½ turns open from full closed position. Can be adjusted in field.
Main Valve will not close	Closed isolation valves in pilot system	Check isolation valves, ensure open.	
	Diaphragm is damaged	Conduct diaphragm seal test, repair and replace if necessary.	
	Main valve stem assembly corroded/damaged.	Inspect stem assembly, clean/replace if necessary.	
	Blockage in main valve.	Perform freedom of movement test; if valve does not close, disassemble and remove blockage.	
	Worn/damaged valve seat.	Perform seat sealing check; disassemble and inspect/repair seat if required.	
	Improperly configured closing speed control.	Adjust closing speed control to verify functionality, adjust as required.	Standard setting for closing speed control is 1½ - 2½ turns open from full closed position. Can be adjusted in field.
Solenoid will not actuate	Possible Cause: Low or no voltage	Check voltage at the solenoid connection, insuring that it has the minimum of 85% of the coils rated voltage.	Should be performed by licensed electrician
	Manual operated is engaged	Turn manual operator counter-clockwise to disengage	

Valve Disassembly Instructions

Before undertaking valve disassembly, it is recommended to gather the following tools to aid you during the process:

- Small & large adjustable wrenches
- Screwdriver set
- Machinist fine metal file
- Fine wire brush
- Bench vise
- Basic valve IO&M manual
- Hammer & dull cold chisel
- Heavy-duty ratchet & socket set
- Hexagonal wrench set
- 320 grit/fine Emery cloth
- Appropriate technical bulletins for valve start-up procedures.

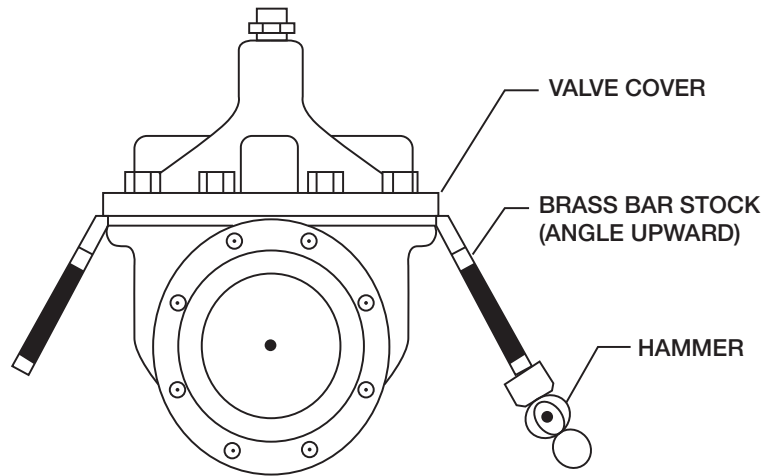

1. Isolate the valve from line pressure and depressurize it to ensure safe working conditions. Disconnect any electrical connections if so equipped.
2. Carefully remove Position Indicator or Limit Switches if equipped. Remove all tubing, fittings, and Control Pilots necessary to easily access and remove the cover. Remove cover nuts and washers.
3. Remove the cover. If cover is not free to be removed, loosen it by tapping upward along its outside edge with a dull cold chisel, pictured above.
 - a. Large valves may require the installation of lifting “eye” bolts in order to facilitate cover removal; installation ports are provided on the cover for this purpose.
4. Remove the Disc and Diaphragm Assembly from the valve body by lifting straight up.
 - a. Large diameter valves may require a lifting “eye” bolt to be installed in the valve stem accessory threads located on the very top of the valve stem.
5. Before removing Stem Nut, examine stem threads for mineral build-up. Remove deposits with a fine wire brush. Extreme care should be taken not to damage the finish on stem guiding surfaces when disassembling. Avoid applying pipe wrenches to top or bottom stem guide surfaces.
6. After removing the Stem Nut, the remainder of the Disc & Diaphragm Assembly should disassemble easily. Polish stem guide surfaces with fine emery cloth to remove any mineral deposits and inspect for excessive wear. Remove any mineral build-up from other components with wire brush or by using a Mineral Dissolving Solution. Inspect parts for wear and replace if necessary.
7. Inspect valve seat. If seat is not damaged, removal is not necessary. Valve seats 6" and smaller are threaded into the body of the valve and require a seat removal tool (Figure 5) (Table 1 details the tool dimensions for seat removal). Valve seats 8" and larger are held in the valve body with stainless steel cap screws. Remove seat retaining screws and lift seat straight up (Figure 6).

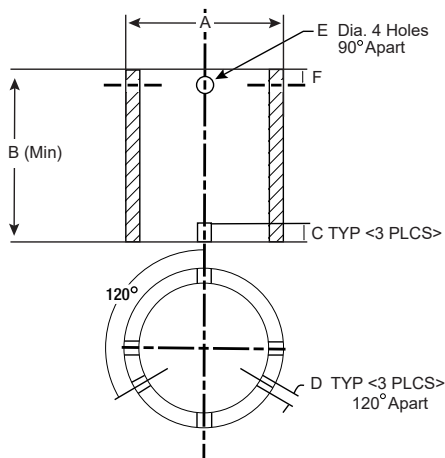

Figure 5

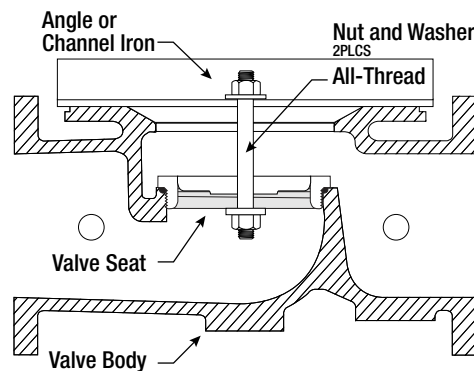

Figure 6

Installation, Operation and Maintenance - Series LFM113-41

Table 1: Seat Removal Tool Dimension

Size	A	B	C	D	E (Dia.)	F
<i>in</i>	<i>Pipe Size (in)</i>	<i>Min. Length (in)</i>	<i>in</i>	<i>in</i>	<i>in</i>	<i>in</i>
1¼	1	3.12	0.38	0.25	0.44	0.55
1½	1	3.12	0.38	0.25	0.44	0.50
2	1¼	3.38	0.38	0.25	0.44	0.50
2½	2	4.0	0.38	0.38	0.56	0.62
3	2½	4.5	0.50	0.38	0.56	0.62
4	3	5.0	0.50	0.44	0.56	0.62
6	5	6.50	0.62	0.44	0.56	0.62

*Schedule 40 steel pipe

- Replace Seat Disc, Diaphragm and Spacer Washers provided in Main Valve repair kit (refer to Table 2 or 3 for correct repair kit part number). Re-assemble in the reverse order of disassembly.

Table 2: Full Port Valve (M100/M1100) Repair Kits

Size (in)	1¼	1½	2	2½	3	4	6	8	10	12	14	16
P/N	0677-01	0677-01	0677-02	0677-03	0677-04	0677-05	0677-06	0677-07	0677-08	0677-09	0677-10	0677-11

Table 3: Reduced Port Valve (M6100 / M61100) Repair Kits

Size (in)	3	4	6	8	10	12	16	20 & 24
P/N	0677-02	0677-04	0677-05	0677-06	0677-07	0677-08	0677-09	0677-11

- Re-Install Disc and Diaphragm Assembly in the valve, taking care not to damage the lower guide area in the center of the valve seat.
- Re-install Cover Spring. Replace Valve Cover and tighten Cover Nuts in a crossing pattern to ensure even distribution. Test the Disc and Diaphragm Assembly for smooth travel by following the Freedom of Movement Test procedure in previous section.
- Test the integrity of the Seat Seal by following the Seat Seal Test procedure in previous section.
- Return valve to service by following instructions in the **Commissioning the Pump Control Valve** section matching the valve function.

Limited Warranty: Watts Regulator Co. (the "Company") warrants each product to be free from defects in material and workmanship under normal usage for a period of one year from the date of original shipment. In the event of such defects within the warranty period, the Company will, at its option, replace or recondition the product without charge.

THE WARRANTY SET FORTH HEREIN IS GIVEN EXPRESSLY AND IS THE ONLY WARRANTY GIVEN BY THE COMPANY WITH RESPECT TO THE PRODUCT. THE COMPANY MAKES NO OTHER WARRANTIES, EXPRESS OR IMPLIED. THE COMPANY HEREBY SPECIFICALLY DISCLAIMS ALL OTHER WARRANTIES, EXPRESS OR IMPLIED, INCLUDING BUT NOT LIMITED TO THE IMPLIED WARRANTIES OF MERCHANTABILITY AND FITNESS FOR A PARTICULAR PURPOSE.

The remedy described in the first paragraph of this warranty shall constitute the sole and exclusive remedy for breach of warranty, and the Company shall not be responsible for any incidental, special or consequential damages, including without limitation, lost profits or the cost of repairing or replacing other property which is damaged if this product does not work properly, other costs resulting from labor charges, delays, vandalism, negligence, fouling caused by foreign material, damage from adverse water conditions, chemical, or any other circumstances over which the Company has no control. This warranty shall be invalidated by any abuse, misuse, misapplication, improper installation or improper maintenance or alteration of the product.

Some States do not allow limitations on how long an implied warranty lasts, and some States do not allow the exclusion or limitation of incidental or consequential damages. Therefore the above limitations may not apply to you. This Limited Warranty gives you specific legal rights, and you may have other rights that vary from State to State. You should consult applicable state laws to determine your rights. **SO FAR AS IS CONSISTENT WITH APPLICABLE STATE LAW, ANY IMPLIED WARRANTIES THAT MAY NOT BE DISCLAIMED, INCLUDING THE IMPLIED WARRANTIES OF MERCHANTABILITY AND FITNESS FOR A PARTICULAR PURPOSE, ARE LIMITED IN DURATION TO ONE YEAR FROM THE DATE OF ORIGINAL SHIPMENT.**



USA: T: (978) 689-6066 • F: (978) 975-8350 • Watts.com
Canada: T: (888) 208-8927 • F: (905) 481-2316 • Watts.ca
Latin America: T: (52) 55-4122-0138 • Watts.com