



Zoning Solutions

Thermostats & Zone Controls
Designed to Maximize Indoor Comfort



Zoning in on Comfort & Energy Savings



Through zoning, the perfect temperature is customized for each area.

Traditionally, heating, ventilating & air conditioning systems supplied one temperature to the entire building, leaving some areas too cold or too hot.

Today, systems provide customized temperatures to different areas of a building through the use of multiple thermostats.

Comfort At Your Command

Radiant floor heating & cooling systems have differing control requirements to forced air systems. tekmar thermostats & controls are designed to maximize the performance of both, keeping each room at the perfect temperature.

- *Program when & where you want heating or cooling*
- *Make adjustments to the temperature in each room*
- *Control the floor & air temperature*





Choose Your Level of Control

Choose from 3 different product lines to suit your application needs. Classic, Performance & Designer series products offer distinct features & benefits to perfectly match your existing system or design requirements.

Classic Series



Stand-alone thermostats control an on/off heating zone to gain energy savings & indoor comfort. Add Wiring Centers for simplified wiring & troubleshooting, as well as powered outputs to zone pumps or valves. A compact enclosure makes Wiring Centers ideal for remote manifold wiring, resulting in cleaner installations with less wiring back to the mechanical room.

Performance Series



Use tekmarNet® communication between thermostats to optimize energy savings, equipment reliability & comfort. Communicating thermostats use Zone Synchronization to coordinate heat calls & reduce equipment cycling, as well as share outdoor temperature information, scheduling & programs.

Designer Series



Access more features to support greater functionality for integration of air & hydronic applications. tekmarNet® zone managers & expansion modules offer flexibility to add more zones & feature a built-in fused transformer, a large enclosure for easy wiring & the convenience of a zone group pump output. Designed for simplicity & energy savings, thermostats use touchscreen technology & tekmarNet® communication.

Classic Series

Stand Alone Heating and/or Cooling

Our thermostats are engineered for the heating characteristics of radiant systems to reliably provide an even space temperature. Wiring Centers simplify wiring between the thermostat & zone valves or zone pumps. They include diagnostic LED's for each zone & an endswitch to start an external device such as a boiler.



- Simplified Wiring
- External Zone Indicator Lights

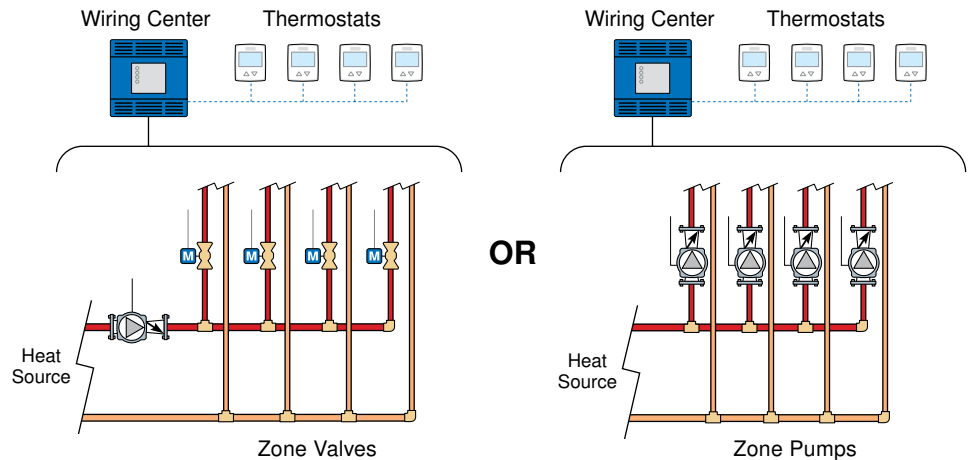

Performance Series

Multi-Zone or Hydronic & Air Systems

tekmarNet[®] communication between thermostats allows for advanced energy saving strategies. Zone Synchronization reduces boiler cycling while interlocked heating & cooling streamlines control of air & hydronic systems. Communication provides a shared outdoor temperature & options for quick system overrides, internet access or integration with home automation systems.



- tekmarNet[®] Communication
- Zone Synchronization
- Shared Outdoor Air Temperature
- Single Stage Heat / Cool with Interlock

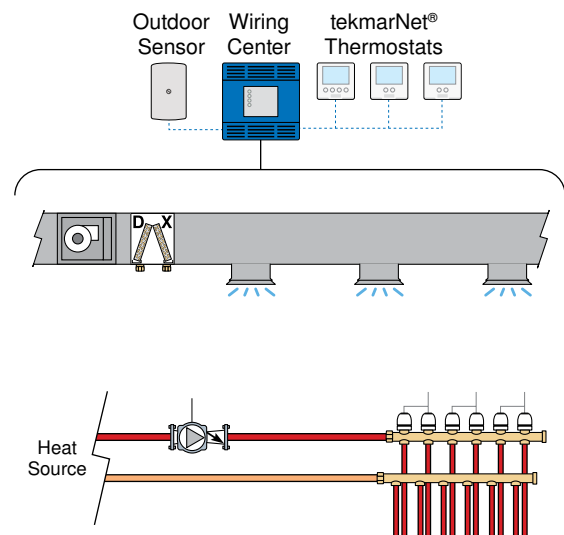

Save Energy & Increase Comfort With tekmarNet® Communication

Two-way communication allows for increased energy savings, a reduction in boiler cycling & steadier air temperatures. When tekmarNet® thermostats & system controls are used together, further performance improvements are made with features like Outdoor Temperature Reset with Indoor Temperature Feedback. The ability to remotely connect using a home automation system or internet browser is an additional benefit of tekmarNet® communication.



Boost Boiler Efficiency with Zone Synchronization

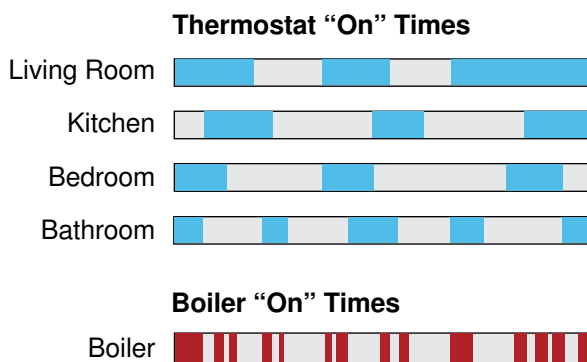

Without synchronization, the boiler is at the mercy of each zone. Non-communicating thermostats short cycle the boiler to achieve independent targets rather than system-wide goals. Boiler operation is inefficient & unreliable.

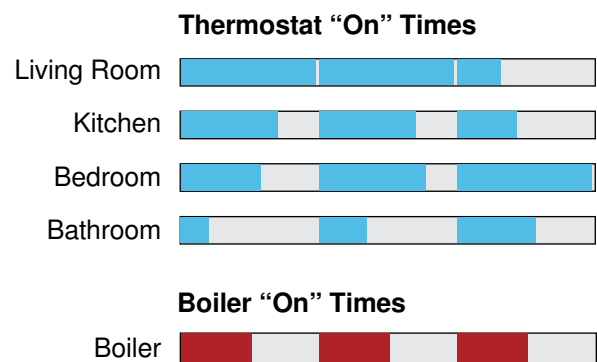

With synchronization, the cycle start times are coordinated between zones to allow for longer on & off times. Reducing equipment short cycling prolongs the boiler life & improves system efficiency.

Zone Synchronization is a feature of the Performance & Designer series.



Designer Series

Multi-Zone or Multi-Stage Hydronic & Air Systems

Designer series thermostats have more stages of ventilation, heating & cooling, as well as more auxiliary sensor options. Offering the most flexibility, this product series supports more complex applications, including radiant floor cooling & humidity control. Designer series thermostats are commonly used with tekmarNet® Wiring Centers, Zone Managers, Modules & System Controls to further optimize comfort & efficiency. Through tekmarNet® communication, these thermostats can share schedules, system overrides & provide a heating / cooling interlock.



- Touchscreen Technology
- Relative Humidity Control
- Flexibility in Mechanical Design
- tekmarNet® Communication
- Zone Synchronization
- Shared Outdoor Air Temperature
- Multi-stage Heating & Cooling
- Heat / Cool Interlock
- Large Wiring Chambers

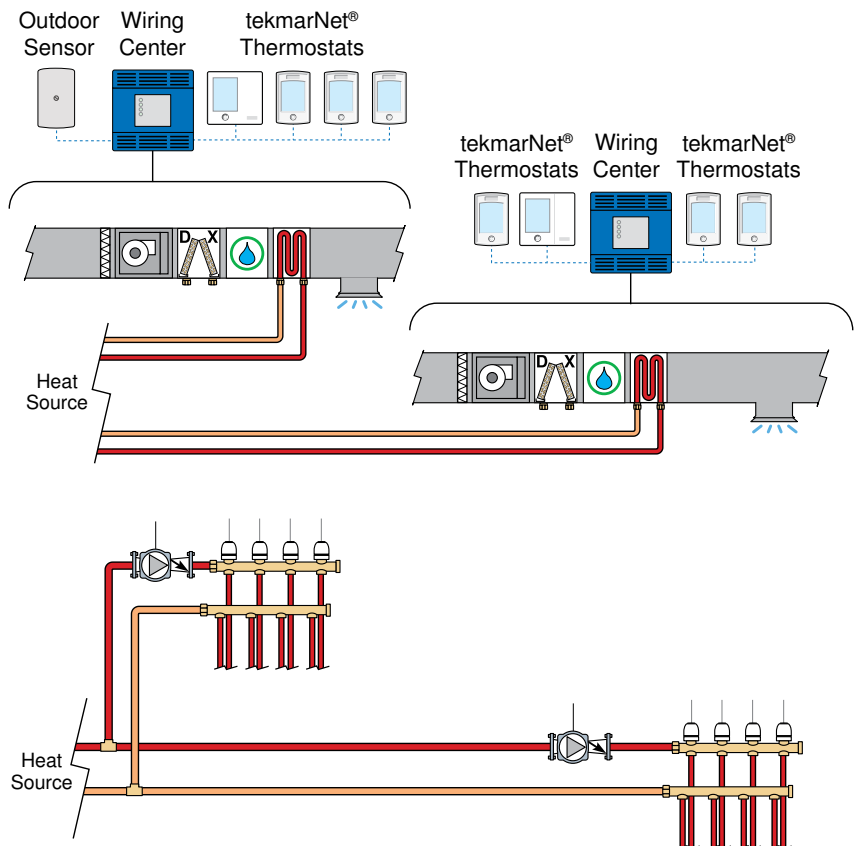

Improve System Efficiency, Reliability & Comfort

To get the best system performance, combine tekmarNet® communicating thermostats with an HVAC System Control. Thermostats provide Indoor Temperature Feedback to the control, which automatically fine tunes the boiler water temperature & coordinates the heating & cooling equipment to maximize comfort.

For more information refer to our website or the HVAC System Solutions guide.

www.tekmarControls.com



The tekmarNet® Thermostat 557 Offers Relative Humidity Control

The tekmarNet® Thermostat 557 is a communicating touchscreen thermostat designed to operate either a hydronic radiant floor with a two stage heat pump (water-to-air or air-to-air) for heating & cooling plus an emergency backup heating system, or two stages of heating & two stages of cooling.

There are three auxiliary sensor inputs that can be used to measure room, floor, outdoor or duct temperature. The optional floor sensor allows precise heating of radiant floors. Relative humidity level can be measured & controlled using either the built-in or external humidity sensor.

“ Introducing humidity control, bringing air & hydronic systems together. ”



- *Touchscreen Technology*
- *Radiant Floor Heating & Cooling*
- *Relative Humidity Control*
- *tekmarNet® Communication*
- *Programmable Schedules*
- *Optimum Start*
- *Away/Vacation Mode*
- *Remote System Access*
- *Home Automation Integration*

Compare Thermostats

Classic Series



System Requirements		518	519	521
Heat Stages 2 Stage Example: Radiant 1 st stage & fan coil 2 nd stage		1	1	2*
Cool Stages 2 Stage Example: Radiant cooling 1 st stage & dx coil 2 nd stage		-	-	1*
Heat Pump Stages For direct control of heat pump from thermostat		-	-	-
Fan/ERV/HRV Stages 2 Stage Example: Low speed fan 1 st stage with high speed 2 nd stage		-	-	1
Auxiliary Sensor Inputs Number of external sensor connections		1	1	2
Auxiliary Sensor Input Options Support a wider range of applications with these types of external sensors	Outdoor	•	•	•
	Room	•	•	•
	Floor	•	•	•
	Duct	-	-	-
	Coil	-	-	-
	Humidity	-	-	-
Humidity Control On-board humidity sensor		-	-	-
tekmarNet® Communication - 2 or 4 wire Number of conductors for power & communication in tekmarNet® system		-	-	-
Radiant Floor Heating Designed to operate for maximum comfort		•	•	•
Radiant Floor Cooling Combine radiant floor systems & heat pumps for cooling		-	-	-
Features & Benefits		518	519	521
Built-In Programmable Schedule Program savings without affecting comfort		-	-	•
Touchscreen Technology Large touchscreen makes programming easy		-	-	-
Remote Monitoring Access tekmarNet® systems via the internet with a Gateway 483		-	-	-
System Wide Control Add a User Switch to quickly override all networked thermostats		-	-	-
Zone Synchronization Coordinate heat demands, minimize equipment cycling		-	-	-
Air Group Master Prevent heating & cooling from running simultaneously & operate multiple heating zones within a single cooling zone		-	-	-
Air Group Member Participate in an 'Air Group' controlled by the 'Air Group Master'		-	-	-
Supports Network Scheduling Centralized scheduling for all thermostats		-	-	-
Integrate with Home Automation Systems Connect to home automation systems with a Gateway 482		-	-	-
Add a Wiring Center or Zone Manager Simple, quick installation & troubleshooting		•	•	-

* If 2 heat stages are used, then no cooling is available

** Requires tN2 Wiring Center or House Control

Performance Series

Designer Series



527	528	529	530	537	538	540	546	552	553	557
1	1	2	1	1	1	1	2	1	2	2
-	-	-	1	-	-	1	2	-	1	2
-	-	-	-	-	-	-	-	-	1	2
-	-	-	1	-	-	1	2	-	1	1
-	1	1	-	-	1	-	3	2	2	3
-	●	●	-	●	●	-	●	●	●	●
-	●	●	-	●	●	-	●	●	●	●
-	●	●	-	●	●	-	●	●	●	●
-	-	-	-	-	-	-	●	-	●	●
-	-	-	-	-	-	-	●	-	●	●
-	-	-	-	-	-	-	-	-	-	●
-	-	-	-	-	-	-	-	-	●	●
2**	2**	2**	2**	4	4	4	4	2 or 4	2 or 4	2 or 4
●	●	●	●	●	●	●	●	●	●	●
●	●	●	●	●	●	●	-	●	●	●
527	528	529	530	537	538	540	546	552	553	557
-	-	-	-	-	-	-	●	●	●	●
-	-	-	-	-	-	-	-	●	●	●
●	●	●	●	●	●	●	●	●	●	●
●	●	●	●	●	●	●	●	●	●	●
●	●	●	●	●	●	●	●	●	●	●
-	-	-	●	-	-	●	●	-	●	●
●	●	●	-	●	●	-	●	●	●	-
●	●	●	●	●	●	●	●	●	●	●
●	●	●	●	●	●	●	●	●	●	●
●	●	●	●	●	●	●	●	●	●	●

Compare Wiring Centers, Zone Managers & Expansion Modules

Performance Series



313 314 315 316

Features & Benefits

tekmarNet® Communication - 2 or 4 wire
Select number to match thermostats

2 2 4 4

Zone Control with Valves (V) or Pumps (P)
Includes number of onboard zone outputs

4 V 4 P 6 V 4P

Built-in End Switch
Enables an external device such as a boiler

• • • •

Zone Group Pump
Local 115 V (ac) pump output

1 - 1 -

Remote Manifold Wiring Center
Provides convenient wiring with 2 conductors to mechanical room

• • • •

Supports Classic Thermostats
Combine tekmar zone solutions with standard thermostats

- - • •

Built-In Transformer
Convenient internal transformer for 24 V (ac) output

- - - -

Accessibility Options for tekmarNet® Systems



tN4 User Switch 479

One simple touch lets you command all thermostats to occupied, unoccupied or away temperature settings. In some systems, the away temperature setting can also suspend domestic hot water generation to save additional energy.



tN4 Gateway 482

Conveniently access tekmarNet® thermostat settings through your home automation system. View & adjust room temperature settings with the same remote control, touch screen or software application that controls lighting, entertainment & security settings.

Designer Series



334	335	336	337	324	325	326
2	4	4	4	2	4	4
4 V or P	6 V	4 P	3 V+3 V	4 V or P	6 V	3 P
-	-	-	-	-	-	-
1	1	1	2	1	1	1
-	-	-	-	-	-	-
-	-	-	-	-	-	-
•	•	•	•	•	•	•



tN4 Gateway 483

Use a smart phone or computer to access heating & cooling settings from anywhere in the world. Conveniently set temperatures back while on vacation & bring systems out of energy saving mode before arriving home. Take advantage of the ability to monitor system information & temperature trends plus receive alerts & make control adjustments remotely.

“ Go Anywhere,
Get Connected ”

Better Design, Better Control, Better Systems.

At tekmar Control Systems, we believe the indoor comfort of a building depends on the performance of its heating, ventilating & air conditioning (HVAC) system. That's why tekmar offers affordable control solutions designed to produce the best in comfort, efficiency & system performance.

Our focus on innovation to add greater value to our products & services allows us to pioneer technologies & anticipate the needs of tomorrow. We stand by our products & offer in-depth technical support & training to ensure our customers are completely satisfied.

World Class Technical Support

Our local Representatives are knowledgeable experts in both HVAC controls & their operating mechanical systems. They offer assistance in system design, product selection & installation support. We're here when you need us most. To contact a Representative in your area, visit www.tekmarControls.com

Dependable Warranty

We strive to provide the highest quality products to our customers. In keeping with that goal, all of our products are 100% quality tested, & backed by the most dependable 3-year limited warranty in the industry.



We Offer the Complete Solution

- *A wide range of products to match the needs of today's systems*
- *Manufactured in a state-of-the-art Canadian facility*
- *A network of experienced & knowledgeable Representatives*
- *Training & technical tools available to support your success*
- *Dedicated staff focused on innovation & customer service*

For more information regarding tekmar products, visit www.tekmarControls.com

tekmar[®]

A **WATTS** Brand