

# Application Brochure

## WiFi Snow Melting Control 671



671\_A

08/19

Snow Melting Replaces: New

The WiFi Snow Melting Control 671 operates hydronic and electric heating equipment designed to melt snow and/or ice from roads and walkways surfaces. The control works with tekmar Snow/Ice Sensor 090 or Snow Sensor 095 to automatically detect snow or ice and operates a single boiler, steam valve or electric cable to supply heat to the slab.

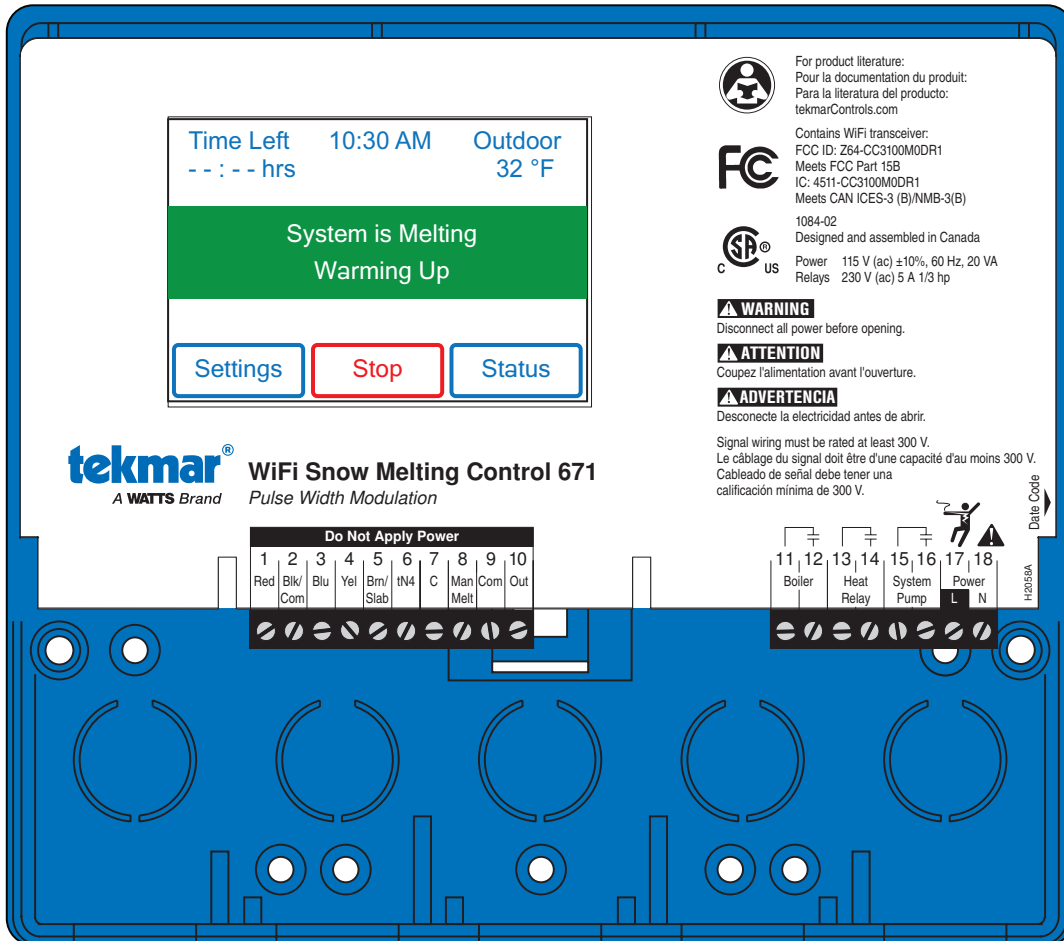

Application	Page
Dedicated Boiler	2
Shared Boiler and Heat Exchanger	4
On/Off Steam Valve	6
Electric Cable	8
Two Zones with Common Mixing	10

**Description**

The WiFi Snow Melting Control 671 operates a boiler that is dedicated for the snow melting system. The system is piped in primary-secondary to allow constant flow rates through the low-mass boiler and filled with glycol to prevent freezing.

- The system pump operates continuously when heating the slab during melting/idling/storm operation.
- The boiler pump cycles on and off together with the boiler.
- The slab temperature is controlled by cycling the boiler on and off.
- The slab target is determined by the melting/idling/storm setpoint and by the measured outdoor air temperature.

The system operation is dependent on sensor selection, as listed in the table below.

Sensor options		Operation methods			
Sensor	Sensor Model(s)	Auto Start/ Auto Stop	Auto Start/ Timed Stop	Manual Start/ Timed Stop	Slab Temperature Control
S1	Automatic Snow/Ice Sensor 090 or 094	•	–	•	•
S2	Aerial Snow Sensor 095	–	•	•	–
S3	Slab Sensor 072 or 073	–	–	•	•
S2+S3	Aerial Snow Sensor 095 and Slab Sensor 072/073	–	•	•	•

**Legend**

- B1 = Boiler
- P1 = System Pump
- P2 = Boiler Pump
- S1 = Snow/Ice Sensor 090 or 094
- S2 = Snow Sensor 095
- S3 = Slab Sensor 072 or 073
- S4 = Outdoor Sensor 070

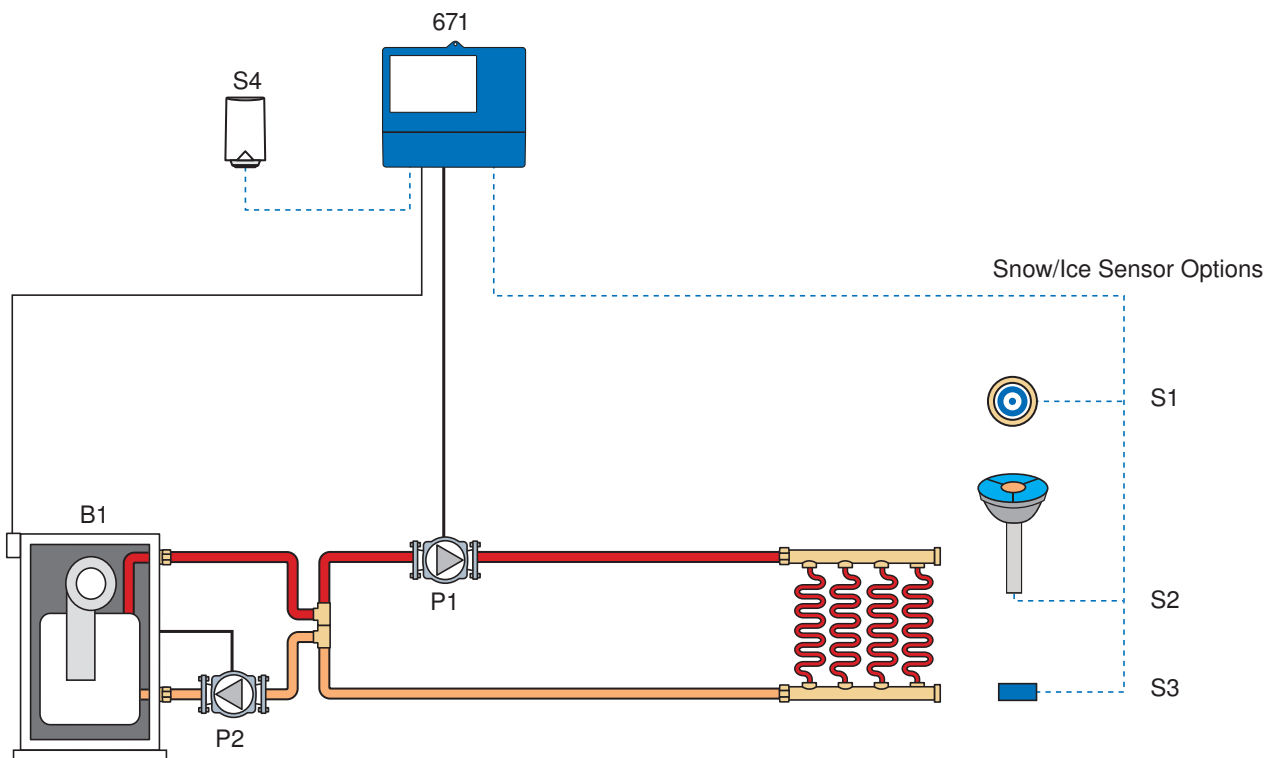

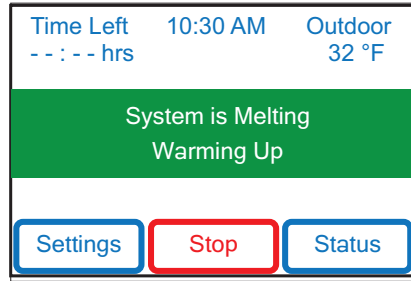

**tekmar**<sup>®</sup> WiFi Snow Melting Control 671  
 A WATTS Brand Pulse Width Modulation



For product literature:  
 Pour la documentation du produit:  
 Para la literatura del producto:  
 tekmarControls.com



Contains WiFi transceiver:  
 FCC ID: Z64-CC3100MODR1  
 Meets FCC Part 15B  
 IC: 4511-CC3100MODR1  
 Meets CAN ICES-3 (B)/NMB-3(B)



1084-02  
 Designed and assembled in Canada  
 Power 115 V (ac) ±10%, 60 Hz, 20 VA  
 Relays 230 V (ac) 5 A 1/3 hp

**WARNING**

Disconnect all power before opening.

**ATTENTION**

Coupez l'alimentation avant l'ouverture.

**ADVERTENCIA**

Desconecte la electricidad antes de abrir.

Signal wiring must be rated at least 300 V.  
 Le câblage du signal doit être d'une capacité d'au moins 300 V.  
 Cableado de señal debe tener una calificación mínima de 300 V.

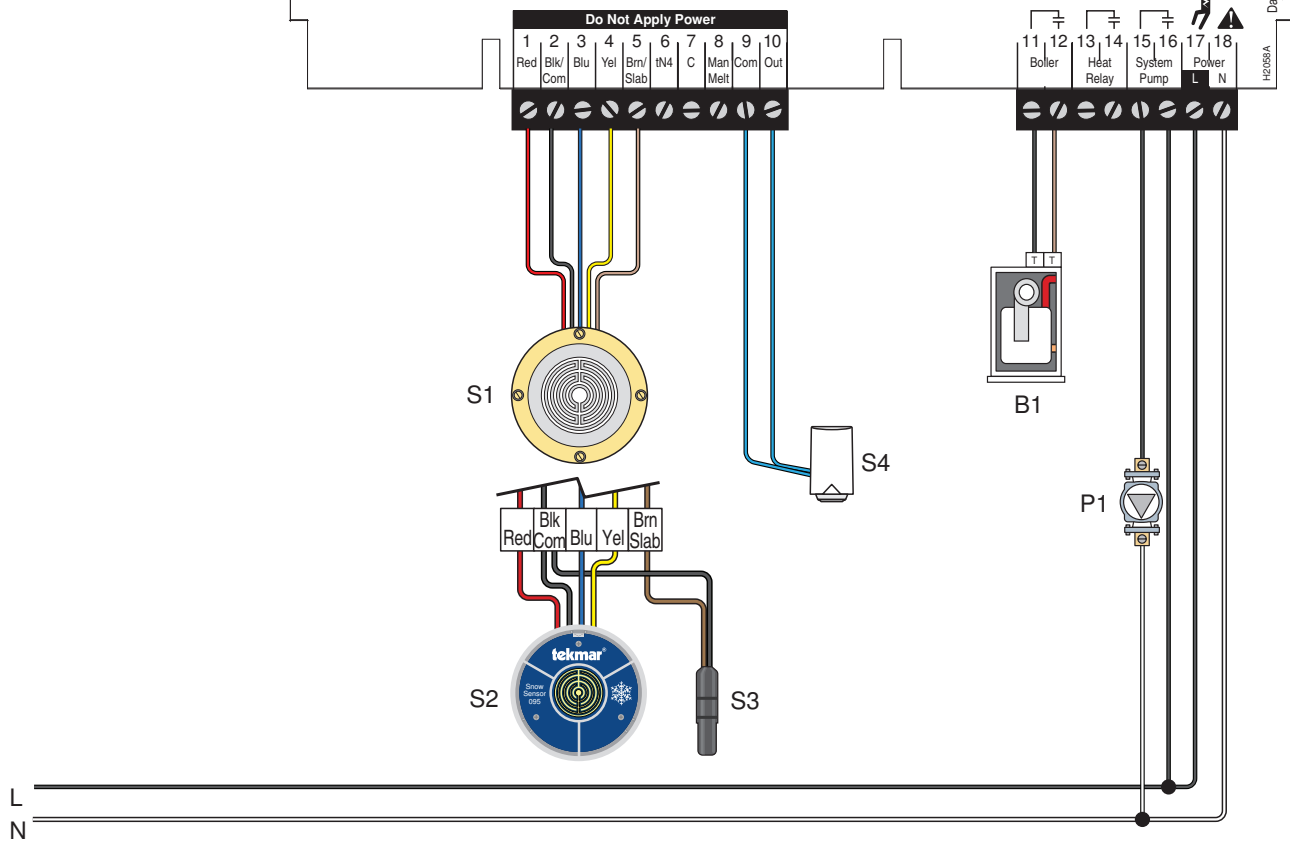

**Description**

The WiFi Snow Melting Control 671 operates a snow melting zone warmed from a heat source that is shared with other loads in a building. A heat exchanger isolates the glycol-filled snow melting system loop from the water-filled main heating system.

- The system pump operates continuously when heating the slab during melting/idling/storm operation.
- The slab temperature is controlled by cycling the boiler on and off.
- The slab target is determined by the melting/idling/storm setpoint and by the measured outdoor air temperature.
- A normally-closed aquastat protects the heat exchanger from freezing by shutting off power to the system pump.

The system operation is dependent on sensor selection, as listed in the table below.

Sensor options		Operation methods			
Sensor	Sensor Model(s)	Auto Start/ Auto Stop	Auto Start/ Timed Stop	Manual Start/ Timed Stop	Slab Temperature Control
S1	Automatic Snow/Ice Sensor 090 or 094	•	–	•	•
S2	Aerial Snow Sensor 095	–	•	•	–
S3	Slab Sensor 072 or 073	–	–	•	•
S2+S3	Aerial Snow Sensor 095 and Slab Sensor 072/073	–	•	•	•

**Legend**

- A1 = Normally Closed Freeze Protection Aquastat
- B1 = Boiler Enable
- HX = Heat Exchanger
- P1 = System Pump
- P2 = On/Off Heat Exchanger Pump
- S1 = Snow/Ice Sensor 090 or 094
- S2 = Snow Sensor 095
- S3 = Slab Sensor 072 or 073
- S4 = Outdoor Sensor 070

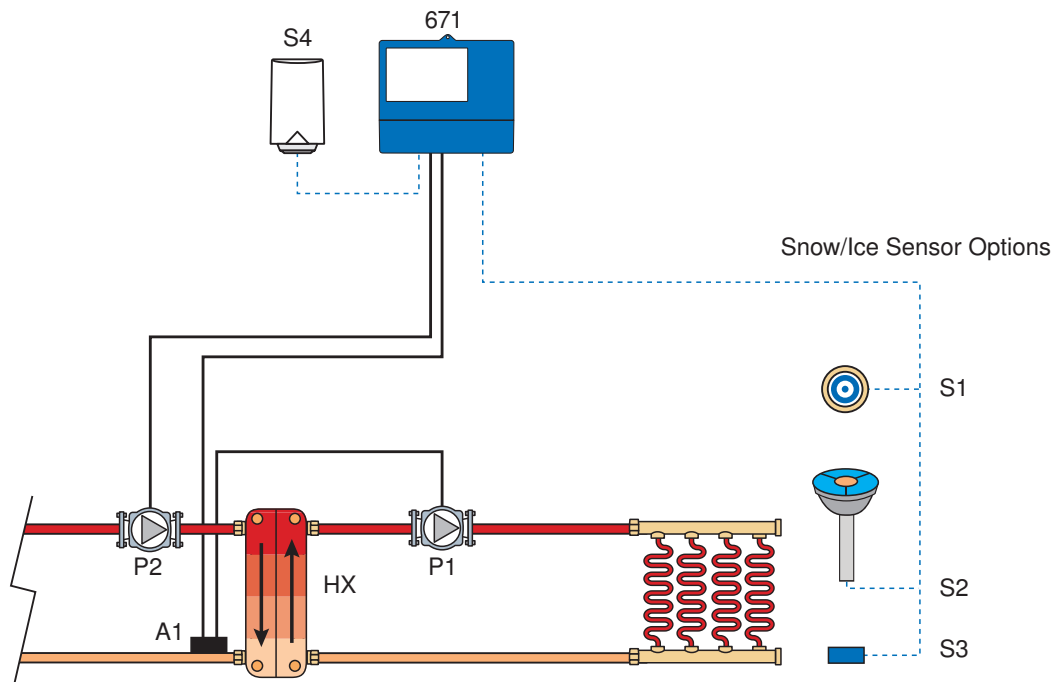

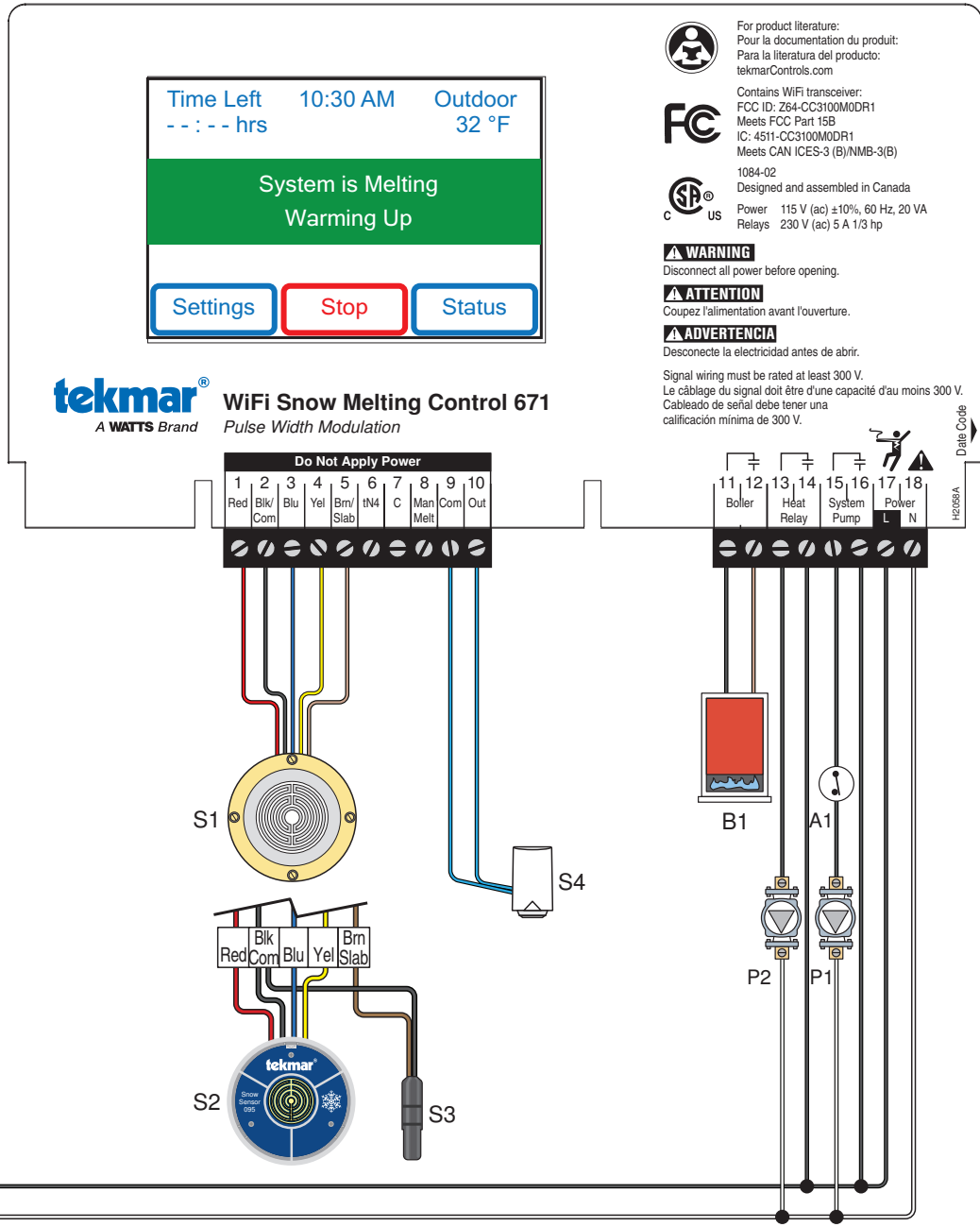

**Description**

The WiFi Snow Melting Control 671 operates a steam valve and a steam-to-water heat exchanger to heat a glycol-filled snow melting system.

- The system pump operates continuously when heating the slab during melting/idling/storm operation.
- The slab temperature is controlled by turning on and off the steam valve.
- The boiler relay is closed while the steam valve is open. This provides a signal to fire the steam boiler.
- The slab target is determined by the melting/idling/storm setpoint and by the measured outdoor air temperature.

The system operation is dependent on sensor selection, as listed in the table below.

Sensor options		Operation methods			
Sensor	Sensor Model(s)	Auto Start/ Auto Stop	Auto Start/ Timed Stop	Manual Start/ Timed Stop	Slab Temperature Control
S1	Automatic Snow/Ice Sensor 090 or 094	•	–	•	•
S2	Aerial Snow Sensor 095	–	•	•	–
S3	Slab Sensor 072 or 073	–	–	•	•
S2+S3	Aerial Snow Sensor 095 and Slab Sensor 072/073	–	•	•	•

**Legend**

- B1 = Boiler Enable
- HX = Steam-to-Glycol Heat Exchanger
- M1 = On/Off Steam Valve
- P1 = System Pump
- S1 = Snow/Ice Sensor 090 or 094
- S2 = Snow Sensor 095
- S3 = Slab Sensor 072 or 073
- S4 = Outdoor Sensor 070

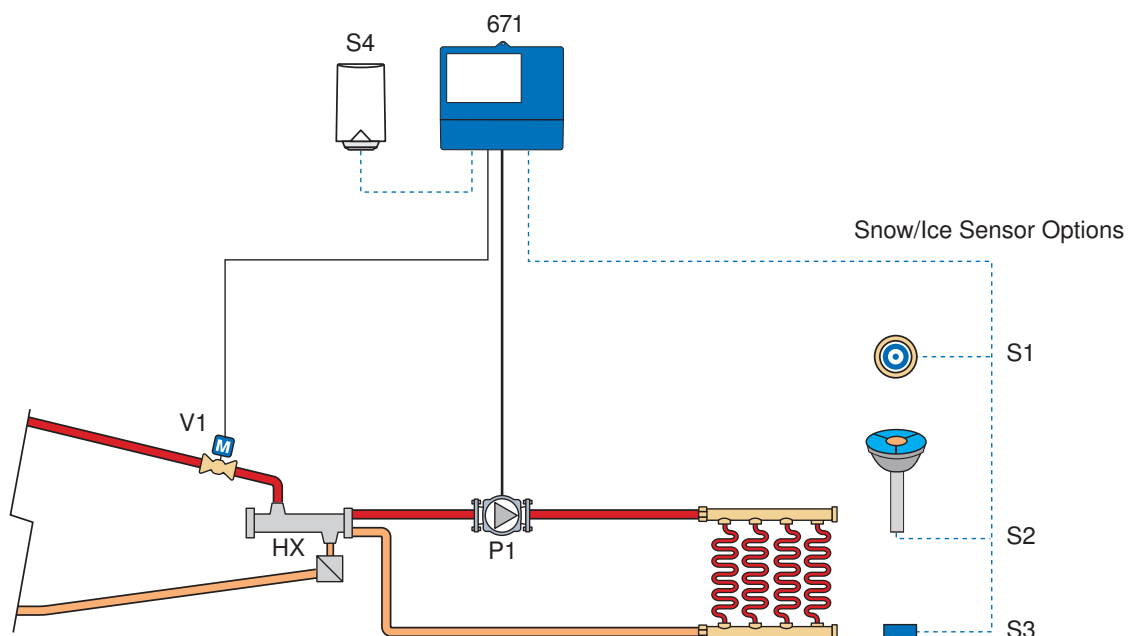

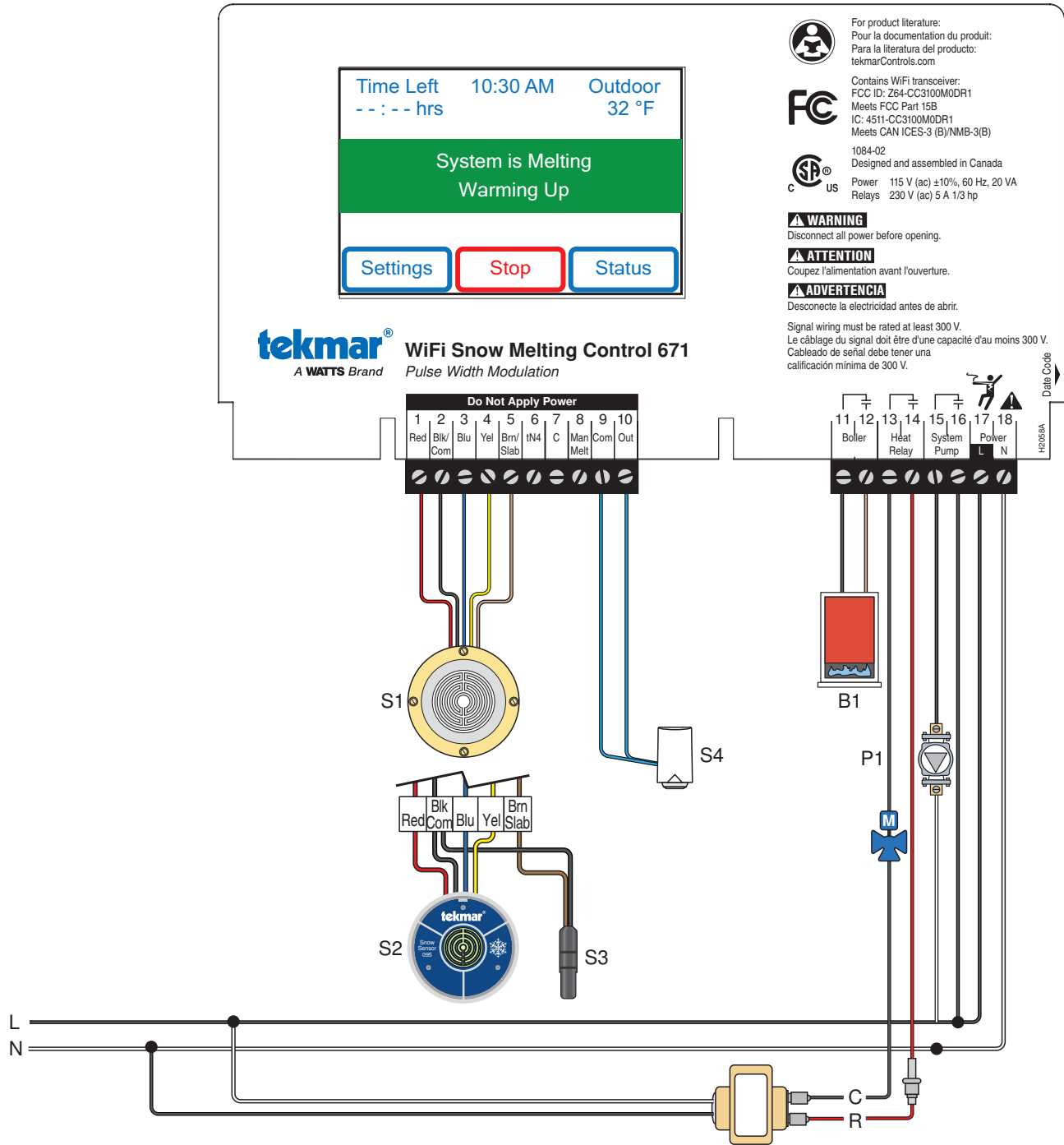

**Description**

The WiFi Snow Melting Control 671 operates an electric cable snow melting system.

- The electric contactor is cycled on and off based on the slab load.

The system operation is dependent on sensor selection, as listed in the table below.

Sensor options		Operation methods			
Sensor	Sensor Model(s)	Auto Start/ Auto Stop	Auto Start/ Timed Stop	Manual Start/ Timed Stop	Slab Temperature Control
S1	Automatic Snow/Ice Sensor 090 or 094	•	–	•	•
S2	Aerial Snow Sensor 095	–	•	•	–
S3	Slab Sensor 072 or 073	–	–	•	•
S2+S3	Aerial Snow Sensor 095 and Slab Sensor 072/073	–	•	•	•

**Legend**

- E1 = 115 or 230 V (ac) Electric Power Supply
- H1 = Electric Heating Cable
- R1 = Electric Relay Contactor
- S1 = Snow/Ice Sensor 090 or 094
- S2 = Snow Sensor 095
- S3 = Slab Sensor 072 or 073
- S4 = Outdoor Sensor 070

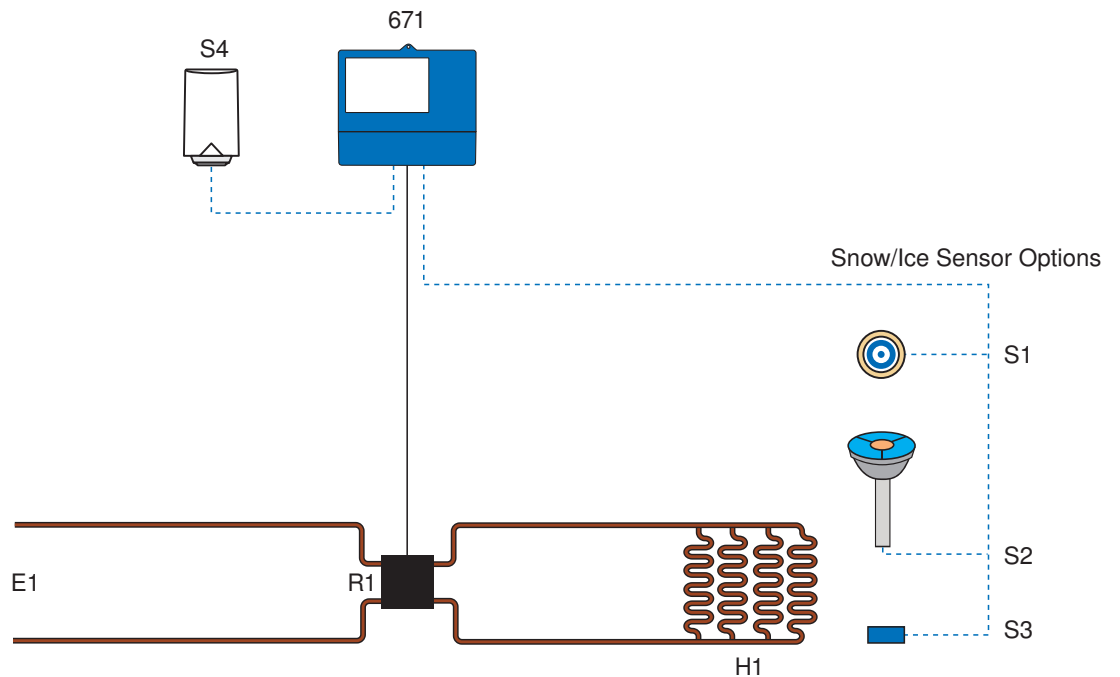



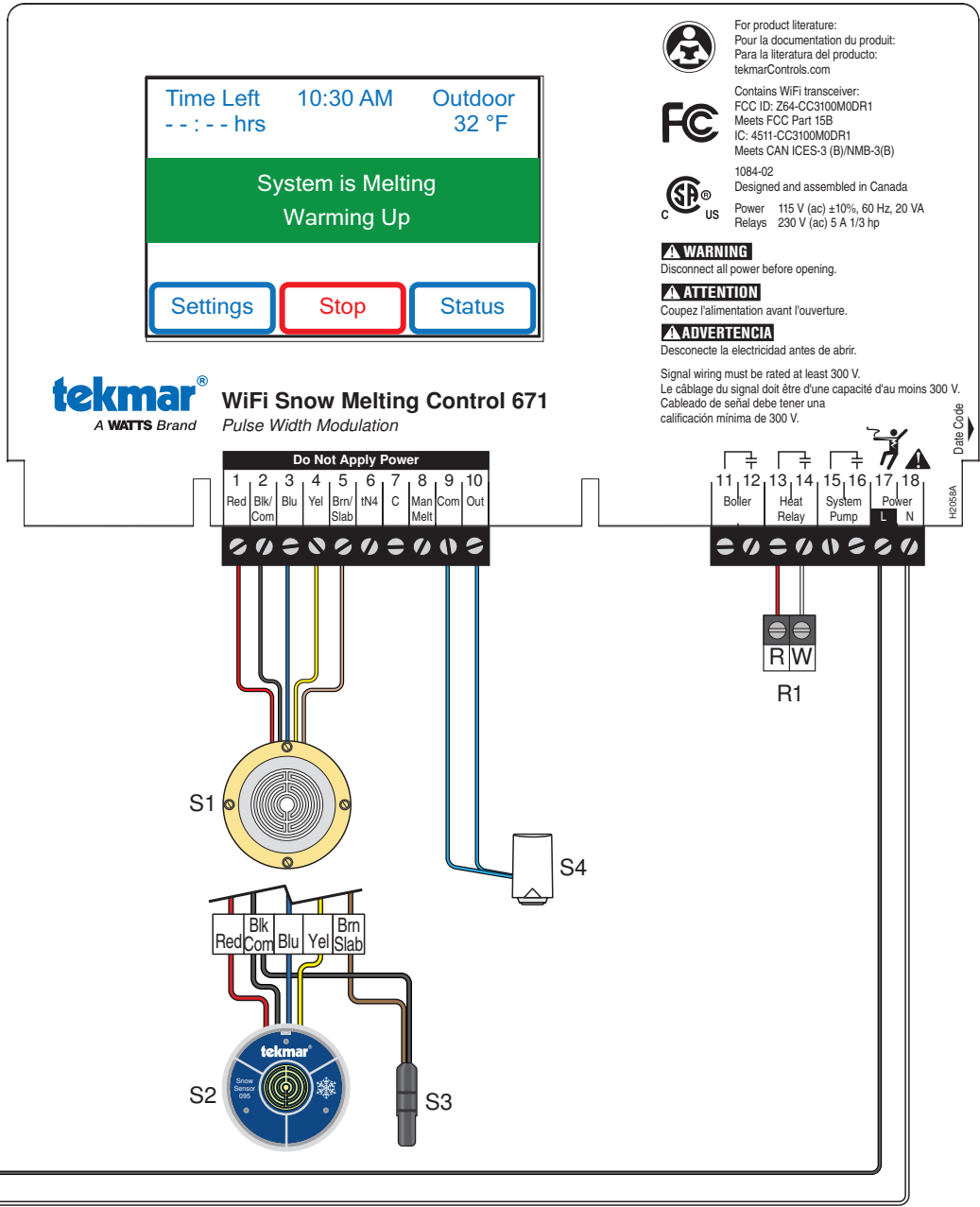

**Description**

The system has two snow melting zones heated by two boilers. The water temperature is regulated by a shared mixing valve for the two snow melting zones. The boilers and mixing valve are operated by a Universal Reset Module 423, Power Manager 346 and Mixing Expansion Module 444. Each snow melting zone is operated by a WiFi Snow Melting Control 671.

- The slab target is determined by the melting/idling/storm setpoint and by the measured outdoor air temperature.
- The zone pump cycles on/off when heating the slab during melting/idling/storm operation.
- When the zone is heated, the 671 communicates to the 423 and 444 to operate the mixing valve and fire the boilers.
- The 423 and 444 close the mixing valve to provide boiler return protection when the boiler supply temperature falls below the 423 boiler minimum setting.

The system operation is dependent on sensor selection, as listed in the table below.

Sensor options		Operation methods			
Sensor	Sensor Model(s)	Auto Start/ Auto Stop	Auto Start/ Timed Stop	Manual Start/ Timed Stop	Slab Temperature Control
S1	Automatic Snow/Ice Sensor 090 or 094	•	–	•	•
S2	Aerial Snow Sensor 095	–	•	•	–
S3	Slab Sensor 072 or 073	–	–	•	•
S2+S3	Aerial Snow Sensor 095 and Slab Sensor 072/073	–	•	•	•

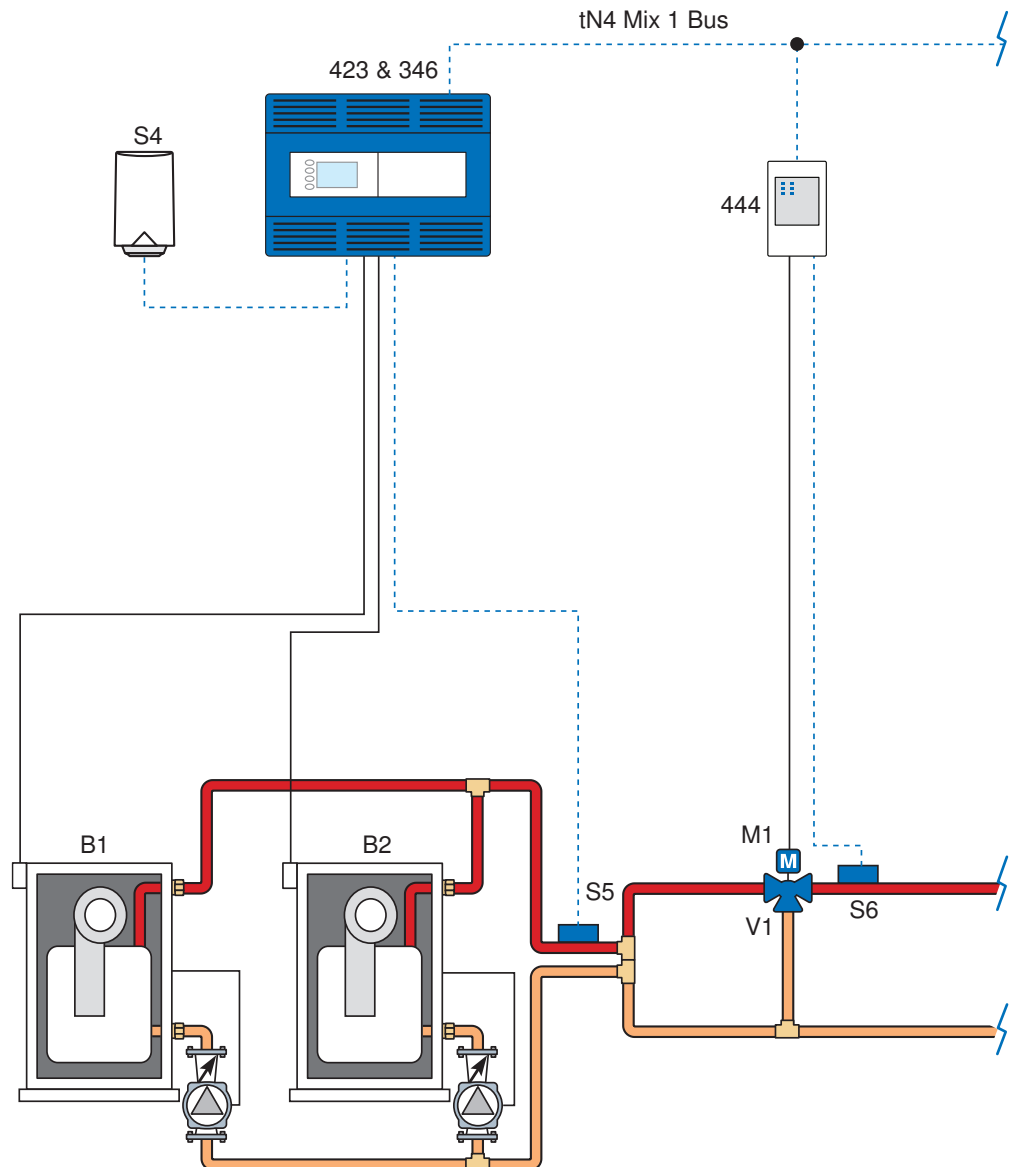

**Legend**

B1, B2 = Modulating Boilers

M1 = Actuator Motor 741

P1 = Zone 1 Pump

P2 = Zone 2 Pump

S1a = Zone 1 Snow/Ice Sensor 090 or 094

S1b = Zone 2 Snow/Ice Sensor 090 or 094

S2a = Zone 1 Snow Sensor 095

S2b = Zone 2 Snow Sensor 095

S3a = Zone 1 Slab Sensor 072 or 073

S3b = Zone 2 Slab Sensor 072 or 073

S4 = Outdoor Sensor 070

S5 = 423 Boiler Supply Sensor 082

S6 = 444 Mix Supply Sensor 082

V1 = 3-Way Mixing Valve 710 through 714

X1 = Transformer 009

**671 Application Settings**

Setting Name	Value
Boiler Type	Control
Outdoor Sensor	tekmarNet

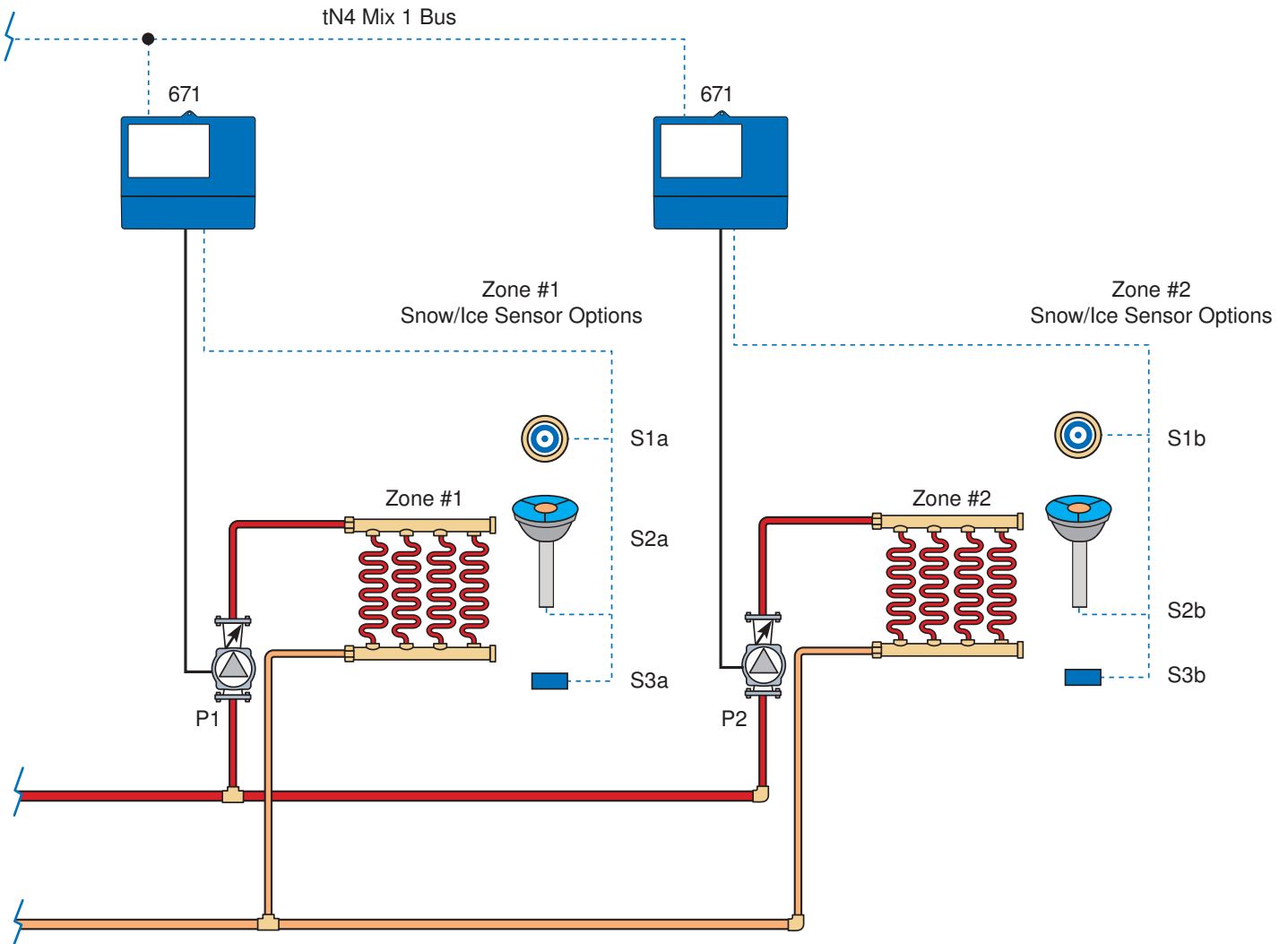

**Legend**

B1, B2 = Modulating Boilers

M1 = Actuator Motor 741

P1 = Zone 1 Pump

P2 = Zone 2 Pump

S1a = Zone 1 Snow/Ice Sensor 090 or 094

S1b = Zone 2 Snow/Ice Sensor 090 or 094

S2a = Zone 1 Snow Sensor 095

S2b = Zone 2 Snow Sensor 095

S3a = Zone 1 Slab Sensor 072 or 073

S3b = Zone 2 Slab Sensor 072 or 073

S4 = Outdoor Sensor 070

S5 = 423 Boiler Supply Sensor 082

S6 = 444 Mix Supply Sensor 082

V1 = 3-Way Mixing Valve 710 through 714

X1 = Transformer 009

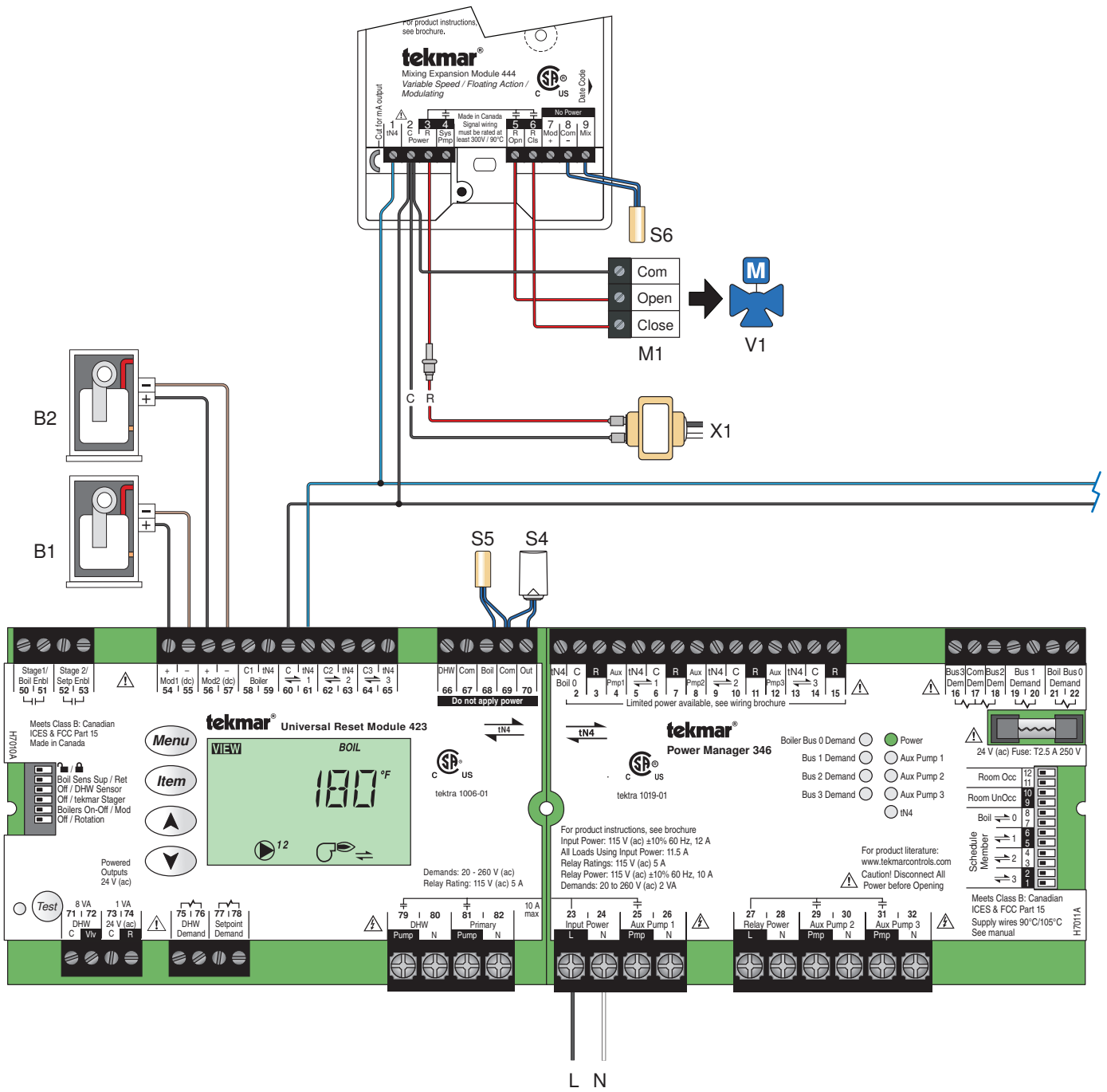

671 Application Settings

Setting Name	Value
Boiler Type	Control
Outdoor Sensor	tekmarNet

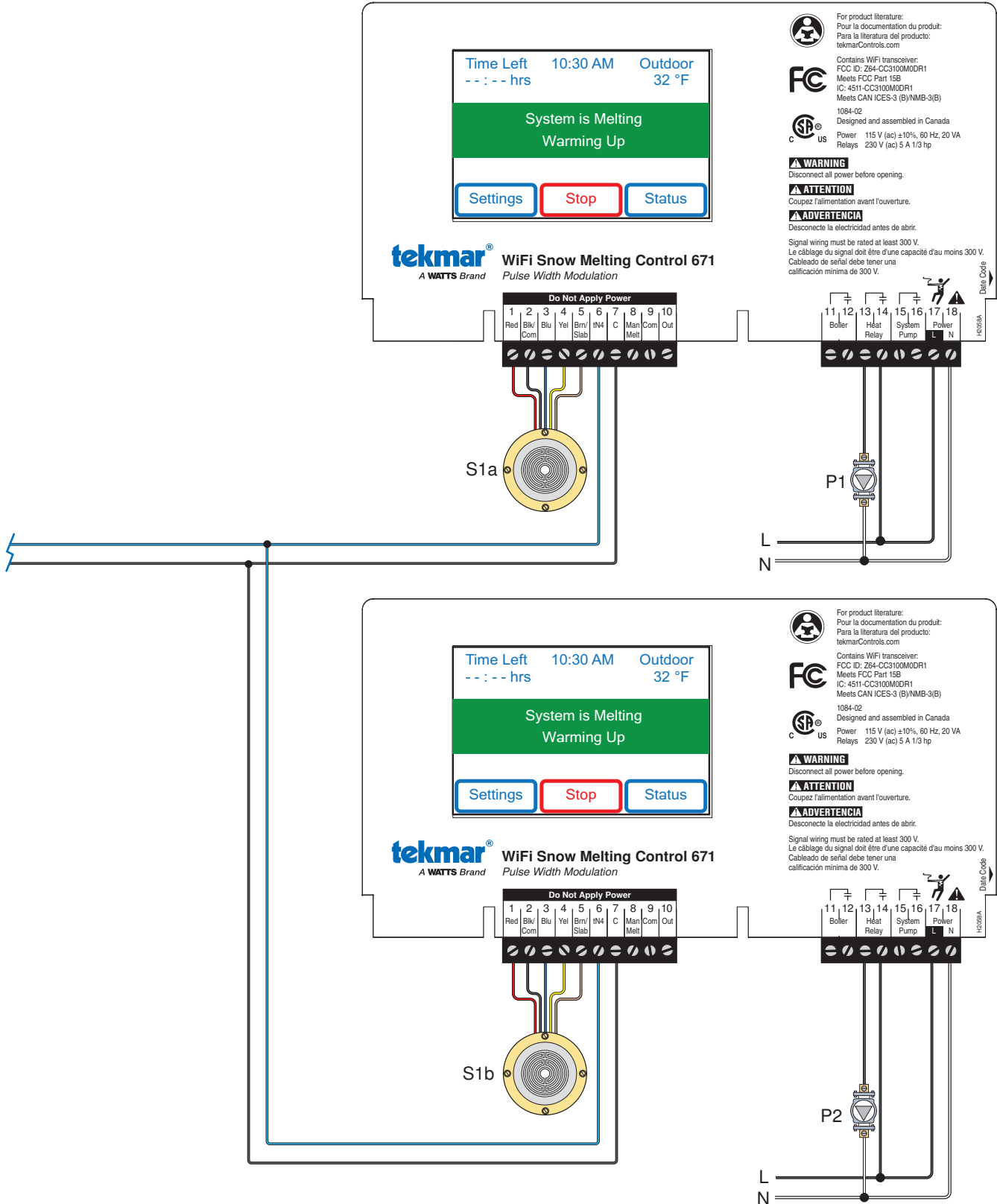

Page left intentionally blank.

Page left intentionally blank.

## Specifications

### The following are the recommended specifications for the WiFi Snow Melting Control 671.

- The control shall have the ability to use a snow/ice sensor in order to automatically detect snow or ice and begin operation of the system. The system shall continue to run until the sensor is dry or the control is manually stopped.
- The control shall have the ability to be manually started with an adjustable running time that counts down and automatically stops the system.
- The control shall not operate the system to provide heat to the snow melting zones when it enters into either a Warm Weather Shut Down (WWSD) or a Cold Weather Cut Off (CWCO) mode.
- The system water temperature shall be based on the outdoor temperature and feedback from sensors located in the snow melting slabs.
- The control shall have two separate access levels to limit the number of adjustments available to various users.
- The control shall have a manual override that allows each output to be manually turned on or off.
- The control shall continuously monitor its temperature sensors and provide an error message upon a control or sensor failure.
- The control shall record and display boiler and pump running hours and minimum and maximum temperatures depending on the access level that has been selected.
- During extended periods of inactivity, the pumps that are operated by the control shall be periodically exercised to prevent seizure during long idle periods.

### **⚠ CAUTION**

This Application Brochure is not intended to provide full installation instructions and safety information. In order to avoid property damage or injury, please refer to the complete installation manual and product safety information provided with the product.



**A WATTS Brand**

All specifications are subject to change without notice

Tel: 1-800-438-3903 • Fax: (250) 984-0815  
tekmarControls.com