

- | | | | | | |
|---|--|--|---|--|--|
| 1 Information Brochure
Choose controls to match application | 2 Application Brochure
Design your mechanical applications | 3 Layout Brochure
Rough-in wiring instructions | 4 Wiring Brochure
Wiring and installation of specific control | 5 Data Brochure
Control settings and sequence of operation | 6 Job Record
Record settings & wiring details for future reference |
|---|--|--|---|--|--|

Overview

The following brochure describes how to wire the tekmar tekmarNet®4 (tN4) thermostat 541. The 541 has outputs for one heat stage. The 541 has inputs for one auxiliary sensor. The wiring of 541 thermostat is simple and cost effective.

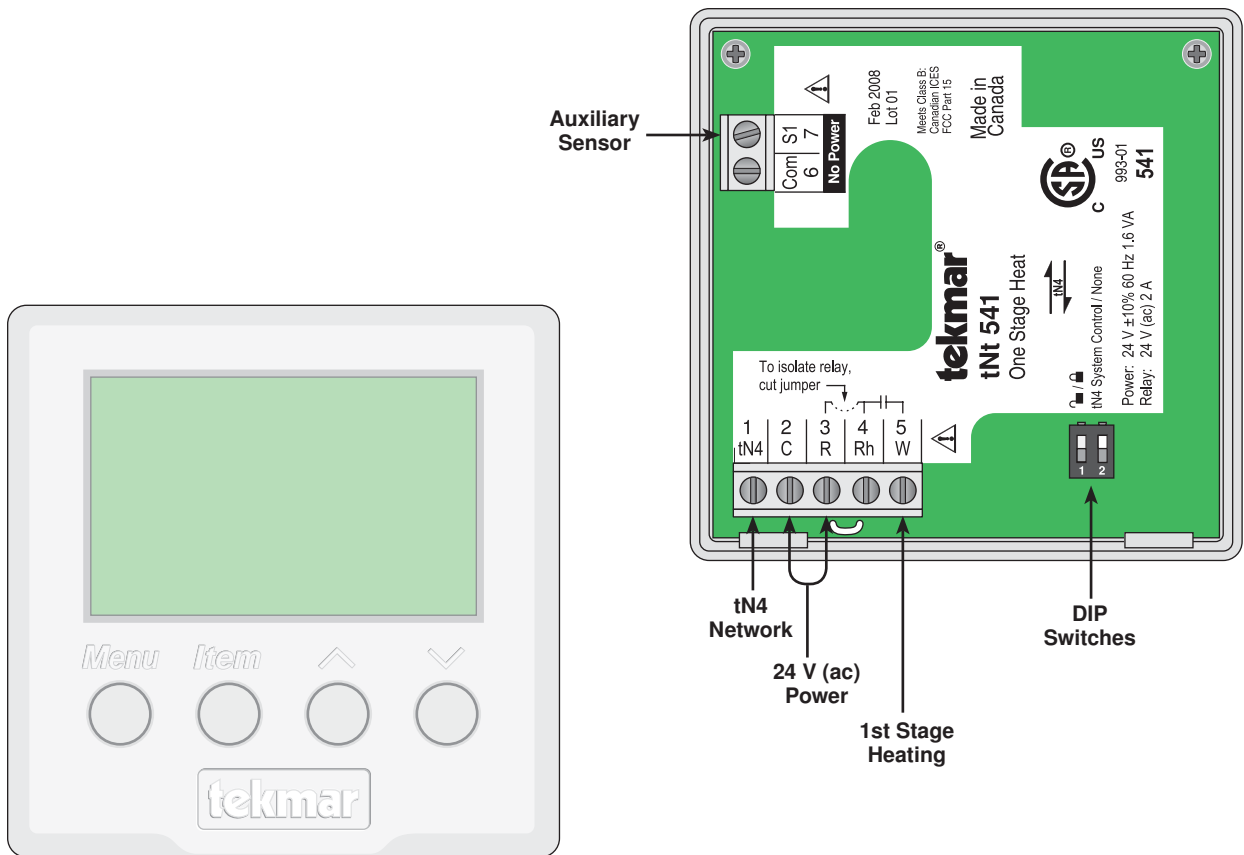

Table of Contents:

Definitions.....	2	Electrical Drawings	3-5
Rough-In Wiring	2	Wiring the Thermostat	6
Remove the Wiring Cover	3	Troubleshooting the Wiring	7
Mounting the Thermostat	3	Testing the Wiring	7
Wiring Symbols.....	3	Technical Data	8

Definitions

The following defined terms and symbols are used throughout this manual to bring attention to the presence of hazards of various risk levels, or to important information concerning the life of the product.



– Caution: Refer to accompanying documents.



– Caution: Refer to accompanying documents.

**INSTALLATION
CATEGORY II**

– Local level appliances.

⚠ Caution ⚠

Improper installation and operation of this control could result in damage to the equipment and possibly even personal injury or death. It is your responsibility to ensure that this control is safely installed according to all applicable codes and standards. This electronic control is not intended for uses as a primary limit control. Other controls that are

intended and certified as safety limits must be placed into the control circuit. Do not attempt to service the control. Refer to qualified personnel for servicing. There are no user serviceable parts. Attempting to do so voids warranty and could result in damage to the equipment and possibly even personal injury or death.

Rough-In Wiring

Choose the placement of the thermostats early in the construction process to enable proper wiring during rough-in.

Consider the following:

- Interior Wall.
- Keep dry. Avoid potential leakage onto the control. RH ≤ 80% to 88°F (31°C), down to 50% from 104 to 122°F (40 to 50°C). Non-condensing environment.
- No exposure to extreme temperatures beyond 32-122°F (0-50°C).

- No draft, direct sun, or other cause for inaccurate temperature readings.
- Away from equipment, appliances, or other sources of electrical interference.
- Easy access for wiring, viewing, and adjusting the display screen.
- Approximately 5 ft. (1.5 m) off the finished floor.

Use standard 18 AWG wire for the thermostat power, stages tN4 and sensor connections.

Refer to the diagram below to determine the number of conductors to run from each piece of equipment to the thermostat location.

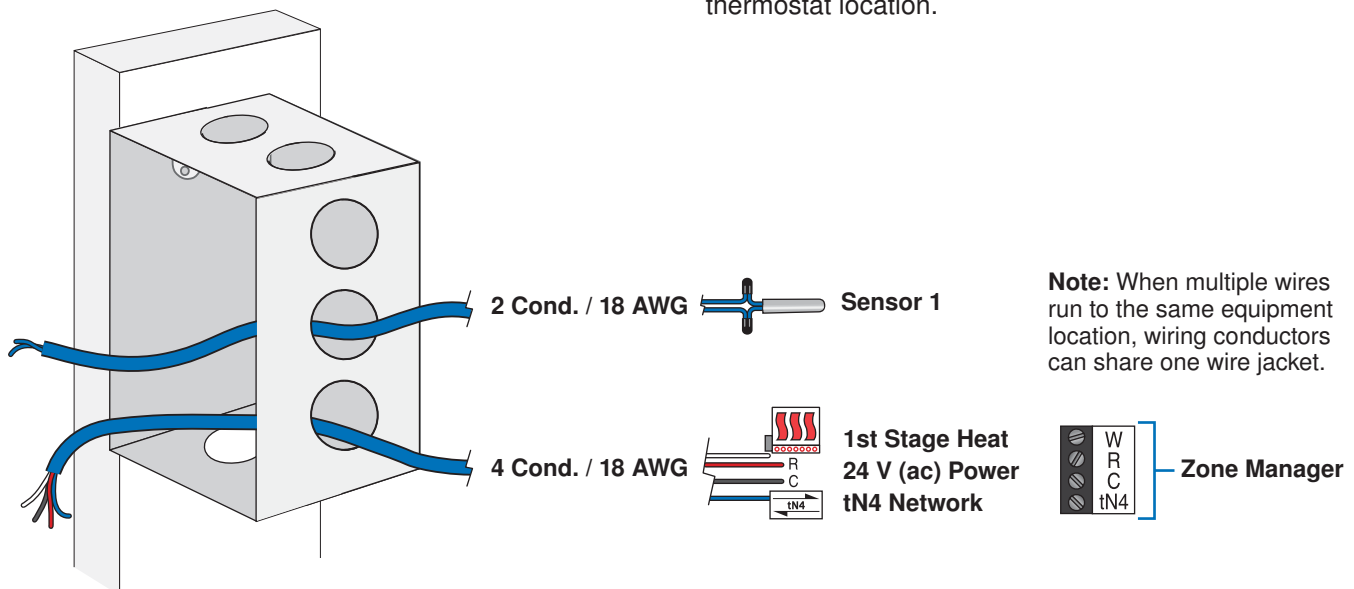

Remove the Wiring Cover:

To remove the wiring cover:

- Place a small slot screwdriver or similar tool into the slot located on the top of the thermostat.
- While pushing against the plastic tab, pull the top of the front cover so that it pivots around the bottom edge of the thermostat's base.

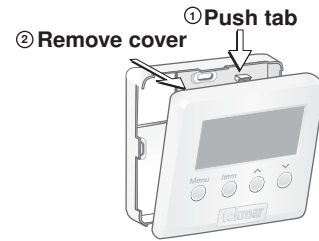

Mounting the Thermostat

If a single gang switch box is used, an Adaptor Plate 007 is required to mount the thermostat to the box.

- Fasten the base of the thermostat to the adaptor plate.
- Feed the wiring through the openings in the back of the adaptor plate and thermostat.
- Use the upper and lower screw holes to fasten the adaptor plate to the box.

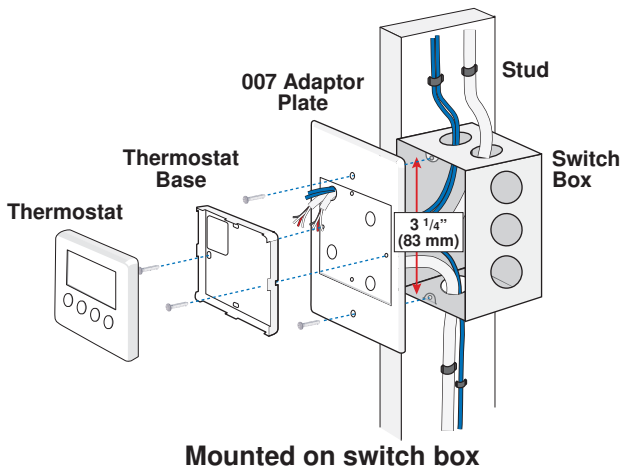

Mounted on switch box

If a switch box was not used, mount the thermostat directly to the wall.

- Feed the wiring through the openings in the back of the thermostat.
- Use screws in the screw holes to fasten the thermostat to the wall. At least one of the screws should enter a wall stud or similar rigid material.

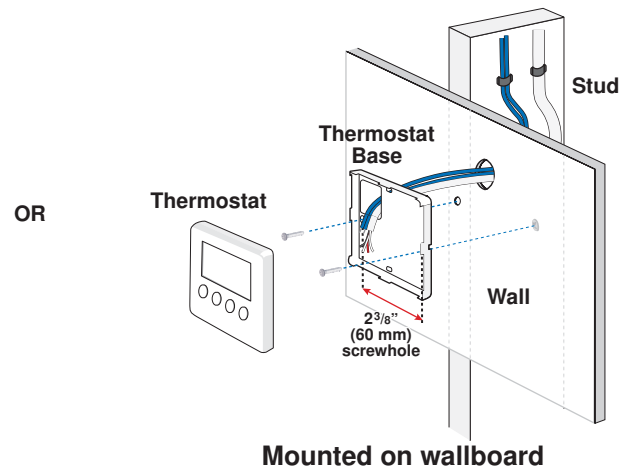

Mounted on wallboard

Wiring Symbols

	Dry contact switch. Operates a device.	Do Not Apply Power	Do not apply power to these terminals. Serious control damage will result.
	Powered switch. 24 V (ac), switched output to valve, pump relay etc.		tekmarNet®4
	Factory jumper.		

⚠ Electrical Drawings

⚠ The electrical drawing examples on the following pages show the 541 in common applications. Choose the drawing that most accurately depicts the components in your system and use that drawing as a guide to aid in wiring your system.

These are only concept drawings, not engineered drawings. They are not intended to describe a complete system nor any particular system. It is up to the system designer to

determine the necessary components for and configuration of the particular system being designed including additional equipment isolation relays (for loads greater than the controls specified output ratings) and any safety devices which in the judgement of the designer are appropriate in order to properly size, configure and design that system and to ensure compliance with building and safety code requirements.

Description:

One Stage Heating (H1 = Radiant).

Legend:

Sensor 1 = Floor

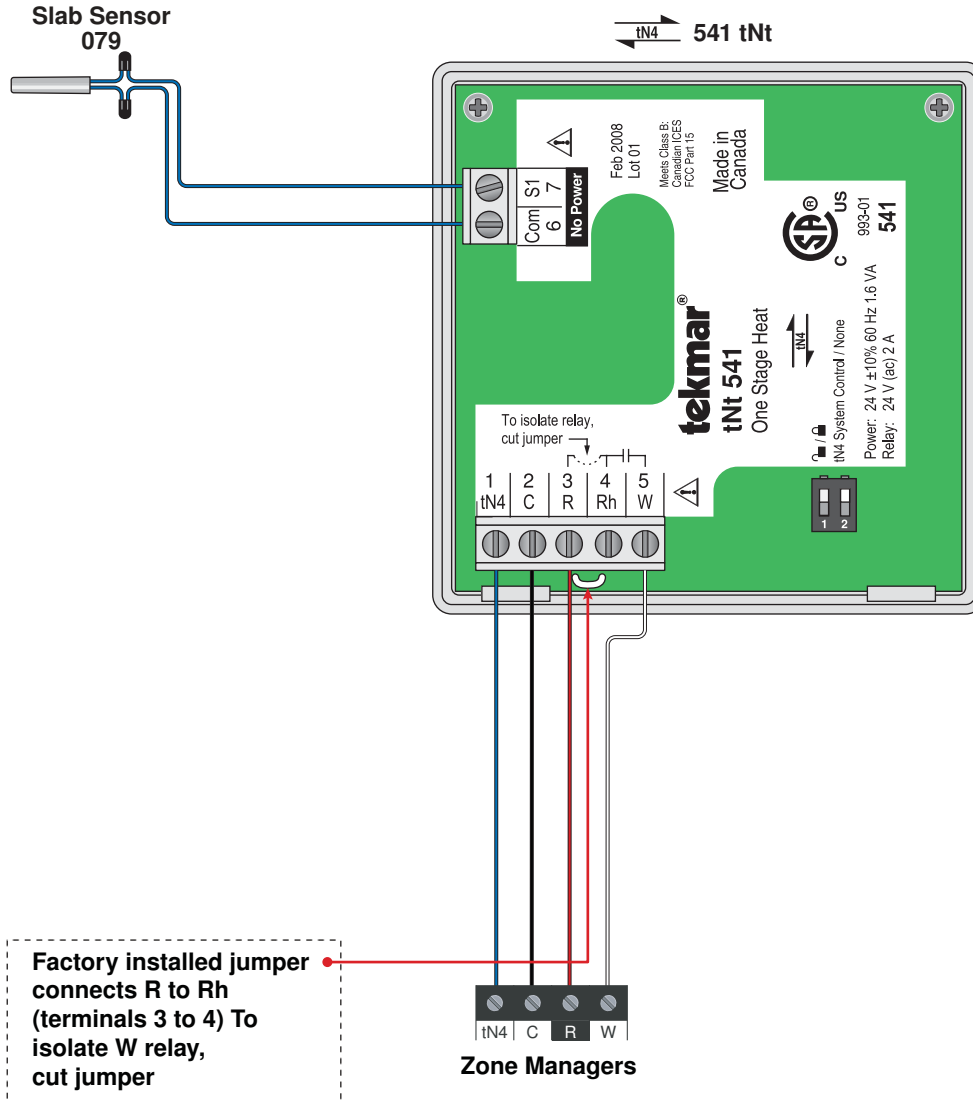

Description:

One Stage Heating (H1 = Fin-tube Convectors).

Legend:

Sensor 1 = Remote

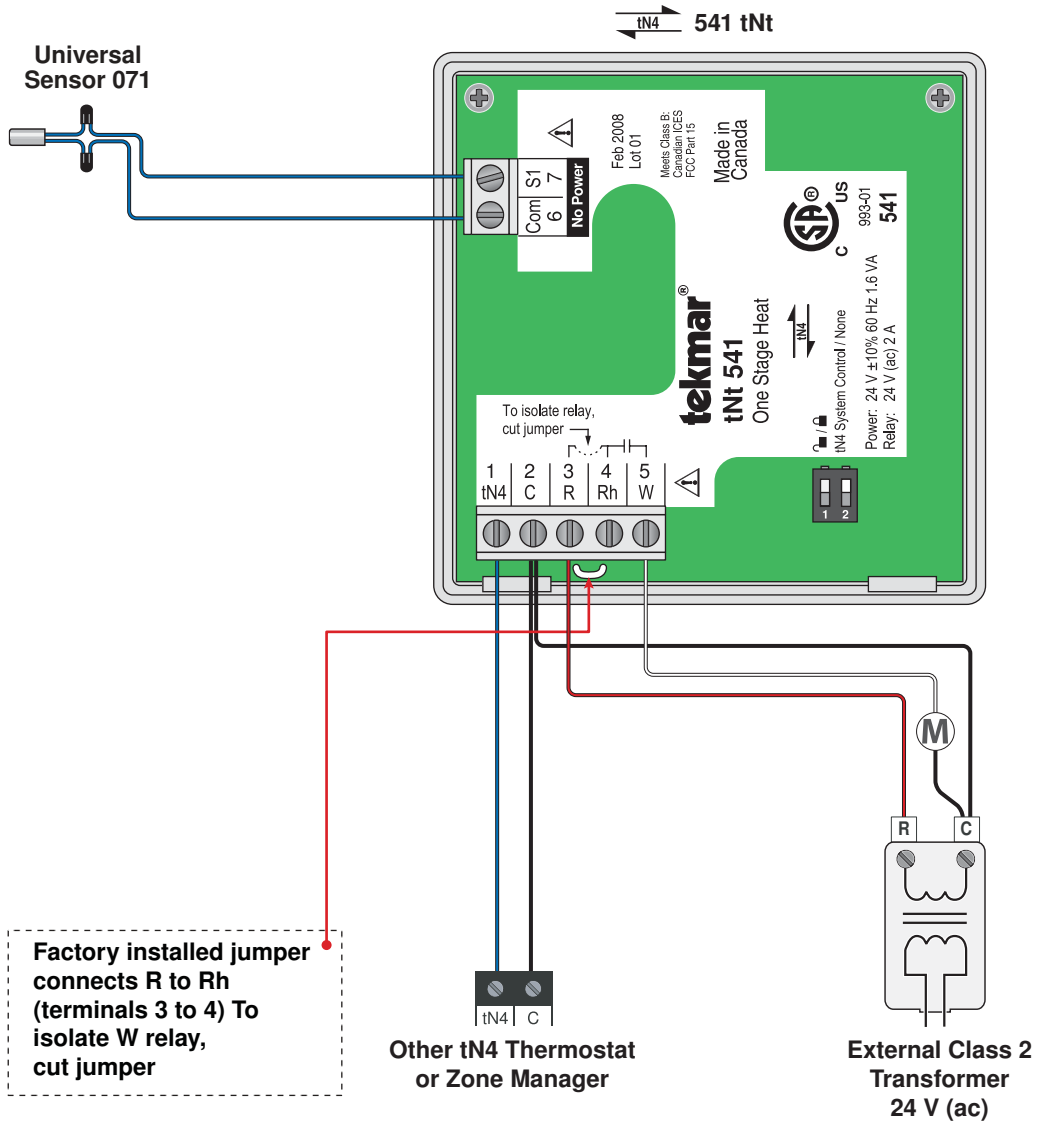

Wiring the Thermostat:

⚠ Power (24 V (ac))

Terminals 2, 3

Wire 24 V (ac) to terminals C and R.

If a Zone Manager is used:

- Connect C on the thermostat to C on the proper zone of the Zone Manager.
- Connect R on the thermostat to R on the proper zone of the Zone Manager.

If a 24 V (ac) transformer is used:

- Connect C on the thermostat to C on the transformer.
- Connect R on the thermostat to R on the transformer.

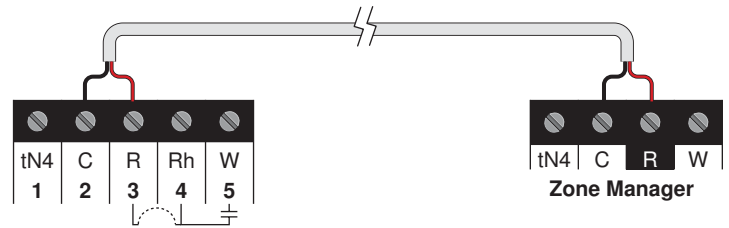

⚠ tN4 Communication

Terminals 1, 2

Wire the tN4 communication to terminals tN4 and C.

If a Zone Manager is used:

- Connect the tN4 on the thermostat to the tN4 on the proper zone of the Zone Manager used for the first stage of heat. The C terminal is already connected.

If a Zone Manager is not used:

- Connect the tN4 on the thermostat to the tN4 on another tN4 device on the same tN4 bus.
- Connect the C on the thermostat to the C terminal on another tN4 device on the same tN4 bus.

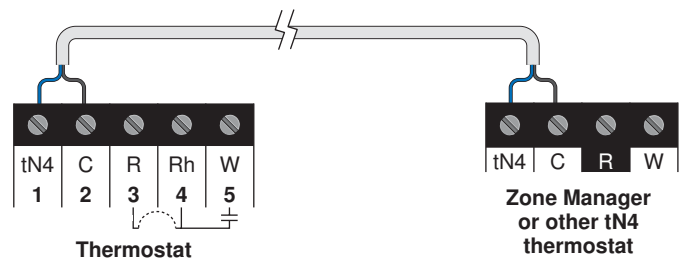

Note: This connection is polarity sensitive.

⚠ Heat 1 Relay

Terminals 3-5

Wire the first stage of heating to the Heat 1 Relay. (Rh-W)

- Use these terminals as a switch to operate the first stage of heating.

If a Zone Manager is used:

- Connect W on the thermostat to W on the proper zone of the Zone Manager.

If a Zone Manger is not used:

- Determine if the factory jumper must be cut.
- When the factory jumper is not cut, W is a powered output that is internally connected to R.
- When the factory jumper is cut, Rh W is an isolated switch. No power is available from these terminals.

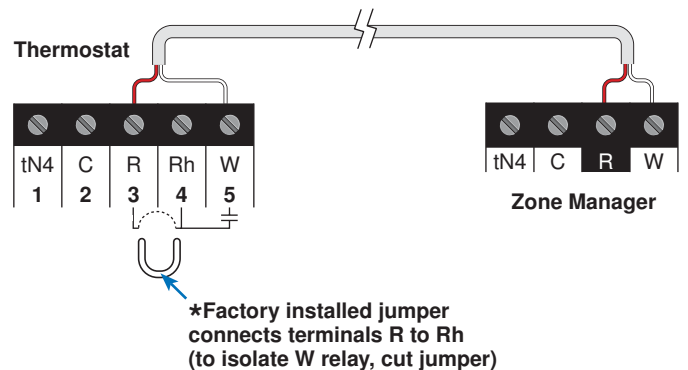

⚠ Auxiliary Sensors

Terminals 6-7

The auxiliary sensor is connected to the thermostat at terminals Com and S1.

Do not apply power to terminals 6-7, permanent damage to the sensors and / or thermostat will result!

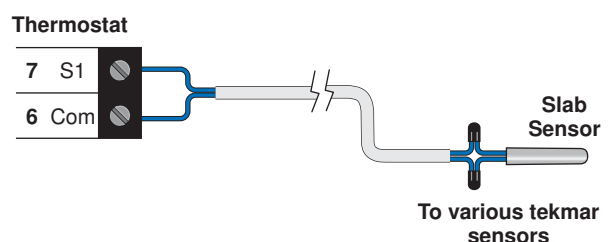

Troubleshooting the Wiring

⚠ General

The following tests are to be performed using standard testing practices and procedures and should only be carried out by properly trained and experienced persons.

A good quality electrical test meter, capable of reading from at least 0-300 V (ac), 0-2,000,000 Ohms, and testing for continuity is essential to properly test the wiring and sensors.

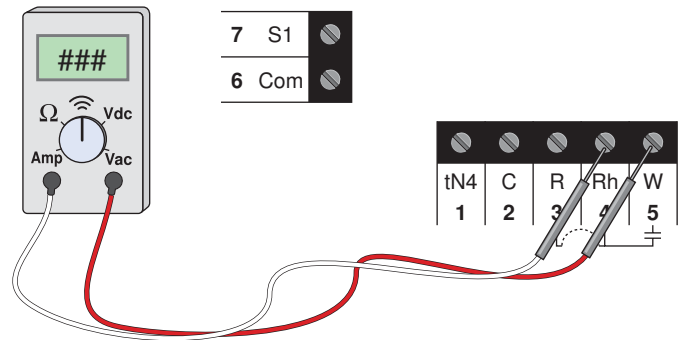

Testing the Wiring

⚠ Testing 24 V (ac) Power Supply

1. Remove the front cover from the thermostat.
2. Use an electrical test meter to measure (ac) voltage between the R and C terminals. The reading should be 24 V (ac) \pm 10%.
3. Install the front cover.

⚠ Testing the Relays

1. Remove the front cover from the thermostat.
2. Disconnect the wires from the relay that is to be tested.
3. Use an electrical test meter and check for continuity across the relay.
 - When the relay's symbol is displayed in the LCD, there should be continuity.
 - When the relay's symbol is not displayed in the LCD, there should be no continuity.
4. Reconnect the wires to the relay.
5. Install the front cover on the thermostat.

541 LCD Display Segments

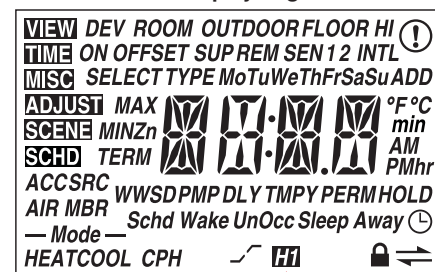

Heat 1

⚠ Testing the Sensor

To test the sensor, the actual temperature at the sensor location must be measured.

Use a good quality digital thermometer with a surface temperature probe for ease of use and accuracy. Where a digital thermometer is not available, place a spare sensor alongside the one to be tested and compare the readings.

1. Remove the front cover from the thermostat.
2. Disconnect the wires from the sensor that is to be tested.
3. Test the sensor's resistance according to the instructions in the sensor Data Brochure D 070, D 074 or D 079.
4. Reconnect the wires.
5. Install the front cover on the thermostat.

⚠ Testing the tN4 Network

To test the tN4 Network, check the wires for continuity.

1. Remove the front cover from the thermostat.
2. Disconnect the two wires (tN4 and C) at one end and connect them together.
3. Go to the other end of the wires and disconnect them.
4. Using an electrical test meter, check for continuity.
5. Reconnect the wires.
6. Install the front cover on the thermostat.

Technical Data

tekmarNet®4 Thermostat 541: *One Stage Heat*

Control	Microprocessor PID control; This is not a safety (limit) control
Packaged weight	0.46 lb. (210 g)
Enclosure	White PVC plastic
Dimensions	2-7/8" H x 2-7/8" W x 13/16" D (73 x 73 x 21 mm)
Approvals	CSA C US, CSA/UL 61010-1, meets Class B: ICES and FCC Part 15
Ambient conditions	Indoor use only, 32 to 122°F (0 to 50°C)
	RH ≤ 80% to 88°F (31°C), down to 50% from 104 to 122°F (40 to 50°C)
	Altitude <6560 feet (2000 m), Installation Category II, Pollution Degree 2
Power supply	24 V (ac) ± 10% 60 Hz, 1.6 VA, NEC / CEC Class 2
W1 Relay	24 V (ac) 2 A
Sensors:	NTC thermistor, 10 kΩ @ 77°F (25°C ± 0.2°C) β = 3892
– Included	None
– Optional	tekmar type # 071, 070, 072, 073, 076, 077, 078, 079, 082, 084

The installer must ensure that this control and its wiring are isolated and/or shielded from strong sources of electromagnetic noise. Conversely, this Class B digital apparatus complies with Part 15 of the FCC Rules and meets all requirements of the Canadian Interference-Causing Equipment Regulations. However, if this control does cause harmful interference to radio or television reception, which is determined by turning the control off and on, the user is encouraged to try to correct the interference by re-orientating or relocating the receiving antenna, relocating the receiver with respect to this control, and/or connecting the control to a different circuit from that to which the receiver is connected.

Cet appareil numérique de la classe B respecte toutes les exigences du Règlement sur le matériel brouilleur du Canada.



tekmar Control Systems Ltd., Canada
 tekmar Control Systems, Inc., U.S.A.
Head Office: 5100 Silver Star Road
Vernon, B.C. Canada V1B 3K4
(250) 545-7749 Fax. (250) 545-0650
Web Site: www.tekmarcontrols.com