

tekmar[®] - Data Brochure

D 512

Programmable Thermostat 512

09/09

Table of Contents

Display / Keypad Operation.....	pg 1	View Menu.....	pg 6
Display Symbols	pg 2	Adjust Menu	pg 7-10
General	pg 2-3	Error Messages	pg 11
Sequence of Operation.....	pg 4-6	Installation.....	pg 12-13
Type 512 (Two Stage Heating)...	pg 4	Wiring the 512	pg 14-17
Type 512 (Heat / Cool)	pg 5-6	Warranty	pg 20
Menus	pg 6-10		

Display / Keypad Operation

The thermostat's display has four distinct fields. These fields are the **Menu** field, the **Item** field, the **Number** field and the **Status** field. The four buttons on the face of the thermostat are used to navigate through the menus and items to view and / or adjust the desired settings.

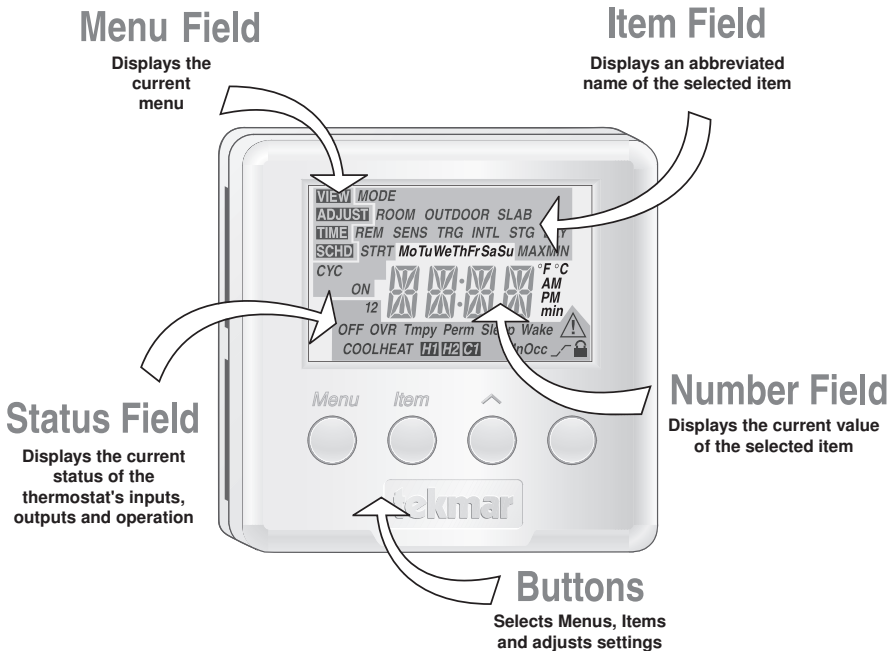

Display Symbols



Warning

Displays when an error exists.

H1

Heat One

Displays when the heat one contact is on.



Access Level

Displays when in the user access level.

H2

Heat Two

Displays when the heat two contact is on.



Early Start

Displays when the thermostat is in early start.

C1

Cool One

Displays when the cool one contact is on.

General

CYCLES PER HOUR (HEAT CYCLE and COOL CYCLE)

The thermostat operation is based on cycles per hour. The number of cycles per hour is adjustable through the HEAT CYCLE and COOL CYCLE settings in the Adjust menu. During each cycle that heating or cooling is required, the thermostat turns on the Heat or Cool relay(s) for a calculated amount of time. This amount of time is the “on time”. The on time is calculated based on the requirements of the zone. If the zone requires more heating or cooling, the appropriate on time is increased. If the zone requires less heat or cooling, the appropriate on time is reduced.

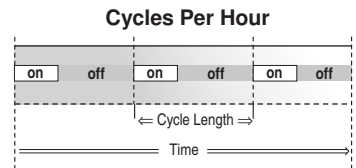

In order to prevent short cycling of the heating relay(s), the thermostat ensures that the relay(s) remains on or off for a minimum amount of time. In order to prevent short cycling of the Cool relay, the minimum cooling on time and minimum cooling off time settings are adjusted in the Adjust menu of the 512.

An Auto Cycle setting is available for both the heating cycle and the cooling cycle. This setting allows the thermostat to determine the best number of cycles per hour that balances both temperature swings and equipment cycles.

EARLY START ()

Heating - The early start function for heating ensures that the zone is up to the proper temperature at the beginning of each period. The thermostat learns the recovery rate over multiple setback events in order to determine the proper lead time for the zone. If both an air sensor and a slab sensor are used, the lead time is the greater of the air sensor's or the slab sensor's requirements.

Cooling - The early start function, when used with cooling, allows the cooling system to turn on 30 minutes prior to the beginning of a period that requires cooling.

NOTE: The Early Start feature occurs when the schedule changes from a low temperature to a higher temperature.

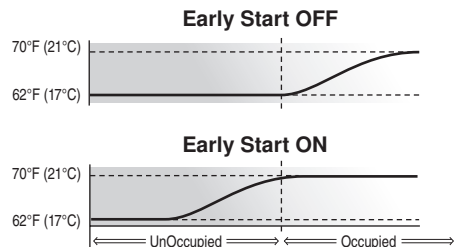

AUXILIARY SENSORS

The thermostat has a single built-in sensor to measure air temperature at the thermostat. In addition to the built-in sensor, the thermostat has terminals to connect up to two separate sensors. These sensors can be either indoor sensors, slab sensors, a remote sensor, or an outdoor sensor.

Indoor Sensor

An indoor sensor is used to measure the air temperature in the zone that the thermostat is controlling. The temperature being read by the indoor sensor is used in the calculations of the on times for the relay(s) in the thermostat. Either one or both of the auxiliary sensor inputs can be configured for indoor sensors. This setting is made through the Adjust menu of the thermostat. If more than one sensor, either the built-in sensor or an auxiliary sensor set as an indoor sensor, is being used to measure the zone temperature, the temperature of the active sensors is averaged and used to calculate the on time of the relay(s).

Slab Sensor

A slab sensor is used to measure the slab temperature in the zone that the thermostat is controlling. The temperature being read by the slab sensor is used in the calculations of the on time for the Heat relay and allows the thermostat to operate the slab between the slab minimum and slab maximum settings. If more than one slab sensor is used, the slab temperatures are averaged by the thermostat.

Remote Sensor

A single remote sensor can be connected to the thermostat. The temperature measured by a remote sensor does not affect the on time of the relays and is only used for display purposes.

Outdoor Sensor

A single outdoor sensor can be connected to the thermostat. The temperature measured by an outdoor sensor does not affect the on time of the relays and is only used for display purposes.

ACCESS LEVELS

The tekmar Programmable Thermostat has two access levels. These access levels restrict the number of items available in the menus of the thermostat. The two access levels are User and Installer. This selection is made using the DIP switch located on the circuit board inside the thermostat.

The Installer access level allows the installer to adjust all of the settings in the thermostat including those required to match the thermostat to the mechanical system and the devices used.

The User access level allows the end user to adjust the time, temperatures and schedules used by the thermostat.

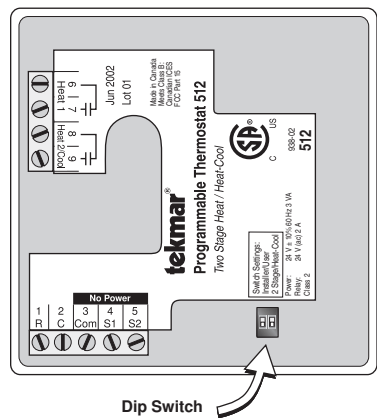

TWO STAGE HEAT

The two stage mode of operation is selected using the DIP switch located on the circuit board inside the thermostat.

In cases where a one stage heating system can not provide sufficient heat under all conditions, a second stage of heat can be added to supplement the first stage. A two stage system therefore has one thermostat controlling two output relays.

Two Stage Logic

The temperature in a two stage zone is controlled by varying the on time of the Heat 1 and Heat 2 relays during a cycle. Under light loads, the Heat 1 relay is cycled on and off. As the load increases, the Heat 1 relay on time is increased until it reaches the maximum of the cycle length or, if a slab sensor is used, the slab temperature reaches the slab maximum setting. The Heat 2 relay is then cycled and its on time is increased as the load increases. When the heating load decreases, the on time of the Heat 2 relay is reduced until the Heat 2 relay is turned off completely. The thermostat then reduces the on time of the Heat 1 relay.

NOTE: When using a slab sensor, the Heat 2 relay may be on while the Heat 1 relay is off if the slab temperature has reached the slab maximum setting.

Air Sensor(s) Only Operation

When operating with only an air sensor, the on times for the Heat 1 and Heat 2 relays are calculated to satisfy the requirements of the air sensor.

Slab Sensor Only Operation

When operating with only a slab sensor, the on times for the Heat 1 and Heat 2 relays are calculated to satisfy the requirements of the slab sensor. The thermostat operates to maintain the slab at the minimum slab temperature setting.

NOTE: Operating with only a slab sensor can lead to either overheating or underheating of the space.

Air and Slab Sensor Operation

When operating with both air and slab sensors, the thermostat calculates an on time for the Heat 1 relay to satisfy the slab sensor's requirements and on times for the Heat 1 and Heat 2 relays to satisfy the air sensor's requirements. The thermostat operates the Heat 1 relay for the longer of these two on times.

While the minimum slab temperature is satisfied, the on times of the Heat 1 and Heat 2 relays are calculated to satisfy the air temperature requirements.

During heavy loads, the maximum slab temperature setting limits the on time of the Heat 1 relay. In this situation, the Heat 2 relay may be on while the Heat 1 relay is off.

NOTE: During light heating loads, overheating can occur due to the minimum slab temperature requirements.

Mode

Heat In the heat mode, the Heat 1 and Heat 2 relays are operated to satisfy the temperature requirement of the zone.

Off In the Off mode, the Heat 1 and Heat 2 relays are not operated.

NOTE: If an air or slab sensor is active in the Off mode, a freeze protection is enabled that allows the relays to be operated to keep the zone above 35°F (2°C).

HEAT / COOL

The Heat / Cool mode of operation is selected using the DIP switch located on the circuit board inside the thermostat.

Air Sensor(s) Only Operation

When operating with only an air sensor, the on times of the Heat 1 relay and the Cool relay are calculated to satisfy the requirements of the air sensor.

Slab Sensor Only Operation

When operating with only a slab sensor, the on time of the Heat 1 relay is calculated to satisfy the requirements of the slab sensor. The thermostat operates to maintain the slab at the minimum slab temperature setting.

NOTE: When operating with only a slab sensor, the Cool relay does not operate. Operating with only a slab sensor can lead to either overheating or underheating of the space.

Air and Slab Sensor Operation

When operating with both air and slab sensors, the thermostat calculates an on time for the Heat 1 relay to satisfy the slab sensor's requirements and an on time to satisfy the air sensor's requirements. The Heat 1 relay operates for the longer of these two on times. The thermostat also calculates an on time for the Cool relay to satisfy the air sensor's requirements. In this situation, heating and cooling can happen at the same time to prevent the space from overheating. This is most likely to occur when the slab is operating at the slab minimum temperature.

While the minimum slab temperature is satisfied, the Heat 1 relay on time is calculated to satisfy the air temperature setting. However, the maximum slab temperature setting limits the Heat 1 relay on time when the slab temperature becomes too warm. In this situation, underheating can occur in the space.

Mode

Auto In the Auto mode, the thermostat automatically switches between heating and cooling the space. However, the heating operation has priority over the cooling operation. In this mode, the minimum slab temperature is maintained even when the thermostat is cooling the air.

Heat In the Heat mode, the Heat 1 relay is operated to satisfy the heating temperature requirement of the zone and cooling is disabled.

Cool In the Cool mode, the Cool relay is operated to satisfy the cooling temperature requirement of the zone and heating is disabled. If a slab sensor is used, the slab minimum is ignored.

Off In the Off mode, the Heat 1 and Cool relays are not operated.

NOTE: If an air or slab sensor is active in the Off mode, a freeze protection is enabled that allows the Heat 1 relay to be operated to keep the zone above 35°F (2°C).

Time Interlock

In order to prevent frequent changes between heating and cooling, the thermostat has a Cooling Interlock setting. Once the Heat 1 relay has been off for a minimum of one heating cycle or the length of the Cooling Interlock, (whichever is longer) cooling is permitted.

Temperature Interlock

When in the Auto mode, the cooling temperature is limited to 3°F (1.5°C) above the heating temperature. If the cooling temperature is set below the heating temperature, the thermostat automatically adjusts the cooling setpoint.

When operating in the Cool mode, there is no interlock between the heating and cooling temperature.

View Menu (1 of 1)

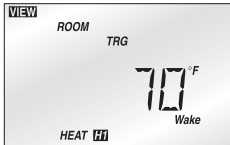

ROOM TARGET

The current desired air temperature for the space. This item is only available in the Installer access level.
(Must have an active air sensor.)

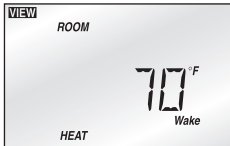

ROOM

The current air temperature for the space.
(Must have at least one active air sensor. This is the average of all active air sensors.)



OUTDOOR

The current temperature at the outdoor sensor .
(Sens 2 must be set to Out.)



SLAB

The current slab temperature.
(Must have an active slab sensor. If two slab sensors are present, this is the average temperature.)

The MIN segment is displayed when running on Min.



REMOTE

The current temperature at the remote sensor.
(Sens 1 must be set to Rem.)

Adjust Menu (1 of 4)

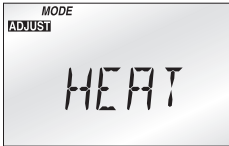

MODE

Current mode of operation of the thermostat.

OFF, HEAT

OFF, COOL, AUTO, HEAT

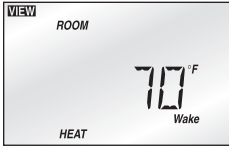

ROOM HEAT (No Schedule)

Desired temperature for heating.

(Must have an active air sensor and be set to either Heat or Auto.)

35 to 100°F (1.5 to 38.0°C)



ROOM COOL (No Schedule)

Desired temperature for cooling.

(Must have an active air sensor and be set to either Cool or Auto.)

35 to 100°F (1.5 to 38.0°C)



SLAB MINIMUM (No Schedule)

Minimum slab temperature.

(Must have an active slab sensor.)

OFF, 34 to 122°F (OFF, 1.0 to 50.0°C)

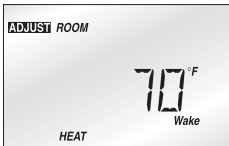

ROOM HEAT WAKE

Desired temperature for heating during Wake.

(Must have an active air sensor and be set to either Heat or Auto.)

35 to 100°F (1.5 to 38.0°C)

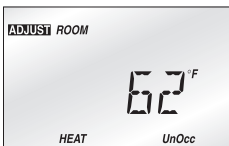

ROOM HEAT UnOcc

Desired temperature for heating during UnOccupied.

(Must have an active air sensor and be set to either Heat or Auto.)

35 to 100°F (1.5 to 38.0°C)

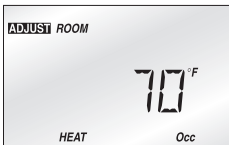

ROOM HEAT Occ

Desired temperature for heating during Occupied.

(Must have an active air sensor and be set to either Heat or Auto.)

35 to 100°F (1.5 to 38.0°C)

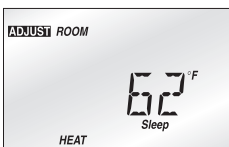

ROOM HEAT Sleep

Desired temperature for heating during Sleep.

(Must have an active air sensor and be set to either Heat or Auto.)

35 to 100°F (1.5 to 38.0°C)

Adjust Menu (2 of 4)



ROOM COOL Wake

Desired temperature for cooling during Wake.
(Must have an active air sensor and be set to either Cool or Auto.)
35 to 100°F (1.5 to 38.0°C)



ROOM COOL UnOcc

Desired temperature for cooling during UnOccupied.
(Must have an active air sensor and be set to either Cool or Auto.)
35 to 100°F (1.5 to 38.0°C)



ROOM COOL Occ

Desired temperature for cooling during Occupied.
(Must have an active air sensor and be set to either Cool or Auto.)
35 to 100°F (1.5 to 38.0°C)



ROOM COOL Sleep

Desired temperature for cooling during Sleep.
(Must have an active air sensor and be set to either Cool or Auto.)
35 to 100°F (1.5 to 38.0°C)



SLAB MINIMUM Wake

Minimum slab temperature during Wake.
(Must have an active slab sensor.)
OFF, 34 to 122°F (OFF, 1.0 to 50.0°C)



SLAB MINIMUM UnOcc

Minimum slab temperature during UnOccupied.
(Must have an active slab sensor.)
OFF, 34 to 122°F (OFF, 1.0 to 50.0°C)



SLAB MINIMUM Occ

Minimum slab temperature during Occupied.
(Must have an active slab sensor.)
OFF, 34 to 122°F (OFF, 1.0 to 50.0°C)



SLAB MINIMUM Sleep

Minimum slab temperature during Sleep.
(Must have an active slab sensor.)
OFF, 34 to 122°F (OFF, 1.0 to 50.0°C)

Adjust Menu (3 of 4)



SLAB MAXIMUM

Maximum slab temperature. This item is only available in the Installer access level. *(Must have an active slab sensor.)*

34 to 122°F, OFF (1.0 to 50.0°C, OFF)



SENSOR 1

Selects the type of auxiliary sensor present in the Sen 1 input. This item is only available in the Installer access level.

OFF, Indr, SLAB, REM



SENSOR 2

Selects the type of auxiliary sensor present in the Sen 2 input. This item is only available in the Installer access level.

OFF, Indr, SLAB, OUT



ROOM SENSOR

Selects whether the built-in sensor is functional or not. This item is only available in the Installer access level.

OFF, ON

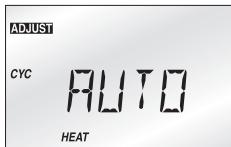

HEATING CYCLE

Determines the number of cycles per hour for the heating equipment. This item is only available in the Installer access level.

Auto, 2 to 12



COOLING CYCLE

Determines the number of cycles per hour for the cooling equipment. This item is only available in the Installer access level.

Auto, 2 to 12



COOLING INTERLOCK

Selects the time delay between the heating and cooling relays. This item is only available in the Installer access level.

10 to 180 min.



COOLING MINIMUM ON

Sets the minimum on time of the cooling contact. This is to prevent short cycling. This item is only available in the Installer access level.

0:30 to 5:00 min.

Adjust Menu (4 of 4)



COOLING MINIMUM OFF

Sets the minimum off time of the cooling contact. This is to prevent short cycling. This item is only available in the Installer access level.

0:30 to 10:00 min.



EARLY START

Selects whether or not the Early Start feature is active. This item is only available in the Installer access level.

OFF, ON



LITE

Sets the operation of the backlighting of the LCD.

ON, Tmpy ON, OFF



UNITS

The units of temperature used to display the items.

°F, °C

Error Messages (1 of 1)



E01

The thermostat was unable to read a piece of information stored in its memory. The thermostat was required to load the factory settings. The thermostat will stop operation until all settings are checked. To clear this error, select the Installer access level and check all of the settings in the Adjust and Schedule menus.



E02

There are no active sensors selected on the thermostat. Either the internal sensor must be turned on or at least one auxiliary sensor must be set to either INDR or SLAB. After the fault is corrected, press any button to clear the error message.

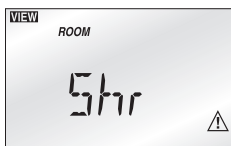

ROOM SHORT

The thermostat's internal air sensor is short circuit. This cannot be repaired in the field. The thermostat should be replaced or returned for repair.



ROOM OPEN

The thermostat's internal air sensor is open circuit. This cannot be repaired in the field. Either turn off the internal sensor and use an auxiliary sensor set to INDR or replace the thermostat. After the fault is corrected, press any button to clear the error message.

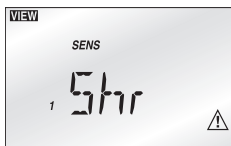

SENSOR 1 SHORT

The auxiliary sensor connected to the Sens 1 terminal is short circuit. Locate and repair the problem as described in the appropriate sensor brochure. After the fault is corrected, press any button to clear the error message.



SENSOR 1 OPEN

The auxiliary sensor connected to the Sens 1 terminal is open circuit. Locate and repair the problem as described in the appropriate sensor brochure. After the fault is corrected, press any button to clear the error message.

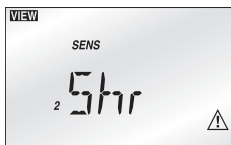

SENSOR 2 SHORT

The auxiliary sensor connected to the Sens 2 terminal is short circuit. Locate and repair the problem as described in the appropriate sensor brochure. After the fault is corrected, press any button to clear the error message.



SENSOR 2 OPEN

The auxiliary sensor connected to the Sens 2 terminal is open circuit. Locate and repair the problem as described in the appropriate sensor brochure. After the fault is corrected, press any button to clear the error message.

Installation

STEP ONE — GETTING READY

Check the contents of this package. If any of the contents are missing or damaged, please contact your wholesaler or tekmar sales representative for assistance.

Type 512 Includes: • One Programmable Thermostat 512 • Data Brochure D 512 • User Brochure U 512

STEP TWO — REMOVING THE FRONT COVER

Place a screwdriver or similar object into the small slot located in the top of the thermostat. Push the screwdriver against the plastic tab and pull the top of the front cover so that it pivots around the bottom edge of the base.

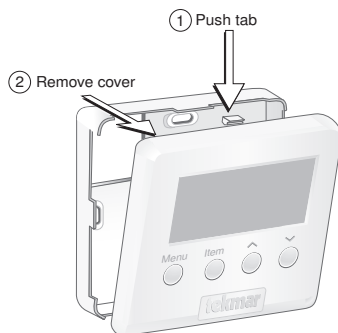

STEP THREE — MOUNTING THE BASE

The thermostat should be installed on an interior wall of the desired zone approximately 5' (1.5 m) above the floor. Do not mount the thermostat in a location that may be affected by localized heat sources or cold drafts. It may be necessary to install a draft barrier behind the thermostat to prevent air from blowing through the wiring hole and affecting the thermostat's built-in sensor.

Mount the base directly to the wall using two #6 1" screws. The screws are inserted through the mounting holes and must be securely fastened to the wall. If possible, at least one of the screws should enter a wall stud or similar surface. If the thermostat is to be mounted to a 2" x 4" electrical box, order an Adaptor Plate 007. This plate mounts to the electrical box and the thermostat mounts to the plate. Ensure that the electrical box does not provide cold air to the thermostat.

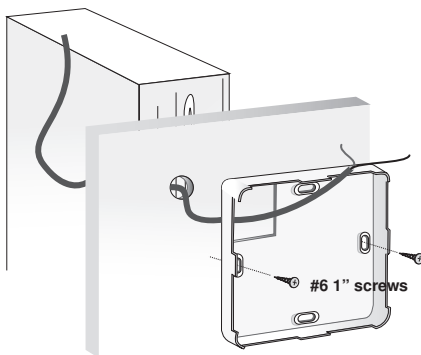

NOTE: If the thermostat is to be used for remote sensing (i.e. The built-in air sensor is disabled and an indoor sensor is being used.) Mount the thermostat in the desired location in an appropriate manner.

STEP FOUR ——— ROUGH IN WIRING

- 18 AWG or similar wire is recommended for all 24 V (ac) wiring.
- All wires are to be stripped to 1/4" (6 mm) to ensure proper connection to the control.
- Run wires from the 24 V (ac) power to the thermostat. Use a clean power source to ensure proper operation.
- If an auxiliary sensor is used, install the sensor according to the appropriate Data Brochure and run two wires from the sensor to the thermostat.
- Run wires from the heating device to the thermostat.

STEP FIVE ——— WIRING THE THERMOSTAT

(Refer to the examples on the following pages.)

24 V (ac) power

Connect the 24 V (ac) power to the R and C terminals (1 and 2) of the thermostat. This connection provides power to the microprocessor and display of the thermostat.

Auxiliary Sensors (S1 and S2)

Either an indoor, slab, or remote sensor may be connected to the S1 input. Connect the two wires from the auxiliary sensor to the Com and S1 terminals (3 and 4).

Either an indoor, slab, or outdoor sensor may be connected to the S2 input. Connect the two wires from the auxiliary sensor to the Com and S2 terminals (3 and 5).

Heat 1

The Heat terminals (6 and 7) are an isolated output. There is no power available on these terminals from the thermostat. These terminals are to be used as a switch for a 24 V (ac) circuit. This circuit can operate a low current 24 V (ac) device directly or an external relay to enable a line voltage or high current device.

Heat 2 / Cool

The Heat 2 / Cool terminals (8 and 9) are an isolated output. There is no power available on these terminals from the thermostat. This circuit can operate a low current 24 V (ac) device directly or an external relay to enable a line voltage or high current device.

STEP SIX ——— INSTALLING THE FRONT COVER

Align the hinges on the bottom of the front cover with the bottom of the thermostat mounting base. Pivot the front cover around the bottom hinges and push the top against the mounting base until it snaps firmly in place.

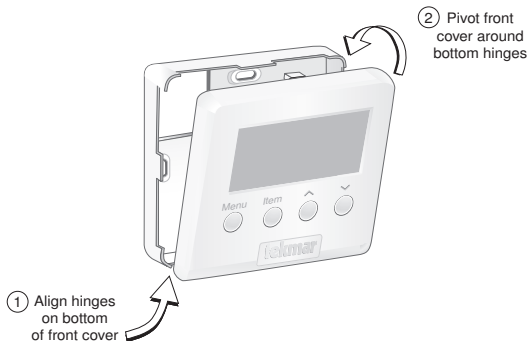

Wiring Examples

WIRING 24 V (AC) POWER AND AUXILIARY SENSORS

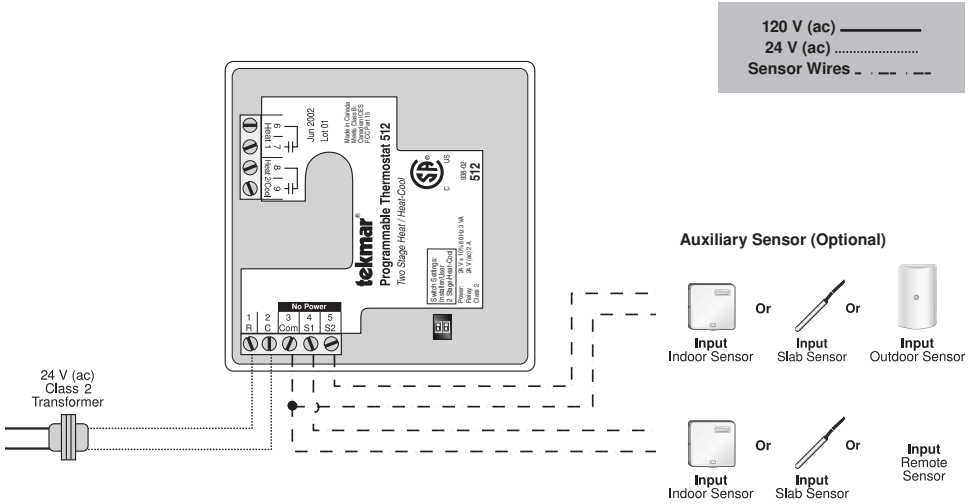

WIRING THE 512

One Stage with Zone Valve and Cooling

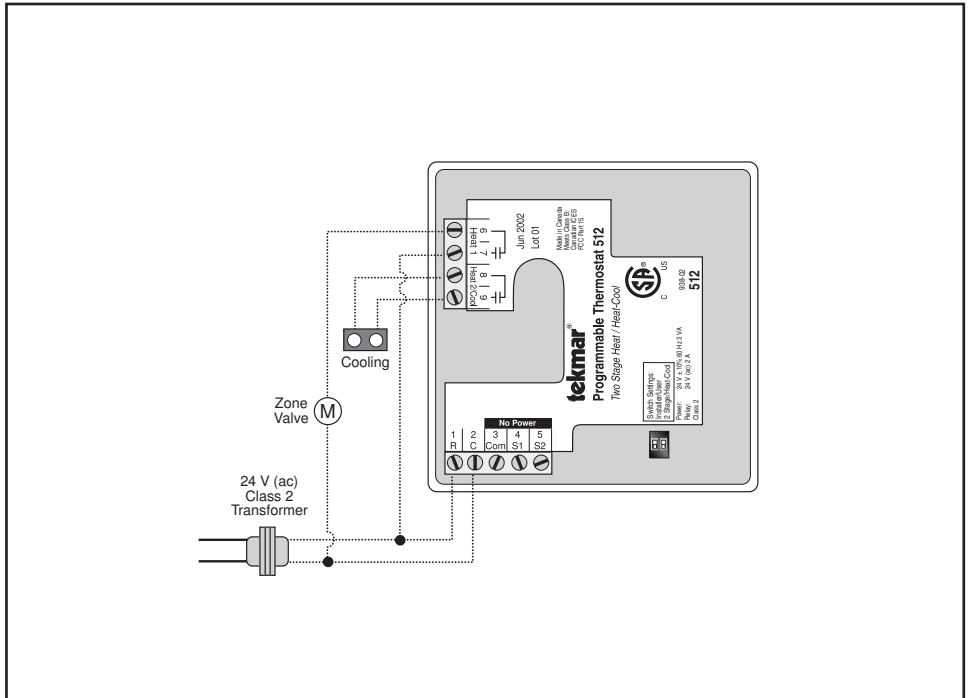

Two Stage with Zone Pump and Zone Valve

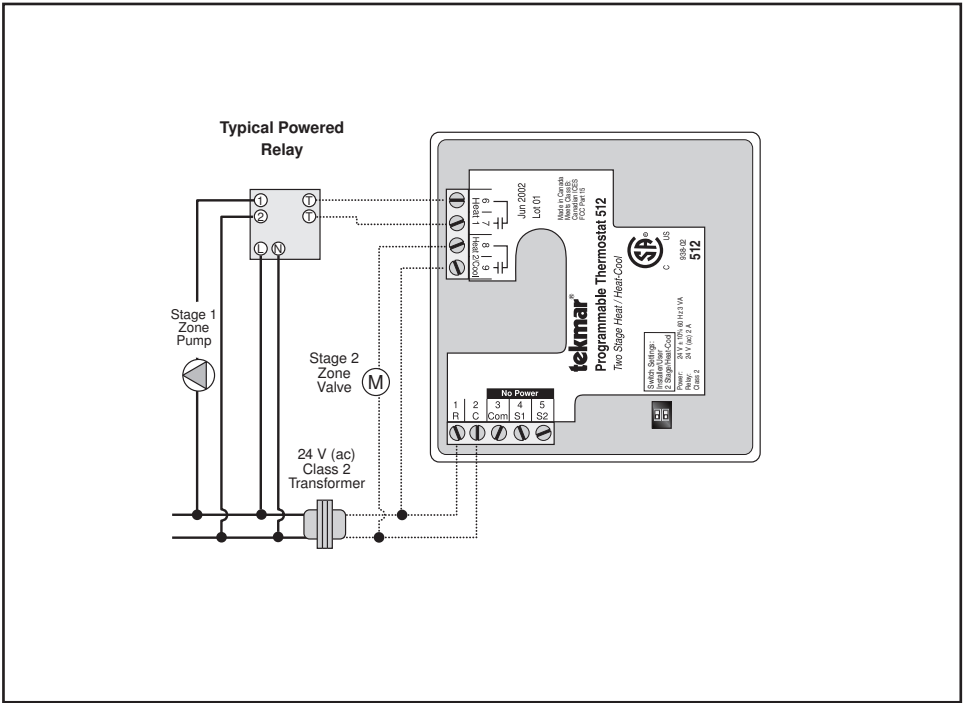

Two Stage with Zone Pump and Zone Valve

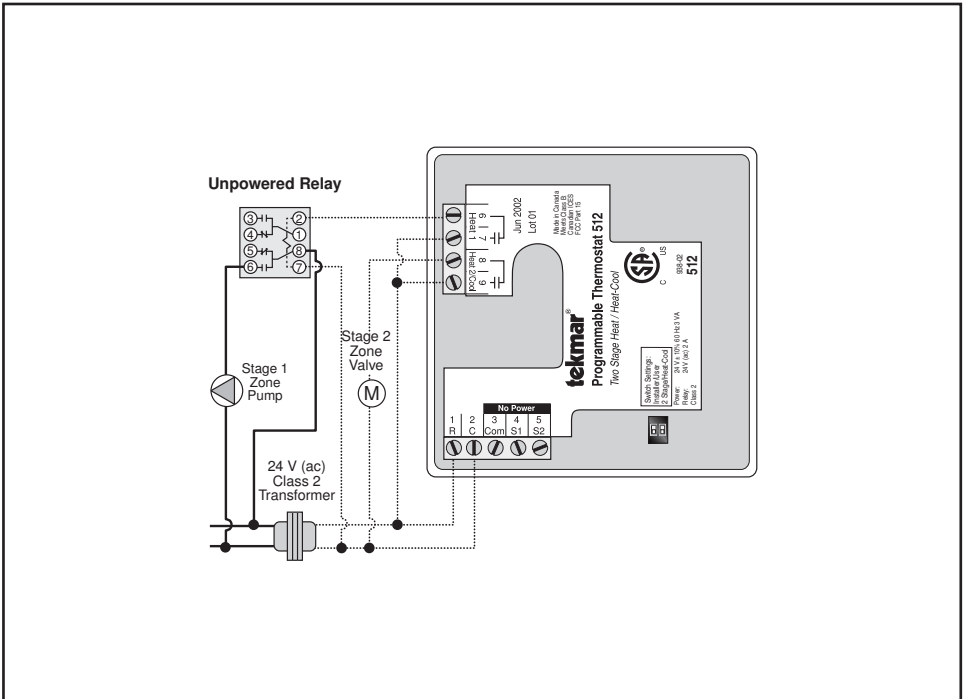

Two Stage with Zone Pumps

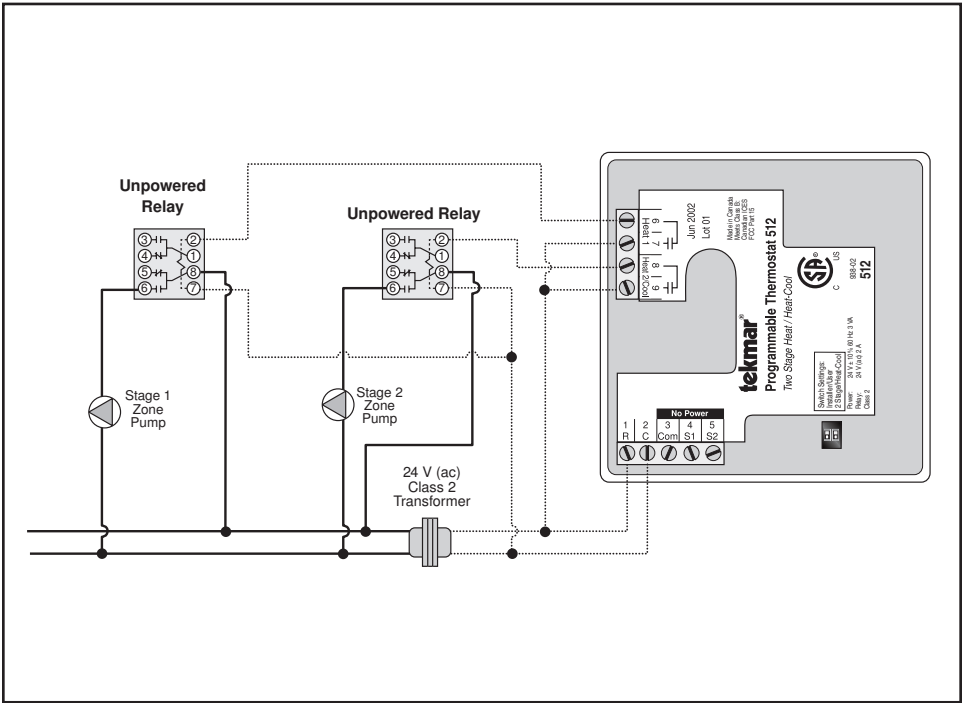

Two Stage with Zone Pumps

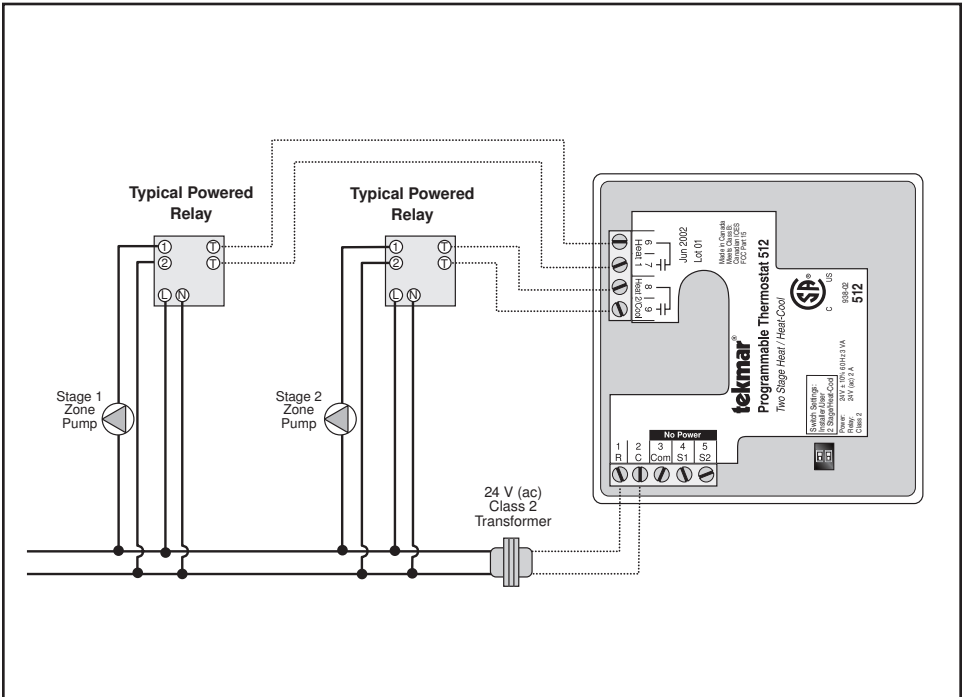

Technical Data

PROGRAMMABLE THERMOSTAT 512 *Two Stage Heat / Heat-Cool*

Literature	D 512, U 512
Control	Microprocessor PI control; This is not a safety (limit) control.
Packaged weight	0.46 lb. (210 g), Enclosure J, white PVC plastic
Dimensions	2-7/8" H x 2-7/8" W x 13/16" D (73 x 73 x 21 mm)
Approvals	CSA C US, CSA 22.2 N°24 and UL 873, meets class B: ICES & FCC Part 15.
Ambient conditions	Indoor use only, 32 to 122°F (0 to 50°C), < 90% RH non-condensing.
Power Supply	24 V (ac) ±10%, 60 Hz, 3 VA
Relay	24 V (ac) 2 A, Latching
Sensors	NTC thermistor, 10 kΩ @ 77°F (25°C ±0.2°C) β=3892
Included	None
Optional	tekmar type #: 070, 071, 072, 073, 076, 077, 078, 079.

Limited Warranty and Product Return Procedure

Limited Warranty *The liability of tekmar under this warranty is limited. The Purchaser, by taking receipt of any tekmar product ("Product"), acknowledges the terms of the Limited Warranty in effect at the time of such Product sale and acknowledges that it has read and understands same.*

The tekmar Limited Warranty to the Purchaser on the Products sold hereunder is a manufacturer's pass-through warranty which the Purchaser is authorized to pass through to its customers. Under the Limited Warranty, each tekmar Product is warranted against defects in workmanship and materials if the Product is installed and used in compliance with tekmar's instructions, ordinary wear and tear excepted. The pass-through warranty period is for a period of twenty-four (24) months from the production date if the Product is not installed during that period, or twelve (12) months from the documented date of installation if installed within twenty-four (24) months from the production date.

The liability of tekmar under the Limited Warranty shall be limited to, at tekmar's sole discretion: the cost of parts and labor provided by tekmar to repair defects in materials and / or workmanship of the defective product; or to the exchange of the defective product for a warranty replacement product; or to the granting of credit limited to the original cost of the defective product, and such repair, exchange or credit shall be the sole remedy available from tekmar, and, without limiting the foregoing in any way, tekmar is not responsible, in contract, tort or strict product liability, for any other losses, costs, expenses, inconveniences, or damages, whether direct, indirect, special, secondary, incidental or consequential, arising from ownership or use of the product, or from defects in workmanship or materials, including any liability for fundamental breach of contract.

The pass-through Limited Warranty applies only to those defective Products returned to tekmar during the warranty period. This Limited Warranty does not cover the cost of the parts or labor to remove or transport the defective Product, or to reinstall the repaired or replacement Product, all such costs and expenses being subject to Purchaser's agreement and warranty with its customers.

Any representations or warranties about the Products made by Purchaser to its customers which are different from or in excess of the tekmar Limited Warranty are the Purchaser's sole responsibility and obligation. Purchaser shall indemnify and hold tekmar harmless from and against any and all claims, liabilities and damages of any kind or nature which arise out of or are related to any such representations or warranties by Purchaser to its customers.

The pass-through Limited Warranty does not apply if the returned Product has been damaged by negligence by persons other than tekmar, accident, fire, Act of God, abuse or misuse; or has been damaged by modifications, alterations or attachments made subsequent to purchase which have not been authorized by tekmar; or if the Product was not installed in compliance with tekmar's instructions and / or the local codes and ordinances; or if due to defective installation of the Product; or if the Product was not used in compliance with tekmar's instructions.

THIS WARRANTY IS IN LIEU OF ALL OTHER WARRANTIES, EXPRESS OR IMPLIED, WHICH THE GOVERNING LAW ALLOWS PARTIES TO CONTRACTUALLY EXCLUDE, INCLUDING, WITHOUT LIMITATION, IMPLIED WARRANTIES OF MERCHANTABILITY AND FITNESS FOR A PARTICULAR PURPOSE, DURABILITY OR DESCRIPTION OF THE PRODUCT, ITS NON-INFRINGEMENT OF ANY RELEVANT PATENTS OR TRADEMARKS, AND ITS COMPLIANCE WITH OR NON-VIOLATION OF ANY APPLICABLE ENVIRONMENTAL, HEALTH OR SAFETY LEGISLATION; THE TERM OF ANY OTHER WARRANTY NOT HEREBY CONTRACTUALLY EXCLUDED IS LIMITED SUCH THAT IT SHALL NOT EXTEND BEYOND TWENTY-FOUR (24) MONTHS FROM THE PRODUCTION DATE, TO THE EXTENT THAT SUCH LIMITATION IS ALLOWED BY THE GOVERNING LAW.

Product Warranty Return Procedure All Products that are believed to have defects in workmanship or materials must be returned, together with a written description of the defect, to the tekmar Representative assigned to the territory in which such Product is located. If tekmar receives an inquiry from someone other than a tekmar Representative, including an inquiry from Purchaser (if not a tekmar Representative) or Purchaser's customers, regarding a potential warranty claim, tekmar's sole obligation shall be to provide the address and other contact information regarding the appropriate Representative.



tekmar Control Systems Ltd., Canada
tekmar Control Systems, Inc., U.S.A.
Head Office: 5100 Silver Star Road
Vernon, B.C. Canada V1B 3K4
(250) 545-7749 Fax. (250) 545-0650
Web Site: www.tekmarcontrols.com

Product design, software and literature
are Copyright © 2009 by:
tekmar Control Systems Ltd. and tekmar
Control Systems, Inc.

