

tekmar® - Data Brochure

Zone Control 369

D 369

01/09

The Zone Control 369 is designed to control the temperature in up to six heating zones using Room Temperature Units (RTUs) or indoor sensors. The 369 allows one stage heating zones, two stage heating zones, or a combination of one stage and two stage heating zones. PID zoning logic allows for staggering and synchronization of multiple zones in order to minimize boiler short cycling. The 369 is capable of operating a single cooling output and can provide automatic or manual heat / cool change over. When the 369 is used with a tekmar Reset or House Control, the 369 provides indoor temperature feedback that automatically adjusts the supply water temperature in order to satisfy the zone with the highest heat load. A large Liquid Crystal Display (LCD) is incorporated in order to view system status and operating information. The LCD and user key pad are used to set the control's adjustments and to monitor zone running times, outdoor high and low temperatures, minimum zone temperatures, and many other useful items.

Additional features include:

- Control Schedule
- Individual Zone Schedules
- Optimum Start / Stop
- Cooling Control or Cooling Enable
- Manual Override
- Slab Minimum and Slab Maximum Temperature Control
- Remote Display and Adjustment Capabilities
- Test Sequence to Ensure Proper Component Operation
- 115 V (ac) Power Supply
- CE and CSA C US Certified (approved to applicable UL standards)

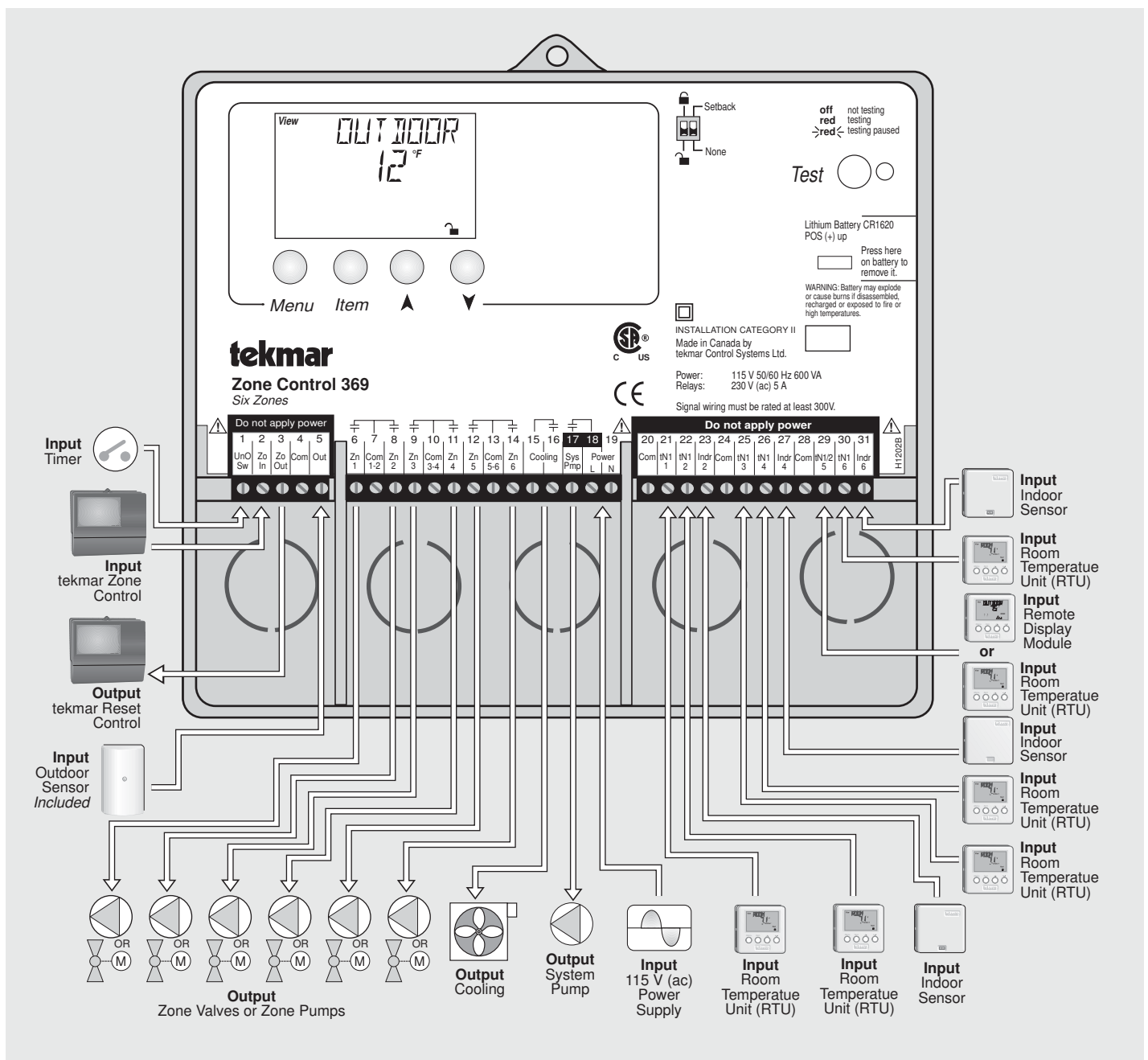

How To Use The Data Brochure

This brochure is organized into four main sections. They are: 1) *Sequence of Operation*, 2) *Installation*, 3) *Control Settings*, and 4) *Troubleshooting*. The Sequence of Operation has four subsections. We recommend reading each subsection of the *Sequence of Operation*, as each one contains important information on the overall operation of the control.

The *Control Settings* section (starting at the DIP Switch Settings) of this brochure describes the various items that are adjusted and displayed by the control. The control functions of each adjustable item are described in the *Sequence of Operation*.

Table of Contents

User Interface	Pg 2	Control Settings	Pg 18
Description of Display Elements	Pg 4	View Menu	Pg 18
Sequence of Operation	Pg 5	Adjust Menu	Pg 18
Section A: Heating	Pg 5	Monitor Menu	Pg 20
Section B: Cooling	Pg 7	Time Menu	Pg 21
Section C: Setback (UnOccupied)	Pg 9	Schedule Menu	Pg 22
Section D: tN 1 / 2 Devices	Pg 11	Miscellaneous Menu	Pg 23
Installation	Pg 12	RTU Menu	Pg 23
Electrical Connections	Pg 13	Testing and Troubleshooting	Pg 27
Testing the Wiring	Pg 15	Error Messages	Pg 29
DIP Switch Settings	Pg 17	Technical Data	Pg 32
Access Levels	Pg 17	Limited Warranty	Pg 32

User Interface

The 369 uses a Liquid Crystal Display (LCD) as the method of supplying information. You can use the LCD in order to setup and monitor the operation of your system. The 369 has four push buttons (Menu, Item, ▼, ▲) for selecting and adjusting settings. As you program your control, record your settings in the Adjust Menu table which is found in the second half of this brochure.

Menu

All of the items displayed by the control are organized into various menus. These menus are listed on the left hand side of the display (Menu Field). To select a menu, use the **Menu** button. By pressing and releasing the **Menu** button, the display will advance to the next available menu. Once a menu is selected, there will be a group of items that can be viewed within that menu.

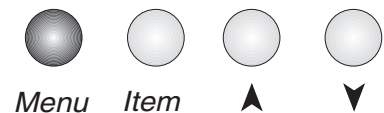

Item

The abbreviated name of the selected item will be displayed in the item field of the display. To view the next available item, press and release the **Item** button. Once you have reached the last available item in a menu, pressing and releasing the **Item** button will return the display to the first item in the selected menu.

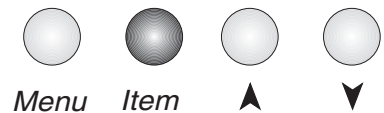

Adjust

To make an adjustment to a setting in the control, begin by selecting the appropriate menu using the **Menu** button. Then select the desired item using the **Item** button. Finally, use the ▼ and / or ▲ button to make the adjustment.

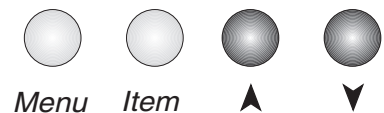

Additional information can be gained by observing the Status field of the LCD. The status field will indicate which of the control's outputs are currently active. Most symbols in the status field are only visible when the View Menu is selected.

MENU FIELD

The 369 has a number of menus used to monitor system status and adjust settings in the control. The current menu will be displayed in the left hand side of the display.

View Menu

The View menu is used to view the outdoor temperature and zone temperatures.



Adjust Menu

There are seven separate menus used to make adjustments to the control settings and the zone settings. There is an Adjust menu for the control, and an Adjust menu for each zone.

Control Adjust Menu

The Control Adjust menu is used to make adjustments to the control settings. The control settings affect every zone. To access the control settings, select the Adjust menu by using the **Menu** button. *Adjust* will be displayed in the left hand side of the display.



Zone Adjust Menu

The Zone Adjust menu is used to make adjustments to the zone settings. There is a Zone Adjust menu for each zone that an RTU or indoor sensor is connected to. To access the zone settings for a particular zone, select the Zone Adjust menu for that zone by using the **Menu** button. *Adjust* will be displayed in the left hand side of the display, and *Zone* followed by the zone number will be displayed in the bottom of the display.

Note: The Zone Adjust menu in the control is different than the Adjust menu in a display RTU.

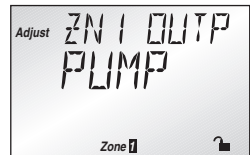

Monitor Menu

The Monitor menu is used to monitor the system over a period of time. It is possible to track system pump and zone running hours, and high and low zone temperatures.

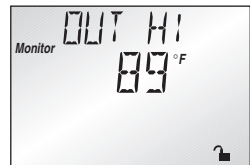

Time Menu

The Time menu is used for setback purposes, and displays the time of day and the day of the week. In order to access the Time menu, the *Setback / None* DIP switch must be in the *Setback* position. Refer to the Settings section on how to set the clock.



Schedule (Schd) Menu

The Schd menu is used to set the control schedules. In order to access the control schedules in the Schd menu, the *Setback / None* DIP switch must be in the *Setback* position. Schedule overrides are also available in the Schd menu. Refer to the Settings section on how to set a schedule.



Miscellaneous (Misc) Menu

The Misc menu is used to select units, access levels, and backlite operation.

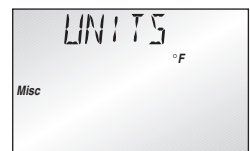

Display

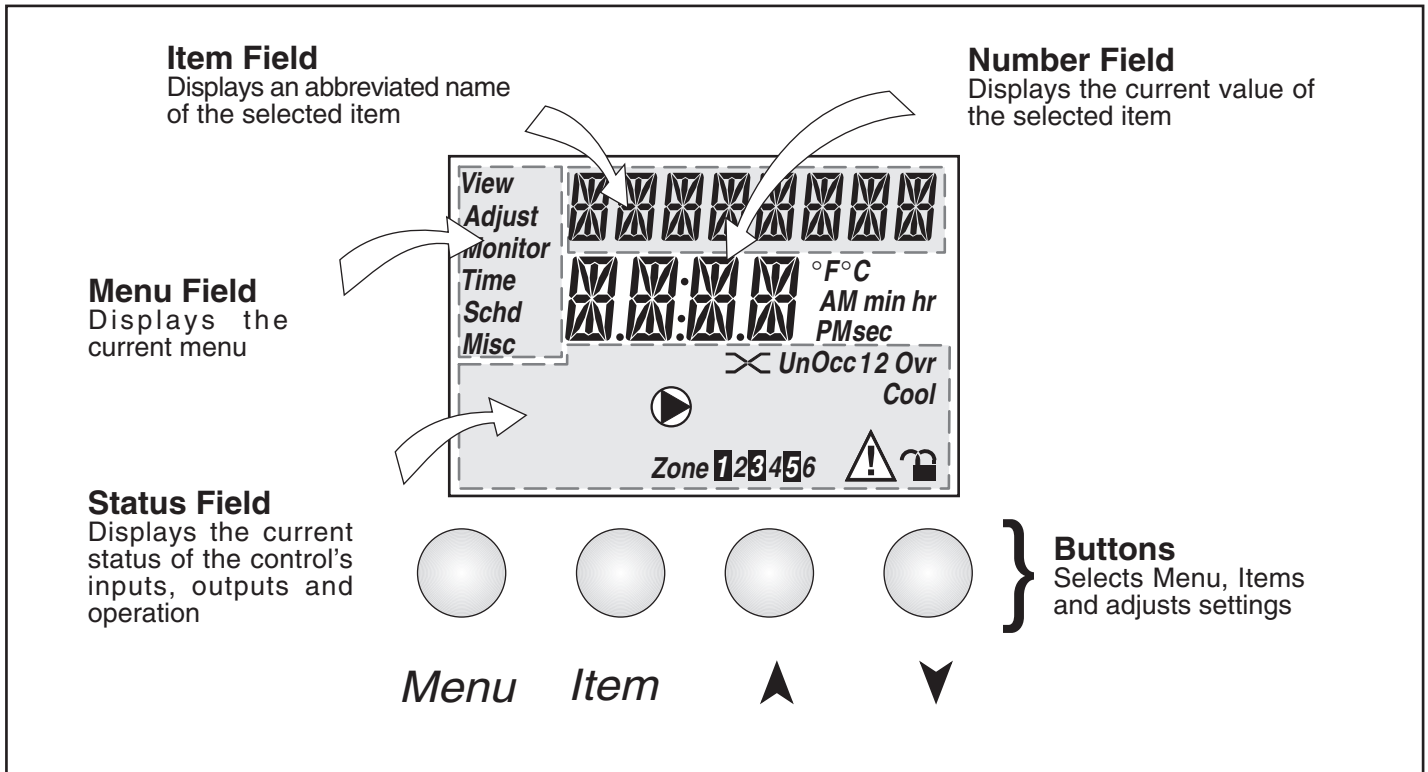

Symbol Description

	Pump Displays when the system pump is in operation.	<i>Ovr</i>	Override Displays when the control is in override mode.
<i>Zone</i> 1 2 3 4 5 6	Zone Displays when a zone is in operation.	<i>Cool</i>	Cooling Displays when the <i>Cooling</i> relay is on.
	Optimum Stop Displays when a zone is in optimum stop.		Warning Displays when an error exists or when a limit has been reached.
	Optimum Start Displays when a zone is in optimum start.		Lock/UnLock Displays whether control is locked or unlocked.
<i>UnOcc</i>	Unoccupied Schedule Displays when the control is in unoccupied (Night) mode.	°F, °C	Temperature Displays the unit of measure that all of the temperatures are to be displayed.
<i>Occ</i>	Occupied Schedule Displays when the control is in occupied (Day) mode.	<i>AM, PM, sec, min, hr</i>	Time Displays the unit of measure that all of the times are to be displayed.

Definitions

The following defined terms and symbols are used throughout this manual to bring attention to the presence of hazards of various risk levels, or to important information concerning the life of the product.



- Warning Symbol: Indicates presence of hazards which can cause severe personal injury, death or substantial property damage if ignored.



- Double insulated

**INSTALLATION
CATAGORY II**

- Local level, appliances.

Sequence of Operation

Section A
Heating Operation
Page 5 - 7

Section B
Cooling Operation
Page 7 - 8

Section C
Setback
(UnOccupied)
Page 9 - 10

Section D
tN 1/2 Devices
Page 11

Section A1: General Heating

POWERING UP THE CONTROL

When the Zone Control 369 is powered up, the control displays the control type number in the LCD for 2 seconds. Next, the software version is displayed for 2 seconds. Finally, the control enters into the normal operating mode and the LCD defaults to displaying the current outdoor temperature.

ZONING OPERATION

The 369 can directly control the temperature in up to six one stage heating zones, three two stage heating zones, or a combination of one stage and two stage heating zones. In order to measure the indoor temperature, each zone requires either an indoor sensor or an RTU. With display RTUs, the desired zone temperature is set using the HEATING adjustment in the Adjust menu of the RTU. With non-display RTUs, the desired zone temperature is set using the RTU dial. If an indoor sensor is used, the desired zone temperature is set using the HEATING adjustment in the Zone Adjust menu of the control.

HEATING CYCLE (HEAT CYC)

The 369 operation is based on a cycle length which is adjustable through the HEAT CYC setting in the Control Adjust menu of the control. During every cycle, the control turns on each zone relay for a specific on time. The required on time is calculated based on the PID response of the zone during the previous cycle period. If the zone requires more heat, the on time is increased, and if the zone requires less heat, the on time is reduced. In order to prevent short cycling, the 369 ensures that the zone relays remain on or off for a minimum amount of time.

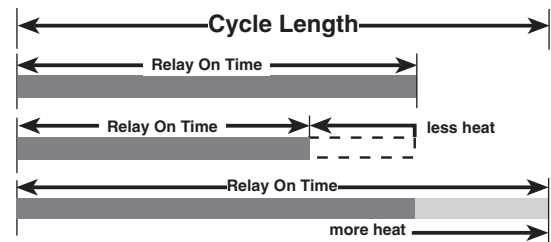

PID Zoning Logic

Proportional (P)

Proportional control logic compares the actual zone temperature to the desired zone temperature. Zone relay on time is based on the difference between the actual temperature and the desired temperature. As the zone temperature drops, the relay on time increases, and as the zone temperature rises, the relay on time decreases.

Integral (I)

Integral control logic compares the actual zone temperature to the desired zone temperature over a period of time. The longer the actual temperature is below the desired temperature, the longer the on time for the zone relay will be.

Derivative (D)

Determines how fast or how slow the actual temperature is changing.

P + I + D = PID

If proportional, integral and derivative (PID) control logic is used, the control is more able to prevent excessive temperature swings and provide a stable room temperature under all conditions. It not only takes into account how much the room temperature has dropped, but also how long there has been a droop and how fast the temperature is changing.

ZONE CONTROL LOAD STAGGERING AND SYNCHRONIZATION

The 369 staggers the operation of the zones in order to achieve a steady load on the boiler while preventing boiler short cycling. Multiple Zone Controls can be daisy chained together to increase the number of zones. Each of the Zone Controls synchronizes its zone operating cycles based on the *Zo In* input from the other Zone Controls. This results in a more stable system flow rate and improved boiler operation. In order for Zone Control synchronization to work properly, the cycle length on each Zone Control must be equal.

Note: If a Zone Control 367/ 368 or House Control 370 / 371 is used with a Zone Control 369, the HEAT CYC adjustment in the 369 should be set to 15 minutes.

ZONE CONTROL OPERATION WITH A TEKMAR OUTDOOR RESET CONTROL

The 369 can provide indoor temperature feedback to a tekmar Reset Control. When multiple Zone Controls are used, each zone control uses its *Zo Out* output to sequentially pass the information to the tekmar Reset Control. The ZO OUT item displayed in the view menu represents the target from the zone with the highest heat requirement. The tekmar Reset Control uses this target to determine the water temperature required to satisfy the zone with the highest heat requirement.

ZONE OUTPUT (ZN OUTP)

The ZN OUTP adjustment in the Zone Adjust menu of the control selects the zoning device used for each zone, and affects the operation of the system pump.

When PUMP is selected, the control assumes the device used to control the heat delivery is a pump. When the zone turns on, the control does not operate the system pump.

When VLV is selected, the control assumes the device used to control the heat delivery is a fast acting spring return valve. When the zone turns on, the control turns on the system pump.

When THRM is selected, the control assumes the device used to control the heat delivery is a slow acting zone valve with a thermal actuating motor. When the zone turns on, the system pump is held off for a period of time to allow the thermal motor zone valve to fully open. This time is adjustable through the thermal open (THRM OPEN) setting in the Control Adjust menu of the control. The thermal close (THRM CLS) setting in the Control Adjust menu of the control sets the time required for the thermal motor zone valve to close.

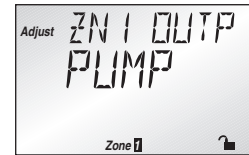

SYSTEM PUMP OPERATION

The system pump (*Sys Pmp*) contact is operated based on the zoning device(s) selected. Refer to the ZONE OUTPUT section for system pump operation. The system pump is also operated based on the purge and exercise functions.

EXERCISING (EXERCISE)

The 369 has a built-in exercising function. The exercising period is adjustable and comes factory set at 70 hours. If the zoning devices or the system pump has not been operated at least once during every exercising period, the control turns on the output for 10 seconds. This minimizes the possibility of a pump or valve seizing during a long period of inactivity. The Test LED flashes anytime the control is exercising.

Note: The zone relay exercising time is increased to the THRM OPEN setting if THRM is selected as the zoning device.

PURGING (PURGE)

The 369 includes a purging function which allows for any excess heat available in the boiler to be purged into the zones. The 369 removes the call for heat from the reset control some time before the zones are turned off. The purging time is adjustable based on the PURGE setting in the Control Adjust menu of the control.

Section A2: One Stage Heating

ONE STAGE HEATING

A one stage heating zone has one RTU or indoor sensor controlling a single heating terminal. One RTU or indoor sensor therefore controls one output relay. If an RTU is used to control a one stage heating zone, the RTU must be connected to a *tN1* terminal. If an RTU is connected to an even numbered *tN1* terminal (i.e. *tN1 2*, *tN1 4* or *tN1 6*), ONE must be selected through the STG NUM adjustment in the Zone Adjust menu of the control. If an indoor sensor is used to control a one stage heating zone, the sensor can only be connected to an *Indr* terminal (i.e. *Indr 2*, *Indr 4* or *Indr 6*), and ONE must be selected through the STG NUM adjustment in the Zone Adjust menu of the control.

Example: An RTU connected between *Com* and *tN1 1* terminals (20 and 21) is used to control the output relay *Zn 1*, and an RTU connected between *Com* and *tN1 2* terminals (20 and 22) is used to control the output relay *Zn 2*.

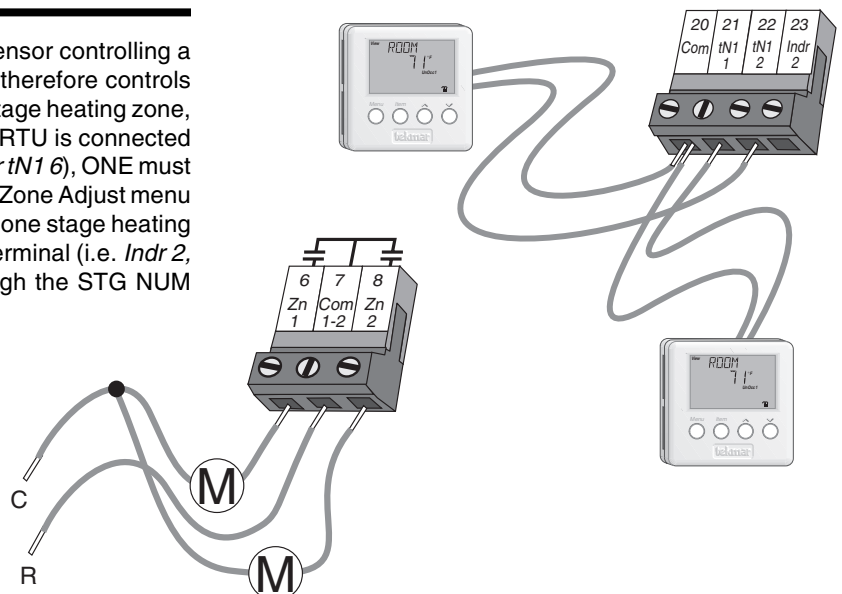

Section A3: Two Stage Heating

TWO STAGE HEATING

In cases where a one stage heating system can not provide sufficient heat, a second stage of heat from an additional heating terminal can be provided to supplement the first stage. A two stage heating system therefore has one RTU or indoor sensor controlling two output relays: a *Lo stage* relay and a *Hi stage* relay. If an RTU is used to control a two stage heating zone, the RTU must be connected to an even *tN1* terminal (i.e. *tN1 2*, *tN1 4* or *tN1 6*), and TWO must be selected through the STG NUM adjustment in the Zone Adjust menu of the control. If an indoor sensor is used to control a two stage heating zone, the sensor must be connected to an *Indr* terminal (i.e. *Indr 2*, *Indr 4* or *Indr 6*), and TWO must be selected through the STG NUM adjustment in the Zone Adjust menu of the control. The odd numbered zone relay becomes the Lo Stage and the even numbered zone relay becomes the Hi Stage.

Example: An RTU connected between *Com* and *tN1 2* terminals (20 and 22) is used to control the output relays *Zn 1* and *Zn 2*. Relay *Zn 1* is the *Lo stage* output relay and relay *Zn 2* is the *Hi stage* output relay.

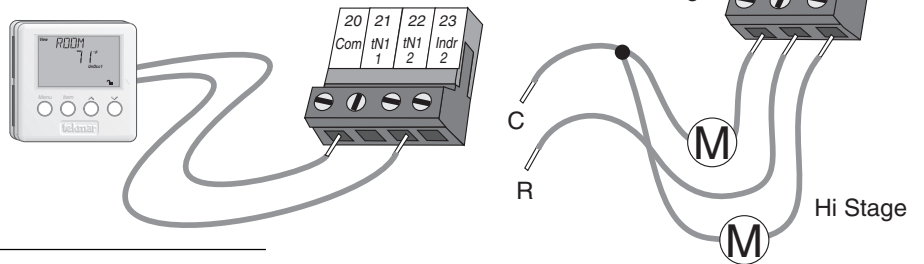

PID Staging Logic

The temperature within each two stage zone is controlled by varying the on time of the output relays over a cycle length. During light loads, the 369 cycles the *Lo Stage* relay on and off. As the load increases, the *Lo stage* relay on time increases until it reaches the maximum of the cycle length. The *Hi stage* relay is then turned on and its on time is increased as the load increases. When the heating load decreases again, the on time of the *Hi stage* relay is reduced until the *Hi stage* relay is turned off completely. The control then starts to reduce the on time of the *Lo stage* relay.

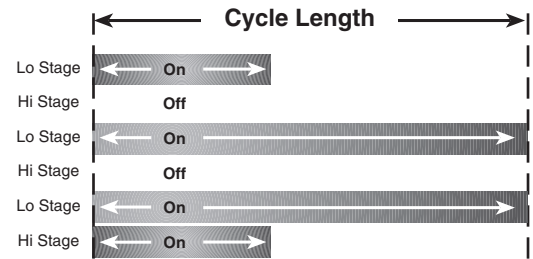

Section B: Cooling Operation

Section B1
General Cooling

Section B2
Cooling Enable

Section B3
Cooling Control

Section B1: General Cooling

GENERAL COOLING

The Zone Control 369 is capable of operating a single cooling group to provide either cooling enable (ENBL) or cooling control (CTRL). This is an adjustable item through the COOL MOD setting in the Control Adjust menu of the control. In order to prevent short cycling of the mechanical cooling unit, the 369 ensures the *Cooling* relay is operated for a minimum amount of time. The minimum run time (MIN RUN) and minimum off time (MIN OFF) are adjustable settings in the Control Adjust menu of the control.



COOLING GROUP (CG)

A cooling group is a group of heating zones that are a part of a cooling zone. This function allows zones which are assigned to the cooling group to be doing cooling, while zones which are not assigned to the cooling group are heating. A heating zone can be assigned to the cooling group by selecting CG through the ZN COOL adjustment in the Zone Adjust menu of the control. Zone 6 (*tN1 6* or *Indr 6*) is always a member of the cooling group; therefore, there is no option for removing this zone from the cooling group.



COOLING INTERLOCK (INTRLOCK)

In order to prevent simultaneous heating and cooling, the 369 provides a cooling interlock. Once all the heating zones assigned to the cooling group have been satisfied for a period of time, the control will allow cooling operation to occur. This time is adjustable through the INTRLOCK setting in the Control Adjust menu of the control. Once any zone assigned to the cooling group requires heat, cooling operation is terminated.

HEAT / COOL CHANGEOVER

The changeover between heating and cooling is based on whether or not a display RTU is connected to zone 6 (*tN1 6*). If a display RTU is connected to zone 6 (*tN1 6*), the changeover between heating and cooling is selected at RTU 6. A pointer in the lower right hand display of the RTU indicates that this RTU is the designated heat / cool RTU. Heat / cool changeover can be achieved automatically or manually through the RTU. The MODE adjustment in the Adjust menu of RTU 6 allows the selection between HEAT, COOL, AUTO or OFF. When HEAT is selected at RTU 6, the cooling system is locked out and only heating is allowed as required. When COOL is selected at RTU 6, the heating system is locked out and all the heating zones assigned to the cooling group shut off. Cooling is then allowed to operate as required. When AUTO is selected at RTU 6, the changeover between heating and cooling occurs based on the Cooling Interlock function. Cooling is then allowed to operate as required. When OFF is selected at RTU 6, zone 6 becomes inactive and cooling operation is disabled. If a display RTU is not connected to zone 6 (*tN1 6*), the changeover between heating and cooling is automatic.

COOLING WHILE FLOOR WARMING

The 369 can use a 063 display RTU to provide floor (slab) and air temperature control. The 063 RTU has a built-in air sensor which is used to control the heating and cooling air temperature, while a slab sensor connected to the 063 RTU controls the floor (slab) temperature. During mild conditions the floor (slab) is maintained at a minimum temperature, and as the outdoor temperature drops the floor (slab) will rise above the minimum setting and the air sensor takes over. As the outdoor temperature rises and cooling is required, the control targets the cooling setpoint and the floor (slab) is still maintained at a minimum temperature.

Note: During mild conditions, it is possible to overheat the space if the floor (slab) is maintained at a minimum temperature.

Section B2: Cooling Enable

COOLING ENABLE (ENBL)

The *Cooling* relay can be used to enable a cooling system, which can be controlled by a cooling thermostat. The changeover between heating and cooling is described in the Heat / Cool Changeover section.

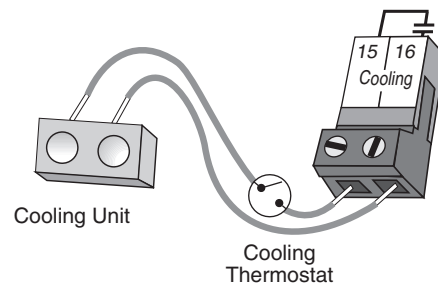

Section B3: Cooling Control

COOLING CONTROL (CTRL)

A display RTU connected to zone 6 (*tN1 6*) can be used to control a heating zone as well as the cooling system. This RTU is designated as the controlling device for the cooling system. The actual cooling “room” temperature is an average of the room temperature of all the zones assigned to the cooling group. The desired cooling temperature is set using the COOLING adjustment in the Adjust menu of RTU 6. When cooling, the 369 varies the on time of the *Cooling* relay based on a cycle length. The cooling cycle length is adjustable through the COOL CYC setting in the Control Adjust menu of the control. If COOL CYC is set to AUTO, the control automatically calculates a cooling cycle length. During every cycle, the control turns on the *Cooling* relay for a specific on time. The required on time is calculated based on the PID response of the cooling group during the previous cycle period. If the cooling group requires more cooling, the on time is increased, and if the cooling group requires less cooling, the on time is reduced. The changeover between heating and cooling is described in the Heat / Cool Changeover section.

Note: If a non-display RTU is connected to *tN1 6* or if an indoor sensor is connected to *Indr 6*, cooling control (CTRL) can not be selected.

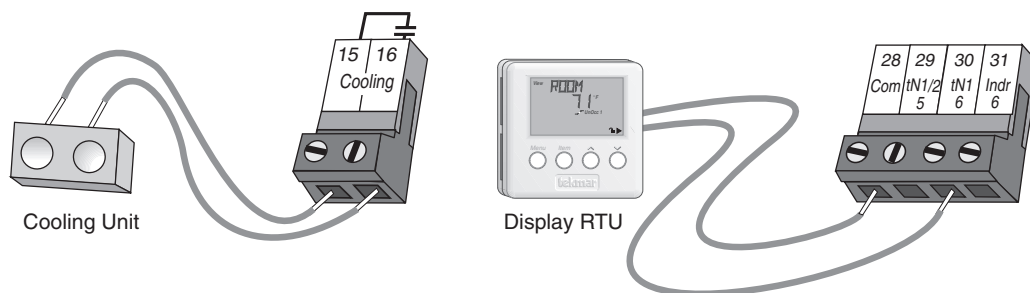

Section C: UnOccupied

SETBACK (UNOCCUPIED)

To provide greater energy savings, the 369 can lower the building temperature at night or when the building is unoccupied. The 369 has a built-in clock which allows for heating and cooling setback capabilities. As an option, an external timer may be connected to provide a separate setback signal. When in the unoccupied mode, the *UnOcc* segment is displayed in the appropriate LCD. The 369 operates the zones based on the *UnOcc* settings made in the control and / or display RTUs. With display RTUs, the desired zone temperature is set using the HEATING *UnOcc* adjustment in the Adjust menu of the RTU. With non-display RTUs or indoor sensors, the desired zone temperature is set using the HEATING *UnOcc* adjustment in the Zone Adjust menu of the control. If cooling control (CTRL) is selected, the desired cooling temperature is set using the COOLING *UnOcc* adjustment in the Adjust menu of RTU 6. The setback feature is enabled by setting the *Setback / None* DIP switch to the *Setback* position, and selecting a desirable schedule. As well, a schedule override or an external unoccupied override can enable the setback feature.

Clock

The clock in the 369 is used for setback purposes. In order to set the clock, the *Setback / None* DIP switch must be in the *Setback* position. The clock is accessed in the Time menu of the control. The clock displays the time of day and the day of the week. Setting of the clock is described in the Settings section of this brochure.

SCHEDULE

The 369 provides a control schedule and a zone schedule. Non-display RTUs and indoor sensors may only select the control schedule, while display RTUs have the option to select either the control schedule or its own zone schedule. Each schedule allows two occupied and two unoccupied events each day. During the first event, the 1 segment is displayed in the appropriate LCD, and during the second event, the 2 segment is displayed. Setting of a schedule is described in the Settings section of this brochure.

Zone Schedule (ZONE)

The zone schedule allows each zone to have its own independent schedule. A zone schedule is only available for zones using display RTUs. The ZONE schedule is accessed through the HEAT SCHD adjustment in the schedule (Schd) menu of the RTU.



Control Schedule (CTRL)

The control schedule allows each zone to be on the same schedule. When using display RTUs, the CTRL schedule is accessed through the HEAT SCH adjustment in the schedule (Schd) menu of the RTU. When using non-display RTUs or indoor sensors, the CTRL schedule is accessed through the HT SCHD adjustment in the Zone Adjust menu of the control.

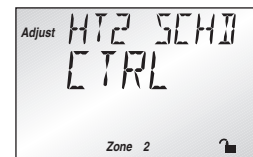

Cooling Schedule

The 369 allows the heat / cool RTU (*tN1 6*) to select a schedule for cooling. The COOL SCH adjustment in the schedule (Schd) menu of the RTU may be set to CTRL to use the control schedule, or ZONE to use the zone schedule.

Note: If cooling enable (ENBL) is selected and the control is in unoccupied mode, the control does not operate the *Cooling* relay.

OPTIMUM START / STOP

The Optimum Start / Stop feature is used during transitions between the unoccupied mode and the occupied mode. If Optimum Stop is selected, the control turns off the zone valve or pump before the start of the setback period. Therefore, the zone starts to cool down at the beginning of the UnOccupied period. If Optimum Start is selected, the 369 raises the zone temperature during the final stages of the unoccupied period. This ensures the zone is at the occupied temperature as soon as the occupied period begins.

The Optimum Start / Stop function may be selected for each zone to provide optimum start (STRT), optimum stop (STOP), or optimum start and stop (BOTH). For display RTUs this setting is selected through the OPT STRT adjustment in the schedule (Schd) menu of the RTU. For non-display RTUs or indoor sensors, the Optimum Start / Stop setting is selected through the HEAT OPT adjustment in the Zone Adjust menu of the control.

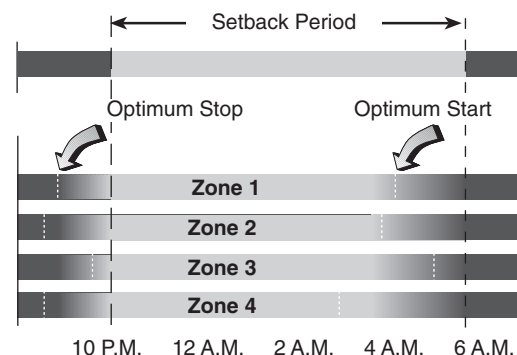

If cooling control (CTRL) is selected, Optimum Start may be selected for cooling. If Optimum Start is selected, the control operates the *Cooling* relay to ensure the cooling group is at the occupied temperature as soon as the occupied period begins. This function is enabled by selecting STRT through the COOL OPT adjustment in the Control Adjust menu of the control.

SCHEDULE OVERRIDES

The 369 has a number of setback overrides that are selected through the schedule (Schd) menu. A system override and a zone override are available. Any time an override is in effect, the *Ovr* segment is displayed in the appropriate LCD.

System Override (OVERRIDE)

The system overrides affect every zone and are selected in the schedule (Schd) menu of the control, remote display module (RDM), or display RTU. These setback overrides have priority over any external setback signal.

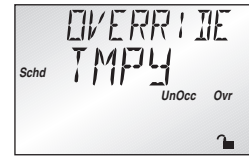

Zone Override (ZONE OVR)

Zone overrides are only available for zones using display RTUs. The zone overrides only affect the respective zone, and are selected in the schedule (Schd) menu of the RTU or remote display module (RDM).

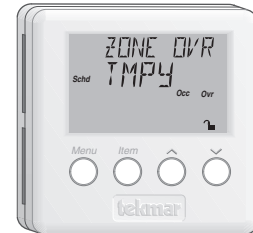

Temporary (TMPY)

If a temporary occupied or temporary unoccupied override is selected, the 369 operates the zone(s) in the selected override mode for 3 hours from the time the selection is made. Once completed, the control reverts to the currently scheduled operation.

Permanent (PERM)

If a permanent occupied or permanent unoccupied override is selected, the 369 operates the zone(s) in the selected override mode until a new override is selected.

Away (AWAY)

If the AWAY override is selected, the 369 reduces all the heating setpoints to a maximum of 62°F (17°C), and increases the cooling setpoint to at least 82°F (28°C). Also, slab minimum settings and all existing schedules are ignored.

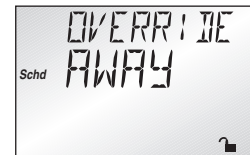

External UnOccupied Override

An external signal can place the 369 into unoccupied mode. Any time the *UnO Sw* (1) and the *Com* (4) terminals are shorted together, the control overrides the occupied mode and operates in the unoccupied mode. The *UnOcc Ovr* segment is displayed in the appropriate LCD. The control remains in the unoccupied mode as long as the signal is present or until a system override is selected.

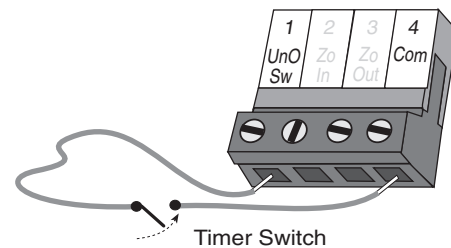

Section D: tekmar Net 1/2 Devices

TEKMAR ROOM TEMPERATURE UNIT (RTU) 060

This RTU consists of an air temperature sensor, a dial, an LED and a push button. The dial is used to set the desired occupied room temperature. The push button is used to select either a permanent unoccupied override or a temporary occupied override. Once the push button is pressed and released, a red LED is activated to indicate a permanent unoccupied override. Once the push button is pressed and held for at least one second, a green LED is activated to indicate a temporary occupied override.



TEKMAR ROOM TEMPERATURE UNIT (RTU) 062

This RTU consists of an air temperature sensor, a liquid crystal display (LCD) and four buttons. These buttons and the LCD are used to set and view the desired room temperature, and for setback overrides. The RTU's LCD displays the current room temperature, the outdoor air temperature and a number of other items.

In cases where a restricted temperature range is required, the RTU's range can be limited by changing the access level of the RTU.

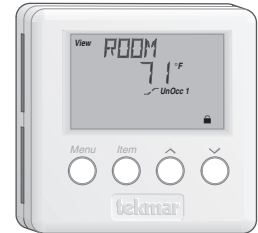

TEKMAR ROOM TEMPERATURE UNIT (RTU) 063

This RTU consists of one internal air sensor, three remote temperature sensor inputs, a liquid crystal display (LCD) and four buttons. These buttons and the LCD are used to set and view the desired room temperature, and for setback overrides. The RTU's LCD displays the current room temperature, the outdoor air temperature, temperature at the slab sensor, and a number of other items. In cases where a restricted temperature range is required, the RTU's range can be limited by changing the access level of the RTU.

Remote indoor sensors can be connected to the 063 to average the air temperature reading. Typically, multiple remote sensors are used in large open areas in a building to get an average indoor air temperature. Any type of tekmar 10K sensor can be connected to the input(s) on the 063.

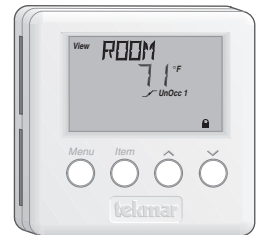

Room or Slab Temperature Control using a Floor (Slab) Sensor

The RTU 063 can be configured for floor (slab) and air temperature control using a floor (slab) sensor connected to the *Rs3* and *Com* terminals (3 & 5) and the air sensor in the RTU. The minimum and maximum floor (slab) temperature and air temperature settings are adjusted at the RTU. The minimum and maximum slab setpoints have priority over the air temperature setpoint. Once the slab setpoint(s) have been satisfied, the air temperature setpoint can then be satisfied.

If the air temperature sensor at the RTU is turned off, the air temperature is ignored.

TEKMAR REMOTE DISPLAY MODULE (RDM) 040

This module provides the user with a remote interface to the 369. The RDM can be used to remotely monitor and adjust settings on the control and display RTUs. The RDM can display any of the system and status indicators visible on the control and display RTU. It also has a built in alarm contact that can be used to trigger an external alarm if either a control or sensor error occurs, or if a limit has been reached.

To access the control's user interface, select CTRL through the DEVICE item in the *Misc* menu. To access a display RTU's user interface, select RTU*i* (where *i* corresponds to the appropriate zone) through the DEVICE item in the *Misc* menu.



Installation

CAUTION

Improper installation and operation of this control could result in damage to the equipment and possibly even personal injury. It is your responsibility to ensure that this control is safely installed according to all applicable codes and standards. This electronic control is not intended for use as a primary limit control. Other controls that are intended and certified as safety limits must be placed into the control circuit. Do not open control. Refer to qualified personnel for servicing. Opening voids warranty and could result in damage to the equipment and possibly even personal injury.

STEP ONE — GETTING READY

Check the contents of this package. If any of the contents listed are missing or damaged, please contact your wholesaler or tekmar sales representative for assistance.

Type 369 includes: One Zone Control 369, One Outdoor Sensor 070, Data Brochures D 369, D 070, D 001, Application Brochure A 369, User Brochure U 369.

Note: Carefully read the details of the *Sequence of Operation* to ensure that you have chosen the proper control for your application.

STEP TWO — MOUNTING THE BASE

Remove the control from its base by pressing down on the release clip in the wiring chamber and sliding the control away from it. The base is then mounted in accordance with the instructions in the Data Brochure D 001.

STEP THREE — ROUGH-IN WIRING

All electrical wiring terminates in the control base wiring chamber. The base has standard 7/8" (22 mm) knockouts which accept common wiring hardware and conduit fittings. Before removing the knockouts, check the wiring diagram and select those sections of the chamber with common voltages. Do not allow the wiring to cross between sections, as the wires will interfere with safety dividers which should be installed at a later time.

Power must not be applied to any of the wires during the rough-in wiring stage.

- All wires are to be stripped to a length of 3/8" (9mm) to ensure proper connection to the control.
- Install the Outdoor Sensor 070 according to the instructions in the Data Brochure D 070, and run the wiring back to the control.
- If an Indoor Sensor 076 or 077 is used, install the indoor sensor(s) according to the instructions in the Data Brochure D 074, and run the wiring back to the control.
- If a Room Temperature Unit (RTU) 060 is used, install the RTU(s) according to the instructions in the Data Brochure D 060, and run the wiring back to the control. If a Room Temperature Unit (RTU) 062 or 063 is used, install the RTU(s) according to the instructions in the Data Brochure D 062, and run the wiring back to the control.
- If a Remote Display Module (RDM) 040 is used, install the module according to the instructions in the Data Brochure D 040, and run the wiring back to the control.
- If multiple zone controls are used, run two wires from one zone control to the next to create a chain.
- Run wiring from the system pump to the control.
- Run wires from each zone valve / pump to the control.
- Run wires from the 115 V (ac) power to the control. Use a clean power source with a 15 A circuit to ensure proper operation. The circuit breaker should be located near the control.
- Multi-strand 16 AWG wire is recommended for all 115 V (ac) wiring due to its superior flexibility and ease of installation into the terminals.

STEP FOUR — ELECTRICAL CONNECTIONS TO THE CONTROL

The installer should test to confirm that no voltage is present at any of the wires. Push the control into the base and slide it down until it snaps firmly into place.

⚠ **Powered Input Connections**

115 V (ac) Power

Connect the 115 V (ac) power supply to the *Power L* and *Power N* terminals (18 and 19). This connection provides power to the microprocessor and display of the control. As well, this connection provides power to the *Sys Pmp* terminal (17) from the *Power L* terminal (18).

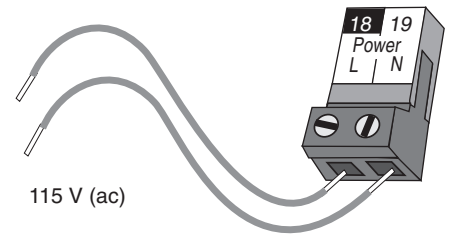

⚠ **Output Connections**

Cooling Contact

If a cooling system is used, connect the wires from the cooling unit to the *Cooling* terminals (15 and 16) on the control. The 369 closes a dry contact between these terminals when cooling is required.

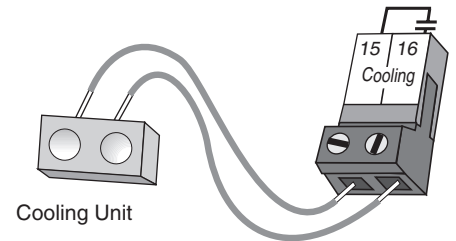

System Pump Contact (Sys Pmp)

The *Sys Pmp* output terminal (17) on the 369 is a powered output. When the relay in the 369 closes, 115 V (ac) is provided to the *Sys Pmp* terminal (17) from the *Power L* terminal (18). To operate the system pump, connect one side of the system pump circuit to the *Sys Pmp* terminal (17), and the second side of the pump circuit to the neutral (N) side of the 115 V (ac) power supply.

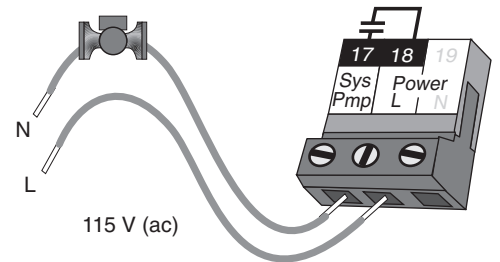

Zone Pumps and Zone Valves

Note: The zoning outputs are isolated terminals in the 369. There is no power available on these terminals from the control. Do not connect a zone pump and zone valve circuit to the same *Com* terminal.

If zone 1 is used, connect the zone pump or zone valve circuit to the *Com 1-2* and *Zn 1* (7 and 6) terminals on the control.

If zone 2 is used, connect the zone pump or zone valve circuit to the *Com 1-2* and *Zn 2* (7 and 8) terminals on the control.

If zone 3 is used, connect the zone pump or zone valve circuit to the *Com 3-4* and *Zn 3* (10 and 9) terminals on the control.

If zone 4 is used, connect the zone pump or zone valve circuit to the *Com 3-4* and *Zn 4* (10 and 11) terminals on the control.

If zone 5 is used, connect the zone pump or zone valve circuit to the *Com 5-6* and *Zn 5* (13 and 12) terminals on the control.

If zone 6 is used, connect the zone pump or zone valve circuit to the *Com 5-6* and *Zn 6* (13 and 14) terminals on the control.

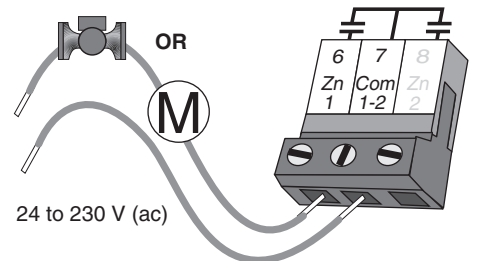

⚠ **Sensor and Unpowered Input Connections**

Do not apply power to these terminals as this will damage the control.

Outdoor Sensor

Connect the two wires from the Outdoor Sensor 070 to the *Com* and *Out* terminals (4 and 5). The outdoor sensor is used by the 369 to measure the outdoor air temperature.



Remote Display Module (RDM) 040 (Optional)

A Remote Display Module (RDM) 040 can be connected to the *tekmar Net™* (*tN1/2*) input. Connect the *Com* terminal from the RDM to the *Com* terminal (28) on the 369. Connect the *tN2* terminal from the RDM to the *tN1/2 5* terminal (29) on the 369. If an RDM is connected, the 369 is only capable of operating up to 5 zones.

Note: The wires from the RDM are polarity sensitive. The *tN2* device does not operate properly if the wires are reversed.

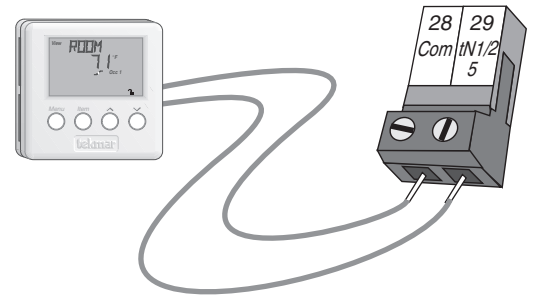

Zone Control Input and Output

Connect a wire between the *Com* (4) terminals on each 369. Connect the *Zo Out* terminal on the first 369 to the *Zo In* terminal on the second 369. With several zone controls, connect the *Zo Out* terminal on the second 369 to the *Zo In* terminal on the third 369 and continue this process for each additional 369. The *Zo Out* terminal on the last 369 in the chain can be connected to the *Zo In* terminal on a *tekmar House Control* or *10K* terminal on a *tekmar Reset Control*.

Note: The wires from the zone control are polarity sensitive. The system will not operate if the wires are reversed.

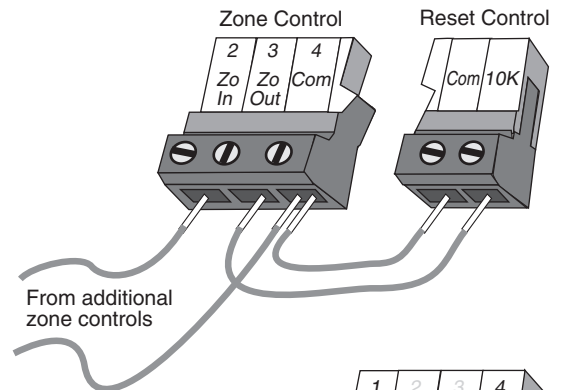

UnOccupied Switch

If an external timer or switch is used, connect the two wires from the external dry contact switch to the *Com* and *UnO Sw* (4 and 1) terminals. When these terminals short together, the control registers an Unoccupied signal.

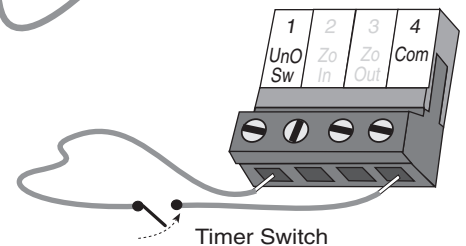

One Stage RTU and Indoor Sensor Connections.

RTUs and indoor sensors provide indoor temperature feedback to the control. An indoor sensor can only be used for the even numbered zones (i.e. zones 2, 4 and 6).

Note: The wires from the RTU are polarity sensitive. The RTU does not operate properly if the wires are reversed.

Zone 1 (*tN1 1*)

Connect the *Com* terminal from the RTU to the *Com* terminal (20) on the 369. Connect the *tN1* terminal from the RTU to the *tN1 1* terminal (21) on the 369.

Zone 2 (*tN1 2* or *Indr 2*)

Connect the *Com* terminal from the RTU to the *Com* terminal (20) on the 369. Connect the *tN1* terminal from the RTU to the *tN1 2* terminal (22) on the 369. If an indoor sensor is used, connect the two wires from the sensor to the *Com* and *Indr 2* terminals (20 and 23).

Note: If an RTU is connected to *tN1 2*, an indoor sensor can not be connected to *Indr 2*.

Zone 3 (*tN1 3*)

Connect the *Com* terminal from the RTU to the *Com* terminal (24) on the 369. Connect the *tN1* terminal from the RTU to the *tN1 3* terminal (25) on the 369.

Zone 4 (*tN1 4* or *Indr 4*)

Connect the *Com* terminal from the RTU to the *Com* terminal (24) on the 369. Connect the *tN1* terminal from the RTU to the *tN1 4* terminal (26) on the 369. If an indoor sensor is used, connect the two wires from the sensor to the *Com* and *Indr 4* terminals (24 and 27).

Note: If an RTU is connected to *tN1 4*, an indoor sensor can not be connected to *Indr 4*.

Zone 5 (*tN1/2 5*)

Connect the *Com* terminal from the RTU to the *Com* terminal (28) on the 369. Connect the *tN1* terminal from the RTU to the *tN1/2 5* terminal (29) on the 369.

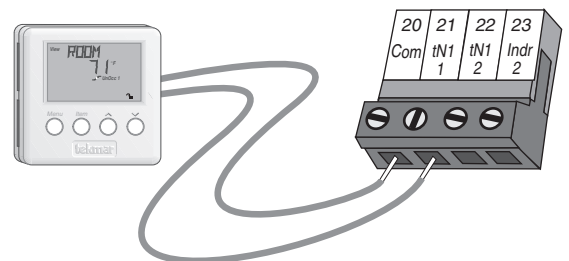

Zone 6 (*tN1 6* or *Indr 6*)

Connect the Com terminal from the RTU to the *Com* terminal (28) on the 369. Connect the *tN1* terminal from the RTU to the *tN1 6* terminal (30) on the 369. If an indoor sensor is used, connect the two wires from the sensor to the *Com* and *Indr 6* terminals (28 and 31).

Note: If an RTU is connected to *tN1 6*, an indoor sensor can not be connected to *Indr 6*.

Two Stage RTU and Indoor Sensor Connections.

RTUs and indoor sensors provide indoor temperature feedback to the control. An indoor sensor can only be used for the even numbered zones (i.e. zones 2, 4 and 6).

Note: The wires from the RTU are polarity sensitive. The RTU does not operate properly if the wires are reversed.

Zone 2 (*tN1 2* or *Indr 2*)

Connect the Com terminal from the RTU to the *Com* terminal (20) on the 369. Connect the *tN1* terminal from the RTU to the *tN1 2* terminal (22) on the 369. If an indoor sensor is used, connect the two wires from the sensor to the *Com* and *Indr 2* terminals (20 and 23).

Note: If an RTU is connected to *tN1 2*, an indoor sensor can not be connected to *Indr 2*.

Zone 4 (*tN1 4* or *Indr 4*)

Connect the Com terminal from the RTU to the *Com* terminal (24) on the 369. Connect the *tN1* terminal from the RTU to the *tN1 4* terminal (26) on the 369. If an indoor sensor is used, connect the two wires from the sensor to the *Com* and *Indr 4* terminals (24 and 27).

Note: If an RTU is connected to *tN1 4*, an indoor sensor can not be connected to *Indr 4*.

Zone 6 (*tN1 6* or *Indr 6*)

Connect the Com terminal from the RTU to the *Com* terminal (28) on the 369. Connect the *tN1* terminal from the RTU to the *tN1 6* terminal (30) on the 369. If an indoor sensor is used, connect the two wires from the sensor to the *Com* and *Indr 6* terminals (28 and 31).

Note: If an RTU is connected to *tN1 6*, an indoor sensor can not be connected to *Indr 6*.

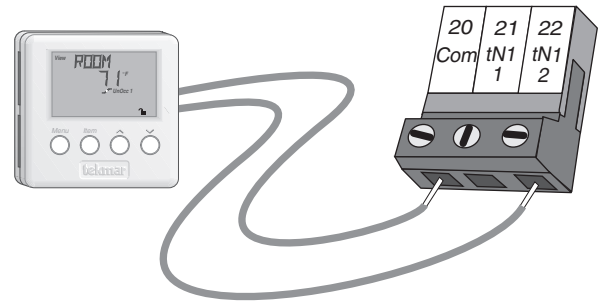

STEP FIVE — TESTING THE WIRING

Each terminal block **must be unplugged** from its header on the control before power is applied for testing. To remove a terminal block, pull it straight down from the control.

The following tests are to be performed using standard testing practices and procedures, and should only be carried out by properly trained and experienced persons.

A good quality electrical test meter, capable of reading from at least 0 - 300 V (ac) and at least 0 - 2,000,000 Ohms, is essential to properly test the wiring and sensors.

Test The Sensors

In order to test the sensors, the actual temperature at each sensor location must be measured. A good quality digital thermometer with a surface temperature probe is recommended for ease of use and accuracy. Where a digital thermometer is not available, a spare sensor can be placed alongside the one to be tested and the readings compared. Test the sensors according to the instructions in the Data Brochure D 070.

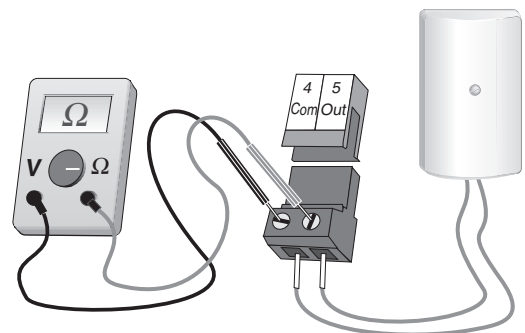

⚠ **Test The Power Supply**

Make sure exposed wires and bare terminals are not in contact with other wires or grounded surfaces. Turn on the power and measure the voltage between the *Power L* and *Power N* terminals (18 and 19) using an AC voltmeter. The reading should be between 103.5 and 126.5 V (ac).

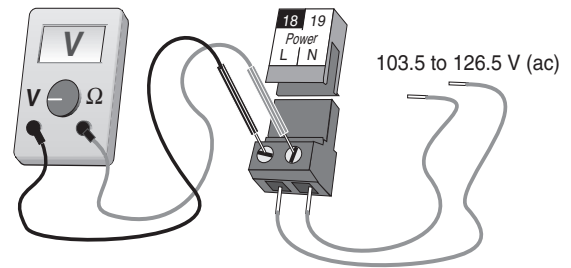

⚠ **Test The Outputs**

System Pump

If a system pump is connected to the *Sys Pmp* terminal (17), make sure power to the terminal block is off and install a jumper between the *Power L* and *Sys Pmp* terminals (18 and 17). When power is applied to the *Power L* and *Power N* terminals (18 and 19), the system pump should start. If the pump does not turn on, check the wiring between the terminal block and pump and refer to any installation or troubleshooting information supplied with the pump. If the pump operates properly, disconnect the power and remove the jumper.

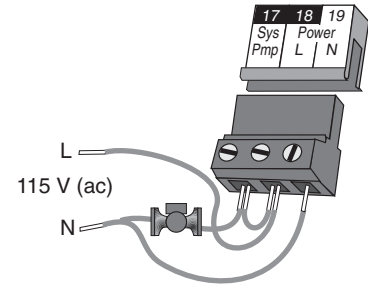

Cooling

If a cooling system is connected to the *Cooling* terminals (15 and 16), make sure power to the terminal block is off and install a jumper between the terminals. When the cooling circuit is powered up, the cooling unit should operate. If the cooling unit does not turn on, refer to any installation or troubleshooting information supplied with the cooling unit. If the cooling unit operates properly, disconnect the power and remove the jumper.

Zone Pump or Valve

If a zone pump or valve is connected to the *Com 1-2* and *Zn 1* terminals (7 and 6), make sure power to the pump or valve circuit is off and install a jumper between the *Com 1-2* and *Zn 1* terminals (7 and 6). When the zone circuit is powered up, the zone pump should turn on or the valve should open completely. If no response occurs, check the wiring between the terminal and the pump or valve and refer to any installation or troubleshooting information supplied with these devices.

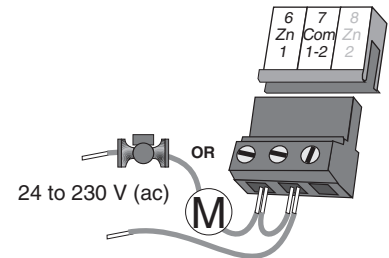

If a zone pump or valve is connected to the *Com 1-2* and *Zn 2* terminals (7 and 8), follow a similar procedure as described for the zone 1 relay.

If a zone pump or valve is connected to the *Com 3-4* and *Zn 3* terminals (10 and 9), follow a similar procedure as described for the zone 1 relay.

If a zone pump or valve is connected to the *Com 3-4* and *Zn 4* terminals (10 and 11), follow a similar procedure as described for the zone 1 relay.

If a zone pump or valve is connected to the *Com 5-6* and *Zn 5* terminals (13 and 12), follow a similar procedure as described for the zone 1 relay.

If a zone pump or valve is connected to the *Com 5-6* and *Zn 6* terminals (13 and 14), follow a similar procedure as described for the zone 1 relay.

⚠ **Connecting The Control**

Make sure all power to the devices and terminal blocks is off, and remove any remaining jumpers from the terminals.

Reconnect the terminal blocks to the control by carefully aligning them with their respective headers on the control, and then pushing the terminal blocks into the headers. The terminal blocks should snap firmly into place.

Install the supplied safety dividers between the unpowered sensor inputs and the powered 115 V (ac) or 24 V (ac) wiring chambers.

Apply power to the control. The operation of the control on power up is described in the *Sequence of Operation* section of this brochure.

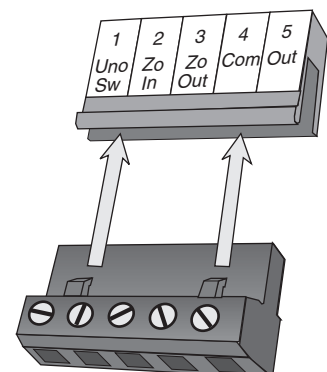

Cleaning

The control's exterior can be cleaned using a damp cloth. Moisten cloth with water and wring out prior to wiping control. Do not use solvents or cleaning solutions.

DIP Switch Settings

The DIP Switch settings on the control are very important and should be set to the appropriate settings prior to making any adjustments to the control through the user interface. The DIP switch settings change the items that are available to be viewed and/or adjusted in the user interface.

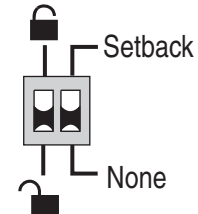

LOCK / UNLOCK

The *Lock / Unlock* DIP switch is used to lock and unlock the access level of the control and *tekmar Net™ tN1 / tN2* device(s). Once locked, access levels cannot be changed. To determine if the control is currently locked or unlocked, a small segment representing a padlock is viewed in the bottom right hand corner of the display. When the padlock is closed, the access level cannot be changed.

To change the access level, set the DIP switch to the unlocked or down position. The current access level of the control or *tekmar Net™ (tN1/2)* device is viewed in its Miscellaneous (Misc) menu. While viewing the access level, use the up and down keys to select between the Limited (LTD), User (USER), Installer (INST), or Advanced (ADV) access levels.

To lock the access level, select the appropriate access level in the Miscellaneous (Misc) menu and move the DIP switch from the *unlocked* position to the *locked* position. As long as the DIP switch is in the *locked* position, the access level of the control or *tekmar Net™ (tN1 / tN2)* device can no longer be viewed or adjusted in its Miscellaneous (Misc) menu.

SETBACK / NONE

The *Setback / None* DIP switch enables and disables the setback functions of the control. When the DIP switch is set to the *None* or down position, the control ignores any external setback signal, and its user interface does not display the *Unoccupied* adjustments.

When the DIP switch is set to the *Setback* position, the internal clock in the control is enabled. The control also responds to an external setback signal generated on the *UnO Sw* terminal.

Access Levels

The *tekmar Zone Control 369* comes with four Access Level settings. These Access Levels restrict the number of Menus, Items, and Adjustments that can be accessed by the user. The four access levels are Limited (LTD), User (USER), Installer (INST) and Advanced (ADV).

The access level of the control is found in the Miscellaneous (Misc) menu when the *Lock/Unlock* DIP switch is set to the *unlocked* position. In the Advanced access level, all of the control settings are available to the user. In the User access level, only a few of the menus and items are available. The Limited access level is the most restricted of them all. The control's factory setting is Installer (INST). This access level is sufficient for the normal set up of the control. Once the control is set up, the appropriate access level should be selected for the people that deal with the control on a regular basis.



369 View Menu (1 of 1)

Item Field	Access Level					Description	Range
	Section	LTD	USER	INST	ADV		
OUT DOOR	A1	●	●	●	●	Current outdoor air temperature as measured by the outdoor sensor. This is also the default display for the control.	---, -67 to 149°F (-55 to 65°C)
ROOM 1	A1	●	●	●	●	Current room air temperature of zone 1.	---, -58 to 167°F (-50 to 75°C)
ROOM 2	A1	●	●	●	●	Current room air temperature of zone 2.	---, -58 to 167°F (-50 to 75°C)
ROOM 3	A1	●	●	●	●	Current room air temperature of zone 3.	---, -58 to 167°F (-50 to 75°C)
ROOM 4	A1	●	●	●	●	Current room air temperature of zone 4.	---, -58 to 167°F (-50 to 75°C)
ROOM 5	A1	●	●	●	●	Current room air temperature of zone 5.	---, -58 to 167°F (-50 to 75°C)
ROOM 6	A1	●	●	●	●	Current room air temperature of zone 6.	---, -58 to 167°F (-50 to 75°C)
ZO IN	A1				●	This is the signal that is being received from a zone control.	OFF, 30 to 110°F (OFF, -1 to 43°C)
ZO OUT	A1				●	This is the signal that is being sent to a reset or additional zone control.	OFF, 30 to 110°F (OFF, -1 to 43°C)

369 Control Adjust Menu (1 of 2)

Item Field	Access Level					Description	Range	Actual Setting
	Section	LTD	USER	INST	ADV			
COOL MOD	B1			●	●	The operating mode for the <i>Cooling</i> relay. If COOL MOD = CTRL, a display RTU must be connected to tN 6	NONE, ENBL, CTRL Default = NONE	
MIN RUN	B1			●	●	The minimum run time for the <i>Cooling</i> relay. COOL MOD ≠ NONE	0:30 to 5:00 min Default = 2:00 min	
MIN OFF	B1			●	●	The minimum off time for the <i>Cooling</i> relay. COOL MOD ≠ NONE	0:30 to 10:00 min Default = 5:00 min	
COOL CYC	B3			●	●	The cycle length used for cooling operation. COOL MOD = CTRL	AUTO, 5:00 to 30:00 min Default = 15:00 min	

369 Control Adjust Menu (2 of 2)

Item Field	Access Level					Description	Range	Actual Setting
	Section	LTD	USER	INST	ADV			
INTRLOCK	B1		<input type="radio"/>	<input checked="" type="radio"/>		The time the heating zones assigned to the cooling group must be off before cooling operation is allowed. COOL MOD ≠ NONE	0:10 to 3:00 hr Default = 0:30 hr	
COOL OPT	B3			<input checked="" type="radio"/>		Enables or disables the Optimum Start feature for the cooling system. COOL MOD = CTRL	NONE, STRT Default = NONE	
THRM OPN	A1			<input checked="" type="radio"/>		The time required for a thermal zone valve to open. any ZNi OUTP = THRM (i = 1, . . . , 6)	0:30 to 4:00 min Default = 3:00 min	
THRM CLS	A1			<input checked="" type="radio"/>		The time required for a thermal zone valve to close. any ZNi OUTP = THRM (i = 1, . . . , 6)	0:10 to 2:00 min Default = 0:30 min	
PURGE	A1			<input checked="" type="radio"/>		The maximum length of time that a zone device and the system pump continues to operate after a heat demand is removed.	OFF, 0:10 to 4:00 min Default = 0:30 min	
HEAT CYC	A1			<input checked="" type="radio"/>		The cycle length used for heating operation.	5:00 to 30:00 min Default = 15:00 min	
EXERCISE	A1			<input checked="" type="radio"/>		The frequency with which the control exercises the pumps and valves that are operated by the control.	30 to 240 hr, OFF Default = 70 hr	

369 Zone Adjust Menu (1 of 2)

Note: The Zone Adjust menu is repeated for each zone that an RTU or indoor sensor is connected to. The Zone Adjust menu is indicated by *Adjust* in the left hand side of the display, and *Zone* followed by the zone number in the bottom of the display.

Item Field	Access Level					Description	Range	Actual Setting
	Section	LTD	USER	INST	ADV			
ZN 1 OUTP	A1		<input type="radio"/>	<input checked="" type="radio"/>		The type of zoning device that is to be used. (RTU or indoor sensor is present.)	PUMP, VLV, THRM Default = VLV	
STG NUM	A2 A3		<input type="radio"/>	<input checked="" type="radio"/>		Selects single stage or two stage operation. (RTU or indoor sensor is present in even zone, and RTU is not present in the preceding odd zone.)	ONE, TWO Default = ONE	
ZN 1 COOL	B1		<input type="radio"/>	<input checked="" type="radio"/>		Selects if this zone is part of the cooling group. (RTU or indoor sensor is present; Zone 1 to Zone 5.) COOL MOD ≠ NONE	NONE, CG Default = CG	
HT 1 SCHED	C		<input type="radio"/>	<input checked="" type="radio"/>		Selects if this zone is operated on the control schedule. (Non-display RTU or indoor sensor is present.) DIP switch = Setback	NONE, CTRL Default = NONE	

369 Zone Adjust Menu (2 of 2)

Item Field	Access Level					Description	Range	Actual Setting
	Section	LTD	USER	INST	ADV			
HEATING2 Occ	A1			●	●	Desired room air temperature during an occupied period. (Indoor sensor is present.)	35 to 100°F (2 to 38°C) Default = 70°F (21°C)	
HEATING1 UnOcc	C			●	●	Desired room air temperature during an unoccupied period. (Non-display RTU or indoor sensor is present.) DIP switch = Setback	35 to 100°F (2 to 38°C) Default = 65°F (18°C)	
HEAT OPT	C			●		Enables or disables the Optimum Start / Stop feature for this zone. (Non-display RTU or indoor sensor is present.) DIP switch = Setback	NONE, STRT, STOP, BOTH Default = BOTH	

369 Monitor Menu (1 of 2)

Note: To clear the recorded information in the specific item field, press and hold ▲ and ▼.

Item Field	Access Level					Description	Range
	LTD	USER	INST	ADV			
OUT HI	●	●	●	●		The highest recorded outdoor air temperature since this item was last cleared. This can be used to diagnose if the Outdoor Sensor 070 has been located correctly. If this reading is too high the 070 may be located in a location that receives direct sun light or is influenced by an exhaust vent.	-67 to 149°F (-55 to 65°C)
OUT LO	●	●	●	●		The lowest recorded outdoor air temperature since this item was last cleared. This can be used to diagnose if the Outdoor Sensor 070 has been located correctly. If this reading is too high there may not be adequate insulation behind the 070, or it may be too close to an exhaust vent.	-67 to 149°F (-55 to 65°C)
SYS PMP			●	●		The total number of system pump (<i>Sys Pmp</i>) running hours since this item was last cleared.	0 to 9999 hr
COOL			●	●		The total number of <i>Cooling</i> relay running hours since this item was last cleared.	0 to 9999 hr
ZONE 1			●	●		The total number of <i>Zn 1</i> relay running hours since this item was last cleared.	0 to 9999 hr
ZONE 2			●	●		The total number of <i>Zn 2</i> relay running hours since this item was last cleared.	0 to 9999 hr
ZONE 3			●	●		The total number of <i>Zn 3</i> relay running hours since this item was last cleared.	0 to 9999 hr
ZONE 4			●	●		The total number of <i>Zn 4</i> relay running hours since this item was last cleared.	0 to 9999 hr

369 Monitor Menu (2 of 2)

Note: To clear the recorded information in the specific item field, press and hold ▲ and ▼.

Item Field	Access Level				Description	Range
	LTD	USER	INST	ADV		
ZONE 5		●	●		The total number of Zn 5 relay running hours since this item was last cleared.	0 to 9999 hr
ZONE 6		●	●		The total number of Zn 6 relay running hours since this item was last cleared.	0 to 9999 hr
COP			●		The number of times that the microprocessor in the control has reset since this item was last cleared. The control will reset itself if it has experienced some form of interference that has disrupted its operation. This can be used to give an indication of the quality of the electrical environment that the control has been installed in.	0 - 255
NON-COP			●		The number of times that the control has been powered up since this item was last cleared. This number will increase if there is a lowering of the input voltage beyond the control's usable range. This item can also be used as an indication of the quality of the power source.	0 - 255

369 Time Menu (1 of 1)

Item Field	Section	Access Level				Description	Range
		LTD	USER	INST	ADV		
SATURDAY 12:00 AM	C	●	●	●	●	Displays current time of day and the day of week. DIP switch = Setback	
12:00	C		●	●	●	Real time clock minutes. DIP switch = Setback	:00 to :59 Default = :00
12:00 AM	C		●	●	●	Real time clock hours. DIP switch = Setback	12: AM to 11: PM or 00: to 23: Default = 12: AM
SATURDAY	C		●	●	●	Day of the week. DIP switch = Setback	SATURDAY, . . . , FRIDAY Default = SATURDAY
12/24 hr	C		●	●		Method of displaying time on the control's display. DIP switch = Setback	12 hr, 24 hr Default = 12 hr

Item Field	Access Level					Description	Range
	Section	LTD	USER	INST	ADY		
OVERRIDE	C	●	○	●		The type of setback override that is in effect for all schedules. DIP switch = Setback AWAY is available even if DIP switch ≠ Setback	NONE, TMPY Occ Ovr, PERM Occ Ovr, TMPY UnOcc Ovr, PERM UnOcc Ovr, AWAY Default = NONE
7DAY/24h	C	●	○	●		Selects the same schedule for each day of the week, or a separate schedule for each day of the week. DIP switch = Setback	7DAY24hr Default = 7DAY



If the 7DAY/24h item is set to 7DAY, the schedule listed below for SATURDAY is also available for SUNDAY, MONDAY, TUESDAY, WEDNESDAY, THURSDAY and FRIDAY.

SATURDAY Occ 1	C	●	○	●		Time when the first occupied period begins on Saturday. 7DAY/24h = 7DAY DIP switch = Setback	--:-- to 11:50 PM or --:-- to 23:50 Default = --:--
SATURDAY UnOcc 1	C	●	○	●		Time when the first unoccupied period begins on Saturday. 7DAY/24h = 7DAY DIP switch = Setback	--:-- to 11:50 PM or --:-- to 23:50 Default = --:--
SATURDAY Occ 2	C	●	○	●		Time when the second occupied period begins on Saturday. 7DAY/24h = 7DAY DIP switch = Setback	--:-- to 11:50 PM or --:-- to 23:50 Default = --:--
SATURDAY UnOcc 2	C	●	○	●		Time when the second unoccupied period begins on Saturday. 7DAY/24h = 7DAY DIP switch = Setback	--:-- to 11:50 PM or --:-- to 23:50 Default = --:--
ALL DAYS Occ 1	C	●	○	●		Time when the first occupied period begins every day. 7DAY/24h = 24hr DIP switch = Setback	--:-- to 11:50 PM or --:-- to 23:50 Default = --:--
ALL DAYS UnOcc 1	C	●	○	●		Time when the first unoccupied period begins every day. 7DAY/24h = 24hr DIP switch = Setback	--:-- to 11:50 PM or --:-- to 23:50 Default = --:--
ALL DAYS Occ 2	C	●	○	●		Time when the second occupied period begins every day. 7DAY/24h = 24hr DIP switch = Setback	--:-- to 11:50 PM or --:-- to 23:50 Default = --:--
ALL DAYS UnOcc 2	C	●	○	●		Time when the second unoccupied period begins every day. 7DAY/24h = 24hr DIP switch = Setback	--:-- to 11:50 PM or --:-- to 23:50 Default = --:--

During a schedule, the two occupied and two unoccupied events follow a sequence. The schedule must be set properly in order for the events to occur as desired.

Each event must be set to occur after the previous event in the following order:

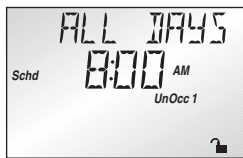
Example:

<p>Occ 1 →</p>  <p>From 6:00 am to 8:00 am is the first occupied event.</p>	<p>UnOcc 1 →</p>  <p>From 8:00 am to 5:00 pm is the first unoccupied event.</p>	<p>Occ 2 →</p>  <p>From 5:00 pm to 10:00 pm is the second occupied event.</p>	<p>UnOcc 2 →</p>  <p>From 10:00 pm to 6:00 pm is the second unoccupied event.</p>
--	--	---	--

Note: To skip an event during a schedule, select the "Null" event. Use the arrow keys to select the "Time" between 11:50 PM and 12:00 AM. "--:--" is displayed indicating that the event will not occur during the schedule.

369 Misc (Miscellaneous) Menu (1 of 1)

Item Field	Access Level				Description	Range
	LTD	USER	INST	ADV		
UNITS	●	●	●	●	The units of measure that all of the temperatures are to be displayed.	°F, °C Default = °F
BACKLITE	●	●	●	●	The operating mode for the back lighting on the LCD as well as the time of keypad inactivity until the control automatically returns to the default display. BACKLITE = OFF (returns after 10 seconds) BACKLITE = 30 sec (returns after 30 seconds) BACKLITE = ON (returns after 90 seconds)	OFF, 30 sec, ON Default = ON
ACCESS	●	●	●	●	The access level that is to be used by the control. DIP switch = Unlock	ADV, INST, USER, LTD Default = INST

Room Temperature Units (RTUs) 062 and 063



A display RTU may be connected to the Zone Control 369 in order to provide the control with indoor temperature feedback for the heating system (Refer to Essay E 002). When using display RTUs, several items related to the system are no longer available in the control's User Interface. These items are available only in the RTU's User Interface. Also, the number of items that are available on the RTU depends on the type of RTU that is connected to the control.

369 RTU View Menu (1 of 1)

Item Field	Section	Access Level				RTU 062	RTU 063	Description	Range
		LTD	USER	INST	ADV				
COOL AVG	D	●	●	●	●	●	●	Average temperature of all the zones assigned to the cooling group. COOL MODE = CTRL and RTU 6	---, 20 to 120°F (7 to 49°C)
ROOM	D	●	●	●	●	●	●	Current room air temperature.	---, 20 to 120°F (7 to 49°C)
ROOM TRG	D	●	●	●	●	●	●	Target room air temperature.	---, 35 to 100°F (2 to 38°C)
OUTDOOR	D	●	●	●	●	●	●	Current outdoor air temperature.	-67 to 140°F (-55 to 60°C)
SLAB	D	●	●	●	●	●	●	Current slab (floor) sensor temperature. REMOTE 3 = SLAB	-40 to 158°F (-40 to 70°C)

Item Field	Section	Access Level						Description	Range
		LTD	USER	INST	ADV	RTU 062	RTU 063		
MODE	B	●	●	●	●	●	●	The operating mode for this zone. RTU 1 to RTU 5 or RTU 6 if COOL MOD = NONE	OFF, HEAT Default = HEAT
MODE	B	●	●	●	●	●	●	The operating mode for this zone. RTU 6 only and COOL MOD ≠ NONE	OFF, HEAT, AUTO, COOL Default = AUTO
HEATING Occ	A	●	●	●	●	●	●	The desired heated room air temperature during an occupied period for this zone. Note: There is only a ±3°F (±1°C) adjustment in the LTD access level. MODE ≠ OFF	35 to 100°F (2 to 38°C) Default = 70°F (21°C)
HEATING UnOcc	C	●	●	●	●	●	●	The desired heated room air temperature during an unoccupied period for this zone. Note: There is only a ±3°F (±1°C) adjustment in the LTD access level. MODE ≠ OFF and DIP switch = Setback	35 to 100°F (2 to 38°C) Default = 65°F (18°C)
COOLING Occ	B3	●	●	●	●	●	●	The desired cooled room air temperature during an occupied period. Note: There is only a ±3°F (±1°C) adjustment in the LTD access level. RTU 6 and COOL MOD = CTRL	35 to 100°F (2 to 38°C) Default = 75°F (24°C)
COOLING UnOcc	C	●	●	●	●	●	●	The desired cooled room air temperature during an unoccupied period. Note: There is only a ±3°F (±1°C) adjustment in the LTD access level. COOL MOD = CTRL, RTU 6 and DIP switch = Setback	35 to 100°F (2 to 38°C) Default = 78°F (26°C)
RTU SENS	D			●	●	●	●	Selects whether the RTU is to use its internal air sensor.	OFF, AIR Default = AIR
REMOTE 1	D			●	●		●	This item allows for remotely adding a 10K sensor to the RTU. Applications are for temperature averaging.	NONE, AIR Default = NONE
REMOTE 2	D			●	●		●	This item allows for remotely adding a second 10K sensor to the RTU. Applications are for temperature averaging.	NONE, AIR Default = NONE
REMOTE 3	D			●	●		●	This item allows for remotely adding a third 10K sensor to the RTU, or a 10K slab sensor to measure slab temperature.	NONE, AIR, SLAB Default = NONE
SLAB MIN	D	●	●	●	●		●	The minimum target temperature at the slab sensor. REMOTE 3 = SLAB	OFF, 35 to 120°F (OFF, 2 to 49°C) Default = 70°F (21°C)
SLAB MAX	D		●	●	●		●	The maximum target temperature at the slab sensor. REMOTE 3 = SLAB	40 to 150°F (4 to 66°C) Default = 90°F (32°C)

369 RTU Monitor Menu (1 of 1)

Note: To clear the recorded information in the specific item field, press and hold ▲ and ▼.

Item Field	Access Level						Description	Range
	LTD	USER	INST	ADV	RTU 062	RTU 063		
OUT HI	●	●	●	●	●	●	The highest outdoor air temperature recorded since this item was last cleared.	-67 to 140°F (-55 to 60°C)
OUT LO	●	●	●	●	●	●	The lowest outdoor air temperature recorded since this item was last cleared.	-67 to 140°F (-55 to 60°C)
ROOM HI		●	●	●	●	●	The highest room air temperature recorded since this item was last cleared.	20 to 120°F (-7 to 49°C)
ROOM LO		●	●	●	●	●	The lowest room air temperature recorded since this item was last cleared.	20 to 120°F (-7 to 49°C)
ROOM HOT				●	●	●	This is an adjustable item. If the air temperature measured by the RTU exceeds this setting, the control will display a warning message.	50 to 120°F, OFF (10 to 49°C, OFF) Default = OFF
ROOM CLI				●	●	●	This is an adjustable item. If the air temperature measured by the RTU drops below this setting, the control will display a warning message.	OFF, 20 to 80°F (OFF, -7 to 27°C) Default = OFF

369 RTU Time Menu (1 of 1)

Item Field	Access Level						Description	Range
	LTD	USER	INST	ADV	RTU 062	RTU 063		
SATURDAY 12:00 AM	●	●	●	●	●	●	Display time of day and the day of the week. DIP switch = Setback	
12:00		●	●	●	●	●	Real time clock minutes. DIP switch = Setback	:00 to :59 Default = :00
12:00 AM		●	●	●	●	●	Real time clock hours. DIP switch = Setback	12: AM to 11: PM or 00: to 23: Default = 12: AM
SATURDAY		●	●	●	●	●	Day of the week. DIP switch = Setback	SATURDAY, . . . , FRIDAY Default = SATURDAY
12/24 hr			●	●	●	●	Method of displaying time in the display. DIP switch = Setback	12 hr, 24 hr Default = 12 hr

Item Field	Section	Access Level						Description	Range
		LTD	USER	INST	ADV	RTU 062	RTU 063		
OVERRIDE	C			●	●	●	●	The type of setback override that is in effect for all schedules. DIP switch = Setback AWAY is available even if DIP switch ≠ Setback	NONE, TMPY Occ Ovr, PERM Occ Ovr, TMPY UnOcc Ovr, PERM UnOcc Ovr, AWAY Ovr Default = NONE
ZONE OVR	C	●	●	●	●	●	●	The type of setback override that is in effect for this zone's schedule. Note: NONE, TMPY Occ Ovr and PERM UnOcc Ovr is available in the LTD access level. DIP switch = Setback	NONE, TMPY Occ Ovr, PERM Occ Ovr, TMPY UnOcc Ovr, PERM UnOcc Ovr, AWAY Ovr Default = NONE
HEAT SCH	C	●	●	●	●	●	●	The schedule this zone uses for heating. DIP switch = Setback	NONE, ZONE, CTRL Default = NONE
COOL SCH	C	●	●	●	●	●	●	The schedule that is to be used for the cooling system. COOL MOD ≠ NONE, RTU 6 and DIP switch = Setback	NONE, ZONE, CTRL Default = NONE
OPT STRT	C			●	●	●	●	Enables or disables the Optimum Start / Stop feature for this zone. DIP switch = Setback (Any air sensor on)	NONE, STRT, STOP, BOTH Default = BOTH
7DAY/24h	C	●	●	●	●	●	●	Selects the same schedule for each day of the week, or a separate schedule for each day of the week. DIP switch = Setback	7DAY24hr Default = 7DAY

If the 7DAY/24h adjustment is set to 7DAY, the schedule listed below for SATURDAY is also available for SUNDAY, MONDAY, TUESDAY, WEDNESDAY, THURSDAY and FRIDAY.

SATURDAY Occ 1	C	●	●	●	●	●	●	Time when the first occupied period begins on Saturday. 7DAY/24h = 7DAY DIP switch = Setback	--:-- to 11:50 PM or --:-- to 23:50 Default = --:--
SATURDAY UnOcc 1	C	●	●	●	●	●	●	Time when the first unoccupied period begins on Saturday. 7DAY/24h = 7DAY DIP switch = Setback	--:-- to 11:50 PM or --:-- to 23:50 Default = --:--
SATURDAY Occ 2	C	●	●	●	●	●	●	Time when the second occupied period begins on Saturday. 7DAY/24h = 7DAY DIP switch = Setback	--:-- to 11:50 PM or --:-- to 23:50 Default = --:--
SATURDAY UnOcc 2	C	●	●	●	●	●	●	Time when the second unoccupied period begins on Saturday. 7DAY/24h = 7DAY DIP switch = Setback	--:-- to 11:50 PM or --:-- to 23:50 Default = --:--
ALL DAYS Occ 1	C	●	●	●	●	●	●	Time when the first occupied period begins every day. 7DAY/24h = 24hr DIP switch = Setback	--:-- to 11:50 PM or --:-- to 23:50 Default = --:--
ALL DAYS UnOcc 1	C	●	●	●	●	●	●	Time when the first unoccupied period begins every day. 7DAY/24h = 24hr DIP switch = Setback	--:-- to 11:50 PM or --:-- to 23:50 Default = --:--
ALL DAYS Occ 2	C	●	●	●	●	●	●	Time when the second occupied period begins every day. 7DAY/24h = 24hr DIP switch = Setback	--:-- to 11:50 PM or --:-- to 23:50 Default = --:--
ALL DAYS UnOcc 2	C	●	●	●	●	●	●	Time when the second unoccupied period begins every day. 7DAY/24h = 24hr DIP switch = Setback	--:-- to 11:50 PM or --:-- to 23:50 Default = --:--

For an example on how to set a schedule, refer to the Example given in the Schedule menu of the 369.
Note: To skip an event during a schedule, select the "Null" event. Use the arrow keys to select the "Time" between 11:50 PM and 12:00 AM. "--:--" is displayed indicating that the event will not occur during the schedule.

Item Field	Access Level						Description	Range
	LTD	USER	INST	ADV	RTU 062	RTU 063		
LIN ITS	●	○	●	○	●	○	The units of measure that all of the temperatures are to be displayed.	°F, °C Default = °F
BACKLITE	●	○	●	○	●	○	The operating mode for the back lighting on the LCD as well as the time of keypad inactivity until the control automatically returns to the default display. BACKLITE = OFF (returns after 10 seconds) BACKLITE = 30 s (returns after 30 seconds) BACKLITE = ON (returns after 90 seconds)	OFF, 30 sec, ON Default = ON
ACCESS	○	●	○	●	○	●	The access level that is to be used by the RTU. DIP switch = Unlock	ADV, INST, USER, LTD Default = INST
WIRING	○	○	○	○	○	○	Displays which <i>tn1</i> terminal on the 369 this RTU is connected to.	RTU1. . . RTU6

Testing the Control

The Zone Control 369 has a built in test routine which is used to test the main control functions. The 369 continually monitors the sensors and displays an error message whenever a fault is found. See the following pages for a list of the 369's error messages and possible causes. When the **Test** button is pressed, the test light is turned on. The individual outputs and relays are tested in the following sequence.

off not testing
 → red ← testing
 red testing paused



TEST SEQUENCE

Each step in the test sequence lasts 10 seconds.

During the test routine, the test sequence is paused by pressing the **Test** button. While paused, the control displays the testing step as well as the word PAUS. If the **Test** button is not pressed again for 5 minutes while the test sequence is paused, the control exits the entire test routine. If the test sequence is paused, the **Test** button can be pressed again to advance to the next step. This can also be used to rapidly advance through the test sequence. To reach the desired step, repeatedly press and release the **Test** button until the appropriate device and segment in the display turn on.

- Step 1** - The system pump (*Sys Pmp*) relay is turned on for 10 seconds. After 10 seconds, the *Sys Pmp* relay is shut off.
- Step 2** - If COOL MOD is set to ENBL or CTRL, the control turns on the *Cooling* relay for 10 seconds. After 10 seconds, the *Cooling* relay is shut off.
- Step 3** - If zone 1 (*tn1 1*) is used for a one stage heating zone, the control turns on relay *Zn 1* for 10 seconds. After 10 seconds, the *Zn 1* relay is shut off. If an RTU is not connected to *tn1 1*, the control skips this step.
- Step 4** - If zone 2 (*tn1 2* or *Indr 2*) is used for a one stage heating zone, the control turns on relay *Zn 2* for 10 seconds. After 10 seconds, the *Zn 2* relay is shut off.
- If zone 2 (*tn1 2* or *Indr 2*) is used for a two stage heating zone, the control turns on relay *Zn 1* for 10 seconds. After 10 seconds, the *Zn 1* relay is shut off. The *Zn 2* relay is then turned on for 10 seconds. After 10 seconds, the *Zn 2* relay is shut off.
- If an RTU or indoor sensor is not connected to *tn1 2* or *Indr 2*, the control skips this step.
- Step 5** - The control tests relay *Zn 3* using the procedure described in Step 3.
- Step 6** - The control tests relay *Zn 4* using the procedure described in Step 4.
- Step 7** - The control tests relay *Zn 5* using the procedure described in Step 3.
- Step 8** - The control tests relay *Zn 6* using the procedure described in Step 4.

MAX HEAT (MAX HEAT)

The Zone Control 369 has a function called Max Heat. In this mode, the 369 sets all RTU room temperature settings to 75°F (24°C) and turns on the required contacts. The RTU room setting may be adjusted to turn on or off the required zone without delay. The control continues to operate in this mode for up to 24 hours or until either the **Item**, **Menu** or **Test** button is pressed. To enable the Max Heat feature, use the following procedure.

- 1) Press and hold the **Test** button for more than 3 seconds. At this point, the control displays the words MAX HEAT and the word NO.
- 2) Using the Up or Down buttons, select the word YES. After 3 seconds, the control flashes the word MAX HEAT TEST.
- 3) To cancel the Max Heat mode, press either the **Item**, **Menu**, or **Test** button.
- 4) Once the Max Heat mode has either ended or is cancelled, the control resumes normal operation.

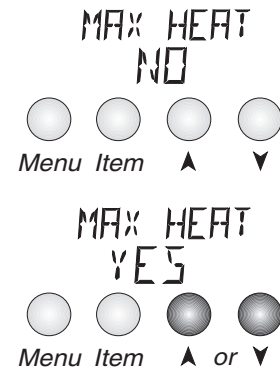

Troubleshooting

When troubleshooting any heating system, it is always a good idea to establish a set routine to follow. By following a consistent routine, many hours of potential headaches can be avoided. Below is an example of a sequence that can be used when diagnosing or troubleshooting problems in a hydronic heating system.

Establish the Problem

Establish the problem. Get as much information from the customer as possible about the problem. Is there too much heat, not enough heat, or no heat? Is the problem only in one particular zone or area of the building or does the problem affect the entire system? Is this a consistent problem or only intermittent? How long has the problem existed for? This information is critical in correctly diagnosing the problem.

Understand the Sequence of Operation

Understand the sequence of operation of the system. If a particular zone is not receiving enough heat, which pumps or valves in the system must operate in order to deliver heat to the affected zone? If the zone is receiving too much heat, which pumps, valves or check valves must operate in order to stop the delivery of heat?

Use the Test Routine

Press the **Test** button on the control and follow the control through the test sequence as described in the Testing section. Pause the control as necessary to ensure that the correct device is operating as it should.

Sketch the Piping in the System

Sketch the piping of the system. This is a relatively simple step that tends to be overlooked, however it can often save hours of time troubleshooting a system. Note flow directions in the system paying close attention to the location of pumps, check valves, pressure bypass valves and mixing valves. Ensure correct flow direction on all pumps. This is also a very useful step if additional assistance is required.

Document the Control

Document the control for future reference. Before making any adjustments to the control, note down all of the items that the control is currently displaying. This includes items such as error messages, current temperatures and settings, and which devices should be operating as indicated by the LCD. This information is an essential step if additional assistance is required to diagnose the problem.

Isolate the Problem

Isolate the problem between the control and the system. Now that the sequence of operation is known and the system is sketched, is the control operating the proper pumps and valves at the correct times? Is the control receiving the correct signals from the system as to when it should be operating? Are the proper items selected in the menus of the control for the device that is to be operated?

Test the Contacts Voltages & Sensors

Test the contacts, voltages and sensors. Using a multimeter, ensure that the control is receiving adequate voltage to the power terminals as noted in the technical data. Use the multimeter to determine if the internal contacts on the control are opening and closing correctly. Follow the instructions in the Testing the Wiring section to simulate closed contacts on the terminal blocks as required. Test the sensors and their wiring as described in the sensor Data Brochures.

Monitor the System

Monitor the system over a period of time. Select the applicable items in the Monitor menu of the control and reset them to zero. Allow the system and the control to operate over a known period of time and then record the Monitor items. Use this information to help diagnose any remaining problems.

369 Error Messages (1 of 3)

Error Displayed	Description of Error
CTRL ERR EE W	The control was unable to store a piece of information into its EEPROM. This error can be caused by a noisy power source. The control will display the error message and will continue to operate as normal. Pressing either the Menu or item button will clear this error.
CTRL ERR ADJLS	The control was unable to read a piece of information stored in the Adjust Menu. Because of this, the control was required to load the factory settings into all of the items in the Adjust menu. The control will stop operation until all of the items available in the Adjust menu of the control have been checked by the user or installer. Note: Access level must be ADV in order to clear the error.
CTRL ERR MNTR	The control was unable to read a piece of information stored in the Monitor Menu. Because of this, the control was required to load the factory settings into all of the items in the Monitor menu. The control will continue to display the error message until all of the items available in the Monitor menu of the control have been checked by the user or installer. Note: Access level must be ADV in order to clear the error.
CTRL ERR SCHD	The control was unable to read a piece of information stored in the Schedule Menu. Because of this, the control was required to load the factory settings into all of the items in the Schedule menu. The control will continue to display the error message until all of the items available in the Schedule menu of the control have been checked by the user or installer. Note: Access level must be ADV in order to clear the error.
CTRL ERR MISC	The control was unable to read a piece of information stored in the Miscellaneous Menu. Because of this, the control was required to load the factory settings into all of the items in the Miscellaneous menu. The control will continue to display the error message until all of the items available in the Miscellaneous menu of the control have been checked by the user or installer. Note: Access level must be ADV in order to clear the error.

369 Error Messages (2 of 3)

The error messages listed below for RTU 1 will be the same for RTU 2, RTU 3, RTU 4, RTU 5 and RTU 6.

<p>RTU1 ERR EE W</p>	<p>RTU 1 was unable to store a piece of information into its EEPROM. This error can be caused by a noisy power source. The control will display the error message and will continue to operate as normal. Pressing either the Menu or Item button will clear this error.</p>
<p>RTU1 ERR ADJ5</p>	<p>RTU 1 was unable to read a piece of information stored in the Adjust Menu. Because of this, the control was required to load the factory settings into all of the items in the Adjust menu. The control will stop operation until all of the items available in the Adjust menu of the control have been checked by the user or installer. Note: Access level must be ADV in order to clear the error.</p>
<p>RTU1 ERR MNTR</p>	<p>RTU 1 was unable to read a piece of information stored in the Monitor Menu. Because of this, the control was required to load the factory settings into all of the items in the Monitor menu. The control will continue to display the error message until all of the items available in the Monitor menu of the control have been checked by the user or installer. Note: Access level must be ADV in order to clear the error.</p>
<p>RTU1 ERR SCHD</p>	<p>RTU 1 was unable to read a piece of information stored in the Schedule Menu. Because of this, the control was required to load the factory settings into all of the items in the Schedule menu. The control will continue to display the error message until all of the items available in the Schedule menu of the control have been checked by the user or installer. Note: Access level must be ADV in order to clear the error.</p>
<p>RTU1 ERR MISC</p>	<p>RTU 1 was unable to read a piece of information stored in the Miscellaneous Menu. Because of this, the control was required to load the factory settings into all of the items in the Miscellaneous menu. The control will continue to display the error message until all of the items available in the Miscellaneous menu of the control have been checked by the user or installer. Note: Access level must be ADV in order to clear the error.</p>

The error messages listed below for 1 tN1 will be the same for 2 tN1, 3 tN1, 4 tN1, 5 tN1 and 6 tN1.

<p>tN1 TYPE</p>	<p>An incorrect device has been connected to the <i>tekmar Net™ tN1 1</i> input terminal. Once the problem has been corrected, press either the Menu or Item button to clear the error message from the control.</p>
<p>tN1 SHRT</p>	<p>A short circuit has been read between the <i>tN1 1</i> terminal and a <i>Com</i> terminal on the control. Either the wires leading to the RTU device are shorted or the polarity of the wires are reversed. Determine the cause and remove the short. To clear this error, press either the Menu or Item button.</p>
<p>tN1 OPEN</p>	<p>The control is no longer able to read the information that is coming from RTU 1. Reconnect the RTU and press either the Menu or Item button to clear the error. If the RTU has been deliberately disconnected from the control, remove power from the control for 10 seconds and then repower the control in order to clear the error message.</p>
<p>OUT DOOR SHRT</p>	<p>The control is no longer able to read the outdoor sensor due to a short circuit. In this case the control assumes an outdoor temperature of 32°F (0°C) and continues operation. Locate and repair the problem as described in the Data Brochure D070. To clear the error message from the control after the sensor has been repaired, press either the Menu or Item button.</p>
<p>OUT DOOR OPEN</p>	<p>The control is no longer able to read the outdoor sensor due to an open circuit. In this case the control assumes an outdoor temperature of 32°F (0°C) and continues operation. Locate and repair the problem as described in the Data Brochure D070. To clear the error message from the control after the sensor has been repaired, press either the Menu or Item button.</p>
<p>RTU1 SEN SHRT</p>	<p>A short circuit has been read between the <i>tN1 1</i> terminal and a <i>Com</i> terminal on the control. Either the wires leading to the RTU device are shorted or the polarity of the wires are reversed. Determine the cause and remove the short. To clear this error, press either the Menu or Item button.</p>

369 Error Messages (3 of 3)

The error messages listed below for RTU 1 will be the same for RTU 2, RTU 3, RTU 4, RTU 5 and RTU 6.

Error Displayed	Description of Error
RTU1 SEN OPEN	The control is no longer able to read the information that is coming from RTU 1. Reconnect RTU 1 and press either the Menu or Item button to clear the error. If the RTU has been deliberately disconnected from the control, remove power from the control for 10 seconds and the repower the control in order to clear the error message.
RTU1 RM1 SHRT	The Remote 1 Sensor attached to RTU 1 is being read as a short circuit. RTU 1 will continue operation using all remaining sensors. If all of the sensors are unavailable, the control will continue to operate as if RTU 1 was not connected to the control. This error message can be cleared once the sensor has been repaired. Locate and repair the problem as described in the Data Brochure D 070. To clear the error message from the control, press either the Menu or Item button. REMOTE 1 ≠ NONE.
RTU1 RM1 OPEN	The Remote 1 Sensor attached to RTU 1 is being read as an open circuit. RTU 1 will continue operation using all remaining sensors. If all of the sensors are unavailable, the control will continue to operate as if RTU 1 was not connected to the control. This error message can be cleared once the sensor has been repaired. Locate and repair the problem as described in the Data Brochure D 070. To clear the error message from the control, press either the Menu or Item button. REMOTE 1 ≠ NONE
RTU1 RM2 SHRT	The Remote 2 Sensor attached to RTU 1 is being read as a short circuit. RTU 1 will continue operation using all remaining sensors. If all of the sensors are unavailable, the control will continue to operate as if RTU 1 was not connected to the control. This error message can be cleared once the sensor has been repaired. Locate and repair the problem as described in the Data Brochure D 070. To clear the error message from the control, press either the Menu or Item button. REMOTE 2 ≠ NONE
RTU1 RM2 OPEN	The Remote 2 Sensor attached to RTU 1 is being read as an open circuit. RTU 1 will continue operation using all remaining sensors. If all of the sensors are unavailable, the control will continue to operate as if RTU 1 was not connected to the control. This error message can be cleared once the sensor has been repaired. Locate and repair the problem as described in the Data Brochure D 070. To clear the error message from the control, press either the Menu or Item button. REMOTE 2 ≠ NONE
RTU1 RM3 SHRT	The Remote 3 Sensor attached to RTU 1 is being read as a short circuit. RTU 1 will continue operation using all remaining sensors. If all of the sensors are unavailable, the control will continue to operate as if RTU 1 was not connected to the control. This error message can be cleared once the sensor has been repaired. Locate and repair the problem as described in the Data Brochure D 070. To clear the error message from the control, press either the Menu or Item button. REMOTE 3 ≠ NONE
RTU1 RM3 OPEN	The Remote 3 Sensor attached to RTU 1 is being read as an open circuit. RTU 1 will continue operation using all remaining sensors. If all of the sensors are unavailable, the control will continue to operate as if RTU 1 was not connected to the control. This error message can be cleared once the sensor has been repaired. Locate and repair the problem as described in the Data Brochure D 070. To clear the error message from the control, press either the Menu or Item button. REMOTE 3 ≠ NONE
RTU6 ERR COOL	Cooling control is selected but there is no display RTU connected to the tN1 6 terminal. The control will continue to operate as if COOL MOD was set to NONE. To clear the error message from the control, press either the Menu or Item button.

The warning message listed below for ROOM 1 will be the same for ROOM 2, ROOM 3, ROOM 4, ROOM 5 and ROOM 6.

ROOM 1 HOT	This warning message will be displayed if the air temperature sensed by RTU 1 exceeds the setting of the ROOM HOT item in the Monitor menu of RTU 1. The control will continue to operate as normal with this warning. To clear the warning press either the Menu or Item button.
ROOM 1 COLD	This warning message will be displayed if the air temperature sensed by RTU 1 is below the setting of the ROOM HOT item in the Monitor menu of RTU 1. The control will continue to operate as normal with this warning. To clear the warning press either the Menu or Item button.

Technical Data

Zone Control 369 Six Zones

Literature	— D 369, U 369, A 369's, D 001, D 070.
Control	— Microprocessor PID control; This is not a safety (limit) control .
Packaged weight	— 3.5 lb. (1610 g)
Enclosure	— Blue PVC plastic
Dimensions	— 6-5/8" H x 7-9/16" W x 2-13/16" D (170 x 193 x 72 mm)
Approvals	— CSA C US, CSA/UL 1010-1, meets Class B: ICES & FCC Part 15
Ambient conditions	— Indoor use only, 32 to 122°F (0 to 50°C), < 90% RH non-condensing. Altitude <2000 m, Installation Category II, Pollution Degree 2
Power supply	— 115 V (ac) ±10%, 50/60 Hz, 600 VA
Relays	— 230 V (ac) 5 A
Sensors included	— NTC thermistor, 10 kΩ @ 77°F (25°C ±0.2°C) β=3892 Outdoor Sensor 070
Optional devices	— tekmar type #: 032, 040, 060, 062, 063, 076, 077, 367, 368, 369.

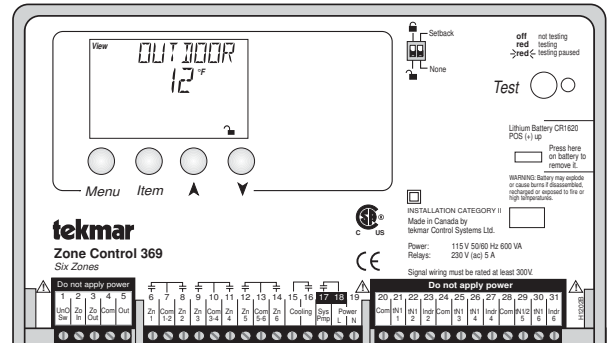

The installer must ensure that this control and its wiring are isolated and/or shielded from strong sources of electromagnetic noise. Conversely, this Class B digital apparatus complies with Part 15 of the FCC Rules and meets all requirements of the Canadian Interference-Causing Equipment Regulations. However, if this control does cause harmful interference to radio or television reception, which is determined by turning the control off and on, the user is encouraged to try to correct the interference by re-orientating or relocating the receiving antenna, relocating the receiver with respect to this control, and/or connecting the control to a different circuit from that to which the receiver is connected.

Cet appareil numérique de la classe B respecte toutes les exigences du Règlement sur le matériel brouilleur du Canada.

Caution The nonmetallic enclosure does not provide grounding between conduit connections. Use grounding type bushings and jumper wires.

Attention Un boîtier nonmétallique n'assure pas la continuité électrique des conduits. Utiliser des manchons ou des fils de accord spécialement conçus pour la mise à la terre.

Limited Warranty and Product Return Procedure

Limited Warranty The liability of tekmar Control Systems Ltd. and tekmar Control Systems, Inc. ("tekmar") under this warranty is limited. The purchaser, by taking receipt of the tekmar product ("product"), acknowledges receipt of the terms of the warranty and acknowledges that it has read and understands same.

tekmar warrants each tekmar product against defects in workmanship and materials, if the product is installed and used in compliance with tekmar's instructions. The warranty period is for a period of twenty-four (24) months from the production date if the product is not installed during that period, or twelve (12) months from the documented date of installation if installed within twenty-four (24) months from the production date.

The liability of tekmar under this warranty shall be limited to, at tekmar's sole discretion: the cost of parts and labor provided by tekmar to repair defects in materials and/or workmanship of the defective product; or to the exchange of the defective product for a replacement product; or to the granting of credit limited to the original cost of the defective product, and such repair, exchange or credit shall be the sole remedy available from tekmar, and, without limiting the foregoing in any way, tekmar is not responsible, in contract, tort or strict product liability, for any other losses, costs, expenses, inconveniences, or damages, whether direct, indirect, special, secondary, incidental or consequential, arising from ownership or use of the product, or from defects in workmanship or materials, including any liability for fundamental breach of contract.

This warranty applies only to those products returned to tekmar during the warranty period. This warranty does not cover the cost of the parts or labor to remove or transport the defective product, or to reinstall the repaired or

replacement product. Returned products that are not defective are not covered by this warranty.

This warranty does not apply if the product has been damaged by negligence by persons other than tekmar, accident, fire, Act of God, abuse or misuse; or has been damaged by modifications, alterations or attachments made subsequent to purchase which have not been authorized by tekmar; or if the product was not installed in compliance with tekmar's instructions and the local codes and ordinances; or if due to defective installation of the product; or if the product was not used in compliance with tekmar's instructions.

This warranty is in lieu of all other warranties, express or implied, which the Governing Law (being the law of British Columbia) allows parties to contractually exclude, including, without limitation, warranties of merchantability, fitness for a particular purpose, durability or description of the product, its non-infringement of any relevant patents or trademarks, and its compliance with or non-violation of any applicable environmental, health or safety legislation; the term of any other warranty not hereby contractually excluded is limited such that it shall not extend beyond twenty-four (24) months from the production date, to the extent that such limitation is allowed by the Governing Law.

Product Return Procedure Products that are believed to have defects in workmanship or materials must be returned, together with a written description of the defect, to the tekmar representative for that territory. If the address of the representative is not known, please request it from tekmar at the telephone number listed below.

tekmar[®]
Control Systems

tekmar Control Systems Ltd., Canada
tekmar Control Systems, Inc., U.S.A.
**Head Office: 5100 Silver Star Road
Vernon, B.C. Canada V1B 3K4
Tel. (250) 545-7749 Fax. (250) 545-0650
Web Site: www.tekmarcontrols.com**

