

tekmar® - Application

Universal Reset Control 363

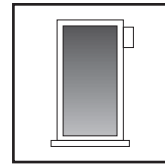

A 363-1
07/99

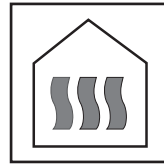
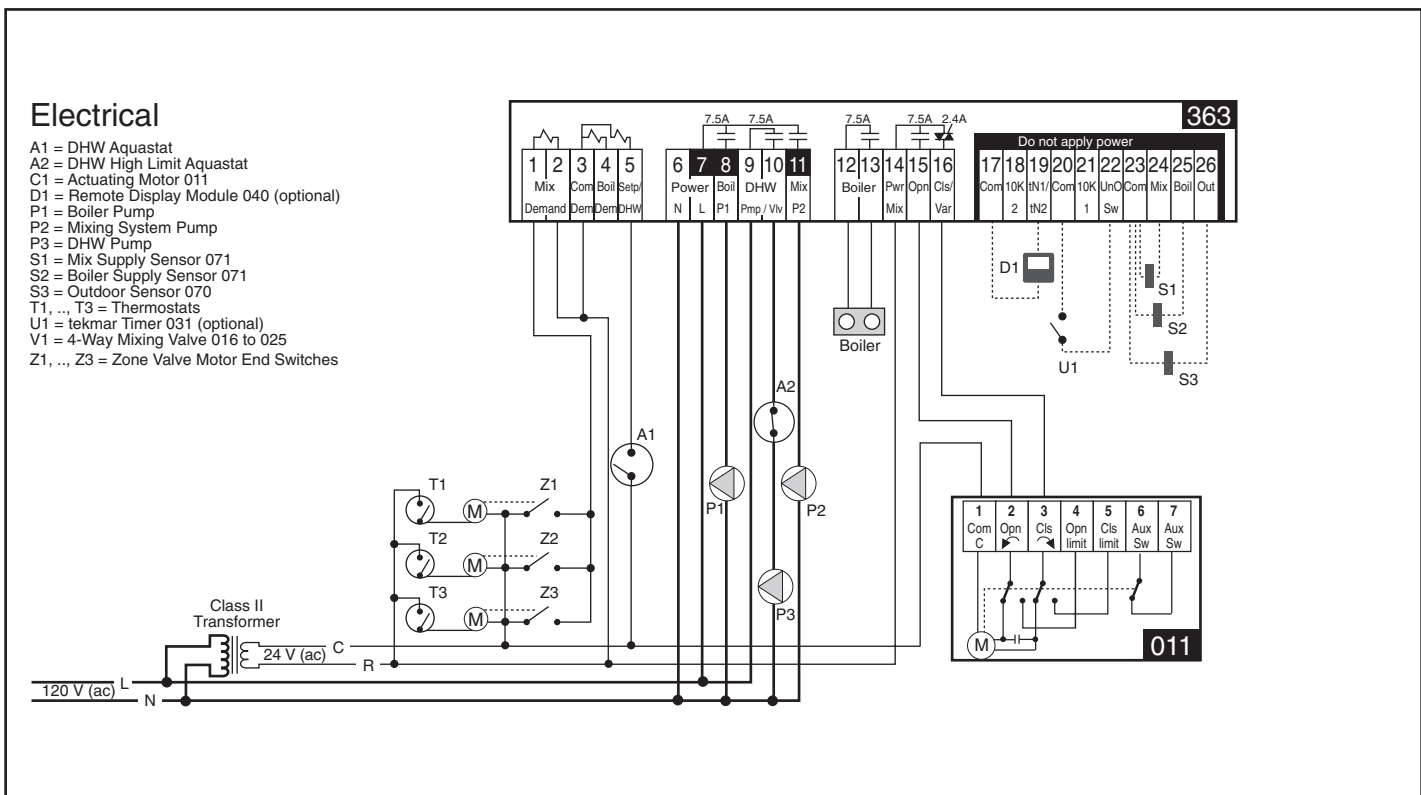
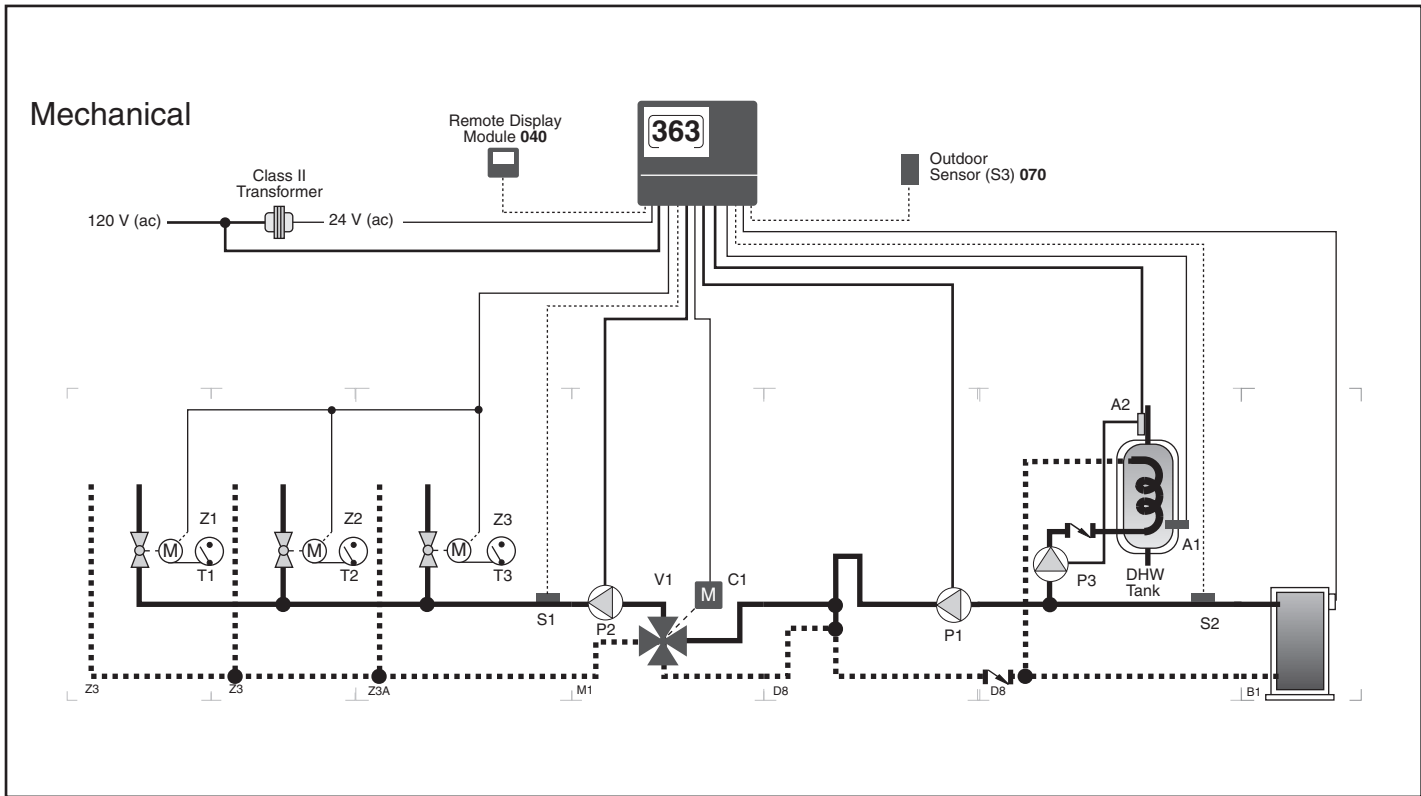

Note: This is only a concept drawing. The designer must determine whether this application will work in his system and must ensure compliance with code requirements. Necessary auxiliary equipment, isolation relays (for loads greater than the specified tekmar internal relay ratings), and other safety and limit devices must be added.

System Operation

The Universal Reset Control 363 provides full outdoor reset to three (or more) mixed zones. The position of the 4-way mixing valve is modulated to mix the water temperature to the zones and protect the boiler from flue gas condensation. The boiler operates at the required temperature in order to satisfy all loads. The 363 also controls the supply of heat to an indirect Domestic Hot Water (DHW) tank. An optional Remote Display Module (RDM) provides remote adjustment and monitoring of the control.

Heat Source Details The heat source can be either a high mass or low mass non-condensing boiler.

Piping Details Thermostat controlled zone valves are piped into the mixed loop. The 4-way mixing valve is piped primary / secondary in order to isolate the boiler loop flow rate from the mixed loop flow rate. Heat is supplied to the DHW tank through a DHW pump (P3). The boiler pump (P1) provides flow through the boiler and ensures flow past the mixing valve take-off.

DHW Demand When the DHW aquastat (A1) calls for heat, the 363 turns on the DHW pump (P3) and raises the boiler water temperature to at least the DHW XCHG temperature setting. The control can provide DHW priority (refer to section C2 of the Data Brochure) by turning off the boiler pump (P1) and closing the mixing valve. Once the DHW demand is removed, the 363 performs a DHW Post Purge.

Mixing Demand When heat is required in the mixed zones, the zone valve end switches send a *Mix Demand* to the 363. The 363 turns on the mixing system pump (P2) and the boiler pump (P1). The mixed supply water temperature is based on the *Reset Ratio* or *Characterized Heating Curve* settings. The 4-way mixing valve is then controlled to supply the required mixed supply water temperature. As the mixing valve opens and requires more heat from the boiler, the boiler is fired to a temperature that is sufficient to satisfy the requirements of the mixing valve. Whenever the boiler is fired, the 363 aims to maintain the boiler temperature above the *Boil MIN* setting. While the boiler is firing, the mixing valve is also modulated to protect the boiler from excessively low water temperatures.

All control functions and specifications are listed in the Product Catalog I 000 and Data Brochure D 363.

Required Material and Essential Control Settings

Required tekmar Products

Universal Reset Control 363
4-way Mixing Valve 016 - 025
Actuator Motor 011

Optional tekmar Products

Remote Display Module (RDM) 040
Timer 031

363 Essential Application Control Settings (Adjust Menu)

<u>Item Field</u>	<u>Setting</u>
MIXING	FLOT (Floating)
MOTR SPD	160 sec
DHW THRU	PUMP

Note For all other settings, refer to the Data Brochure D 363.



tekmar Control Systems Ltd., Canada
tekmar Control Systems, Inc., U.S.A.
Head Office: 5100 Silver Star Road
Vernon, B.C. Canada V1B 3K4
Tel. (250) 545-7749 Fax. (250) 545-0650
Web Site: www.tekmarcontrols.com

Mechanical

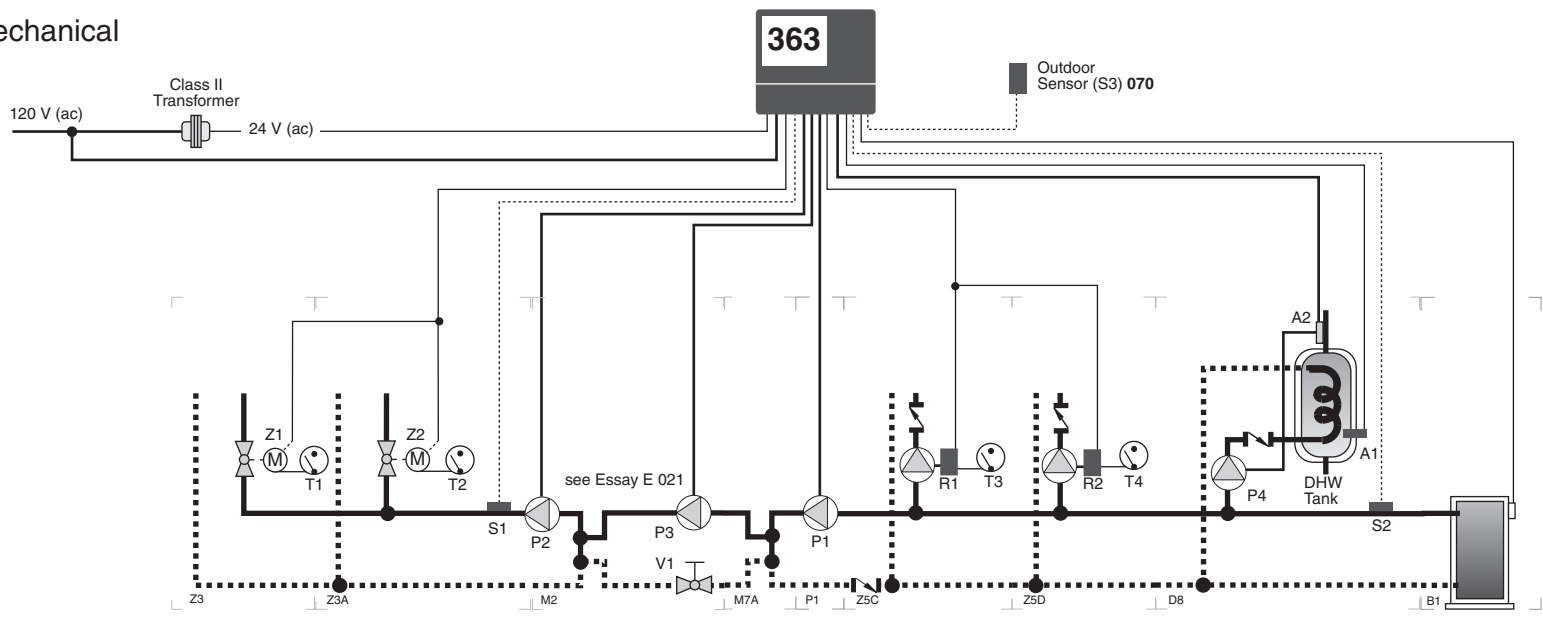

Electrical

- A1 = DHW Aquastat
- A2 = DHW High Limit Aquastat
- P1 = Boiler Pump
- P2 = Mixing System Pump
- P3 = Variable Speed Injection Pump
- P4 = DHW Pump
- R1, R2 = Relay 003
- S1 = Mix Supply Sensor 071
- S2 = Boiler Supply Sensor 071
- S3 = Outdoor Sensor 070
- T1, ... T4 = Thermostats
- U1 = tekmar Timer 031 (optional)
- V1 = Balancing Valve or Globe Valve
- Z1, Z2 = Zone Valve End Switches

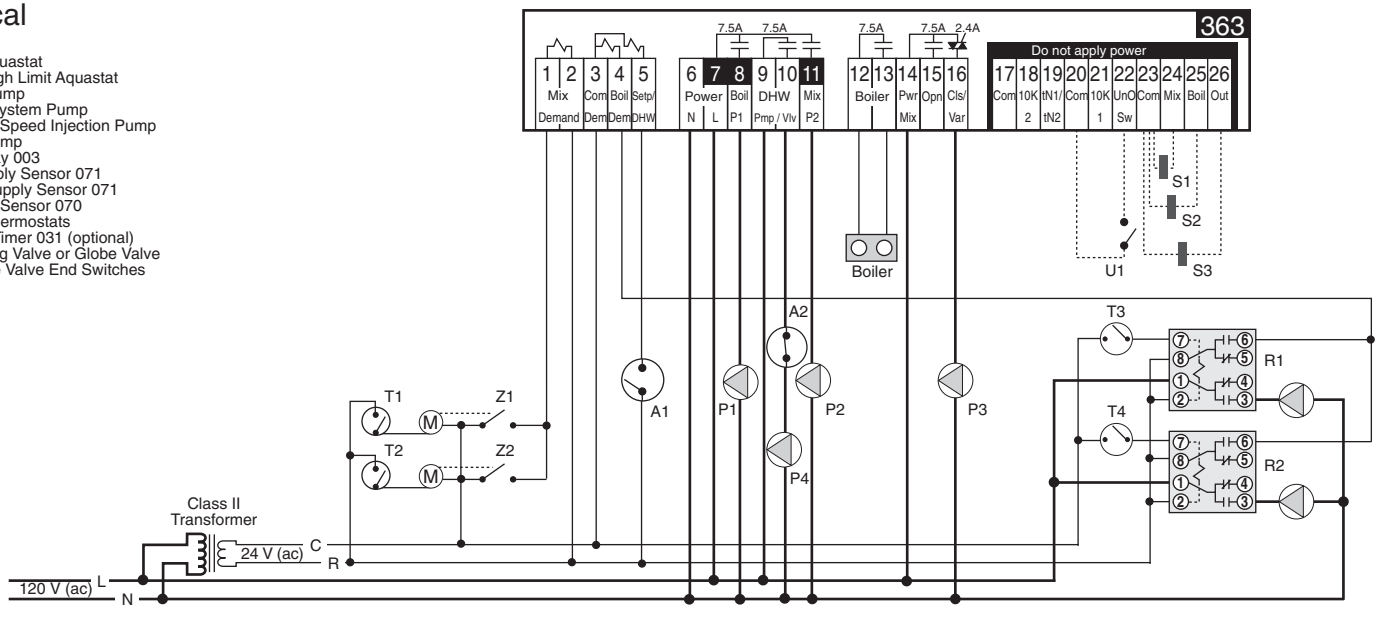

Note: This is only a concept drawing. The designer must determine whether this application will work in his system and must ensure compliance with code requirements. Necessary auxiliary equipment, isolation relays (for loads greater than the specified tekmar internal relay ratings), and other safety and limit devices must be added.

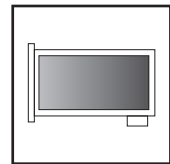
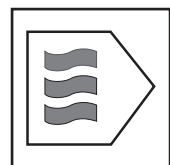

System Operation

The Universal Reset Control 363 provides full outdoor reset to two (or more) mixed zones and partial outdoor reset to two (or more) boiler zones. The output of the variable speed injection pump is modulated to provide a mixed supply water temperature to the mixed zones, and protect the boiler from flue gas condensation. The boiler operates at the required temperature in order to satisfy all loads. The 363 also controls the supply of heat to an indirect Domestic Hot Water (DHW) tank.

Heat Source Details The heat source can be either a high mass or low mass non-condensing boiler.

Piping Details Thermostat controlled zone valves are piped into the mixed loop. The variable speed injection pump (P3) is piped in primary / secondary in order to isolate the boiler loop flow rate from the mixed loop flow rate. Thermostat controlled zone pumps are piped into the boiler loop. Heat is supplied to the DHW tank through a DHW pump (P4). The boiler pump (P1) provides flow through the boiler and ensures flow past the variable speed injection pump take-off.

DHW Demand When the DHW aquastat (A1) calls for heat, the 363 turns on the DHW pump (P4) and raises the boiler water temperature to at least the DHW XCHG temperature setting. The control can provide partial DHW priority (refer to section C2 of the Data Brochure) by ramping down the variable speed injection pump (P3). Once the DHW demand is removed, the 363 performs a DHW Post Purge and possibly a Mixing Purge.

Mixing Demand When heat is required in the mixed zones, the zone valve end switches send a Mix Demand to the 363. The 363 turns on the mixing system pump (P2) and the boiler pump (P1). The mixed supply water temperature is based on the *Reset Ratio* or *Characterized Heating Curve* settings. The variable speed injection pump (P3) is then controlled to supply the required mixed supply water temperature. As the variable speed injection pump ramps up and requires more heat from the boiler, the boiler is fired to a temperature that is sufficient to satisfy the requirements of the variable speed injection pump. Whenever the boiler is fired, the 363 aims to maintain the boiler temperature above the **Boil MIN** setting. While the boiler is firing, the variable speed injection pump is also modulated to protect the boiler from excessively low water temperatures.

Boiler Demand When heat is required in the boiler zones, the zone pump relays send a *Boiler Demand* to the 363. The 363 turns on the boiler pump (P1). The boiler supply water temperature is based on the *Reset Ratio* or *Characterized Heating Curve* settings. The boiler is fired to satisfy the required boiler supply water temperature. Whenever the boiler is fired, the 363 aims to increase the boiler temperature to at least the **Boil MIN** setting.

All control functions and specifications are listed in the Product Catalog I 000 and Data Brochure D 363.

Required Material and Essential Control Settings

Required tekmar Products

Universal Reset Control 363
2 x tekmar DPDT Relay 003

Optional tekmar Products

Timer 031

363 Essential Application Control Settings (Adjust Menu)

<u>Item Field</u>	<u>Setting</u>
MIXING	VAR (Variable Speed)
DHW THRU	PUMP

Note For all other settings, refer to the Data Brochure D 363.

	tekmar Control Systems Ltd., Canada tekmar Control Systems, Inc., U.S.A. Head Office: 5100 Silver Star Road Vernon, B.C. Canada V1B 3K4 Tel. (250) 545-7749 Fax. (250) 545-0650 Web Site: www.tekmarcontrols.com	
---	---	--

Mechanical

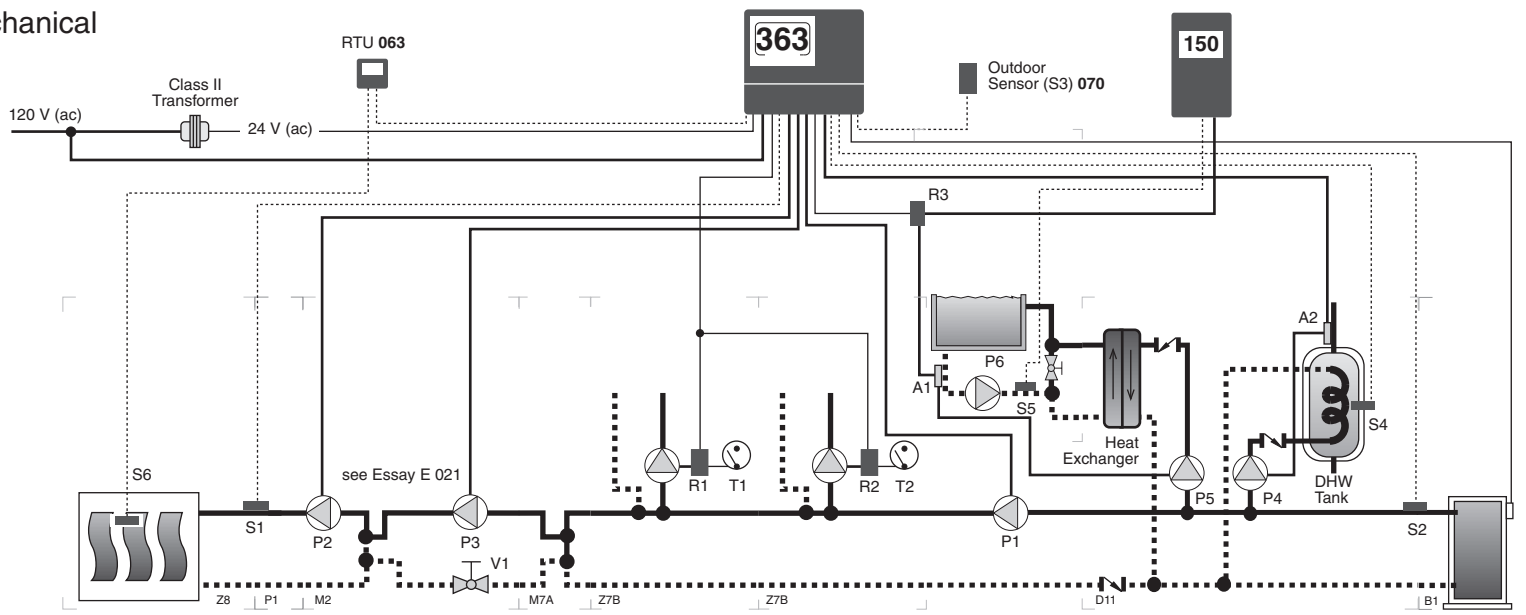

Electrical

- A1 = Pool or Spa High Limit Aquastat
- A2 = DHW High Limit Aquastat
- D1 = RTU 063
- P1 = Boiler Pump
- P2 = Mixing System Pump
- P3 = Variable Speed Injection Pump
- P4 = DHW Pump
- P5 = Heat Exchanger Pump
- P6 = Pool or Spa Pump
- R1, ... R3 = Relay 003
- S1 = Mix Supply Sensor 071
- S2 = Boiler Supply Sensor 071
- S3 = Outdoor Sensor 070
- S4 = DHW Sensor 071
- S5 = Pool or Spa Sensor 071
- S6 = Slab Sensor 072
- T1, T2 = Thermostats
- U1 = tekmarTimer 031(optional)
- V1 = Balancing Valve or Globe Valve

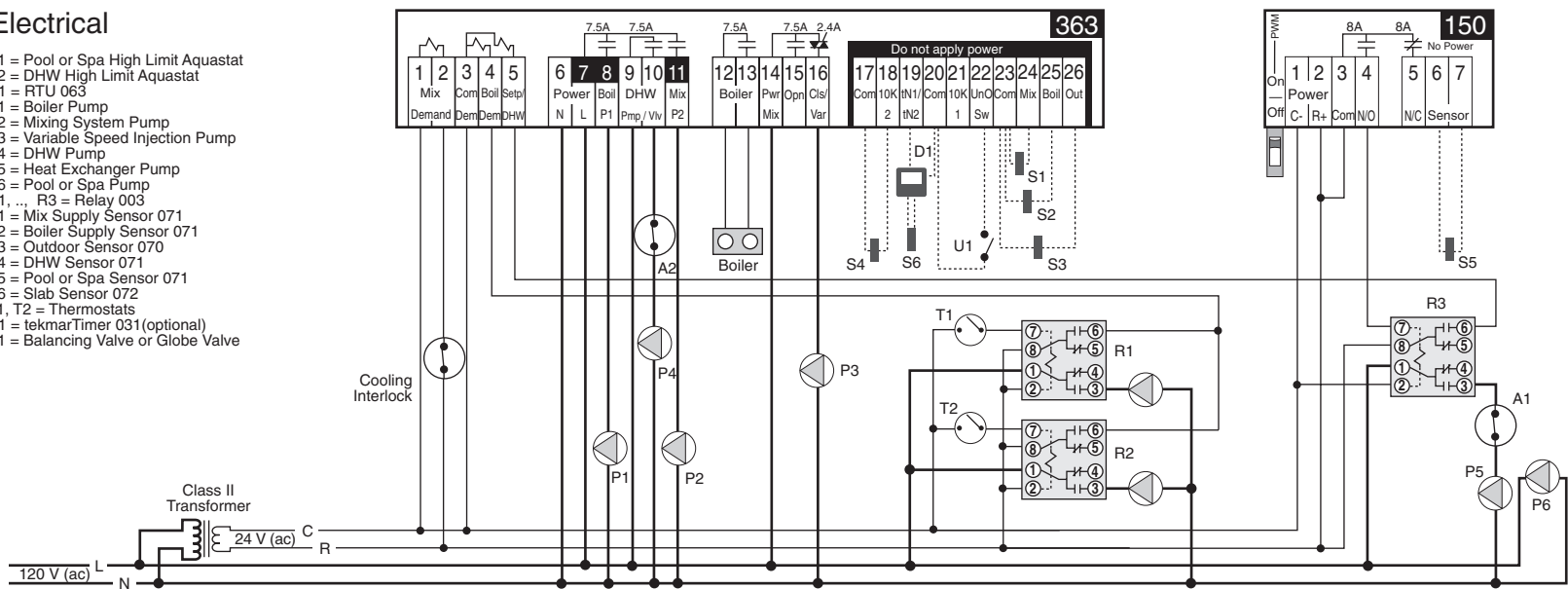

Note: This is only a concept drawing. The designer must determine whether this application will work in his system and must ensure compliance with code requirements. Necessary auxiliary equipment, isolation relays (for loads greater than the specified tekmar internal relay ratings), and other safety and limit devices must be added.

System Operation

The Universal Reset Control 363 provides full outdoor reset to a single mixed zone and partial or full outdoor reset to two (or more) boiler zones. The single mixed zone temperature is controlled through a Room Temperature Unit (RTU) and can be configured for slab or indoor air & slab temperature control. The output of the variable speed injection pump is modulated to provide a mixed supply water temperature to the mixed zone and can protect the boiler from flue gas condensation. The boiler operates at the required temperature to satisfy all loads. The 363 also controls the supply of heat to an indirect Domestic Hot Water (DHW) tank. The Setpoint Control 150 controls the temperature of the pool or spa.

Heat Source Details The heat source can be either a high mass or low mass non-condensing boiler or low temperature boiler. If using a low temperature boiler, refer to section C3 of the Data Brochure for additional information.

Piping Details An RTU controls the single mixed zone using a pump (P2). The variable speed injection pump (P3) is piped primary / secondary in order to isolate the boiler loop flow rate from the mixed loop flow rate. Thermostat controlled zone pumps are also piped primary / secondary into the boiler loop. Heat is supplied to the DHW tank through a DHW pump (P4). The pool or spa is piped into the boiler loop and the temperature is controlled through a heat exchanger pump (P5). The boiler pump (P1) provides flow through the boiler and ensures flow past the variable speed injection pump and boiler zone take-offs.

DHW Demand When the DHW sensor (S4) calls for heat, the 363 turns on the DHW pump (P4) and raises the boiler water temperature to at least the DHW TANK setting plus 40°F (22°C). The control maintains the DHW tank temperature at the DHW TANK setting. The control can provide DHW priority (refer to section C2 and C3 of the Data Brochure) by turning off the boiler pump (P1) and ramping down the variable speed injection pump (P3). Once the DHW demand is removed, the 363 performs a DHW Post Purge and possibly a Mixing Purge.

Setpoint Demand The Setpoint Control 150 cycles relay R3 in order to control the heat exchanger pump (P5) and maintain pool or spa temperature. When the 150 requires heat, it provides a *Setpoint Demand* to the 363 through relay R3. The 363 increases the boiler temperature to at least the SETPOINT setting. The control can provide Setpoint Priority (refer to section C3 and C4 of the Data Brochure) by turning off the boiler pump (P1).

Mixing Demand When heat is required in the mixed zone, the 363 turns on the mixing system pump (P2) and the boiler pump (P1). The mixed supply water temperature is based on the *Characterized Heating Curve* settings as well as the indoor and / or slab temperature feedback that is being received from the RTU. The variable speed injection pump (P3) is then controlled to supply the required mixed supply water temperature. As the variable speed injection pump ramps up and requires more heat from the boiler, the boiler is fired to a temperature that is sufficient to satisfy the requirements of the variable speed injection pump. Whenever the boiler is fired, the 363 aims to maintain the boiler temperature above the Boil MIN setting. While the boiler is firing, the variable speed injection pump is also modulated to protect the boiler from excessively low water temperatures.

Boiler Demand When heat is required in the boiler zones, the zone pump relays send a *Boiler Demand* to the 363. The 363 turns on the boiler pump (P1). The boiler supply water temperature is based on the *Reset Ratio* or *Characterized Heating Curve* settings. The boiler is fired to satisfy the required boiler supply water temperature. Whenever the boiler is fired, the 363 aims to increase the boiler temperature to at least the Boil MIN setting.

Cooling Interlock A cooling interlock is provided for the mixed zone by interrupting power to the *Mix Demand* when the cooling system is in operation. This prevents simultaneous heating and cooling of the mixed zone.

All control functions and specifications are listed in the Product Catalog I 000 and Data Brochure D 363.

Required Material and Essential Control Settings

Required tekmar Products

- Universal Reset Control 363
- One Stage Setpoint Control 150
- Room Temperature Unit (RTU) 063
- Universal Sensor 071
- Slab Sensor 072
- 3 x tekmar DPDT Relay 003

Optional tekmar Products

- Timer 031

363 Essential Application Control Settings (Adjust Menu)

<u>Item Field</u>	<u>Setting</u>
MIXING	VAR (Variable Speed)
IOK 2	DHW
DHW THRU	PUMP

063 Essential Application RTU Settings (Adjust Menu)

<u>Item Field</u>	<u>Setting</u>
REMOT E3	SLAB

Note For all other settings, refer to the Data Brochure D 363, D 150 and D 062.

	tekmar Control Systems Ltd., Canada tekmar Control Systems, Inc., U.S.A. Head Office: 5100 Silver Star Road Vernon, B.C. Canada V1B 3K4 Tel. (250) 545-7749 Fax. (250) 545-0650 Web Site: www.tekmarcontrols.com	
---	---	--

Mechanical

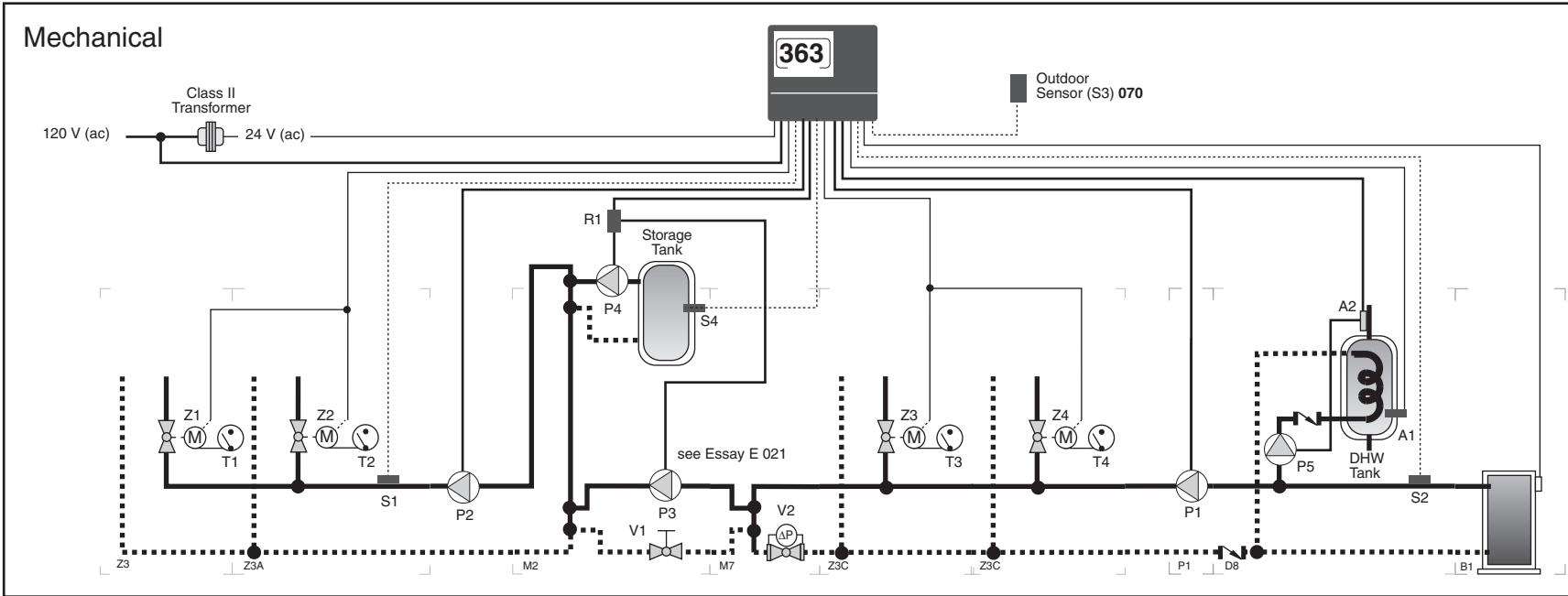

Electrical

- A1 = DHW Aquastat
 - A2 = DHW High Limit Aquastat
 - P1 = Boiler Pump
 - P2 = Mixing System Pump
 - P3, P4 = Variable Speed Injection Pump
 - P5 = DHW Pump
 - R1 = Relay 004
 - S1 = Mix Supply Sensor 071
 - S2 = Boiler Supply Sensor 071
 - S3 = Outdoor Sensor 070
 - S4 = Storage Tank Sensor 071
 - T1, ... T4 = Thermostats
 - U1 = tekmar Timer 031 (optional)
 - V1 = Balancing Valve or Globe Valve
 - V2 = Balancing Valve or Pressure Bypass Valve
 - Z1, ... Z4 = Zone Valve End Switches
- Storage Tank from:
Solar, Off-Peak Electric, Heat Pump, Wood Boiler

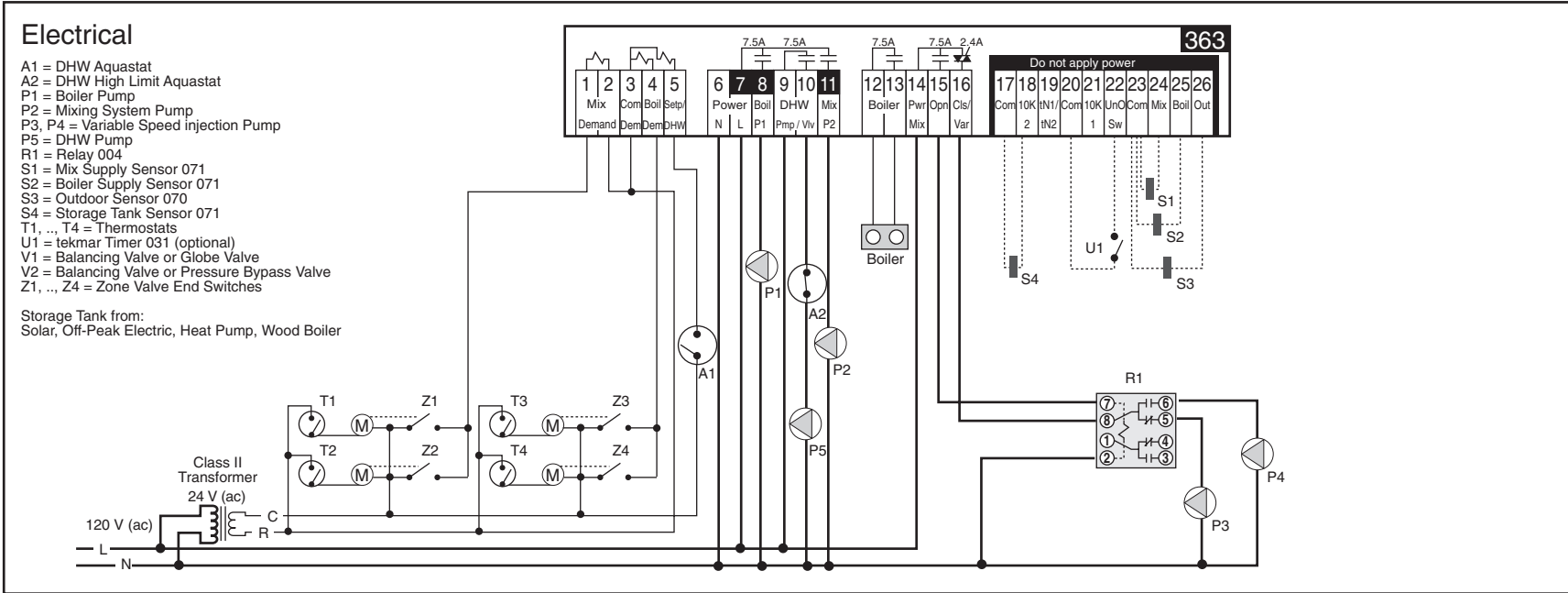

Note: This is only a concept drawing. The designer must determine whether this application will work in his system and must ensure compliance with code requirements. Necessary auxiliary equipment, isolation relays (for loads greater than the specified tekmar internal relay ratings), and other safety and limit devices must be added.

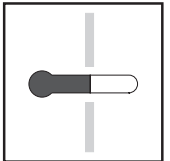
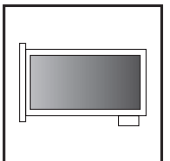
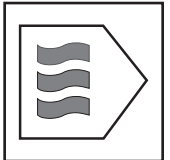

A 363-4
 07/99

System Operation

The Universal Reset Control 363 provides full outdoor reset to two (or more) mixed zones and partial or full outdoor reset to two (or more) boiler zones. If the temperature in the storage tank is hot enough to provide heat to the mixed zones, variable speed injection pump (P4) operates. The 363 operates the variable speed injection pump (P3) if there is not enough heat in the storage tank. The output of either variable speed injection pump is modulated to provide a mixed supply water temperature to the mixed zones. When variable speed injection pump (P3) is operational, it can also protect the boiler from flue gas condensation. The boiler operates at the required temperature in order to satisfy all loads. The 363 also controls the supply of heat to an indirect Domestic Hot Water (DHW) tank.

Heat Source Details The heat source can be either a high mass or low mass non-condensing boiler or low temperature boiler. If using a low temperature boiler, refer to section C3 of the Data Brochure for additional information.

Piping Details Thermostat controlled zone valves are piped into the mixed loop. The variable speed injection pump (P3) injects heat from the boiler loop, or variable speed injection pump (P4) injects heat from the storage tank, into the mixed loop. The variable speed injection pumps are piped primary / secondary in order to isolate the boiler loop flow rate and storage tank from the mixed loop flow rate. Heat is supplied to the DHW tank through a DHW pump (P5). Thermostat controlled zone valves are piped into the boiler loop. The boiler pump (P1) provides flow through the boiler, boiler zones and ensures flow past the variable speed injection pump take-off. A balancing valve (V2) creates a pressure differential so that flow will occur through the boiler zones when those zone valves are open.

DHW Demand When the DHW aquastat (A1) calls for heat, the 363 turns on the DHW pump (P5) and raises the boiler water temperature to at least the DHW XCHG temperature setting. The control can provide DHW priority (refer to sections C2 and C3 of the Data Brochure) by turning off the boiler pump (P1) and ramping down the variable speed injection pump (P3). Once the DHW demand is removed, the 363 performs a DHW Post Purge and possibly a Mixing Purge.

Mixing Demand When heat is required in the mixed zones, the zone valve end switches send a *Mix Demand* to the 363. The 363 turns on the mixing system pump (P2). The mixed supply water temperature is based on *Reset Ratio* or *Characterized Heating Curve* settings. If the storage tank is hot enough as measured by the storage tank sensor (S4), the storage tank variable speed injection pump (P4) injects heat into the mixed loop. If the storage tank temperature is not hot enough, then the 363 turns on the boiler pump (P1) and the variable speed injection pump (P3) injects heat into the mixed loop. The selected variable speed injection pump is then controlled to supply the required mixed supply water temperature. As the boiler variable speed injection pump (P3) ramps up, and requires more heat from the boiler, the boiler is fired to a temperature that is sufficient to satisfy the requirements of the boiler variable speed injection pump. Whenever the boiler is fired, the 363 aims to maintain the boiler temperature above the *Boil MIN* setting. While the boiler is firing, the variable speed injection pump (P3) is also modulated to protect the boiler from excessively low water temperatures.

Boiler Demand When heat is required in the boiler zones, the zone valve end switches send a *Boiler Demand* signal to the 363. The 363 turns on the boiler pump (P1). The boiler supply water temperature is based on *Reset Ratio* or *Characterized Heating Curve* settings. The boiler is fired to satisfy the required boiler supply water temperature. Whenever the boiler is fired, the 363 aims to increase the boiler temperature to at least the *Boil MIN* setting.

All control functions and specifications are listed in the Product Catalog I 000 and Data Brochure D 363.

Required Material and Essential Control Settings

Required tekmar Products

Universal Reset Control 363
 Universal Sensor 071
 1 x tekmar DPDT Relay 004

Optional tekmar Products

Timer 031

363 Essential Application Control Settings (Adjust Menu)

Item Field	Setting
MIXING	STOR (Storage)
10K 2	STOR
DHW THRU	PUMP

Note For all other settings, refer to the Data Brochure D 363.



tekmar Control Systems Ltd., Canada
 tekmar Control Systems, Inc., U.S.A.
Head Office: 5100 Silver Star Road
Vernon, B.C. Canada V1B 3K4
Tel. (250) 545-7749 Fax. (250) 545-0650
Web Site: www.tekmarcontrols.com

tekmar® - Application

Universal Reset Control 363 & Mixing Control 362



A 363-5

07/99

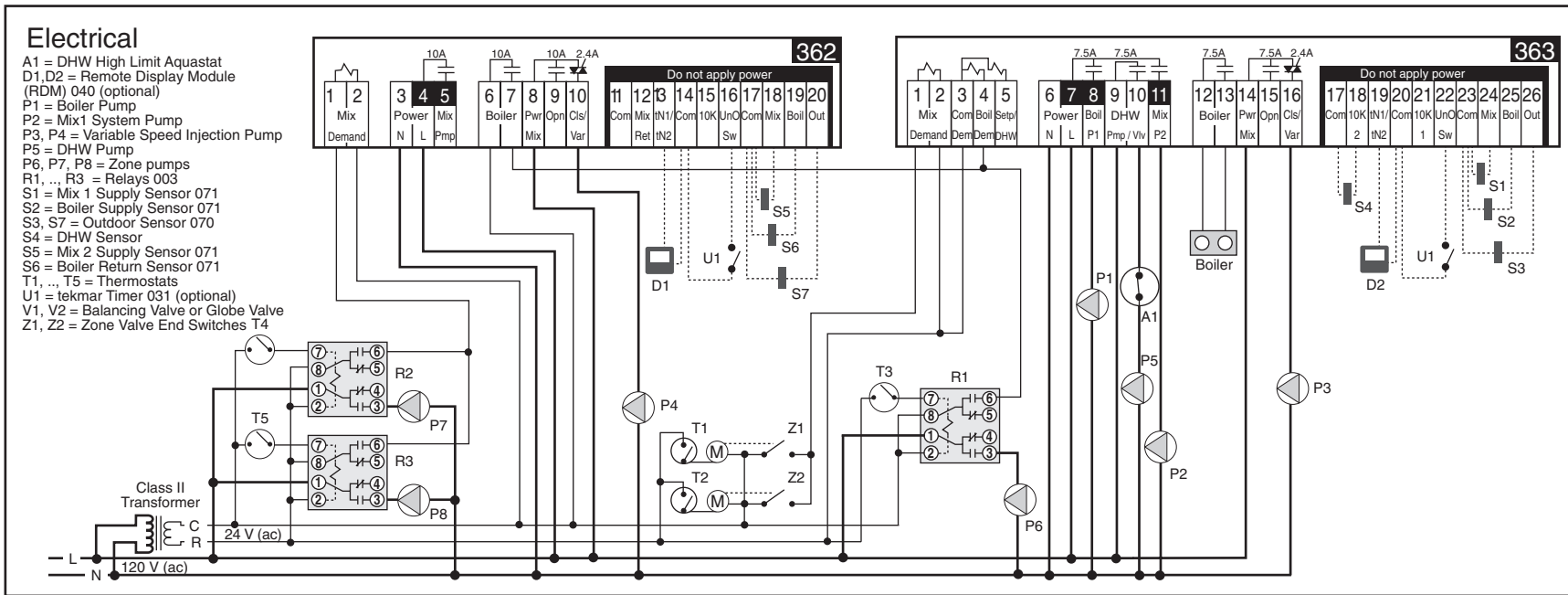
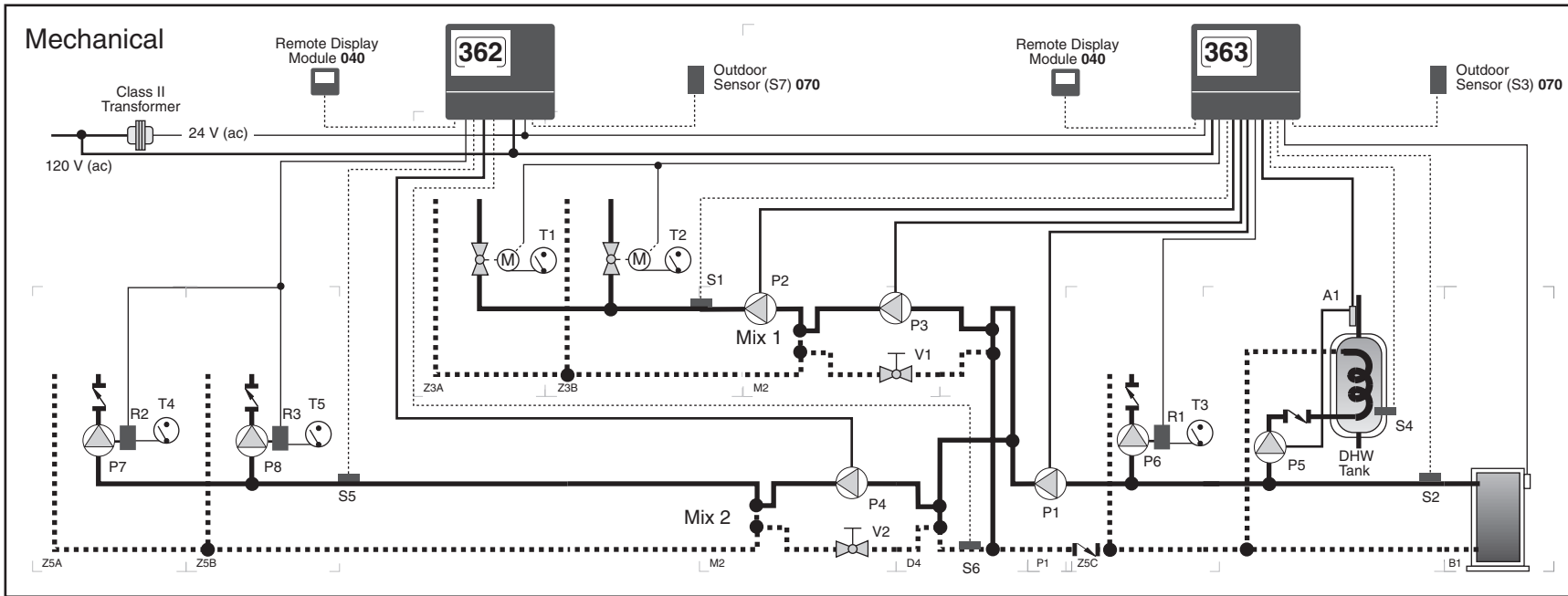

Note: This is only a concept drawing. The designer must determine whether this application will work in his system and must ensure compliance with code requirements. Necessary auxiliary equipment, isolation relays (for loads greater than the specified tekmar internal relay ratings), and other safety and limit devices must be added.

System Operation

The Universal Reset Control 363 and the Mixing Control 362 combine to provide full outdoor reset to two independent mixed temperatures and partial outdoor reset to a boiler zone. The output of the variable speed injection pumps are modulated to provide a mixed supply water temperature to the mixed zones and protect the boiler from flue gas condensation. The boiler operates at the required temperature in order to satisfy all loads. The 363 also controls the supply of heat to an indirect Domestic Hot Water (DHW) tank. Two optional Remote Display Modules (RDM's) provide remote adjustment and monitoring of the controls.

Heat Source Details The heat source can be either a high mass or low mass non-condensing boiler.

Piping Details Thermostat controlled zone valves are piped in to the first mixed loop (Mix 1). Thermostat controlled zone pumps are piped into the second mixed loop (Mix 2). A thermostat controlled zone pump (P6) is piped into the boiler loop. The variable speed injection pumps are piped in primary / secondary in order to isolate the boiler loop flow rate from the mixed loop flow rates. Heat is supplied to the DHW tank through a DHW pump (P5). The boiler pump (P1) provides flow through the boiler and ensures flow past the variable speed injection pump take-offs.

DHW Demand When the DHW sensor (S4) calls for heat, the 363 turns on the DHW pump (P5) and raises the boiler water temperature to at least the DHW TANK setting plus 40°F (22°C). The control maintains the DHW tank temperature at the DHW TANK setting. The control can provide partial DHW priority by turning off the boiler pump (P1) and ramping down the Mix 1 variable speed injection pump (P3). Once the DHW demand is removed, the 363 performs a DHW Post Purge and possibly a Mixing Purge.

Mixing Demand (Mix 1) When heat is required in the Mix 1 zones, the zone valve end switches send a *Mix Demand* to the 363. The 363 turns on the mix pump (P2) and the boiler pump (P1). The mixed supply water temperature is based on *Reset Ratio* or *Characterized Heating Curve* settings. The variable speed injection pump (P3) is then controlled to supply the required mixed supply water temperature. As the variable speed injection pump ramps up and requires more heat from the boiler, the boiler is fired to a temperature that is sufficient to satisfy the requirements of the variable speed injection pump. Whenever the boiler is fired, the 363 aims to maintain the boiler temperature above the Boil MIN setting. While the boiler is firing, the variable speed injection pump is also modulated to protect the boiler from excessively low water temperatures.

Mixing Demand (MIX 2) When heat is required in the Mix 2 zones, the zone pump relays send a *Mix Demand* to the 362. The mixed supply water temperature is based on *Reset Ratio* or *Characterized Heating Curve* settings. The variable speed injection pump (P4) is then controlled to supply the required mixed supply water temperature. As the variable speed injection pump ramps up, the 362 uses its *Boiler* contact (terminals 6 and 7) to send a *Boiler Demand* to the 363. While the 362 is sending a *Boiler Demand* to the 363, the variable speed injection pump (P4) is also modulated to protect the boiler from excessively low water temperatures.

Boiler Demand When heat is required in the boiler zone, the zone pump relay sends a *Boiler Demand* to the 363. Also, if Mix 2 requires heat the 362 uses its *Boiler* contact (terminals 6 and 7) to send a *Boiler Demand* to the 363. The 363 turns on the boiler pump (P1). The boiler supply water temperature is based on the *Reset Ratio* or *Characterized Heating Curve* settings. The boiler is fired to satisfy the required boiler supply water temperature. Whenever the boiler is fired, the 363 aims to increase the boiler temperature to at least the Boil MIN setting.

All control functions and specifications are listed in the Product Catalog I 000 Data Brochures D 362 and D 363.

Required Material and Essential Control Settings

Required tekmar Products

Mixing Control 362
 Universal Reset Control 363
 Universal Sensor 071 (DHW Tank)
 3 x tekmar DPDT Relay 003

362 Essential Application Control Settings (Adjust Menu)

Item Field	Setting
MODE	-1-
MIXING	VAR
Boil SENS	RET
Boil MIN	20°F (11°C) less than Boil MIN on 363

Optional tekmar Products

2 x Remote Display Module (RDM) 040
 Timer 031

363 Essential Application RTU Settings (Adjust Menu)

Item Field	Setting
MIXING	VAR
DHW THRU	PUMP
IDK 2	DHW

Note For all other settings, refer to the Data Brochure D 362 or D 363.



tekmar Control Systems Ltd., Canada
 tekmar Control Systems, Inc., U.S.A.
Head Office: 5100 Silver Star Road
Vernon, B.C. Canada V1B 3K4
Tel. (250) 545-7749 Fax. (250) 545-0650
Web Site: www.tekmarcontrols.com

tekmar® - Application

Universal Reset Control 363 & Zone Control 368

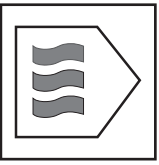

A 363-6
07/99

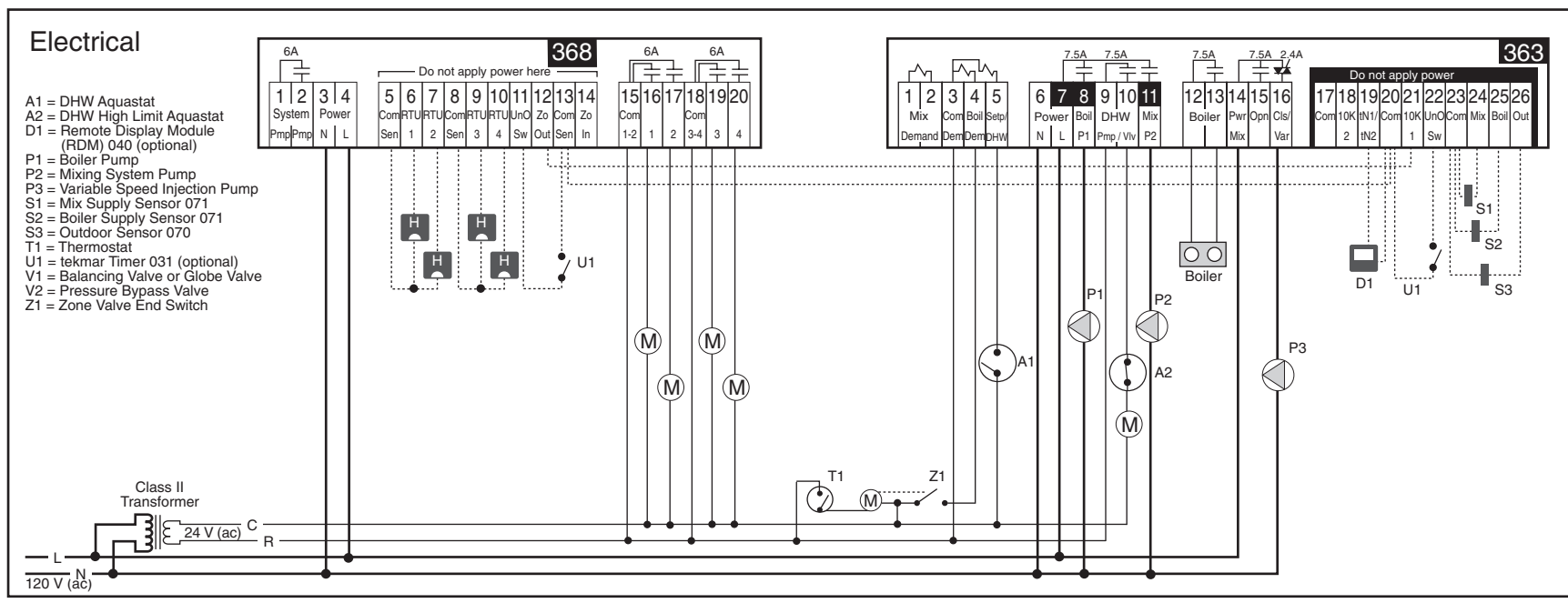
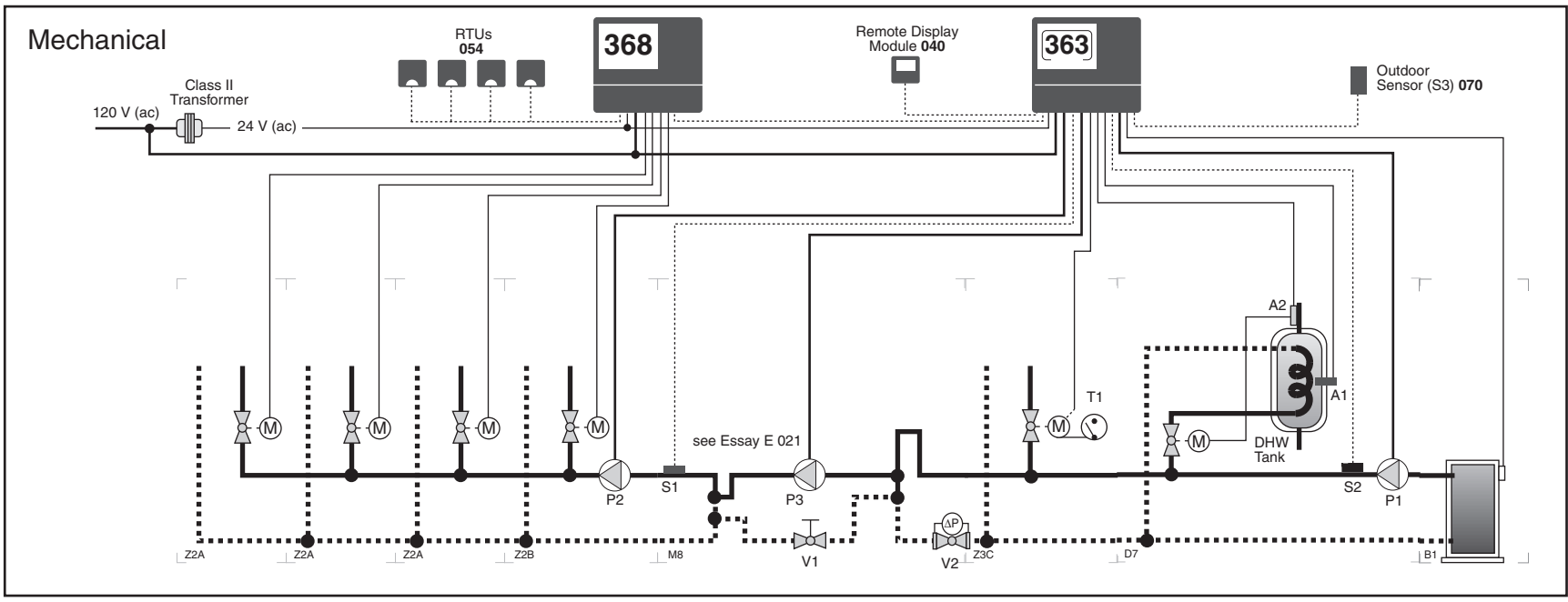

Note: This is only a concept drawing. The designer must determine whether this application will work in his system and must ensure compliance with code requirements. Necessary auxiliary equipment, isolation relays (for loads greater than the specified tekmar internal relay ratings), and other safety and limit devices must be added.

System Operation

The Universal Reset Control 363 and the Zone Control 368 combine to provide full outdoor reset to four mixed zones, and partial outdoor reset to one (or more) boiler zones. The output of the variable speed injection pump is modulated to mix down the boiler supply water temperature to the mixed zones and protect the boiler from flue gas condensation. The boiler operates at the required temperature in order to satisfy all loads. The 363 also controls the supply of heat to an indirect Domestic Hot Water (DHW) tank.

Heat Source Details The heat source can be either a high mass or low mass non-condensing boiler.

Piping Details Room Temperature Unit (RTU) controlled zone valves are piped into the mixed loop. A thermostat controlled zone valve is piped into the boiler loop. The variable speed injection pump is piped primary / secondary in order to isolate the boiler loop flow rate from the mixed loop flow rate. Heat is supplied to the DHW tank through a DHW valve. The boiler pump (P1) provides flow through the boiler, DHW tank, boiler zone, and ensures flow past the variable speed injection pump take-off. A pressure bypass valve (V2) creates a pressure differential so that flow will occur through the boiler zone and DHW tank when those valves are open.

Heating Zones The air temperatures in the mixed zones are controlled using RTU's. The Zone Control 368 uses PID (proportional, integral, derivative) air temperature control and synchronizes the operation of the zones to provide more even loading of the mixed system. The 368 uses its Zo Out terminal to send an internal *Mix Demand* to the 363 when the mixed zones require heat. The same Zo Out terminal provides an indoor temperature feedback signal from the 368 to the 363. This signal allows the 363 to provide more accurate control of the mixed supply water temperature.

DHW Demand When the DHW aquastat (A1) calls for heat, the 363 turns on the DHW pump (P4) and raises the boiler water temperature to at least the DHW XCHG temperature setting. The control can provide partial DHW priority (refer to section C2 of the Data Brochure) by turning off the boiler pump (P1) and ramping down the variable speed injection pump (P3). Once the DHW demand is removed, the 363 performs a DHW Post Purge and possibly a Mixing Purge.

Mixing Demand When heat is required in the mixed zones, the Zone Control 368 provides an internal *Mix Demand* (through the Zo Out / 10K 1 connection) to the 363. The 363 turns on the mix pump (P2) and the boiler pump (P1). The mix supply water temperature is based on the *Characterized Heating Curve* settings and indoor temperature feedback from the Zone Control 368. The variable speed injection pump (P3) is then controlled to supply the required mixed supply water temperature. As the variable speed injection pump ramps up and requires more heat from the boiler, the boiler is fired to a temperature that is sufficient to satisfy the requirements of the variable speed injection pump. Whenever the boiler is fired, the 363 aims to maintain the boiler temperature above the Boil MIN setting. While the boiler is firing, the variable speed injection pump is also modulated to protect the boiler from excessively low water temperatures.

Boiler Demand When heat is required in the boiler zone, the zone valve end switch sends a *Boiler Demand* to the 363. The 363 turns on the boiler pump (P1). The boiler supply water temperature is based on the *Reset Ratio* or *Characterized Heating Curve* settings. The boiler is fired to satisfy the required boiler supply water temperature. Whenever the boiler is fired, the 363 aims to increase the boiler temperature to at least the Boil MIN setting.

All control functions and specifications are listed in the Product Catalog I 000 and Data Brochure D 363 & D 368.

Required Material and Essential Control Settings

Required tekmar Products

Universal Reset Control 363
 Zone Control 368
 4 x Room Temperature Unit (RTU) 054/055
 tekmar DPDT Relay 003

363 Essential Application Control Settings (Adjust Menu)

Item Field	Setting
10K 1	MIX
MIXING	VAR
DHW THRU	PUMP

Note For all other settings, refer to the Data Brochure D 363.

Optional tekmar Products

Remote Display Module (RDM) 040
 Timer 031



tekmar Control Systems Ltd., Canada
 tekmar Control Systems, Inc., U.S.A.
Head Office: 5100 Silver Star Road
Vernon, B.C. Canada V1B 3K4
Tel. (250) 545-7749 Fax. (250) 545-0650
Web Site: www.tekmarcontrols.com