

Mechanical

MODE -1-

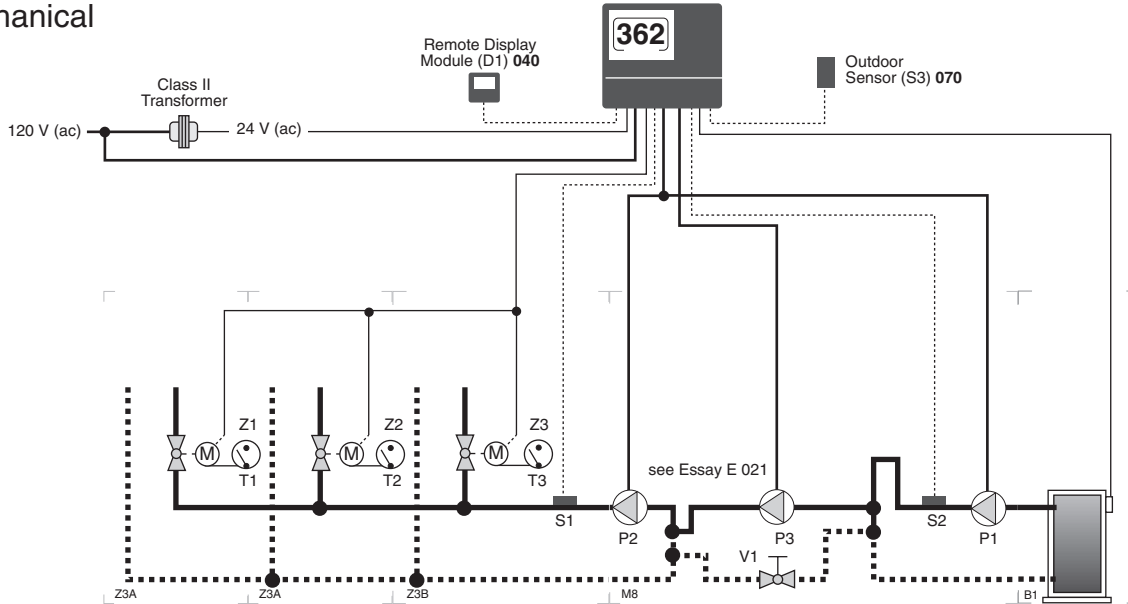

Electrical

- D1 = Remote Display Module 040 (optional)
- P1 = Boiler Pump
- P2 = Mixing System Pump
- P3 = Variable Speed Injection Pump
- S1 = Mix Supply Sensor 071
- S2 = Boiler Supply Sensor 071
- S3 = Outdoor Sensor 070
- T1, ... T3 = Thermostats
- U1 = tekmar Timer 031 (optional)
- V1 = Balancing Valve or Globe Valve
- Z1, ... Z3 = Zone Valve Motor End Switches

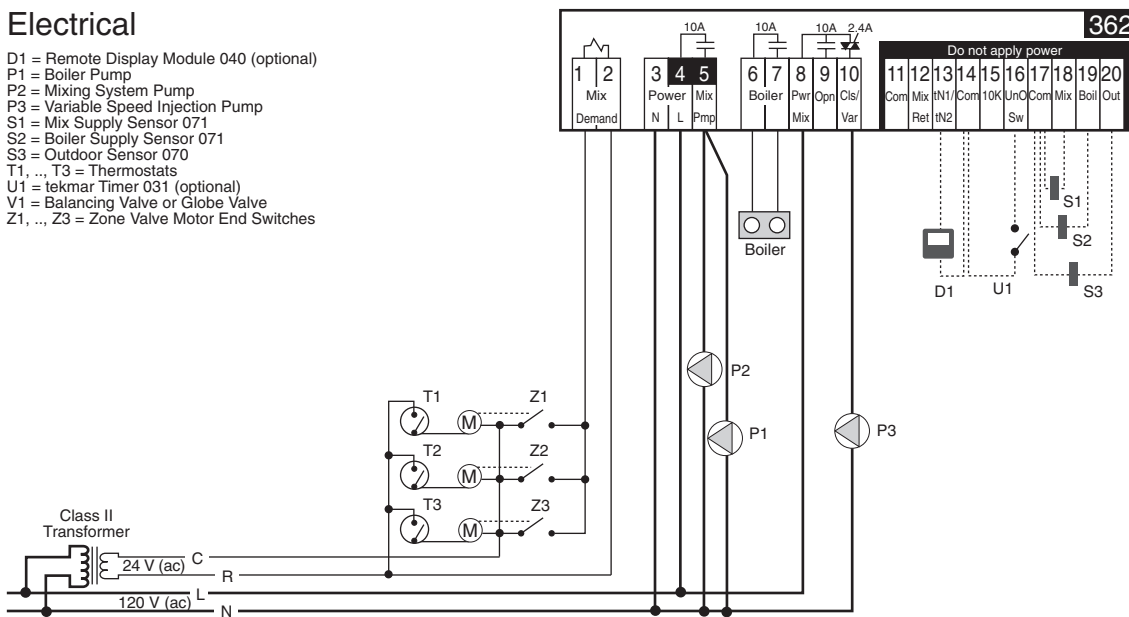

Note: This is only a concept drawing. The designer must determine whether this application will work in his system and must ensure compliance with code requirements. Necessary auxiliary equipment, isolation relays (for loads greater than the specified tekmar internal relay ratings), and other safety and limit devices must be added.

System Operation

The Mixing Control 362 provides full outdoor reset to three (or more) mixed zones. The output of the variable speed injection pump is modulated to mix the water temperature to the zones and protect the boiler from flue gas condensation. The boiler operates at the required temperature in order to satisfy the load. An optional Remote Display Module (RDM) provides remote adjustment and monitoring.

Heat Source Details The heat source can be either a high mass or low mass non-condensing boiler.

Piping Details Thermostat controlled zone valves are piped into the mixed loop. The variable speed injection pump (P3) is piped in primary / secondary in order to isolate the boiler loop flow rate from the mixed loop flow rate. The boiler pump (P1) provides flow through the boiler and ensures flow past the variable speed injection pump take-off.

Mixing Demand When heat is required in the mixed zones, the zone valve end switches send a *Mix Demand* to the 362. The 362 turns on the mixing system pump (P2) and the boiler pump (P1). The mixed supply water temperature is based on the *Reset Ratio or Characterized Heating Curve* settings. The variable speed injection pump (P3) is then controlled to supply the required mixed supply water temperature. As the variable speed injection pump ramps up and requires more heat from the boiler, the boiler is fired to a temperature that is sufficient to satisfy the requirements of the variable speed injection pump. Whenever the boiler is fired, the 362 aims to maintain the boiler temperature above the *Boil MIN* setting. While the boiler is firing, the variable speed injection pump is also modulated to protect the boiler from excessively low water temperatures.

All control functions and specifications are listed in the Product Catalog I 000 and Data Brochure D 362.

Required Material and Essential Control Settings

Required tekmar Products

Universal Reset Control 362

Optional tekmar Products

Remote Display Module (RDM) 040
Timer 031

362 Essential Application Control Settings (Adjust Menu)

<u>Item Field</u>	<u>Setting</u>
MODE	-I-
MIXING	VAR

Note For all other settings, refer to the Data Brochure D 362.



tekmar Control Systems Ltd., Canada
tekmar Control Systems, Inc., U.S.A.
Head Office: 5100 Silver Star Road
Vernon, B.C. Canada V1B 3K4
Tel. (250) 545-7749 Fax. (250) 545-0650
Web Site: www.tekmarcontrols.com



Mechanical

MODE -1-

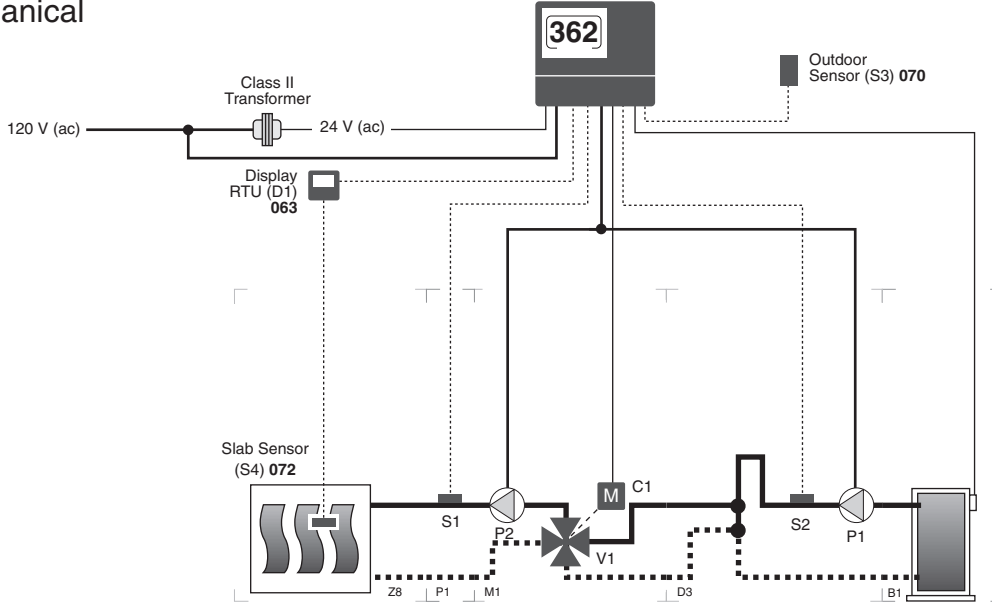

Electrical

- C1 = Actuating Motor 011
- D1 = RTU 063
- P1 = Boiler Pump
- P2 = Mixing System Pump
- R1 = Relay 003
- S1 = Mix Supply Sensor 071
- S2 = Boiler Supply Sensor 071
- S3 = Outdoor Sensor 070
- S4 = Slab Sensor 072 or 073
- U1 = tekmar Timer 031 (optional)
- V1 = 4-Way Mixing Valve 016-025

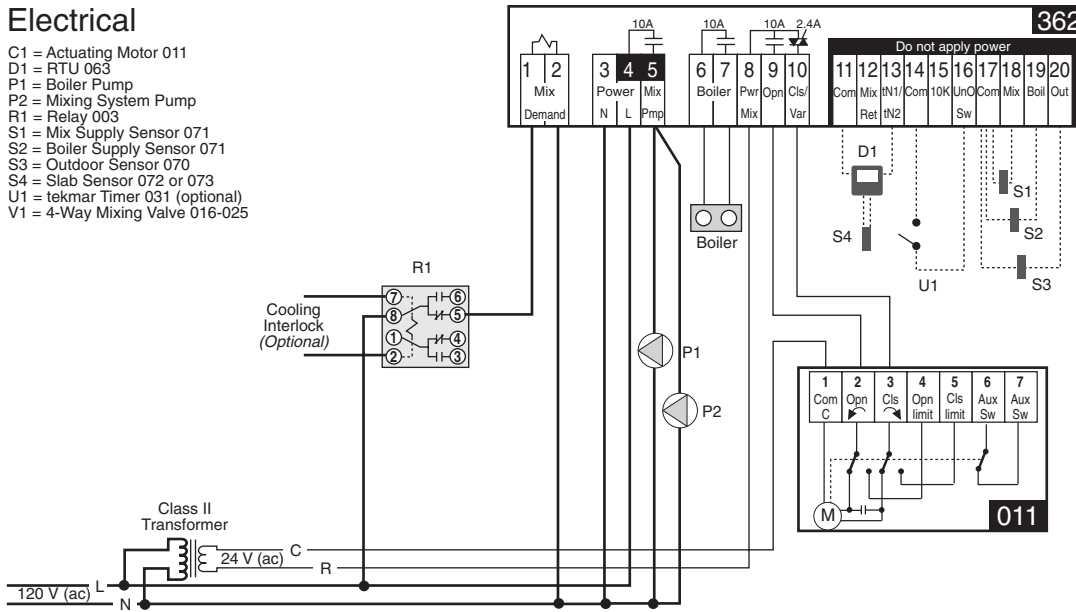

Note: This is only a concept drawing. The designer must determine whether this application will work in his system and must ensure compliance with code requirements. Necessary auxiliary equipment, isolation relays (for loads greater than the specified tekmar internal relay ratings), and other safety and limit devices must be added.

System Operation

The Mixing Control 362 provides full outdoor reset to a single mixed zone. The single mixed zone temperature is controlled through a Room Temperature Unit (RTU) 063 and can be configured for slab or indoor air and slab temperature control. The position of the mixing valve is modulated to provide a mixed supply water temperature to the mixed zone and to protect the boiler from flue gas condensation.

Heat Source Details The heat source can be either a high mass or low mass non-condensing boiler.

Piping Details The mixing valve is piped primary / secondary in order to isolate the boiler loop flow rate from the mixed loop flow rate. The boiler pump (P1) provides flow through the boiler and ensures flow past the mixing valve take-off.

Mixing Operation When heat is required in the mixed zone, the 362 turns on the mixing system pump (P2) and the boiler pump (P1). The mixed supply water temperature is based on the *Characterized Heating Curve* settings. The mixing valve is then modulated to supply the required mixed supply water temperature. As the mixing valve opens and requires more heat from the boiler, the boiler is fired to a temperature that is sufficient to satisfy the requirements of the mixing valve. Whenever the boiler is fired, the 362 aims to maintain the boiler temperature above the **Boil MIN** setting. While the boiler is firing, the mixing valve is also modulated to protect the boiler from excessively low water temperatures.

Cooling Interlock A cooling interlock is provided for the mixed zone by interrupting power to the *Mix Demand* when the cooling system is in operation. This prevents simultaneous heating and cooling of the mixed zone.

All control functions and specifications are listed in the Product Catalog I 000 and Data Brochure D 362.

Required Material and Essential Control Settings

Required tekmar Products

Universal Reset Control 362
 Room Temperature Unit (RTU) 063
 Slab Sensor 072 or 073
 tekmar Mixing Valve 016 to 025
 tekmar Actuator Motor 011
 1 x tekmar Relay 004

362 Essential Application Control Settings (Adjust Menu)

Item Field	Setting
MODE	-I-
MIXING	FLOT
MOTOR SPD	160 sec

Note For all other settings, refer to the Data Brochure D 362.

Optional tekmar Products

Timer 031



tekmar Control Systems Ltd., Canada
 tekmar Control Systems, Inc., U.S.A.
Head Office: 5100 Silver Star Road
Vernon, B.C. Canada V1B 3K4
Tel. (250) 545-7749 Fax. (250) 545-0650
Web Site: www.tekmarcontrols.com

tekmar® - Application

Mixing Control 362 & Mixing Control 362

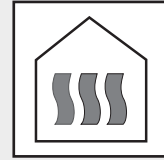

A 362-3

07/99

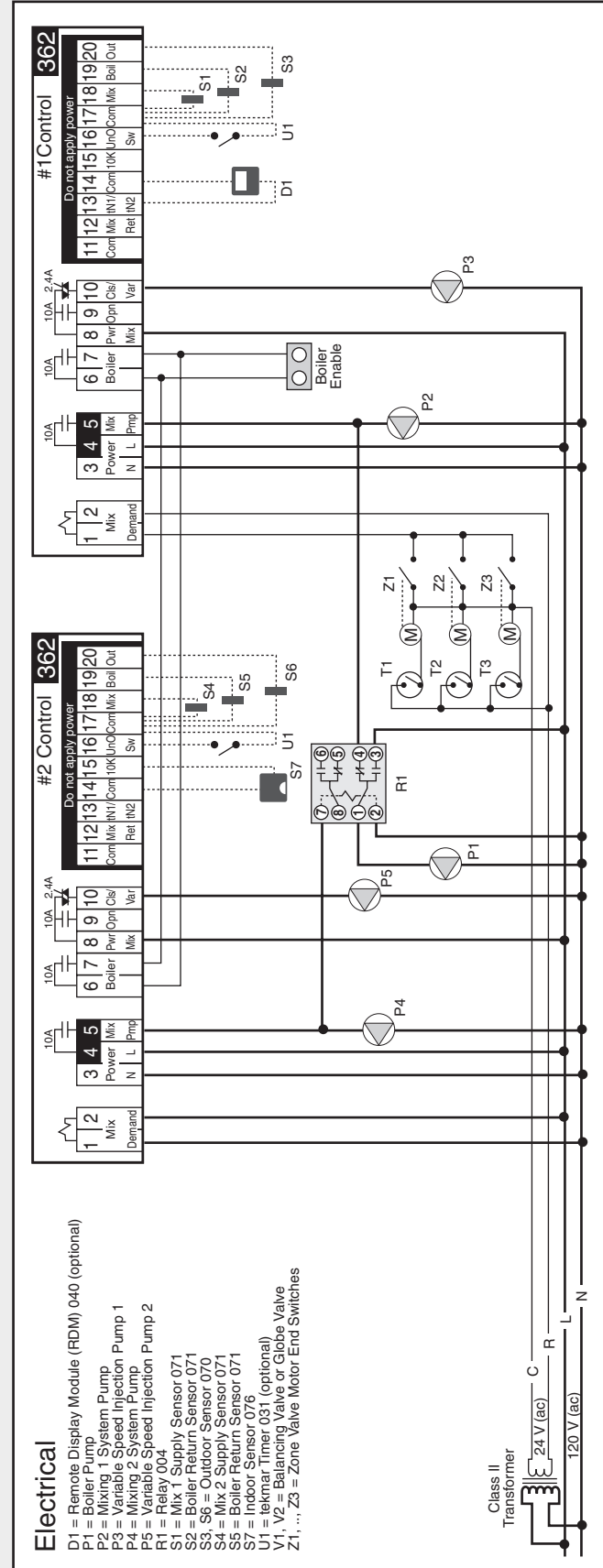
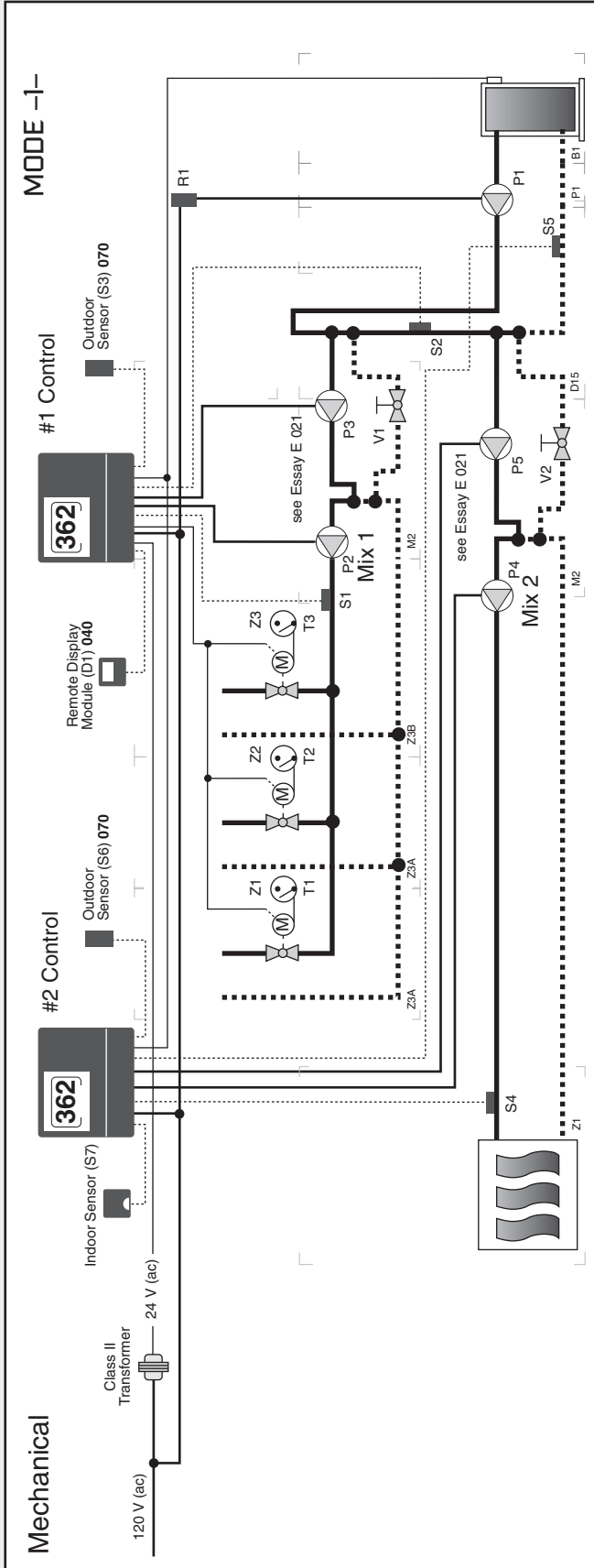

- D1 = Remote Display Module (RDM) 040 (optional)
- P1 = Boiler Pump
- P2 = Mixing 1 System Pump
- P3 = Variable Speed Injection Pump 1
- P4 = Mixing 2 System Pump
- P5 = Variable Speed Injection Pump 2
- R1 = Relay 004
- S1 = Mix 1 Supply Sensor 071
- S2 = Boiler Return Sensor 071
- S3, S6 = Outdoor Sensor 070
- S4 = Mix 2 Supply Sensor 071
- S5 = Boiler Return Sensor 071
- S7 = Indoor Sensor 076
- U1 = tekmar Timer 031 (optional)
- V1, V2 = Balancing Valve or Globe Valve
- Z1, ..., Z3 = Zone Valve Motor End Switches

Note: This is only a concept drawing. The designer must determine whether this application will work in his system and must ensure compliance with code requirements. Necessary auxiliary equipment, isolation relays (for loads greater than the specified tekmar internal relay ratings), and other safety and limit devices must be added.

System Operation

Two Mixing Control 362's provide full outdoor reset to two independent mixed temperatures. The outputs of the variable speed injection pumps are modulated to provide a mixed supply water temperature to the mixed zones and protect the boiler from flue gas condensation. The boiler operates at its operating aquastat temperature. An optional Remote Display Module (RDM) connected to one of the 362's provides remote adjustment and monitoring for that control.

Heat Source Details The heat source can be either a high mass or low mass non-condensing boiler. The boiler's aquastat must be set at least 20°F (11°C) hotter than the **Boil MIN** setting on either 362. For a non-condensing boiler, the minimum boiler return temperature desired (**Boil MIN**) is typically 135°F (57°C), therefore the boiler's aquastat should be set hotter than 155°F (68°C).

Piping Details Thermostat controlled zone valves are piped into the first mixed loop (Mix 1). A single mixed zone is controlled through an Indoor Sensor in the second mixed loop (Mix 2). The variable speed injection pumps are piped in primary / secondary in order to isolate the boiler loop flow rate from the flow rates of the mixed loops. The boiler pump (P1) provides flow through the boiler and ensures flow past the variable speed injection pump take-offs.

Mixing Demand (Mix 1) When heat is required in the Mix 1 zones, the zone valve end switches send a *Mix Demand* to the 362. The 362 turns on the mixing system pump (P2) and the boiler pump (P1). The mixed supply water temperature is based on the *Reset Ratio* or *Characterized Heating Curve* settings. The variable speed injection pump (P3) is then controlled to supply the required mixed supply water temperature. As the variable speed injection pump ramps up, the 362 uses its *Boiler* contact (terminals 6 and 7) to send a *Boiler Enable* to the boiler's operating aquastat. While the 362's *Boiler* contact is made, the variable speed injection pump (P3) is also modulated to protect the boiler from excessively low water temperatures.

Mixing Demand (Mix 2) When heat is required in the Mix 2 zone, the 362 turns on the mixing system pump (P4) and the boiler pump (P1). The mixed supply water temperature is based on the *Characterized Heating Curve* settings as well as the indoor temperature feedback that is being received from the Indoor Sensor. The variable speed injection pump (P5) is then controlled to supply the required mixed supply water temperature. As the variable speed injection pump ramps up, the 362 uses its *Boiler* contact (terminals 6 and 7) to send a *Boiler Enable* to the boiler's operating aquastat. While the 362's *Boiler* contact is made, the variable speed injection pump (P5) is also modulated to protect the boiler from excessively low water temperatures.

All control functions and specifications are listed in the Product Catalog I 000 and Data Brochure D 362.

Required Material and Essential Control Settings

Required tekmar Products

2 x Universal Reset Control 362
 Indoor Sensor 076 or 077
 1 x tekmar Relay 004

Optional tekmar Products

Remote Display Module (RDM) 040
 Timer 031

362 Essential Application Control Settings (Adjust Menu)

<u>Item Field</u>	<u>Setting</u>
Control 1 & 2	
MODE	-1-
MIXING	VAR
Boil SENS	RET
Control 2	
10K	INDR

Note For all other settings, refer to the Data Brochure D 362.



tekmar Control Systems Ltd., Canada
 tekmar Control Systems, Inc., U.S.A.
Head Office: 5100 Silver Star Road
Vernon, B.C. Canada V1B 3K4
Tel. (250) 545-7749 Fax. (250) 545-0650
Web Site: www.tekmarcontrols.com

tekmar® - Application

Mixing Control 362 & Boiler Control 262

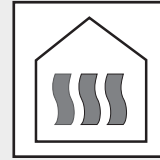
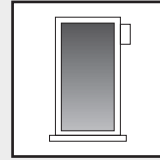

A 362-4

07/99

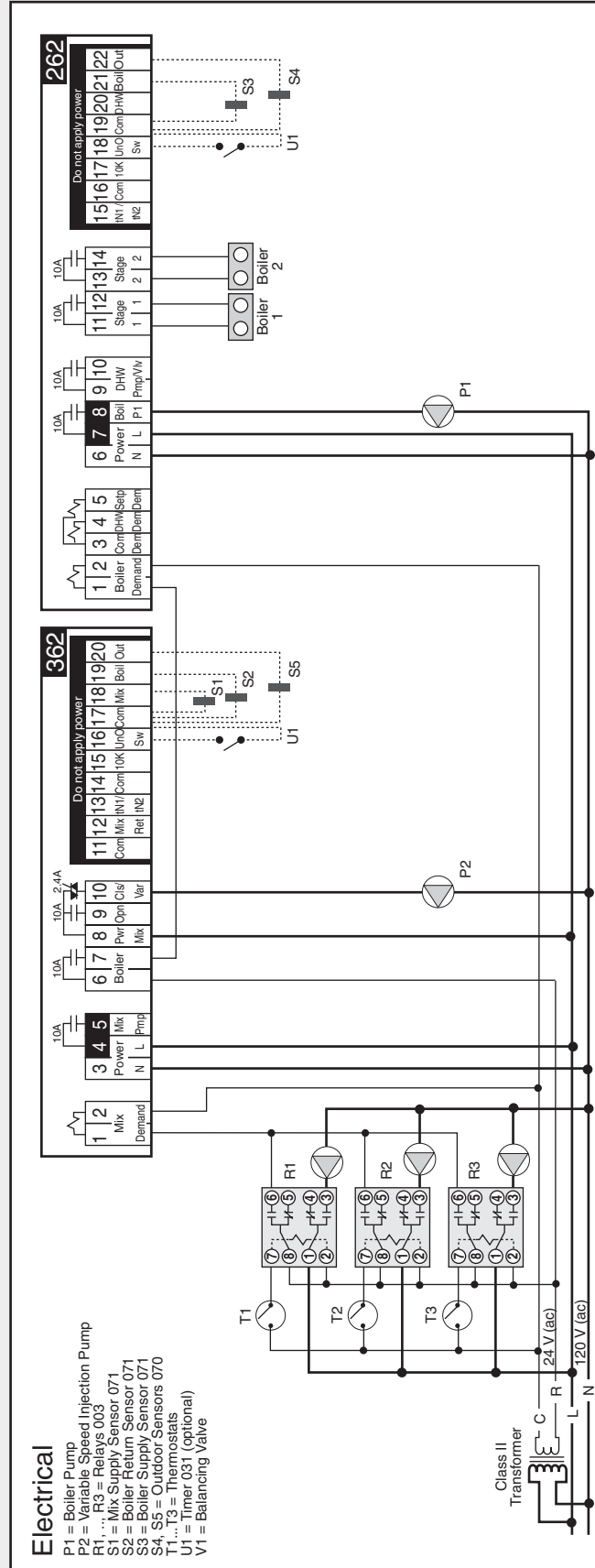
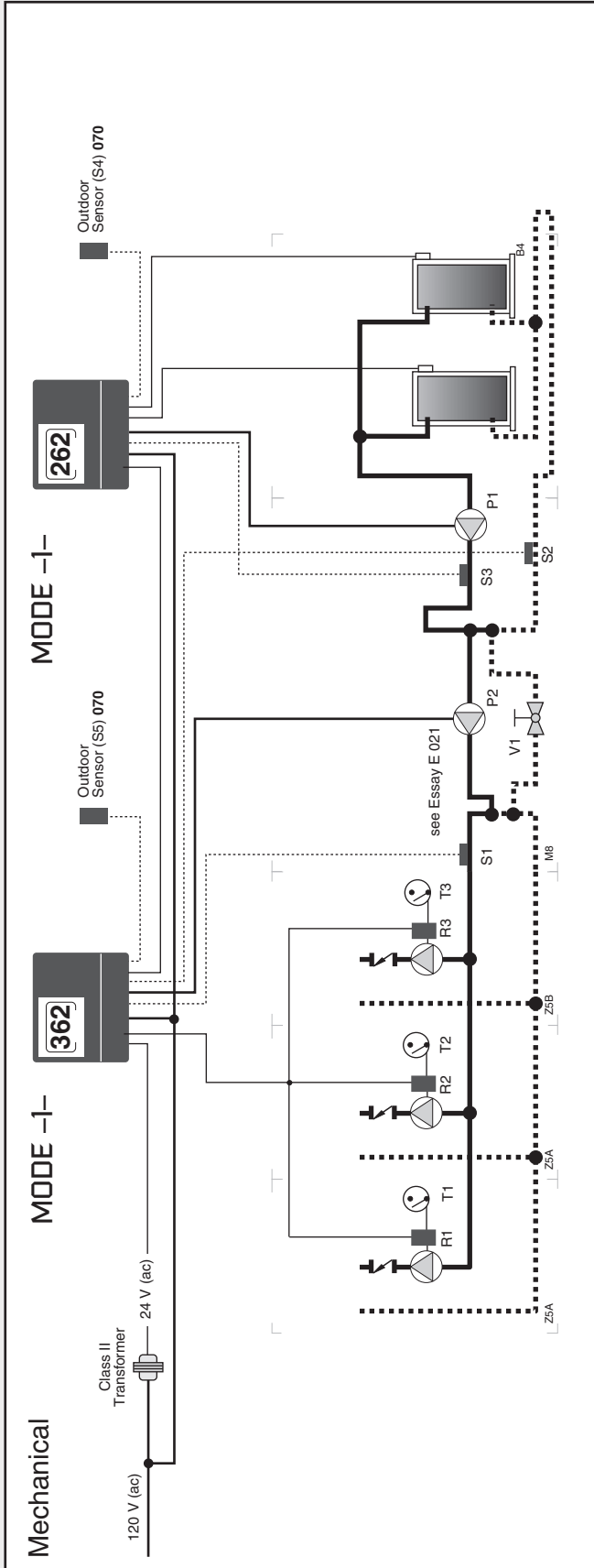

Note: This is only a concept drawing. The designer must determine whether this application will work in his system and must ensure compliance with code requirements. Necessary auxiliary equipment, isolation relays (for loads greater than the specified tekmar internal relay ratings), and other safety and limit devices must be added.

System Operation

The Mixing Control 362 and the Boiler Control 262 are combined to provide full outdoor reset to three (or more) mixed zones. The 362 controls the output of the variable speed injection pump to provide a mixed supply water temperature to the mixed zones and protect the boilers from flue gas condensation. The 262 stages the boilers based on the current loads on the system in order to provide the supply temperature that satisfies all loads.

Heat Source Details The heat sources can be either high mass or low mass non-condensing boilers.

Piping Details Thermostat controlled zone pumps are piped into the mixed loop. The variable speed injection pump is piped in primary / secondary in order to isolate the boiler loop flow rate from the mixed loop flow rates. The boilers are piped in reverse return in order to ensure equal flow through both boilers. The boiler pump (P1) provides flow through the boilers and ensures flow past the variable speed injection pump take-off.

Mixing Demand When heat is required in the mixed zones, the zone pump relays send a *Mix Demand* to the 362. The mixed supply water temperature is based on the *Reset Ratio or Characterized Heating Curve* settings. The variable speed injection pump (P2) is controlled to supply the required mixed supply water temperature. As the variable speed injection pump ramps up, the 362 uses its *Boiler* contact (terminals 6 and 7) to send a *Boiler Demand* to the 262. While the 362 is sending a *Boiler Demand* to the 262, the variable speed injection pump (P2) is also modulated to protect the boilers from excessively low water temperatures.

Boiler Demand When the 262 receives a *Boiler Demand*, the 262 turns on the boiler pump (P1). The boiler supply water temperature is based on the *Reset Ratio or Characterized Heating Curve* settings. The boilers are staged to satisfy the required boiler supply water temperature. Whenever the boilers are fired, the 262 aims to increase the boiler supply temperature to at least the *Boil MIN* setting.

All control functions and specifications are listed in the Product Catalog I 000 and Data Brochure D 362.

Required Material and Essential Control Settings

Required tekmar Products

Mixing Control 362
Boiler Control 262
3 x tekmar Relay 003

362 Essential Application Control Settings (Adjust Menu)

Item Field	Setting
MODE	-1-
MIXING	VAR
Boil SENS	RET

Optional tekmar Products

Timer 031

262 Essential Application RTU Settings (Adjust Menu)

Item Field	Setting
MODE	-1-
DHW THRU	NONE

Note For all other settings, refer to the Data Brochure D 362 and D 262.



tekmar Control Systems Ltd., Canada
tekmar Control Systems, Inc., U.S.A.
Head Office: 5100 Silver Star Road
Vernon, B.C. Canada V1B 3K4
Tel. (250) 545-7749 Fax. (250) 545-0650
Web Site: www.tekmarcontrols.com



Mechanical

MODE -2-

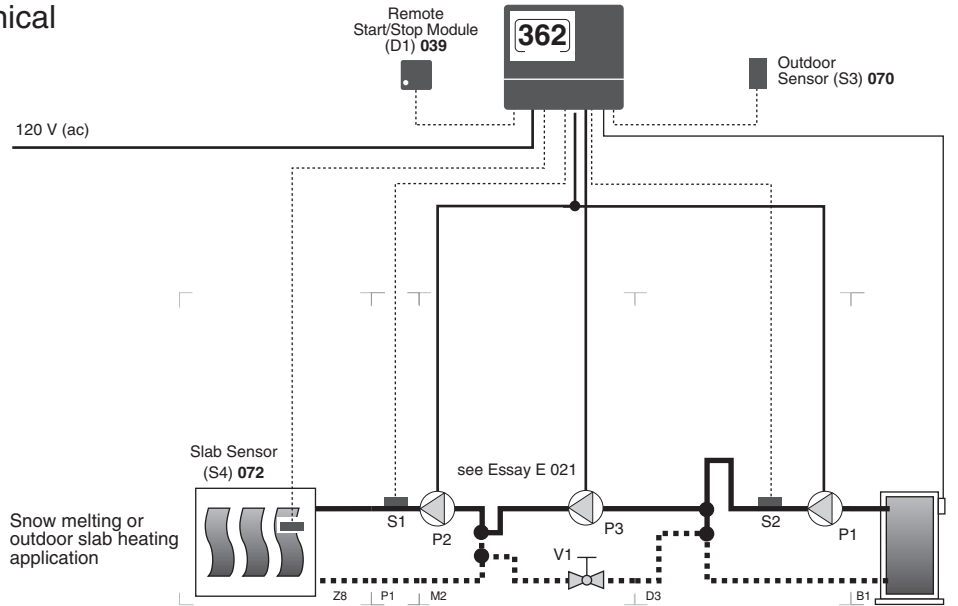

Electrical

- D1 = Remote Start/Stop Module 039
- P1 = Boiler Pump
- P2 = Mixing System Pump
- P3 = Variable Speed Injection Pump
- S1 = Mix Supply Sensor 071
- S2 = Boiler Supply Sensor 071
- S3 = Outdoor Sensor 070
- S4 = Slab Sensor 072
- V1 = Balancing Valve or Globe Valve

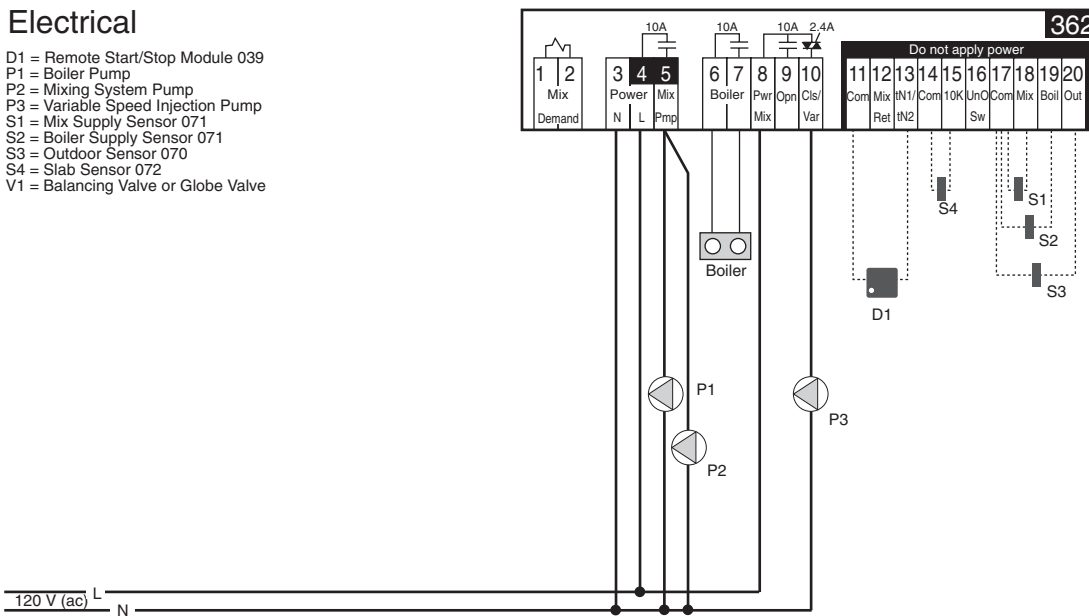

Note: This is only a concept drawing. The designer must determine whether this application will work in his system and must ensure compliance with code requirements. Necessary auxiliary equipment, isolation relays (for loads greater than the specified tekmar internal relay ratings), and other safety and limit devices must be added.

System Operation

The Mixing Control 362 provides a single zone snow melting system. The heat source is sized and dedicated to the snow melting system. The output of the variable speed injection pump is modulated to protect the boiler from flue gas condensation.

Heat Source Details The heat source can be either a high mass or low mass non-condensing or low temperature boiler.

Piping Details The snow melting slab is piped to allow for constant circulation through the slab. The variable speed injection pump is piped in primary / secondary in order to isolate the boiler loop flow rate from the mixed loop flow rate. The boiler pump (P1) provides flow through the boiler and ensures flow past the variable speed injection pump take-off.

Snow Melting Demand When snow melting is required, the button on the face of the Remote Start / Stop Module 039 is manually pressed. The 362 closes the *Mix Pmp* contact which then starts the boiler pump (P1) and the mixing system pump (P2). The mixed supply fluid temperature is determined by the control based on the outdoor air temperature, slab temperature, and melt or idle setting. The Control aims to maintain the slab temperature at the MELT setting. The 362 fires the boiler in order to supply heat to the snow melting system. While the boiler is firing, the variable speed injection pump (P3) is modulated to protect the boiler from excessively low supply fluid temperatures.

All control functions and specifications are listed in the Product Catalog I 000 and Data Brochure D 362.

Required Material and Essential Control Settings

Required tekmar Products

Universal Reset Control 362
Snow Melt Kit (SMK) 092

362 Essential Application Control Settings (Adjust Menu)

<u>Item Field</u>	<u>Setting</u>
MODE	-2-
MIXING	VAR
Boil SENS	SUP

Note For all other settings, refer to the Data Brochure D 362.



tekmar Control Systems Ltd., Canada
tekmar Control Systems, Inc., U.S.A.
Head Office: 5100 Silver Star Road
Vernon, B.C. Canada V1B 3K4
Tel. (250) 545-7749 Fax. (250) 545-0650
Web Site: www.tekmarcontrols.com



Mechanical

MODE -2-

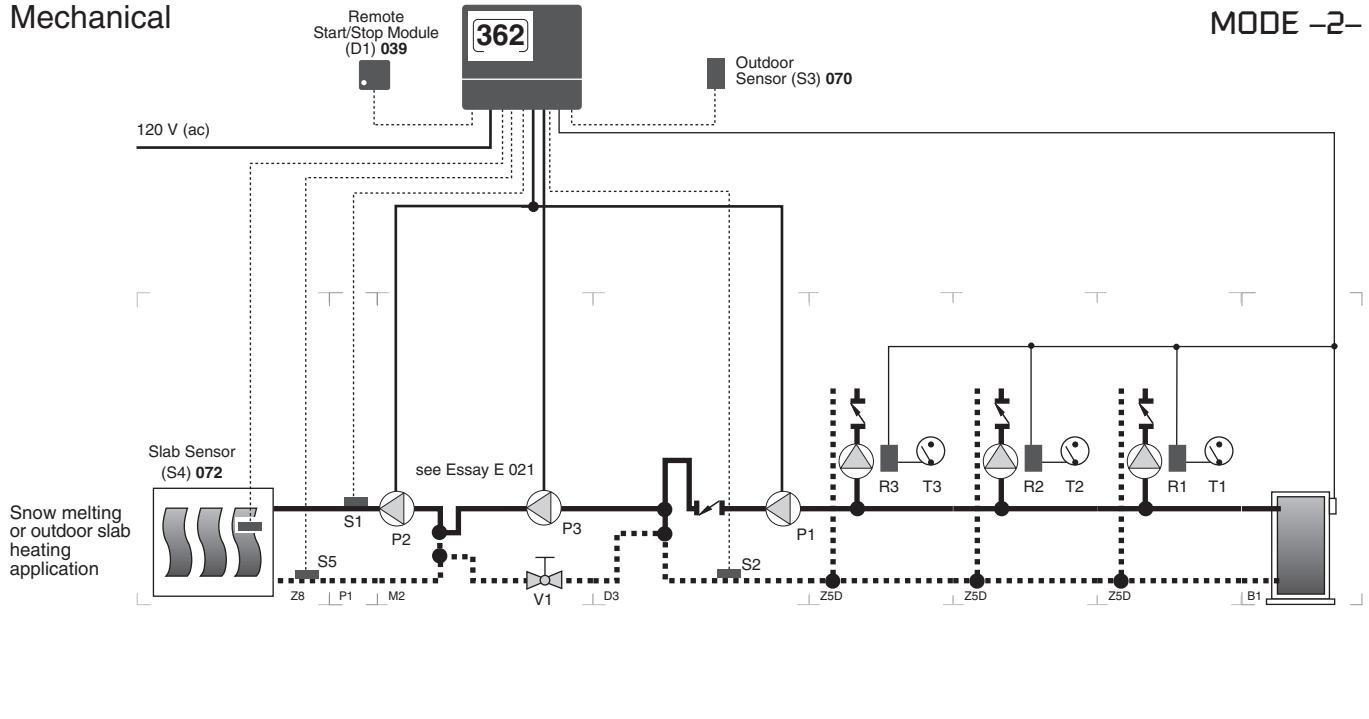

Electrical

- D1 = Remote Start / Stop Module 039
- P1 = Boiler Pump
- P2 = Mixing System Pump
- P3 = Variable Speed Injection Pump
- S1 = Mix Supply Sensor 071
- S2 = Boiler Return Sensor 071
- S3 = Outdoor Sensor 070
- S4 = Slab Sensor 072 or 073
- S5 = Mixing Return Sensor 071
- R1, ... R3 = Relays 003
- T1, ... T3 = Thermostats
- V1 = Balancing Valve or Globe Valve

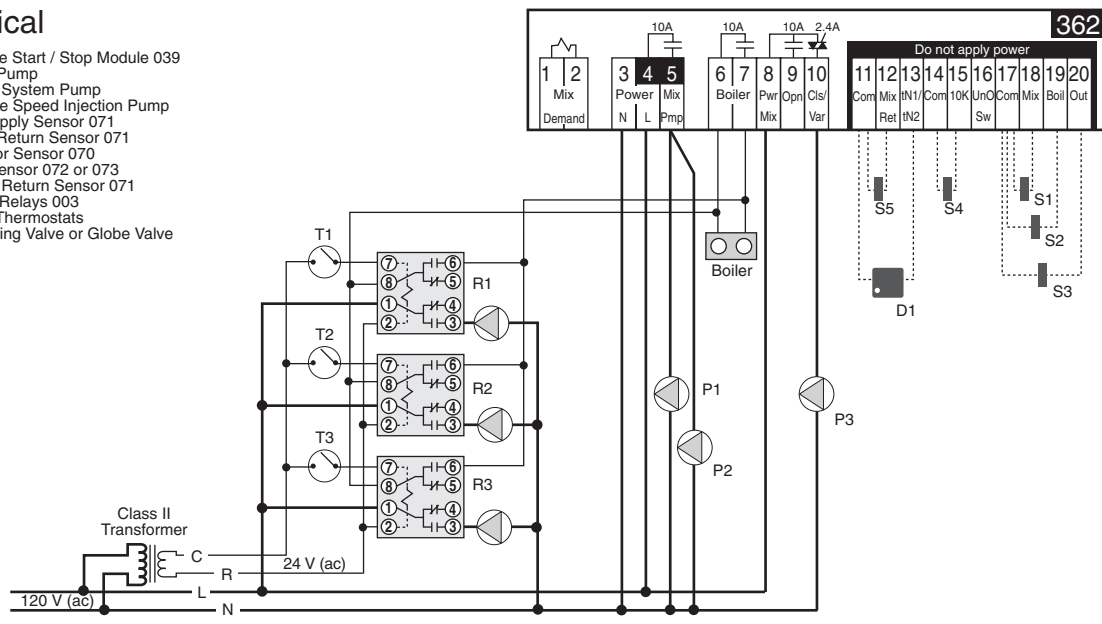

Note: This is only a concept drawing. The designer must determine whether this application will work in his system and must ensure compliance with code requirements. Necessary auxiliary equipment, isolation relays (for loads greater than the specified tekmar internal relay ratings), and other safety and limit devices must be added.

System Operation

The Mixing Control 362 provides a single zone snow melting system. The output of the variable speed injection pump is modulated to mix down the boiler supply fluid temperature to protect the slab from thermal stress and to protect the boiler from flue gas condensation.

Heat Source Details The heat source can be either a high mass or low mass non-condensing or low temperature boiler.

Piping Details The snow melting slab is piped to allow for constant circulation through the slab. The variable speed injection pump (P3) is piped in primary / secondary in order to isolate the boiler loop flow rate from the mixed loop flow rate. The boiler pump (P1) provides flow through the boiler and ensures flow past the variable speed injection pump take-off. Thermostat controlled zone pumps are piped into the boiler loop.

Snow Melting Demand When snow melting is required, the button on the face of the Remote Start / Stop Module 039 is manually pressed. The 362 closes the *Mix Pmp* contact which then starts the boiler pump (P1) and the mixing system pump (P2). The mixed supply fluid temperature is determined by the control based on the outdoor air temperature, slab temperature, and melt or idle setting. The control aims to maintain the slab temperature at the MELT setting. The variable speed injection pump (P3) is then controlled to supply the required mixed supply fluid temperature. As the variable speed injection pump (P3) ramps up, the 362 uses its *Boiler* contact (terminals 6 and 7) to fire the boiler. While the 362 is firing the boiler, the variable speed injection pump (P3) is modulated to protect the boiler from excessively low return fluid temperatures. Whenever heat is being supplied to the snow melting slab, the variable speed injection pump is also modulated to ensure that the ΔT across the slab does not exceed the ΔT MAX setting.

All control functions and specifications are listed in the Product Catalog I 000 and Data Brochure D 362.

Required Material and Essential Control Settings

Required tekmar Products

Universal Reset Control 362
Snow Melt Kit (SMK) 092

362 Essential Application Control Settings (Adjust Menu)

<u>Item Field</u>	<u>Setting</u>
MODE	-2-
MIXING	VAR
Boil SENS	RET

Note For all other settings, refer to the Data Brochure D 362.



tekmar Control Systems Ltd., Canada
tekmar Control Systems, Inc., U.S.A.
Head Office: 5100 Silver Star Road
Vernon, B.C. Canada V1B 3K4
Tel. (250) 545-7749 Fax. (250) 545-0650
Web Site: www.tekmarcontrols.com