

Mechanical

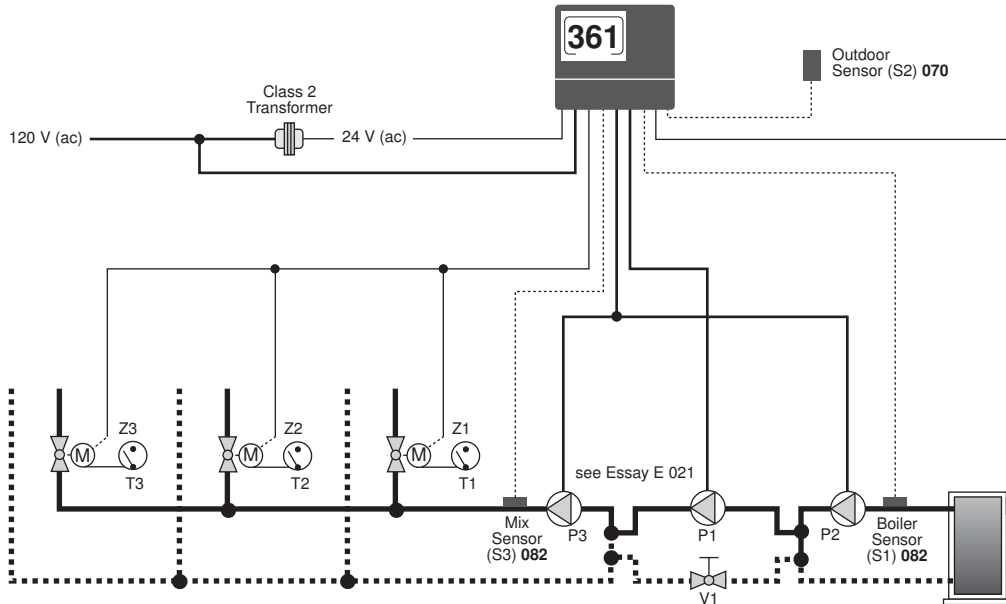

Electrical

- P1 = Variable Speed Injection Pump
- P2 = Boiler Pump
- P3 = Mixing System Pump
- S1 = Boiler Supply Sensor 082
- S2 = Outdoor Sensor 070
- S3 = Mix Supply Sensor 082
- T1, ..., T3 = Thermostats
- U1 = tekmar Timer 031 (optional)
- V1 = Balancing or Globe Valve
- Z1, ..., Z3 = Zone Valve Motor End Switches

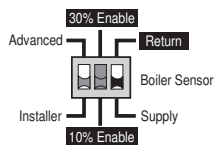

- = Required
- = Optional
- = Not Used

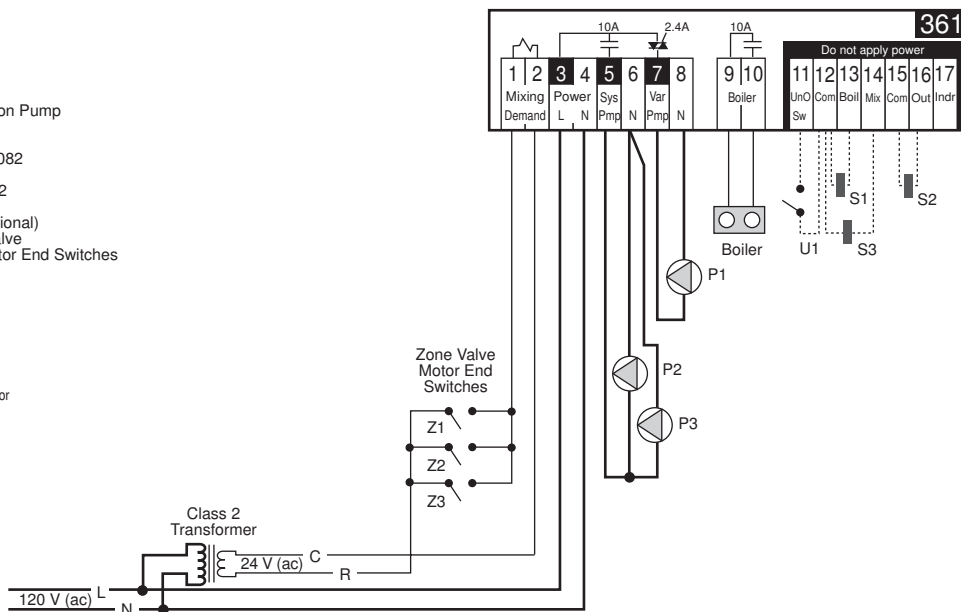

Note: This is only a concept drawing. The designer must determine whether this application will work in his system and must ensure compliance with code requirements. Necessary auxiliary equipment, isolation relays (for loads greater than the specified tekmar internal relay ratings), and other safety and limit devices must be added.

System Operation

The Mixing Control 361 provides full outdoor reset to three (or more) mixed zones. The output of the variable speed injection pump is modulated to mix the water temperature to the zones, and protect the boiler from flue gas condensation. The boiler operates at the required temperature in order to satisfy the load.

Heat Source Details The heat source can be either a high mass or low mass non-condensing boiler.

Piping Details Thermostat controlled zone valves are piped into the mixed loop. The variable speed injection pump (P1) is piped in primary / secondary in order to isolate the boiler loop flow rate from the mixed loop flow rate. The boiler pump (P2) provides flow through the boiler and ensures flow past the variable speed injection pump take-off.

Mixing Demand When heat is required in the mixed zones, the zone valve end switches send a *Mixing Demand* to the 361. The mixed supply water temperature is based on the *Characterized Heating Curve* settings. The variable speed injection pump (P1) is then controlled to supply the required mixed supply water temperature. As the variable speed injection pump ramps up and requires more heat from the boiler, the boiler is fired to a temperature that is sufficient to satisfy the requirements of the variable speed injection pump. Whenever the boiler is fired, the 361 aims to maintain the boiler temperature above the BOIL MIN setting. While the boiler is firing, the variable speed injection pump is also modulated to protect the boiler from excessively low water temperatures.

All control functions and specifications are listed in the Product Catalog I 000 and Data Brochure D 361.



tekmar Control Systems Ltd., Canada
 tekmar Control Systems, Inc., U.S.A.
Head Office: 5100 Silver Star Road
Vernon, B.C. Canada V1B 3K4
Tel. (250) 545-7749 Fax. (250) 545-0650
Web Site: www.tekmarcontrols.com



tekmar® - Application

Mixing Control 361

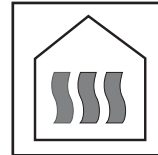

A 361-2

03/09

Mechanical

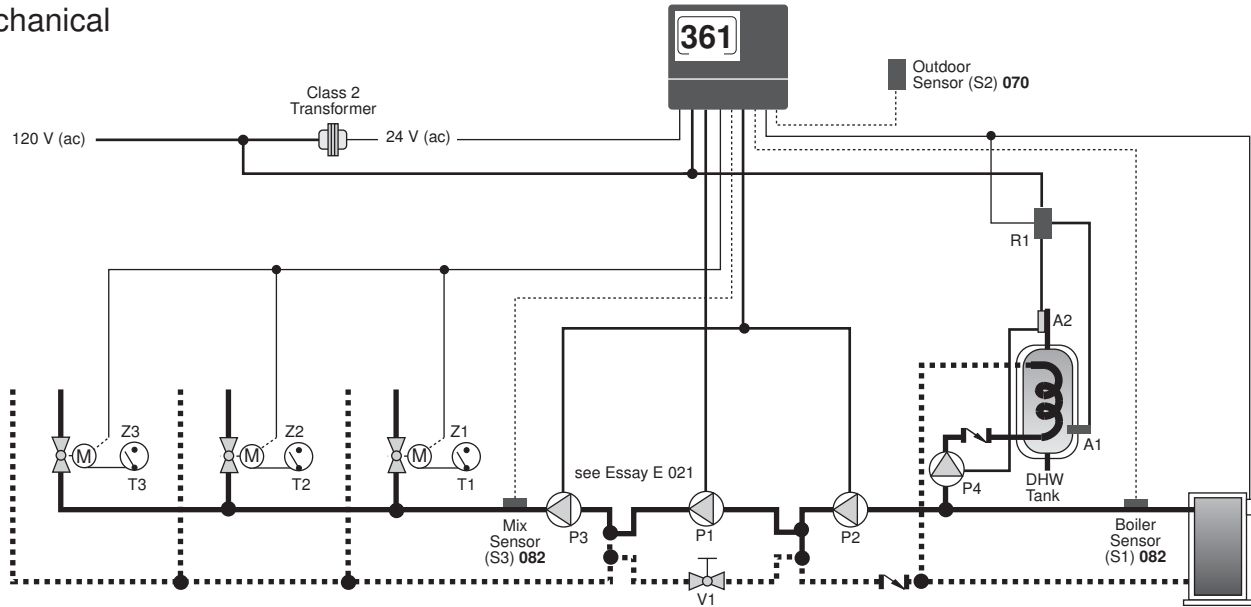

Electrical

- A1 = DHW Aquastat
- A2 = DHW High Limit Aquastat
- P1 = Variable Speed Injection Pump
- P2 = Boiler Pump
- P3 = Mixing System Pump
- P4 = DHW Pump
- R1 = Relay 004
- S1 = Boiler Supply Sensor 082
- S2 = Outdoor Sensor 070
- S3 = Mix Supply Sensor 082
- T1, ..., T3 = Thermostats
- U1 = tekmar Timer 031 (optional)
- V1 = Balancing or Globe Valve
- Z1, ..., Z3 = Zone Valve Motor End Switches

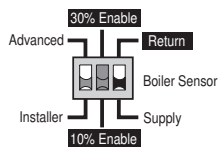

- = Required
- = Optional
- = Not Used

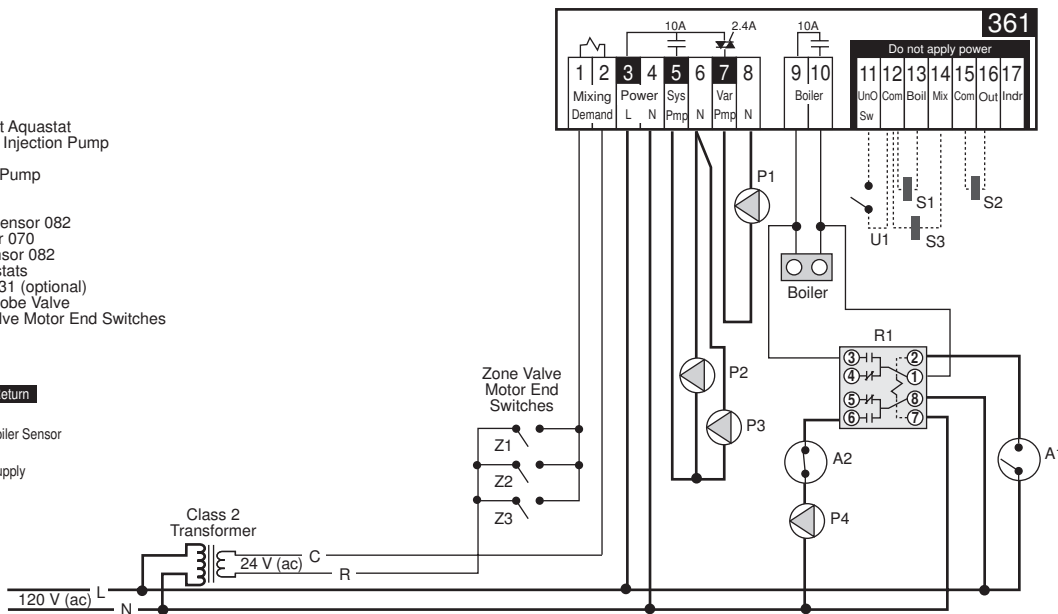

Note: This is only a concept drawing. The designer must determine whether this application will work in his system and must ensure compliance with code requirements. Necessary auxiliary equipment, isolation relays (for loads greater than the specified tekmar internal relay ratings), and other safety and limit devices must be added.

System Operation

The Mixing Control 361 provides full outdoor reset to three (or more) mixed zones. The output of the variable speed injection pump is modulated to mix the water temperature to the zones, and protect the boiler from flue gas condensation. The boiler operates at the required temperature in order to satisfy the loads. The supply of heat to an indirect Domestic Hot Water (DHW) tank is controlled through an external relay.

Heat Source Details The heat source can be either a high mass or low mass non-condensing boiler.

Piping Details Thermostat controlled zone valves are piped into the mixed loop. The variable speed injection pump (P1) is piped in primary / secondary in order to isolate the boiler loop flow rate from the mixed loop flow rate. Heat is supplied to the DHW tank through a DHW pump (P4). The boiler pump (P2) provides flow through the boiler and ensures flow past the variable speed injection pump take-off.

Domestic Hot Water (DHW) When the DHW tank requires heat, the DHW aquastat (A1) energizes relay R1. Relay R1 provides power to the DHW pump (P4) in order to provide circulation through the DHW tank. Once energized, relay R1 also enables the boiler. The boiler is then allowed to operate up to the operating aquastat's setting.

Mixing Demand When heat is required in the mixed zones, the zone valve end switches send a *Mixing Demand* to the 361. The mixed supply water temperature is based on the *Characterized Heating Curve* settings. The variable speed injection pump (P1) is then controlled to supply the required mixed supply water temperature. As the variable speed injection pump ramps up and requires more heat from the boiler, the boiler is fired to a temperature that is sufficient to satisfy the requirements of the variable speed injection pump. Whenever the boiler is fired, the 361 aims to maintain the boiler temperature above the BOIL MIN setting. While the boiler is firing, the variable speed injection pump is also modulated to protect the boiler from excessively low water temperatures.

All control functions and specifications are listed in the Product Catalog I 000 and Data Brochure D 361.



tekmar Control Systems Ltd., Canada
 tekmar Control Systems, Inc., U.S.A.
Head Office: 5100 Silver Star Road
Vernon, B.C. Canada V1B 3K4
Tel. (250) 545-7749 Fax. (250) 545-0650
Web Site: www.tekmarcontrols.com



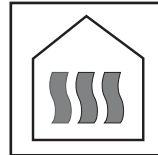

Mechanical

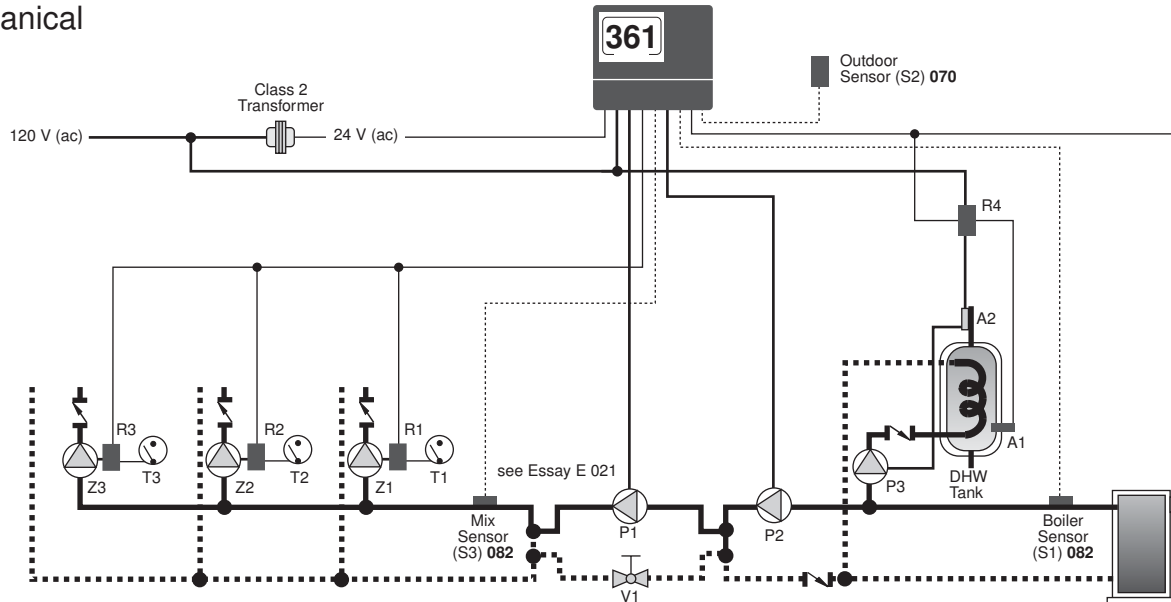

Electrical

- A1 = DHW Aquastat
- A2 = DHW High Limit Aquastat
- P1 = Variable Speed Injection Pump
- P2 = Boiler Pump
- P3 = DHW Pump
- R1, ..., R4 = Relay 003
- S1 = Boiler Supply Sensor 082
- S2 = Outdoor Sensor 070
- S3 = Mix Supply Sensor 82
- T1, ..., T3 = Thermostats
- U1 = tekmar Timer 031 (optional)
- V1 = Balancing or Globe Valve
- Z1, ..., Z3 = Zone Pumps

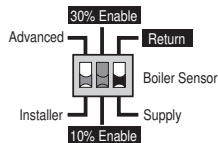

- = Required
- = Optional
- = Not Used

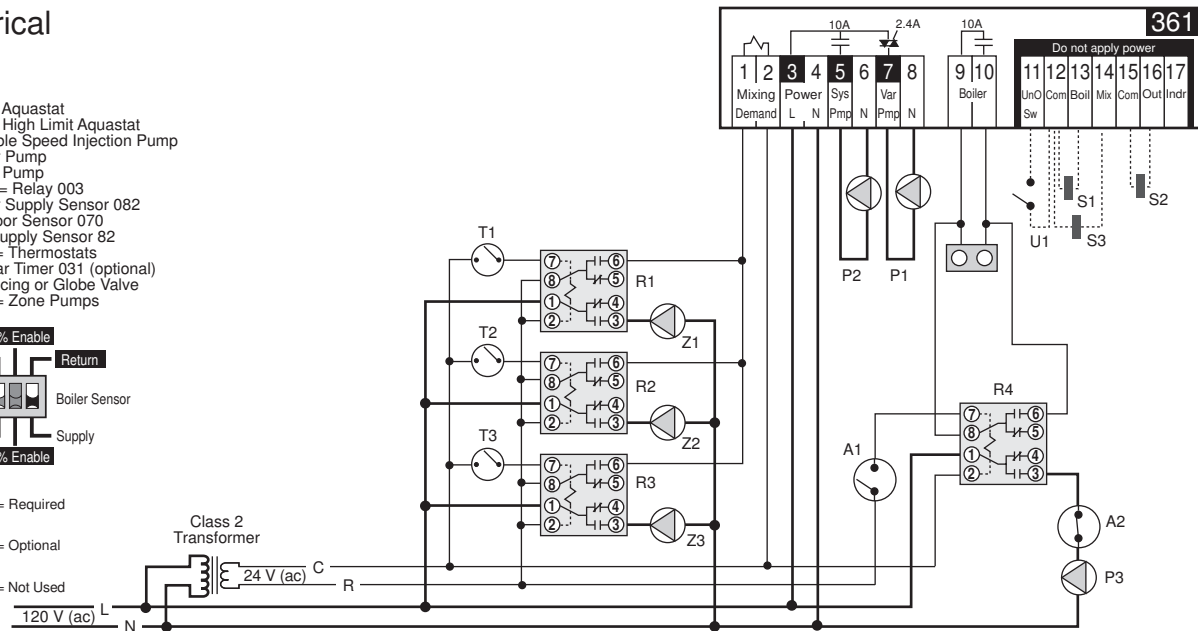

Note: This is only a concept drawing. The designer must determine whether this application will work in his system and must ensure compliance with code requirements. Necessary auxiliary equipment, isolation relays (for loads greater than the specified tekmar internal relay ratings), and other safety and limit devices must be added.

System Operation

The Mixing Control 361 provides full outdoor reset to three (or more) mixed zones. The output of the variable speed injection pump is modulated to mix the water temperature to the zones, and protect the boiler from flue gas condensation. The boiler operates at the required temperature in order to satisfy the loads. The supply of heat to an indirect Domestic Hot Water (DHW) tank is controlled through an external relay.

Heat Source Details The heat source can be either a high mass or low mass non-condensing boiler.

Piping Details Thermostat controlled zone pumps are piped into the mixed loop. The variable speed injection pump (P1) is piped in primary / secondary in order to isolate the boiler loop flow rate from the mixed loop flow rate. Heat is supplied to the DHW tank through a DHW pump (P3). The boiler pump (P2) provides flow through the boiler and ensures flow past the variable speed injection pump take-off.

Domestic Hot Water (DHW) When the DHW tank requires heat, the DHW aquastat (A1) energizes relay R4. Relay R4 provides power to the DHW pump (P3) in order to provide circulation through the DHW tank. Once energized, relay R4 also enables the boiler. The boiler is then allowed to operate up to the operating aquastat's setting.

Mixing Demand When heat is required in the mixed zones, the zone pump relays send a *Mixing Demand* to the 361. The mixed supply water temperature is based on the *Characterized Heating Curve* settings. The variable speed injection pump (P1) is then controlled to supply the required mixed supply water temperature. As the variable speed injection pump ramps up and requires more heat from the boiler, the boiler is fired to a temperature that is sufficient to satisfy the requirements of the variable speed injection pump. Whenever the boiler is fired, the 361 aims to maintain the boiler temperature above the BOIL MIN setting. While the boiler is firing, the variable speed injection pump is also modulated to protect the boiler from excessively low water temperatures.

All control functions and specifications are listed in the Product Catalog I 000 and Data Brochure D 361.



tekmar Control Systems Ltd., Canada
 tekmar Control Systems, Inc., U.S.A.
Head Office: 5100 Silver Star Road
Vernon, B.C. Canada V1B 3K4
Tel. (250) 545-7749 Fax. (250) 545-0650
Web Site: www.tekmarcontrols.com



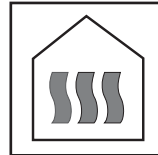

Mechanical

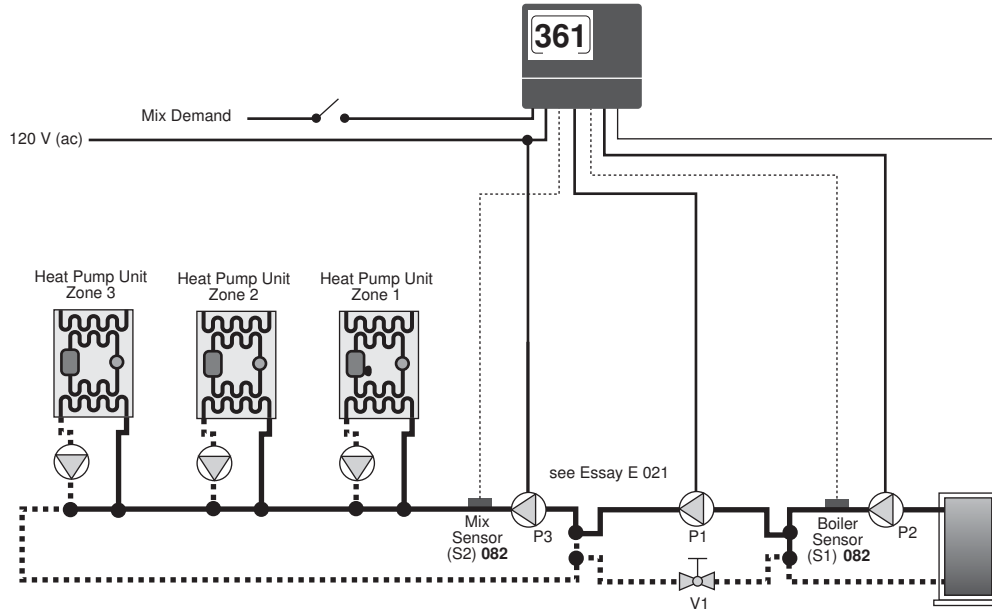

Electrical

- D1 = Mix Demand
- P1 = Variable Speed Injection Pump
- P2 = Boiler Pump
- P3 = Mixing System Pump
- S1 = Boiler Supply Sensor 082
- S2 = Mix Supply Sensor 082
- V1 = Balancing or Globe Valve

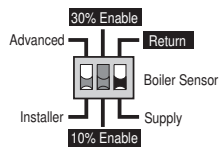

- = Required
- = Optional
- = Not Used

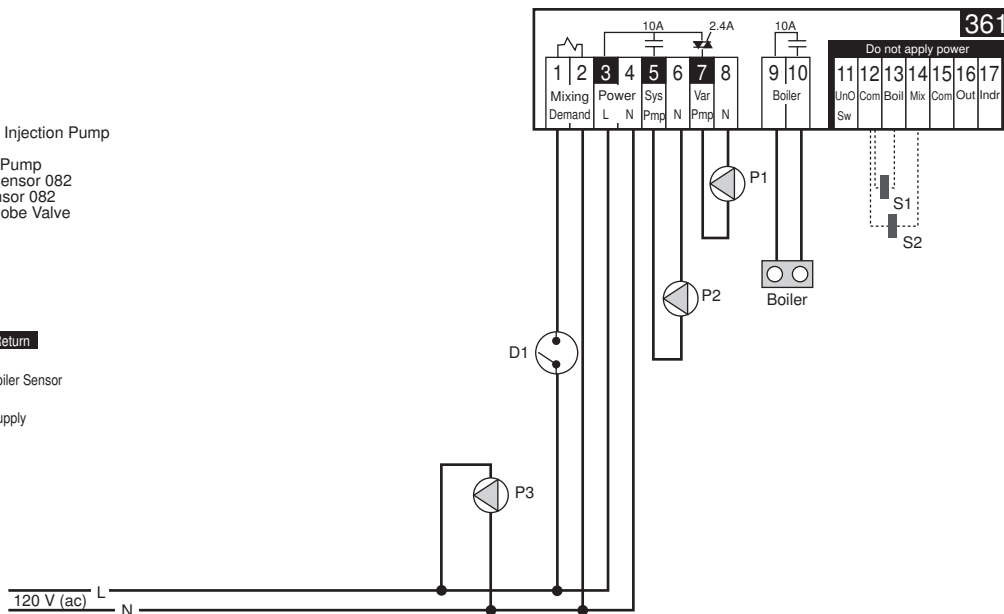

Note: This is only a concept drawing. The designer must determine whether this application will work in his system and must ensure compliance with code requirements. Necessary auxiliary equipment, isolation relays (for loads greater than the specified tekmar internal relay ratings), and other safety and limit devices must be added.

System Operation

The Mixing Control 361 provides setpoint control to a heat pump loop. The output of the variable speed injection pump is modulated to provide a fixed water temperature to the loop, and protect the boiler from flue gas condensation. The boiler operates at the required temperature in order to satisfy the load.

Heat Source Details The heat source can be either a high mass or low mass non-condensing boiler.

Piping Details Heat pump units are piped into the mixed loop. The variable speed injection pump (P1) is piped in primary / secondary in order to isolate the boiler loop flow rate from the mixed loop flow rate. The boiler pump (P2) provides flow through the boiler and ensures flow past the variable speed injection pump take-off.

Mixing Demand When heat is required in the heat pump loop, the switch provides a *Mixing Demand* to the 361. The mixed supply water temperature is fixed based on the MIX TARGET setpoint. The variable speed injection pump (P1) is then controlled to supply the required mixed supply water temperature. As the variable speed injection pump ramps up and requires more heat from the boiler, the boiler is fired to a temperature that is sufficient to satisfy the requirements of the variable speed injection pump. Whenever the boiler is fired, the 361 aims to maintain the boiler temperature above the BOIL MIN setting. While the boiler is firing, the variable speed injection pump is also modulated to protect the boiler from excessively low water temperatures.

All control functions and specifications are listed in the Product Catalog I 000 and Data Brochure D 361.



tekmar Control Systems Ltd., Canada
 tekmar Control Systems, Inc., U.S.A.
Head Office: 5100 Silver Star Road
Vernon, B.C. Canada V1B 3K4
Tel. (250) 545-7749 Fax. (250) 545-0650
Web Site: www.tekmarcontrols.com



tekmar® - Application

Boiler Control 260 and Mixing Control 361

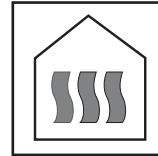

A 361-5

03/09

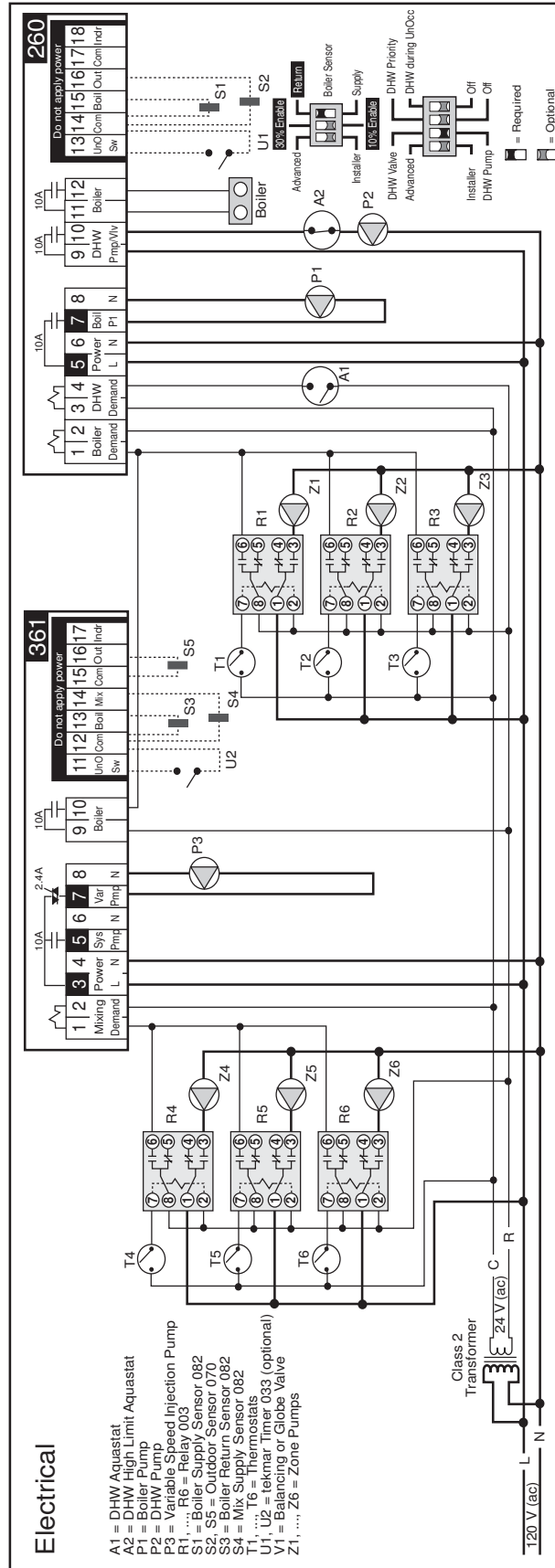
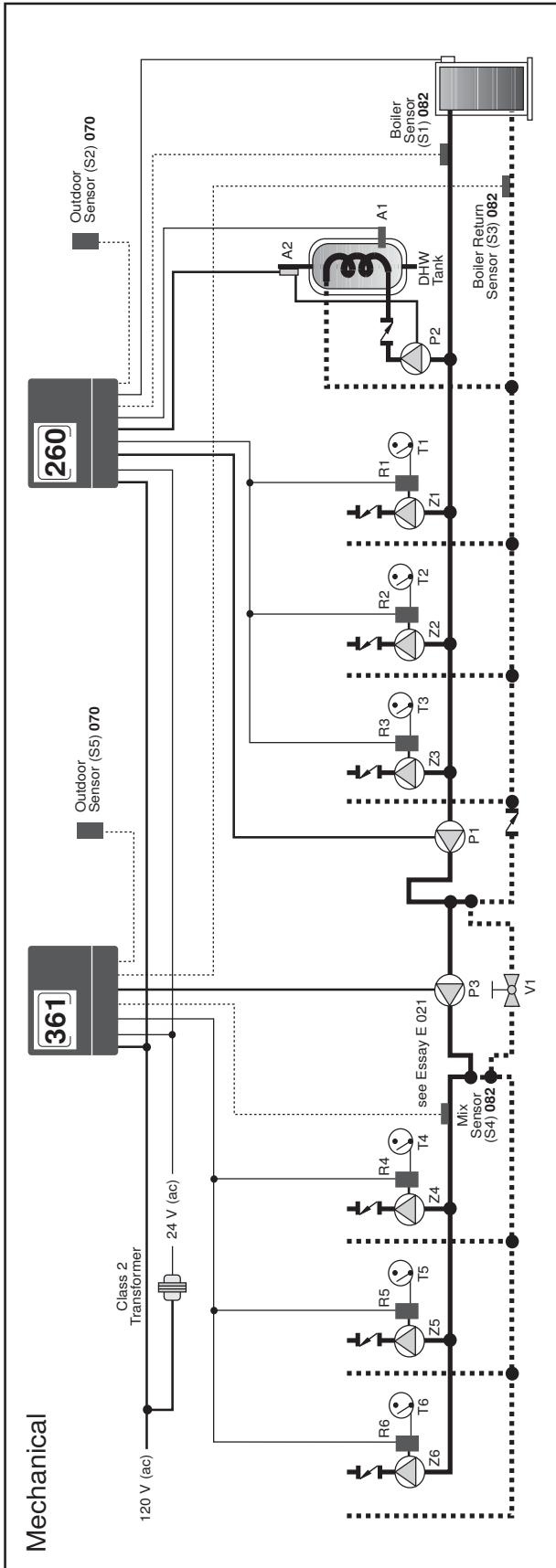

Note: This is only a concept drawing. The designer must determine whether this application will work in his system and must ensure compliance with code requirements. Necessary auxiliary equipment, isolation relays (for loads greater than the specified tekmar internal relay ratings), and other safety and limit devices must be added.

System Operation

The Mixing Control 361 and the Boiler Control 260 are combined to provide full outdoor reset to three (or more) mixed zones and partial outdoor reset to three (or more) boiler zones. The output of the variable speed injection pump is modulated to provide a mixed supply water temperature to the mixed zones, and protect the boiler from flue gas condensation. The boiler operates at the required temperature in order to satisfy all the loads. The 260 also controls the supply of heat to an indirect Domestic Hot Water (DHW) tank.

Heat Source Details The heat source can be either a high mass or low mass non-condensing boiler.

Piping Details Thermostat controlled zone pumps are piped into the mixed loop. The variable speed injection pump (P3) is piped in primary / secondary in order to isolate the boiler loop flow rate from the mixed loop flow rate. Thermostat controlled zone pumps are piped into the boiler loop. Heat is supplied to the DHW tank through a DHW pump (P2). The boiler pump (P1) provides flow through the boiler, and ensures flow past the variable speed injection pump take-off.

Domestic Hot Water (DHW) When the DHW aquastat (A1) calls for heat, the 260 turns on the DHW pump (P2) and raises the boiler water temperature to at least 180°F (82°C). The control can provide DHW priority by turning off the boiler pump (P1). Once the DHW demand is removed, the 260 performs a *DHW Post Purge* and possibly a *Mixing Purge*.

Mixing Demand When heat is required in the mixed zones, the zone pump relays send a *Mixing Demand* to the 361. The mixed supply water temperature is based on the *Characterized Heating Curve* settings. The variable speed injection pump (P3) is then controlled to supply the required mixed supply water temperature. As the variable speed injection pump ramps up, the 361 uses its *Boiler* contact (terminals 9 and 10) to send a *Boiler Demand* to the 260. While the 361 is sending a *Boiler Demand* to the 260, the variable speed injection pump (P3) is also modulated to protect the boiler from excessively low water temperatures.

Boiler Demand When heat is required in the boiler zones, the zone pump relays send a *Boiler Demand* to the 260. The 260 turns on the boiler pump (P1). The boiler supply water temperature is based on the *Characterized Heating Curve* settings. The boiler is staged to satisfy the required boiler supply water temperature. Whenever the boiler is fired, the 260 aims to increase the boiler supply water temperature to at least the BOIL MIN setting.

All control functions and specifications are listed in the Product Catalog I 000 and Data Brochures D 361 and D 260.



tekmar Control Systems Ltd., Canada
 tekmar Control Systems, Inc., U.S.A.
Head Office: 5100 Silver Star Road
Vernon, B.C. Canada V1B 3K4
Tel. (250) 545-7749 Fax. (250) 545-0650
Web Site: www.tekmarcontrols.com



tekmar® - Application

Boiler Control 261 & 2 x Mixing Control 361

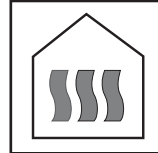

A 361-6

03/09

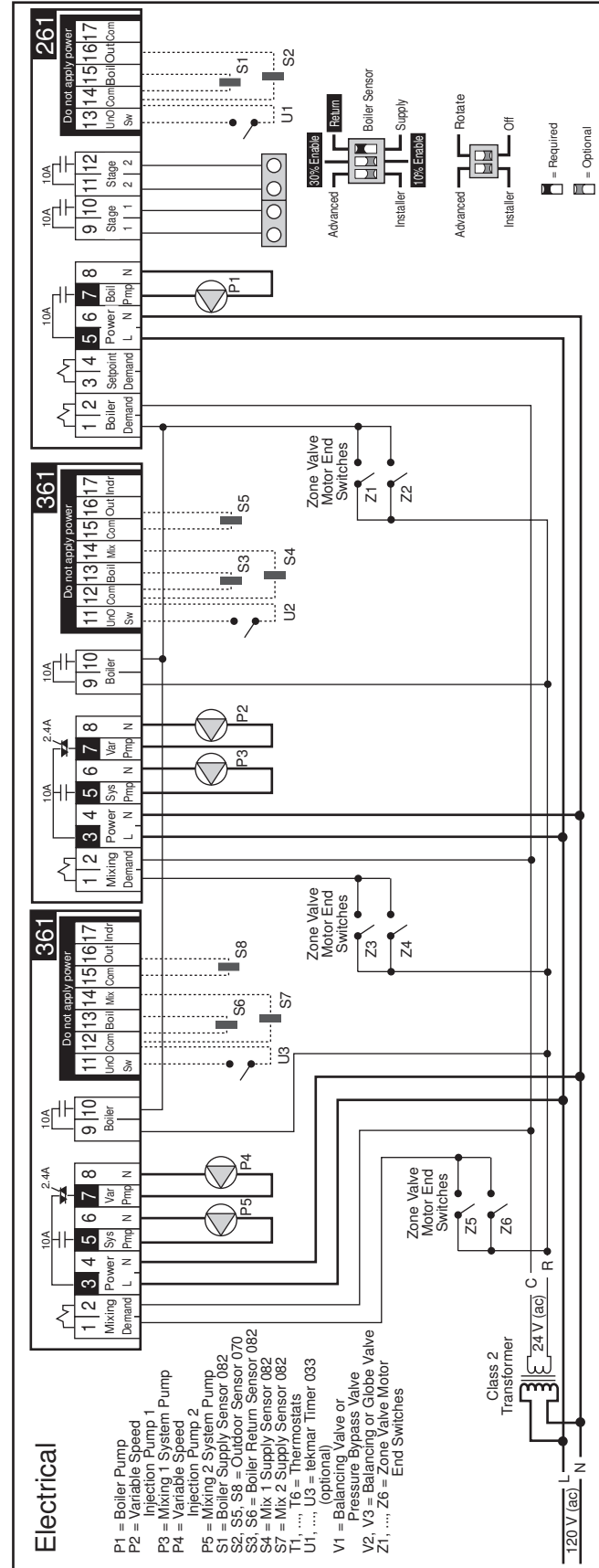
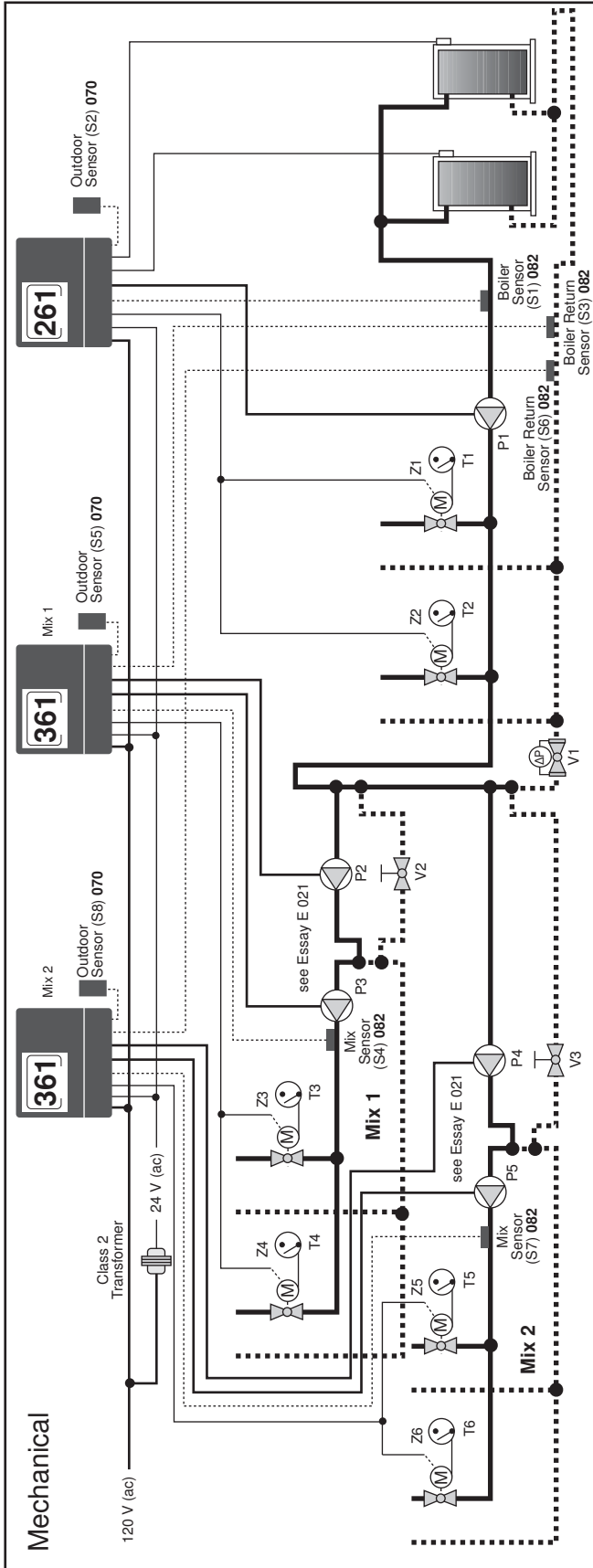

- P1 = Boiler Pump
- P2 = Variable Speed Injection Pump 1
- P3 = Mixing 1 System Pump
- P4 = Variable Speed Injection Pump 2
- P5 = Mixing 2 System Pump
- S1 = Boiler Supply Sensor 082
- S2, S5, S8 = Outdoor Sensor 070
- S3, S6 = Boiler Return Sensor 082
- S4 = Mix 1 Supply Sensor 082
- S7 = Mix 2 Supply Sensor 082
- T1, ..., T6 = Thermostats
- U1, ..., U3 = tekmar Timer 033 (optional)
- V1 = Balancing Valve or Pressure Bypass Valve
- V2, V3 = Balancing Globe Valve
- Z1, ..., Z6 = Zone Valve Motor End Switches

Note: This is only a concept drawing. The designer must determine whether this application will work in his system and must ensure compliance with code requirements. Necessary auxiliary equipment, isolation relays (for loads greater than the specified tekmar internal relay ratings), and other safety and limit devices must be added.

System Operation

Two Mixing Control 361's and the Boiler Control 261 are combined to provide full outdoor reset to two independent mixed temperature zones and partial outdoor reset to boiler zones. The output of the variable speed injection pump is modulated to provide a mixed supply water temperature to the mixed zones, and protect the boilers from flue gas condensation. The 261 stages the boilers based on the current loads in order to provide the required temperature that satisfies all the loads.

Heat Source Details The heat source can be either high mass or low mass non-condensing boilers.

Piping Details Thermostat controlled zone valves are piped into the mixed loops (Mix 1 and Mix 2). The variable speed injection pumps (P2 and P4) are piped in primary / secondary in order to isolate the boiler loop flow rate from the mixed loop flow rate. Thermostat controlled zone valves are piped into the boiler loop. The boiler pump (P1) provides flow through the boilers, and boiler zones, and ensures flow past the variable speed injection pump take-offs. A balancing valve (V1) creates a pressure differential so that flow will occur through the boiler zones when those zone valves are open.

Mixing Demand (Mix 1) When heat is required in the Mix 1 zones, the zone valve end switches send a *Mixing Demand* to the 361. The 361 turns on the mixing system pump (P3) and the boiler pump (P1). The mixed supply water temperature is based on the *Characterized Heating Curve* settings. The variable speed injection pump (P2) is then controlled to supply the required mixed supply water temperature. As the variable speed injection pump ramps up, the 361 uses its *Boiler* contact (terminals 9 and 10) to send a *Boiler Demand* to the 261. While the 361 is sending a *Boiler Demand* to the 261, the variable speed injection pump (P2) is also modulated to protect the boilers from excessively low water temperatures.

Mixing Demand (Mix 2) When heat is required in the Mix 2 zones, the zone valve end switches send a *Mixing Demand* to the 361. The 361 turns on the mixing system pump (P5) and the boiler pump (P1). The mixed supply water temperature is based on the *Characterized Heating Curve* settings. The variable speed injection pump (P4) is then controlled to supply the required mixed supply water temperature. As the variable speed injection pump ramps up, the 361 uses its *Boiler* contact (terminals 9 and 10) to send a *Boiler Demand* to the 261. While the 361 is sending a *Boiler Demand* to the 261, the variable speed injection pump (P4) is also modulated to protect the boilers from excessively low water temperatures.

Boiler Demand When heat is required in the boiler zones, the zone valve end switches send a *Boiler Demand* to the 261. The 261 turns on the boiler pump (P1). The boiler supply water temperature is based on the *Characterized Heating Curve* settings. The boilers are staged to satisfy the required boiler supply water temperature. Whenever the boilers are fired, the 261 aims to increase the boiler supply water temperature to at least the BOIL MIN setting.

All control functions and specifications are listed in the Product Catalog I 000 and Data Brochures D 361 and D 261.



tekmar Control Systems Ltd., Canada
 tekmar Control Systems, Inc., U.S.A.
Head Office: 5100 Silver Star Road
Vernon, B.C. Canada V1B 3K4
Tel. (250) 545-7749 Fax. (250) 545-0650
Web Site: www.tekmarcontrols.com

