

Mechanical

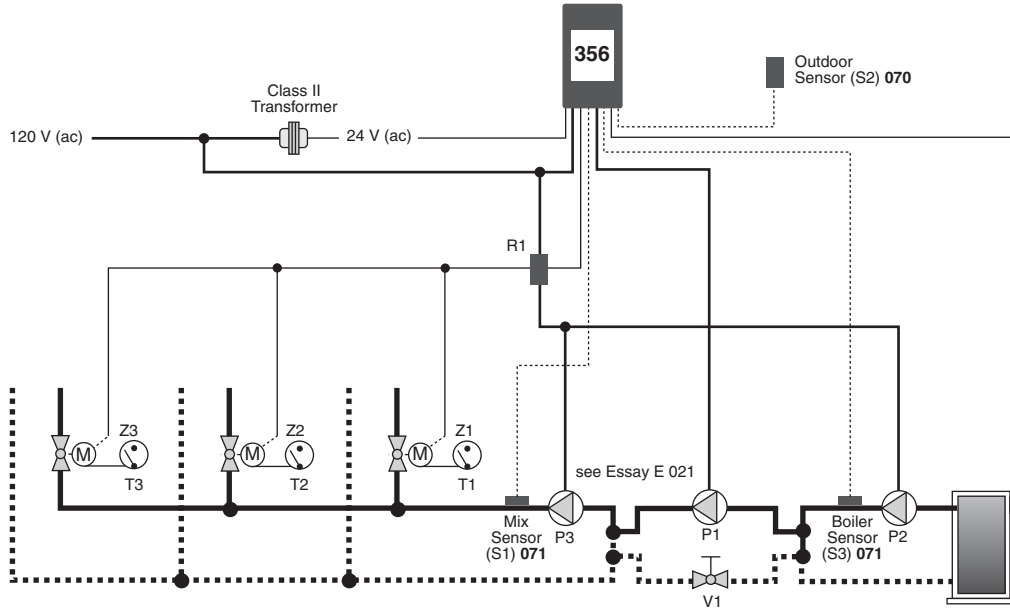

Electrical

- P1 = Variable Speed Injection Pump
- P2 = Boiler Pump
- P3 = Mixing System Pump
- R1 = Relay 003
- S1 = Mix Supply Sensor 071
- S2 = Outdoor Sensor 070
- S3 = Boiler Supply Sensor 071
- T1, ..., T3 = Thermostats
- V1 = Balancing or Globe Valve
- Z1, ..., Z3 = Zone Valve Motor End Switches

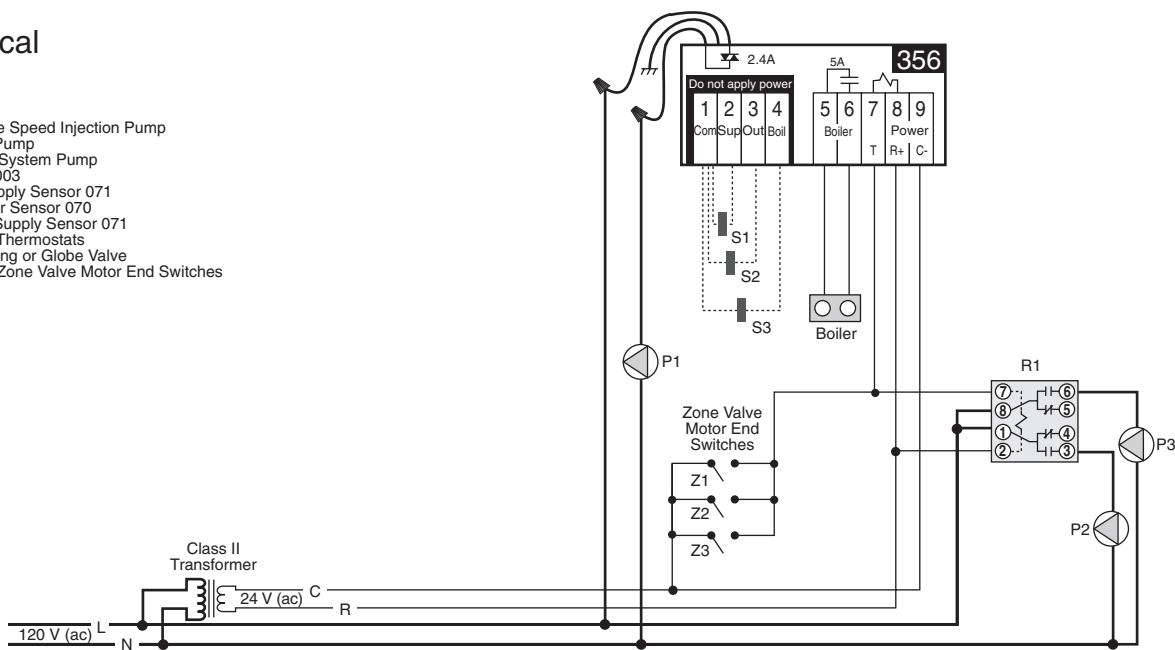

Note: This is only a concept drawing. The designer must determine whether this application will work in his system and must ensure compliance with code requirements. Necessary auxiliary equipment, isolation relays (for loads greater than the specified tekmar internal relay ratings), and other safety and limit devices must be added.

System Operation

The Mixing Control 356 provides full outdoor reset to three (or more) mixed zones. The output of the variable speed injection pump is modulated to mix the water temperature to the zones, and protect the boiler from flue gas condensation. The boiler operates at the required temperature in order to satisfy the load.

Heat Source Details The heat source can be either a high mass or low mass non-condensing boiler.

Piping Details Thermostat controlled zone valves are piped into the mixed loop. The variable speed injection pump (P1) is piped in primary / secondary in order to isolate the boiler loop flow rate from the mixed loop flow rate. The boiler pump (P2) provides flow through the boiler and ensures flow past the variable speed injection pump take-off.

Mixing Demand When heat is required in the mixed zones, the zone valve end switches provide a *Mixing Demand* to the 356 and turns on the boiler pump (P2) and mixing system pump (P3) through relay R1. The variable speed injection pump (P1) is then controlled to supply the required mixed supply water temperature. As the variable speed injection pump ramps up and requires more heat from the boiler, the boiler is fired to a temperature that is sufficient to satisfy the requirements of the variable speed injection pump. Whenever the boiler is fired, the 356 aims to maintain the boiler temperature above the BOIL MIN setting. While the boiler is firing, the variable speed injection pump is also modulated to protect the boiler from excessively low water temperatures.

All control functions and specifications are listed in the Product Catalog I 000 and Data Brochure D 356.



tekmar Control Systems Ltd., Canada
 tekmar Control Systems, Inc., U.S.A.
Head Office: 5100 Silver Star Road
Vernon, B.C. Canada V1B 3K4
Tel. (250) 545-7749 Fax. (250) 545-0650
Web Site: www.tekmarcontrols.com



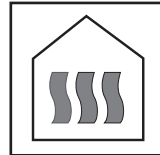

Mechanical

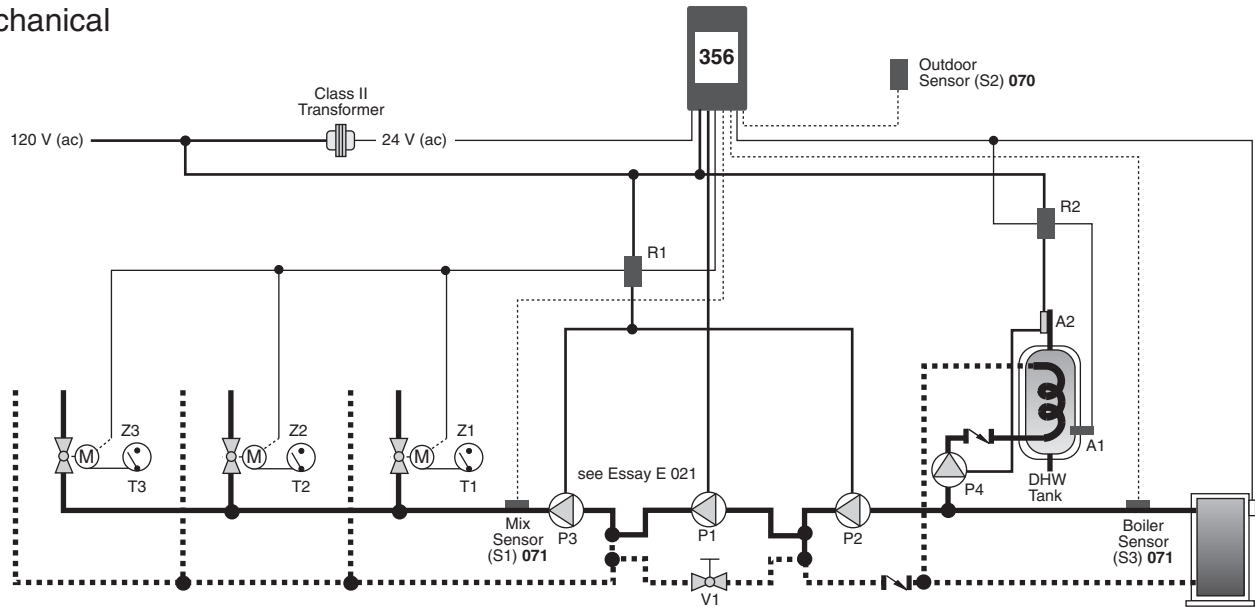

Electrical

- A1 = DHW Aquastat
- A2 = DHW High Limit Aquastat
- P1 = Variable Speed Injection Pump
- P2 = Boiler Pump
- P3 = Mixing System Pump
- P4 = DHW Pump
- R1, R2 = Relay 003
- S1 = Mix Supply Sensor 071
- S2 = Outdoor Sensor 070
- S3 = Boiler Supply Sensor 071
- T1, ..., T3 = Thermostats
- V1 = Balancing or Globe Valve
- Z1, ..., Z3 = Zone Valve Motor End Switches

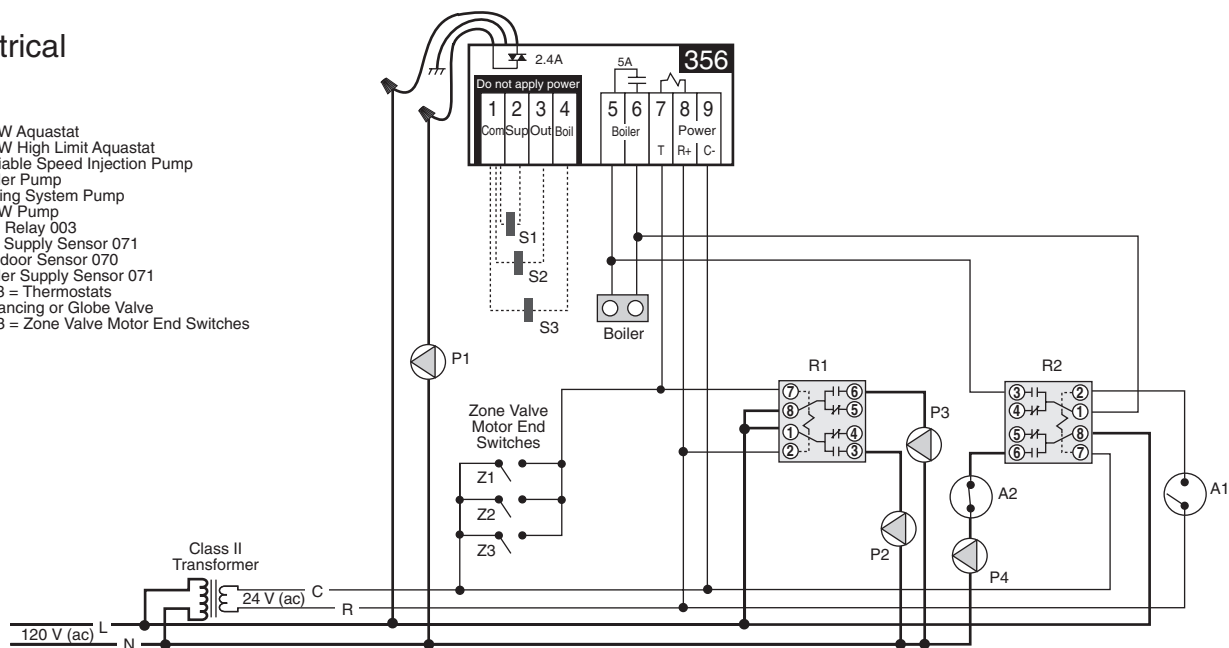

Note: This is only a concept drawing. The designer must determine whether this application will work in his system and must ensure compliance with code requirements. Necessary auxiliary equipment, isolation relays (for loads greater than the specified tekmar internal relay ratings), and other safety and limit devices must be added.

System Operation

The Mixing Control 356 provides full outdoor reset to three (or more) mixed zones. The output of the variable speed injection pump is modulated to mix the water temperature to the zones, and protect the boiler from flue gas condensation. The boiler operates at the required temperature in order to satisfy the loads. The supply of heat to an indirect Domestic Hot Water (DHW) tank is controlled through an external relay.

Heat Source Details The heat source can be either a high mass or low mass non-condensing boiler.

Piping Details Thermostat controlled zone valves are piped into the mixed loop. The variable speed injection pump (P1) is piped in primary / secondary in order to isolate the boiler loop flow rate from the mixed loop flow rate. Heat is supplied to the DHW tank through a DHW pump (P4). The boiler pump (P2) provides flow through the boiler and ensures flow past the variable speed injection pump take-off.

Domestic Hot Water (DHW) When the DHW tank requires heat, the DHW aquastat (A1) energizes relay R2. Relay R2 provides power to the DHW pump (P4) in order to provide circulation through the DHW tank. Once energized, relay R2 also enables the boiler. The boiler is then allowed to operate up to the operating aquastat's setting.

Mixing Demand When heat is required in the mixed zones, the zone valve end switches provide a *Mixing Demand* to the 356 and turns on the boiler pump (P2) and mixing system pump (P3) through relay R1. The variable speed injection pump (P1) is then controlled to supply the required mixed supply water temperature. As the variable speed injection pump ramps up and requires more heat from the boiler, the boiler is fired to a temperature that is sufficient to satisfy the requirements of the variable speed injection pump. Whenever the boiler is fired, the 356 aims to maintain the boiler temperature above the BOIL MIN setting. While the boiler is firing, the variable speed injection pump is also modulated to protect the boiler from excessively low water temperatures.

All control functions and specifications are listed in the Product Catalog I 000 and Data Brochure D 356.



tekmar Control Systems Ltd., Canada
 tekmar Control Systems, Inc., U.S.A.
Head Office: 5100 Silver Star Road
Vernon, B.C. Canada V1B 3K4
Tel. (250) 545-7749 Fax. (250) 545-0650
Web Site: www.tekmarcontrols.com



tekmar® - Application

Mixing Control 356



A 356-3

05/00

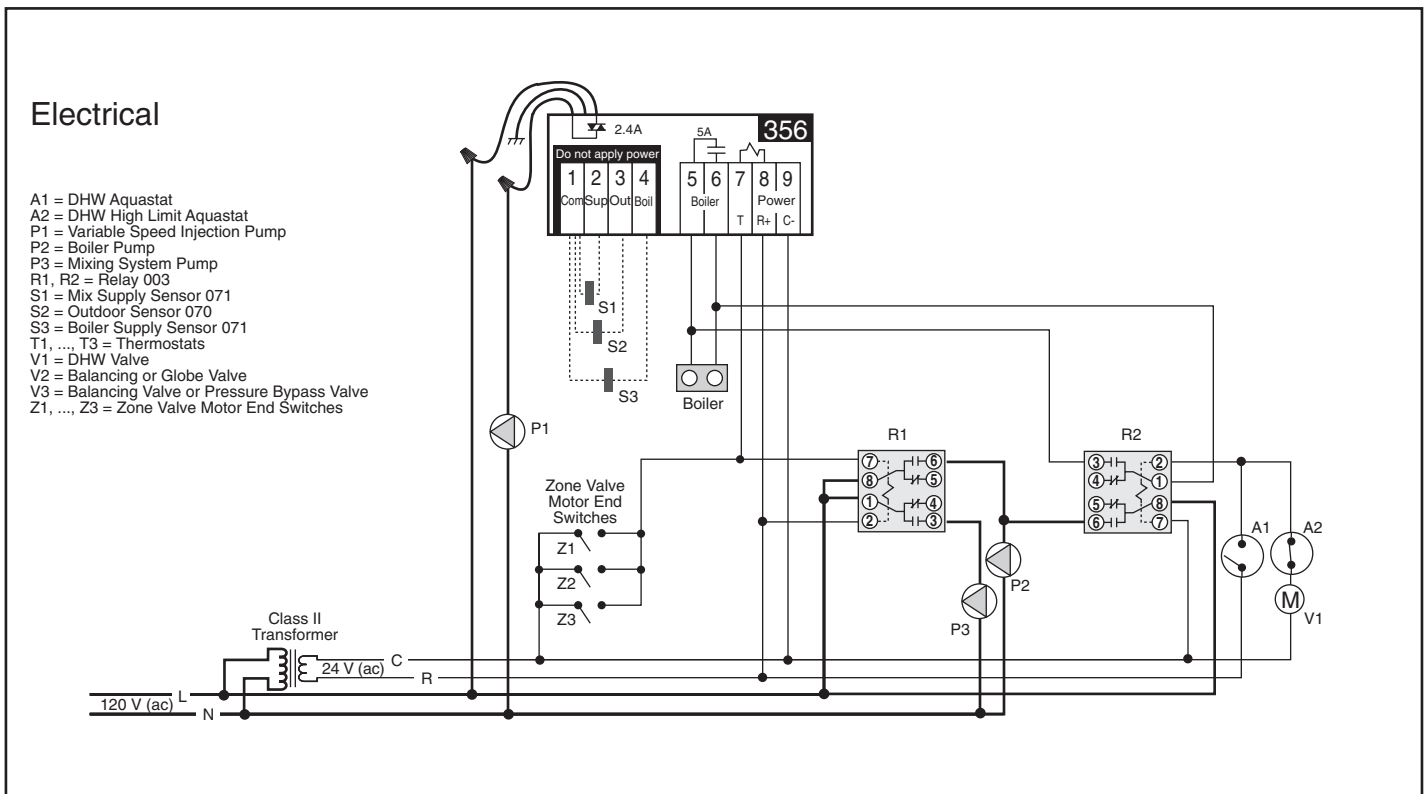
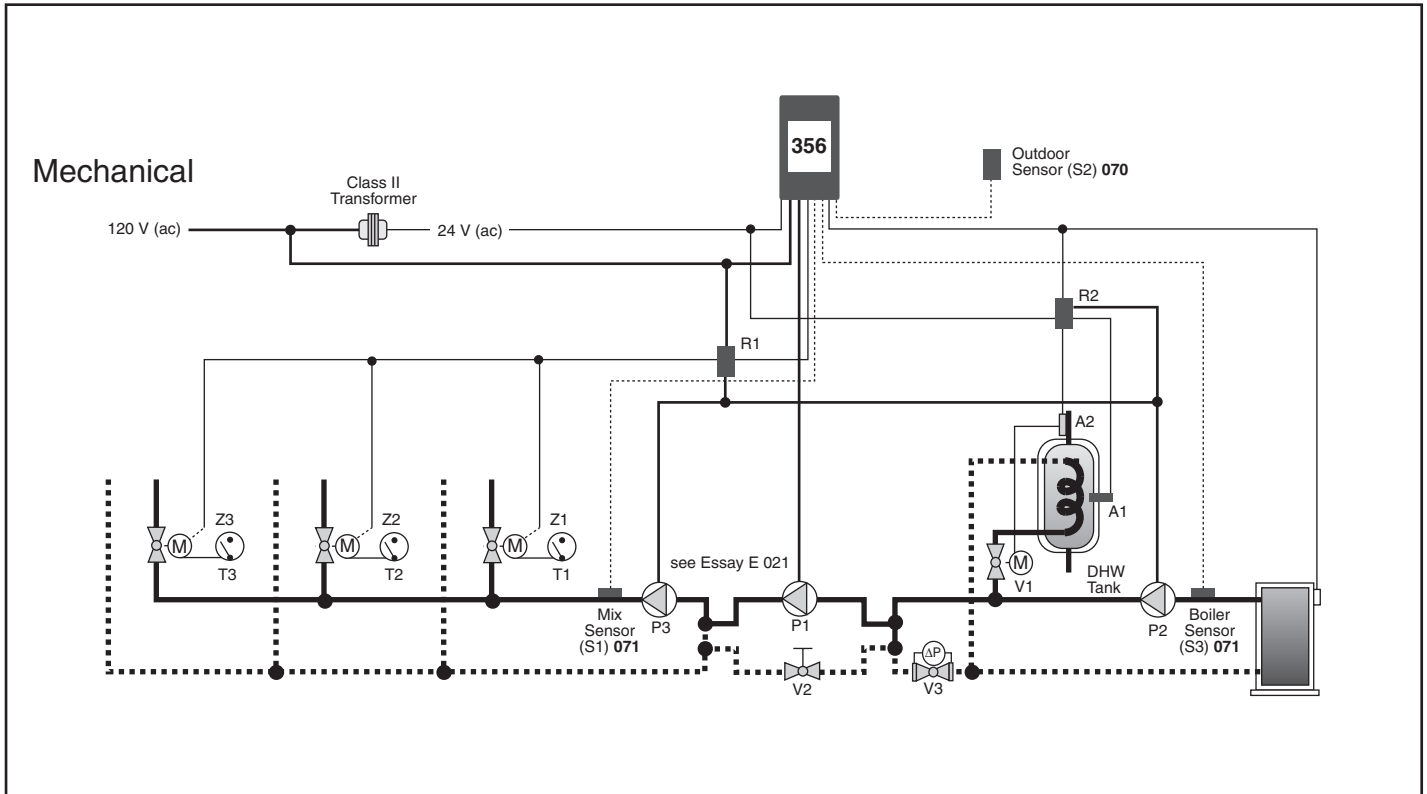

Note: This is only a concept drawing. The designer must determine whether this application will work in his system and must ensure compliance with code requirements. Necessary auxiliary equipment, isolation relays (for loads greater than the specified tekmar internal relay ratings), and other safety and limit devices must be added.

System Operation

The Mixing Control 356 provides full outdoor reset to three (or more) mixed zones. The output of the variable speed injection pump is modulated to mix the water temperature to the zones, and protect the boiler from flue gas condensation. The boiler operates at the required temperature in order to satisfy the loads. The supply of heat to an indirect Domestic Hot Water (DHW) tank is controlled through an external relay.

Heat Source Details The heat source can be either a high mass or low mass non-condensing boiler.

Piping Details Thermostat controlled zone valves are piped into the mixed loop. The variable speed injection pump (P1) is piped in primary / secondary in order to isolate the boiler loop flow rate from the mixed loop flow rate. Heat is supplied to the DHW tank through a DHW valve (V1). The boiler pump (P2) provides flow through the boiler and DHW valve, and ensures flow past the variable speed injection pump take-off.

Domestic Hot Water (DHW) When the DHW tank requires heat, the DHW aquastat (A1) energizes relay R2. Relay R2 provides power to the boiler pump (P2) and opens the DHW valve (V1) in order to provide circulation through the DHW tank. Once energized, relay R2 also enables the boiler. The boiler is then allowed to operate up to the operating aquastat's setting.

Mixing Demand When heat is required in the mixed zones, the zone valve end switches provide a *Mixing Demand* to the 356 and turns on the boiler pump (P2) and mixing system pump (P3) through relay R1. The variable speed injection pump (P1) is then controlled to supply the required mixed supply water temperature. As the variable speed injection pump ramps up and requires more heat from the boiler, the boiler is fired to a temperature that is sufficient to satisfy the requirements of the variable speed injection pump. Whenever the boiler is fired, the 356 aims to maintain the boiler temperature above the BOIL MIN setting. While the boiler is firing, the variable speed injection pump is also modulated to protect the boiler from excessively low water temperatures.

All control functions and specifications are listed in the Product Catalog I 000 and Data Brochure D 356.



tekmar Control Systems Ltd., Canada
 tekmar Control Systems, Inc., U.S.A.
Head Office: 5100 Silver Star Road
Vernon, B.C. Canada V1B 3K4
Tel. (250) 545-7749 Fax. (250) 545-0650
Web Site: www.tekmarcontrols.com



Mechanical

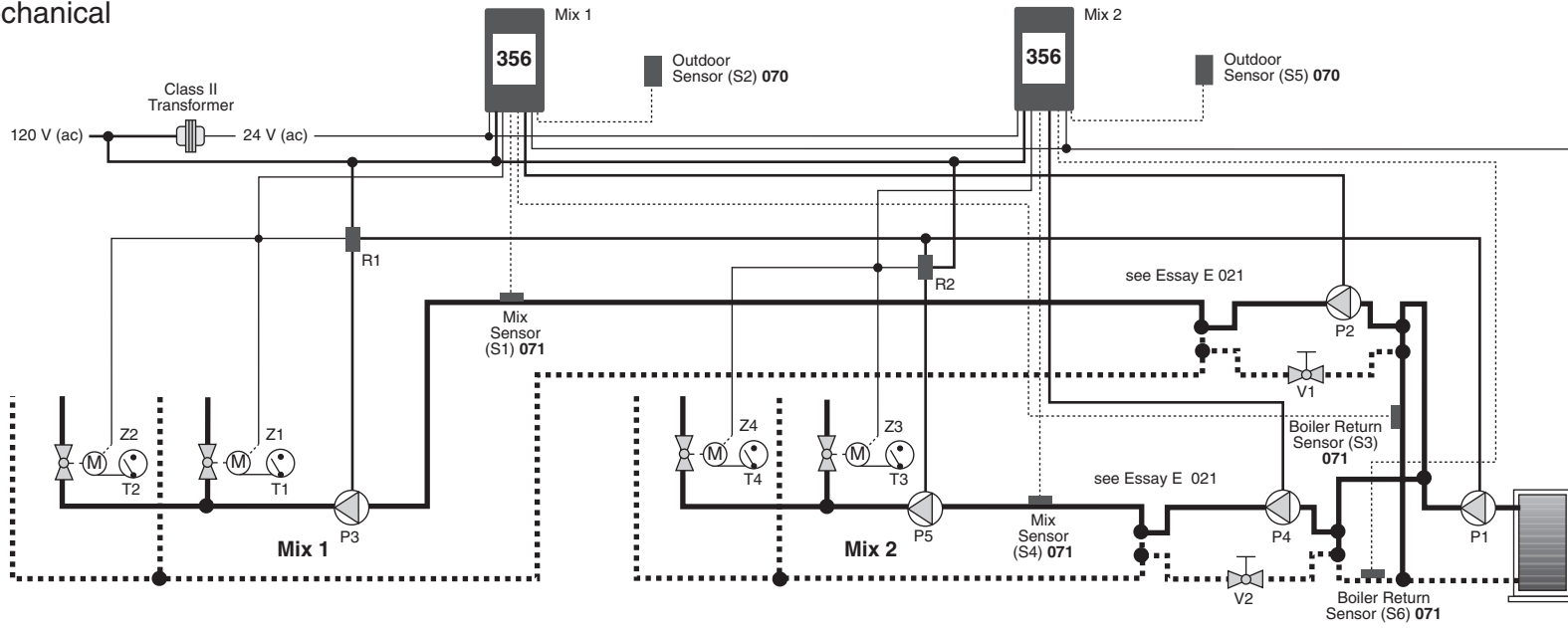

Electrical

- P1 = Boiler Pump
- P2, P4 = Variable Speed Injection Pump
- P3, P5 = Mixing System Pump
- R1, R2 = Relay 003
- S1, S4 = Mix Supply Sensor 071
- S2, S5 = Outdoor Sensor 070
- S3, S6 = Boiler Return Sensor 071
- T1, ..., T4 = Thermostats
- V1, V2 = Balancing Valve or Globe Valve
- Z1, ..., Z4 = Zone Valve Motor End Switches

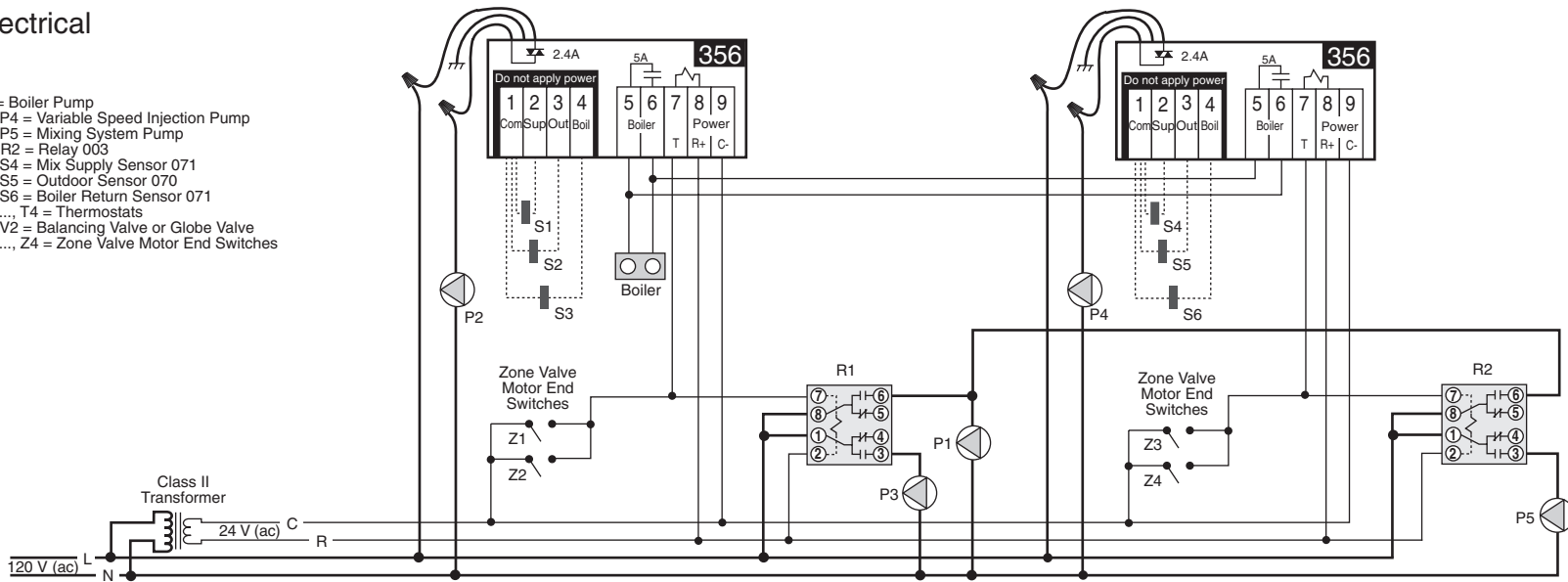

Note: This is only a concept drawing. The designer must determine whether this application will work in his system and must ensure compliance with code requirements. Necessary auxiliary equipment, isolation relays (for loads greater than the specified tekmar internal relay ratings), and other safety and limit devices must be added.



A 356-4
 05/00

System Operation

Two Mixing Control 356's provides full outdoor reset to two independent mixed temperatures. The outputs of the variable speed injection pumps are modulated to provide a mixed supply water temperature to the zones, and protect the boiler from flue gas condensation. The boiler operates at its operating aquastat temperature.

Heat Source Details The heat source can be either a high mass or low mass non-condensing boiler.

Piping Details Thermostat controlled zone valves are piped into the mixed loops (Mix 1 and Mix 2). The variable speed injection pumps (P2 and P4) are piped in primary / secondary in order to isolate the boiler loop flow rate from the mixed loop flow rate. The boiler pump (P1) provides flow through the boiler and ensures flow past the variable speed injection pump take-offs.

Mixing Demand (Mix 1) When heat is required in the Mix 1 zones, the zone valve end switches provide a *Mixing Demand* to the 356 and energizes relay R1. Relay R1 then turns on the boiler pump (P1) and mixing system pump (P3). The mixed supply water temperature is based on the *Characterized Heating Curve* settings. The 356 then controls the variable speed injection pump (P2) to supply the required system water temperature. As the variable speed injection pump begins to ramp up, the 356 uses its *Boiler* contact terminals (5 and 6) to send a Boiler Enable to the boiler's operating aquastat. While the 356's *Boiler* contact is made, the variable speed injection pump (P2) is also modulated to protect the boiler from excessively low water temperatures.

Mixing Demand (Mix 2) When heat is required in the Mix 2 zones, the zone valve end switches provide a *Mixing Demand* to the 356 and energizes relay R2. Relay R2 then turns on the boiler pump (P1) and mixing system pump (P5). The mixed supply water temperature is based on the *Characterized Heating Curve* settings. The 356 then controls the variable speed injection pump (P4) to supply the required system water temperature. As the variable speed injection pump begins to ramp up, the 356 uses its *Boiler* contact terminals (5 and 6) to send a Boiler Enable to the boiler's operating aquastat. While the 356's *Boiler* contact is made, the variable speed injection pump (P4) is also modulated to protect the boiler from excessively low water temperatures.

All control functions and specifications are listed in the Product Catalog I 000 and Data Brochure D 356.



tekmar Control Systems Ltd., Canada
 tekmar Control Systems, Inc., U.S.A.
Head Office: 5100 Silver Star Road
Vernon, B.C. Canada V1B 3K4
Tel. (250) 545-7749 Fax. (250) 545-0650
Web Site: www.tekmarcontrols.com





Mechanical

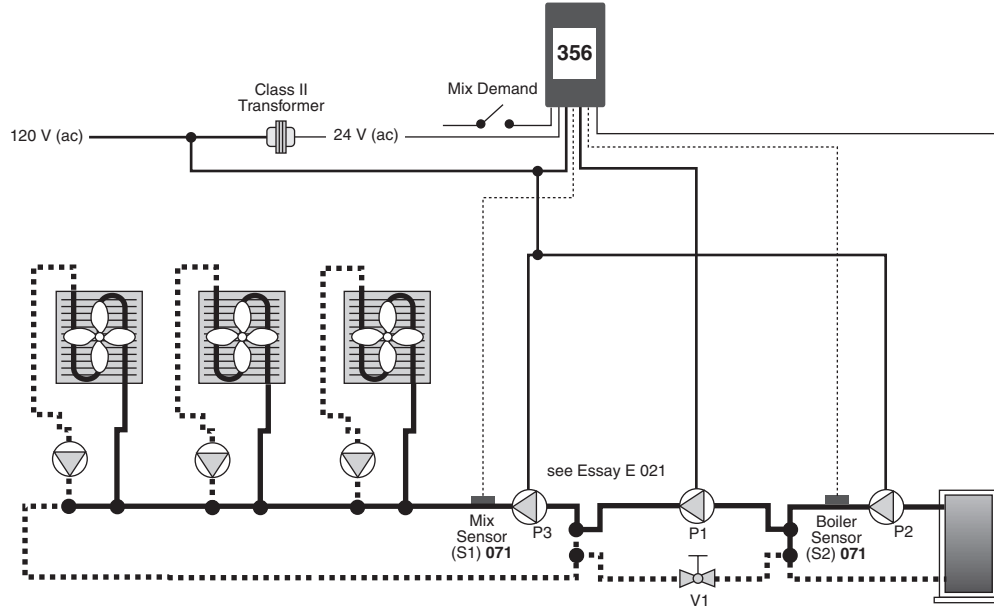

Electrical

- D1 = Mix Demand
- P1 = Variable Speed Injection Pump
- P2 = Boiler Pump
- P3 = Mixing System Pump
- S1 = Mix Supply Sensor 071
- S2 = Boiler Supply Sensor 071
- V1 = Balancing or Globe Valve

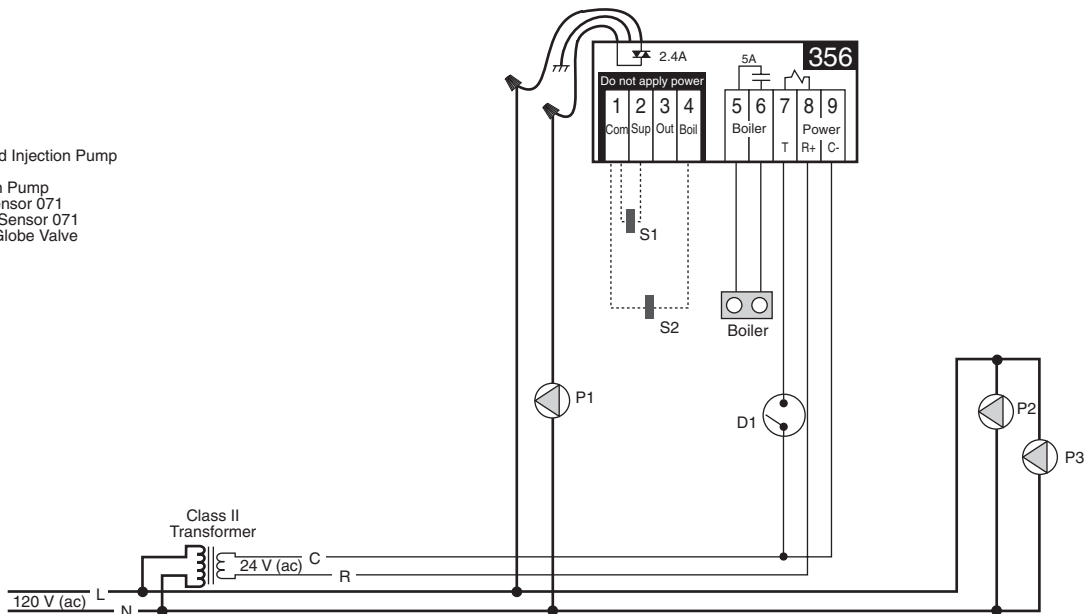

Note: This is only a concept drawing. The designer must determine whether this application will work in his system and must ensure compliance with code requirements. Necessary auxiliary equipment, isolation relays (for loads greater than the specified tekmar internal relay ratings), and other safety and limit devices must be added.

System Operation

The Mixing Control 356 provides setpoint control to fancoil zones. The output of the variable speed injection pump is modulated to provide a fixed water temperature to the zones, and protect the boiler from flue gas condensation. The boiler operates at the required temperature in order to satisfy the load.

Heat Source Details The heat source can be either a high mass or low mass non-condensing boiler.

Piping Details Fancoil units are piped into the mixed loop. The variable speed injection pump (P1) is piped in primary / secondary in order to isolate the boiler loop flow rate from the mixed loop flow rate. The boiler pump (P2) provides flow through the boiler and ensures flow past the variable speed injection pump take-off.

Mixing Demand When heat is required in the mixed zones, the mix demand switch provides a *Mixing Demand* to the 356. The mixed supply water temperature is fixed based on the MIX TARGET setpoint. The variable speed injection pump (P1) is then controlled to supply the required mixed supply water temperature. As the variable speed injection pump ramps up and requires more heat from the boiler, the boiler is fired to a temperature that is sufficient to satisfy the requirements of the variable speed injection pump. Whenever the boiler is fired, the 356 aims to maintain the boiler temperature above the BOIL MIN setting. While the boiler is firing, the variable speed injection pump is also modulated to protect the boiler from excessively low water temperatures.

All control functions and specifications are listed in the Product Catalog I 000 and Data Brochure D 356.



tekmar Control Systems Ltd., Canada
 tekmar Control Systems, Inc., U.S.A.
Head Office: 5100 Silver Star Road
Vernon, B.C. Canada V1B 3K4
Tel. (250) 545-7749 Fax. (250) 545-0650
Web Site: www.tekmarcontrols.com



Mechanical

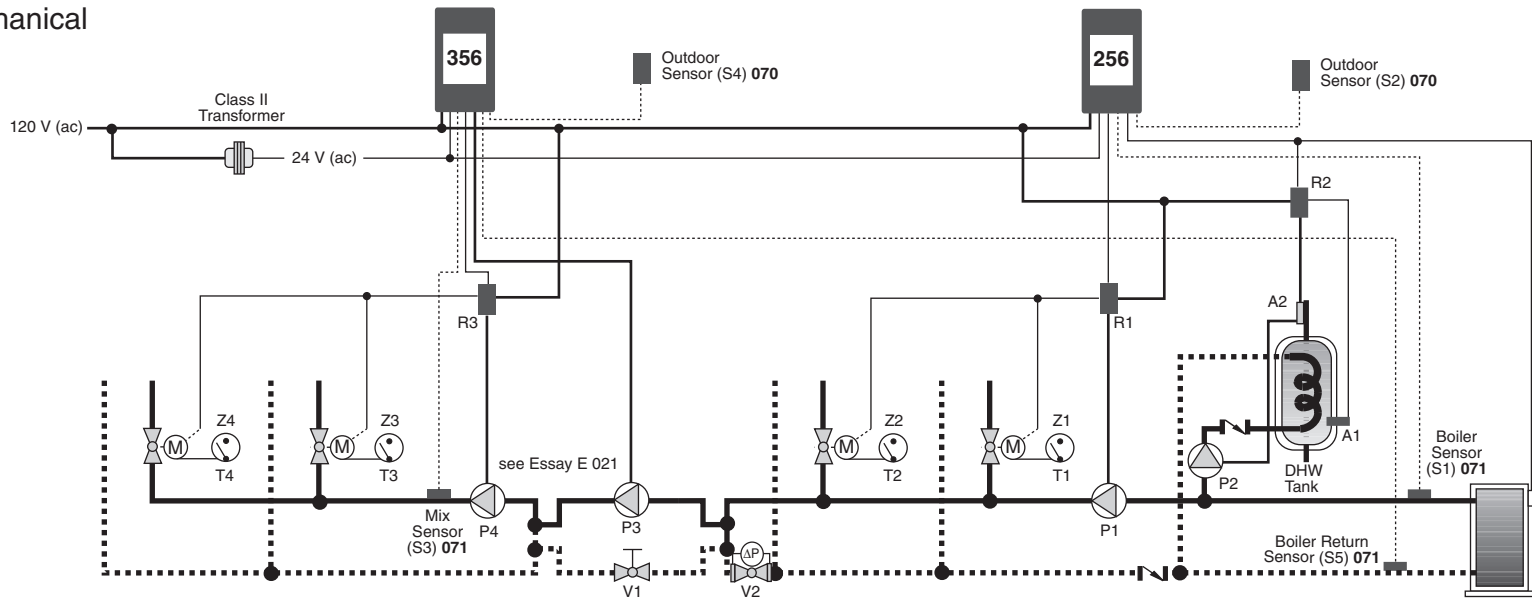

Electrical

- A1 = DHW Aquastat
- A2 = DHW High Limit Aquastat
- P1 = Boiler Pump
- P2 = DHW Pump
- P3 = Variable Speed Injection Pump
- P4 = Mixing System Pump
- R1, ..., R3 = Relay 003
- S1 = Boiler Supply Sensor 071
- S2, S4 = Outdoor Sensor 070
- S3 = Mix Supply Sensor 071
- S5 = Boiler Return Sensor (S5) 071
- T1, ..., T4 = Thermostats
- V1 = Balancing or Globe Valve
- V2 = Balancing Valve or Pressure Bypass Valve
- Z1, ..., Z4 = Zone Valve Motor End Switches

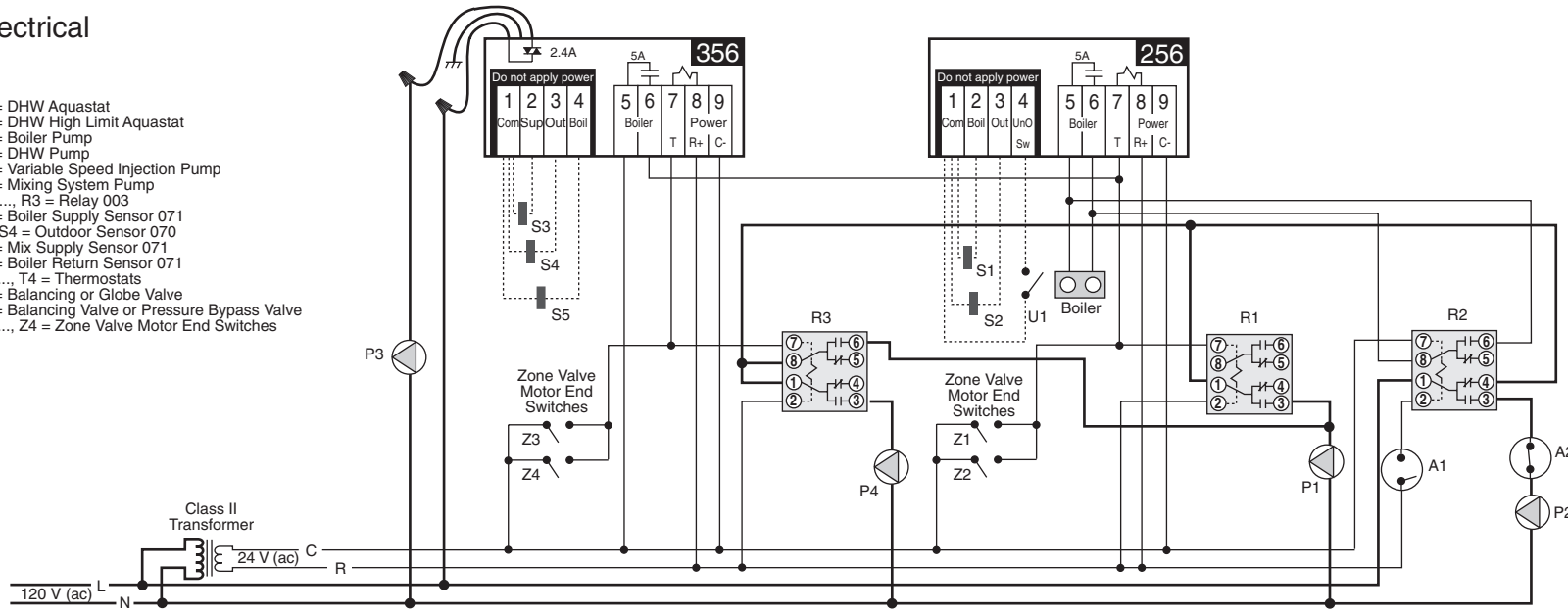

Note: This is only a concept drawing. The designer must determine whether this application will work in his system and must ensure compliance with code requirements. Necessary auxiliary equipment, isolation relays (for loads greater than the specified tekmar internal relay ratings), and other safety and limit devices must be added.

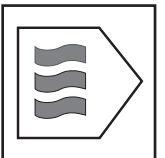

System Operation

The Mixing Control 356 and the Boiler Control 256 are combined to provide full outdoor reset to two (or more) mixed zones and partial outdoor reset to two (or more) boiler zones. The output of the variable speed injection pump is modulated to provide a mixed supply water temperature to the mixed zones, and protect the boiler from flue gas condensation. The boiler operates at the required temperature in order to satisfy all the loads. The supply of heat to an indirect Domestic Hot Water (DHW) tank is controlled through an external relay.

Heat Source Details The heat source can be either a high mass or low mass non-condensing boiler.

Piping Details Thermostat controlled zone valves are piped into the mixed loop. The variable speed injection pump (P3) is piped in primary / secondary in order to isolate the boiler loop flow rate from the mixed loop flow rate. Thermostat controlled zone valves are piped into the boiler loop. Heat is supplied to the DHW tank through a DHW pump (P2). The boiler pump (P1) provides flow through the boiler, and boiler zones, and ensures flow past the variable speed injection pump take-off. A balancing valve (V2) creates a pressure differential so that flow will occur through the boiler zones when those zone valves are open.

Domestic Hot Water (DHW) When the DHW tank requires heat, the DHW aquastat (A1) energizes relay R2. Relay R2 provides power to the DHW pump (P2) and turns off the boiler pump (P1) in order to provide DHW priority. Once energized, relay R2 also enables the boiler. The boiler is then allowed to operate up to the operating aquastat's setting.

Boiler Demand When heat is required in the boiler zones, the zone valve end switches send a *Boiler Demand* to the 256 and energizes relay R1. Provided the DHW aquastat (A1) is satisfied, relay R1 then turns on the boiler pump (P1). The boiler supply water temperature is based on the *Characterized Heating Curve* settings. The boiler is fired to satisfy the required boiler supply water temperature. Whenever the boiler is fired, the 256 aims to increase the boiler supply water temperature to at least the BOIL MIN setting.

Mixing Demand When heat is required in the mixed zones, the zone valve end switches send a *Mixing Demand* to the 356 and energizes relay R3. Provided the DHW aquastat (A1) is satisfied, relay R3 then turns on the boiler pump (P1) and mixing system pump (P4). The mixed supply water temperature is based on the *Characterized Heating Curve* settings. The variable speed injection pump (P3) is then controlled to supply the required mixed supply water temperature. As the variable speed injection pump ramps up, the 356 uses its *Boiler* contact (terminals 5 and 6) to send a *Boiler Demand* to the 256. While the 356 is sending a *Boiler Demand* to the 256, the variable speed injection pump (P3) is also modulated to protect the boilers from excessively low water temperatures.

All control functions and specifications are listed in the Product Catalog I 000 and Data Brochures D 356 and D 256.



tekmar Control Systems Ltd., Canada
 tekmar Control Systems, Inc., U.S.A.
Head Office: 5100 Silver Star Road
Vernon, B.C. Canada V1B 3K4
Tel. (250) 545-7749 Fax. (250) 545-0650
Web Site: www.tekmarcontrols.com

