

The One Stage Boiler Control 253 is a microprocessor-based control designed to regulate the supply water temperature from a single boiler based on the outdoor temperature. To avoid boiler short cycling and large temperature swings, the 253 is able to continuously adjust the boiler differential.

The 253 includes functions such as Warm Weather Shut Down (WWSO), Minimum Boiler setting, and a Starting Temperature setting. The control has a digital, liquid crystal display (LCD) that normally displays the Boiler Supply temperature, but can display other temperatures and settings.

Control Strategy pg. 1
Sequence of Operation pg. 2
Installation pg. 3
Settings pg. 4

Testing the Control pg. 6
Error Messages. pg. 7
Technical Data pg. 8
Limited Warranty pg. 8

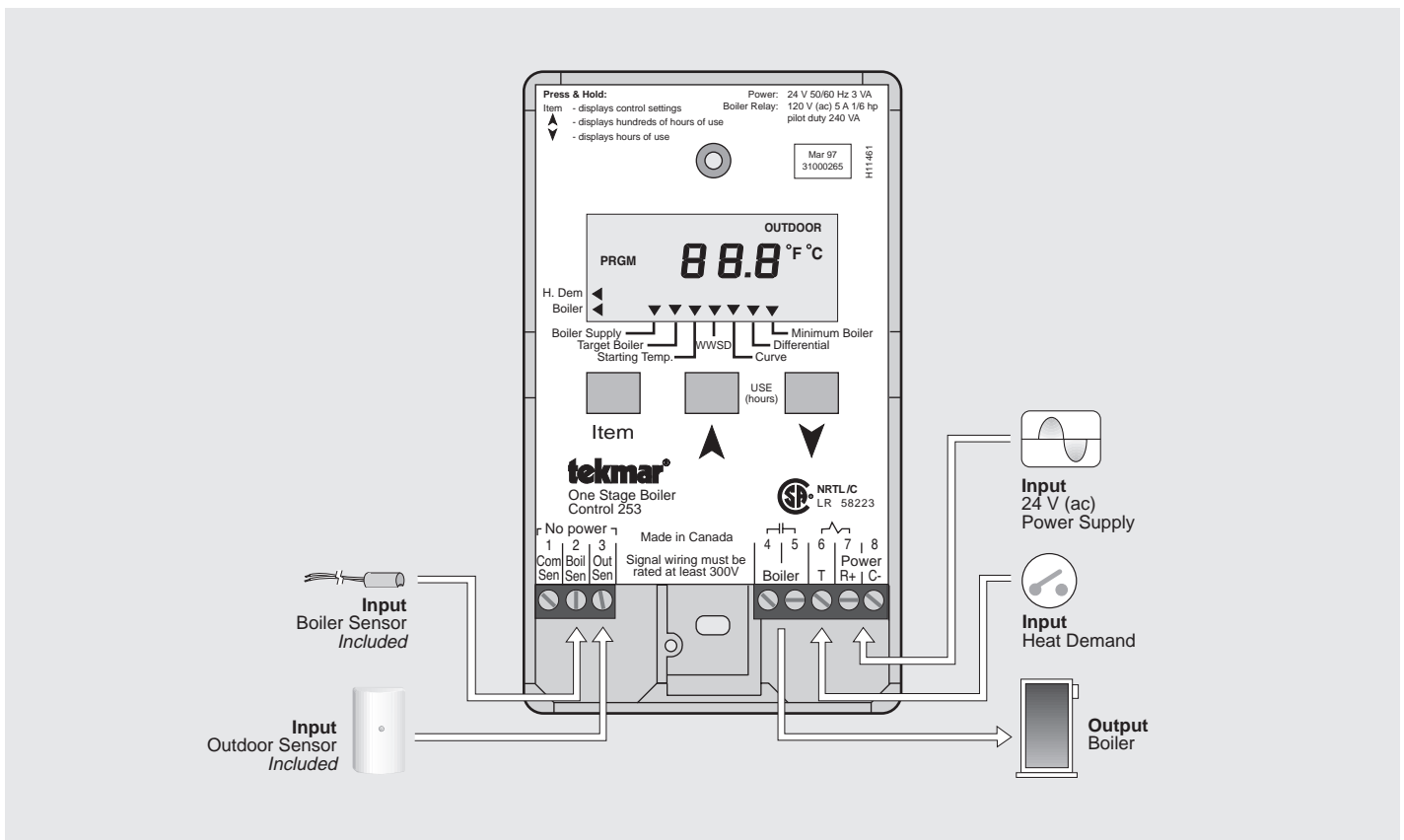

Control Strategy

OUTDOOR RESET

In order to properly control a hot water heating system, the heat supplied to the building must equal the heat lost by the building.

- The heat supplied to a building is proportional to the temperature of the supply water and the surface area of the heating element. A small surface area such as baseboard radiators requires a higher water temperature than a larger surface area such as radiant floors.
- The heat lost from a building is dependent on the outdoor temperature, as well as other factors. As the outdoor temperature drops, the building heat loss increases.

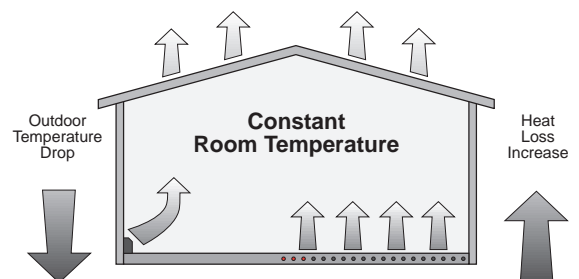

Heating Curve

Operation of a hot water heating system can generally be improved by modulating the supply water temperature as the outdoor temperature changes. Using this approach, the heat lost from the building is matched by the heat input to the building. A tekmar reset control utilizes a heating curve to set the relationship between outdoor temperature and supply water temperature. The heating curve determines the amount the supply water temperature is raised for every 1° drop in outdoor air temperature, and it is determined from the starting point and the system design conditions. The heating curve is sometimes called an outdoor reset ratio.

Heating Curve Starting Point

All heating curves begin at the heating curve starting point. This point is a combination of an adjustable starting water temperature setting and the WWSD point.

Starting Temperature

When the outdoor temperature is cold enough to start the heating system, the control should provide a preset starting supply water temperature. If the Starting Temperature setting is adjusted, the heating curve is shifted vertically.

Warm Weather Shut Down (WWSD)

When the outdoor air temperature is warmer than the Warm Weather Shut Down setting, no additional heat is required in the building; therefore, the heating system can be shut down. When the WWSD temperature is adjusted, the heating curve is shifted horizontally.

Starting Water Temperature Adjustment

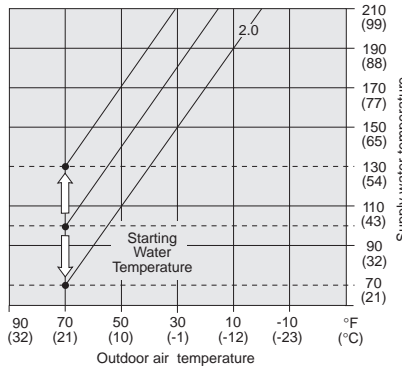

WWSD Adjustment

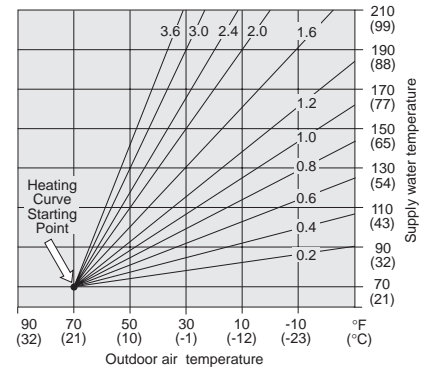
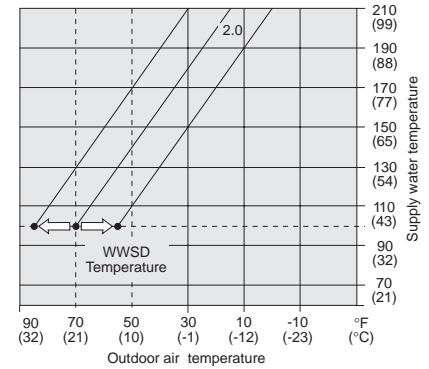

BOILER OPERATION

The supply water temperature from a boiler can be controlled by cycling the boiler on and off. Modulation of the boiler's operating temperature in hot water heating systems not only provides more comfort but also offers significant energy savings. The cooler the boiler runs, the more efficient it is due to less heat losses up the flue and reduced boiler jacket losses.

Minimum Boiler Supply

Most boilers require a minimum supply water temperature in order to prevent corrosion from flue gas condensation. The control should therefore only modulate the boiler supply water temperature down to the boiler manufacturer's minimum recommended operating temperature. Some boilers are designed to condense and should be operated at low water temperatures as much as possible for maximum efficiency.

Differential

An on / off boiler must be operated with a differential in order to prevent short cycling. When the supply water temperature drops below the bottom rail of the differential, the boiler is turned on. The boiler is then kept on until the supply water temperature rises above the top rail of the differential. If the differential is too wide, there can be large supply water temperature swings; however, if the differential is too narrow, the boiler short cycles and operates inefficiently. This control can automatically calculate the boiler differential in order to achieve an appropriate balance between temperature swings and boiler efficiency. This also permits the control to adapt to changing loads and conditions.

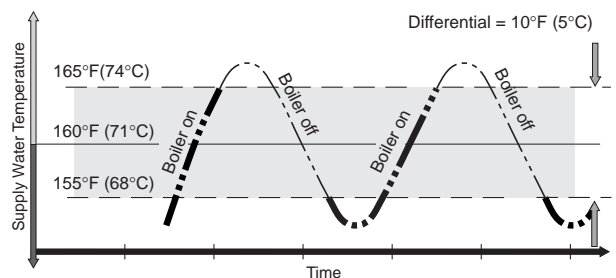
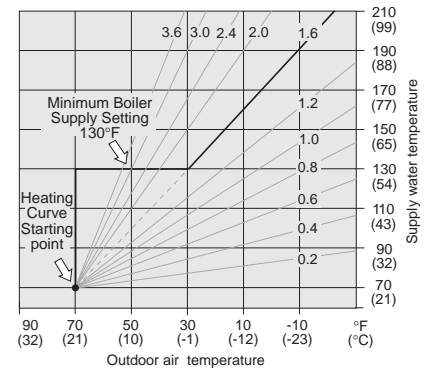

Sequence of Operation

POWERING UP THE CONTROL

After the 253 is powered up, a software version number is displayed and is followed by a test of all LCD segments. After 5 seconds the control displays the boiler supply water temperature.

HEAT DEMAND

The 253 requires a heat demand in order to control the boiler supply water temperature. When terminal *T* is connected to terminal *C*- (6 and 8), the control receives a heat demand. The *H. Dem* pointer flashes for up to 30 seconds and then turns on solid. The flashing represents a built in delay for turning on the boiler.

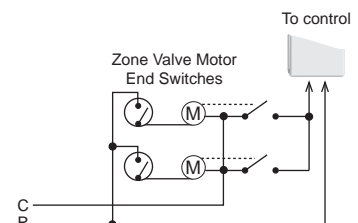

WARM WEATHER SHUT DOWN (WWSD)

When the outdoor temperature rises above the WWSD setting, the 253 flashes the *WWSD* pointer and turns off the *Boiler* relay (4 and 5).

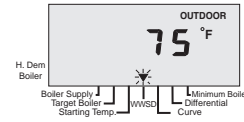

BOILER OPERATION

While the 253 has a heat demand, the system supply water temperature is controlled by turning the boiler on and off. The 253 calculates the target supply water temperature based on the outdoor temperature, the heating curve setting, the starting temperature setting, the WWSD setting, and the minimum boiler setting.

The boiler operates around a differential that is either manually set or automatically controlled by the 253. If the differential is manually fixed and a heat demand is present, there is a 60 second off time delay of the boiler to allow for prepurging of the system and prevention of boiler short cycling. The off time delay decreases to 20 seconds if the automatic differential is set. The automatic boiler differential increases system efficiency by adjusting to changing loads.

Maximum Boiler Supply

The 253 does not allow the target boiler supply water temperature to exceed 220°F (104°C) minus half the differential. If the boiler supply temperature reaches 220°F (104°C), the control turns off the boiler.

Minimum Boiler Supply

The 253 has a *Minimum Boiler* setting which selects a minimum target boiler supply temperature in order to prevent corrosion from flue gas condensation. During mild outdoor conditions, the boiler cycles around the minimum boiler setting. This programmed function has an *Off* setting for condensing and electric boilers. The control flashes the *Minimum Boiler* pointer when operating at the minimum setting.

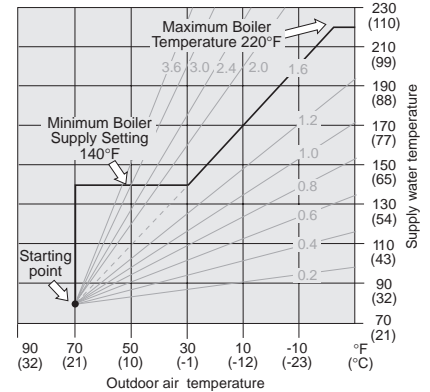

Installation

Caution

Improper installation and operation of this control could result in damage to the equipment and possibly even personal injury. It is your responsibility to ensure that this control is safely installed according to all applicable codes and standards. This electronic control is not intended for use as a primary limit control. Other controls that are intended and certified as safety limits must be part of the control circuit.

STEP ONE GETTING READY

Check the contents of this package. If any of the contents listed are missing or damaged, please contact your wholesaler or tekmar sales representative for assistance.

- Type 253 includes:
- One Stage Boiler Control 253
 - One Outdoor Sensor 070
 - One Universal Sensor 071
 - Data Brochures D 253, D 001, D 070
 - Application Brochures A 253

Other information available:

- Essays

Note Carefully read the details of the *Sequence of Operation* section in this brochure to ensure that you have chosen the proper control for your application.

STEP TWO MOUNTING

The control is mounted in accordance with the instructions in the Data Brochure D 001.

STEP THREE ROUGH-IN WIRING

All electrical wiring terminates in the two wiring chambers on the control. If the control is to be mounted on an electrical box, the wiring can be roughed-in at the electrical box prior to installation of the control. (See Brochure D 001.) Standard 18 AWG solid wire is recommended for all low voltage wiring.

Power must not be applied to any of the wires during the rough-in wiring stage.

- Install the Outdoor Sensor 070 and the Universal Sensor 071 according to the instructions in the Data Brochure D 070 and run the wiring back to the control mounting location.
- Run the wiring from the boiler to the control mounting location.
- Run the wires from the heat demand circuit to the control mounting location.
- Run the wires from the 24 V (ac) power source to the control mounting location. **Use a clean power source to ensure proper operation.**

STEP FOUR TESTING THE WIRING

No wires should be connected to the control during testing.

A good quality electrical test meter, capable of reading from at least 0 — 200 V (ac) and at least 0 — 2,000,000 Ohms, is essential to properly test the wiring and sensors.

Test the Sensors

Test the sensors according to the testing procedure in Data Brochure D 070. Ensure the sensor wires are not connected to the control terminals.

Test the Power Supply

Make sure exposed wires and bare terminals are not in contact with other wires or grounded surfaces. Turn on the power and measure the voltage across the 24 V (ac) power supply. The voltmeter should read between 22 and 26 Volts.

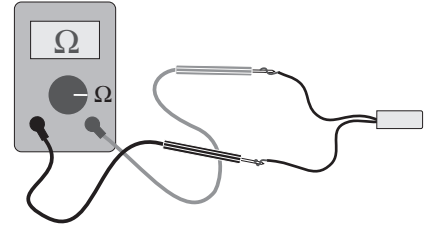

Test the Powered Inputs

Measure the voltage between the heat demand wire and the power wire that goes to C- of the control. The voltmeter should read between 22 and 26 volts when there is a call for heat.

Test the Outputs

Short the boiler wires and power up the boiler circuit; the boiler should fire. Remove power from the boiler circuit.

STEP FIVE ELECTRICAL CONNECTIONS TO THE CONTROL

The installer should confirm that no voltage is present at any of the wires.

Output Connections

Boiler Relay

Connect the 120 V (ac) or 24 V (ac) boiler circuit directly to the *Boiler* relay (4 and 5) terminals. These terminals go to dry relay contacts.

Powered Input Connections

24 V (ac) Power

Connect the 24 V (ac) power supply to terminals *Power R+*—*C-* (7 and 8) on the control.

Heat demand

Connect the C- side of the transformer to terminal *T* (6) through a switching device. This provides a heat demand to the control.

Caution The C- of the same transformer used to power up the control must be used to provide the heat demand.

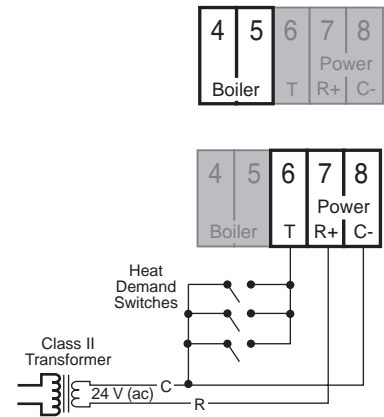

Sensor and Unpowered Input Connections

Do not apply power to these terminals as this will damage the control.

Outdoor Sensor

Connect the two wires from the Outdoor Sensor 070 to the terminals *Com Sen* — *Out Sen* (1 and 3). The Outdoor Sensor measures the outdoor air temperature.

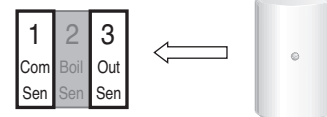

Boiler Sensor

Connect the two wires from the Boiler Sensor 071 to the terminals *Com Sen* — *Boil Sen* (1 and 2). The Boiler Sensor measures the supply water temperature going from the boiler to the system.

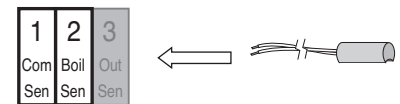

Settings

Before adjusting the settings, read through the sequence of operation to ensure that you understand how the control operates. The following page describes how to program these settings into the control once it has been powered up.

STEP SIX ESSENTIAL CONTROL SETTINGS

Starting Temp.

The *Starting Temp.* setting is the starting supply water temperature of the heating curve, and can be adjusted from 35 to 150°F (2 to 66°C). In applications where fan coils are used, the *Starting Temp.* may need to be set higher to prevent cold drafts.

Warm Weather Shut Down (WWSD)

The WWSD can be adjusted from 35 to 85°F (2 to 29°C). The boiler will be shut down when the outdoor temperature is warmer than this setting. Factory setting is 68°F (20°C).

Differential

The differential adjustment sets how far the actual boiler supply water temperature may deviate from the desired temperature before the boiler is turned on or off, and it is determined by the flow rate through the system pump relative to the heat output by the boiler. The Differential can be adjusted to Ad (Auto differential) or from 2 to 42°F (1 to 23°C). The following formula can be used to calculate the desired differential:

$$\text{Differential} = \frac{\text{Btu/hr input}}{\text{System US GPM} \times 50} \quad \text{Example: } \frac{100,000 \text{ Btu/hr}}{20 \text{ US GPM} \times 50} = 10^\circ\text{F (6}^\circ\text{C)}$$

When the adjustment is set to *Ad (Auto Differential)*, the differential is continuously calculated by the control, and varies as the heating load changes. This setting is suggested and therefore it is a factory setting.

Minimum Boiler Supply

Most boilers require a minimum operating temperature to prevent corrosion from flue gas condensation. The *Minimum Boiler* setting should be programmed to the lowest supply water temperature at which the boiler can operate without causing the boiler flue gases to condense. Consult the boiler manufacturer for recommended minimum boiler supply temperatures. Some typical settings are as follows:

- Steel fire tube boiler 140 to 160°F (60 to 71°C)
- Cast iron boiler 135 to 160°F (57 to 71°C)
- Copper tube boiler 125 to 150°F (52 to 66°C)
- Condensing boiler Off
- Electric boiler Off

Curve (Heating Curve)

The Heating Curve setting determines the number of degrees the supply water temperature is raised for every one degree drop in outdoor temperature. The *Curve* setting can be calculated from the following formula.

$$\text{Heating Curve} = \frac{\text{design supply temperature} - \text{Starting water temperature}}{\text{WWSD} - \text{design outdoor temperature}}$$

Curve (Heating Curve) Setting Examples:

	Example #1	Example #2	Example #3
Design Supply Water Temperature	180°F (82°C)	180°F (82°C)	180°F (82°C)
Starting Water Temperature	70°F (21°C)	150°F (66°C)	160°F (71°C)
Design Outdoor Temperature	-5°F (-21°C)	-5°F (-21°C)	-5°F (-21°C)
Warm Weather Shut Down (WWSD)	70°F (21°C)	65°F (18°C)	60°F (16°C)
Minimum Boiler	130°F (54°C)	130°F (54°C)	130°F (54°C)

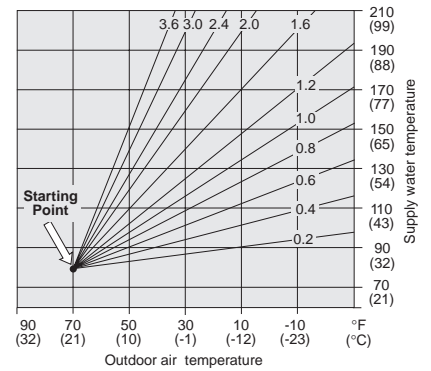

Example #1

$$\text{Heating Curve} = \frac{180 - 70^\circ\text{F (82} - 21^\circ\text{C)}}{70 - (-5^\circ\text{F) (21} - (-21^\circ\text{C)}} = \frac{110^\circ\text{F (61}^\circ\text{C)}}{75^\circ\text{F (42}^\circ\text{C)}} = 1.5$$

Example #2

$$\text{Heating Curve} = \frac{180 - 150^\circ\text{F (82} - 66^\circ\text{C)}}{65 - (-5^\circ\text{F) (18} - (-21^\circ\text{C)}} = \frac{30^\circ\text{F (16}^\circ\text{C)}}{70^\circ\text{F (39}^\circ\text{C)}} = 0.4$$

Example #3

$$\text{Heating Curve} = \frac{180 - 160^\circ\text{F (82} - 71^\circ\text{C)}}{60 - (-5^\circ\text{F) (16} - (-21^\circ\text{C)}} = \frac{20^\circ\text{F (11}^\circ\text{C)}}{65^\circ\text{F (37}^\circ\text{C)}} = 0.3$$

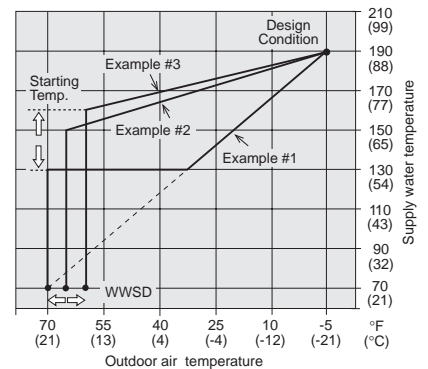

Control Adjustments

Starting Temp.: _____

WWSD: _____

Curve: _____

Differential: _____

Minimum Boiler: _____

POWER ON

When the control is powered-up, a version number followed by all display elements are turned on. After approximately 5 seconds, the control automatically goes into operating mode.

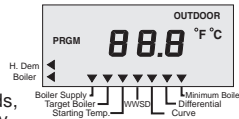

Once in operating mode, the control will display the boiler supply temperature and will turn on the *Boiler Supply* pointer.

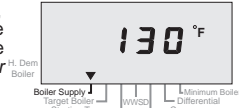

The control will flash the *WWS* pointer if the outdoor temperature is greater than the *WWS* setting. If the control is operating at minimum, the *Minimum Boiler* pointer will flash.

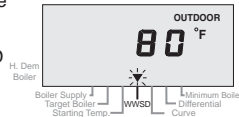

VIEWING

Target Boiler Supply Temperature

Press and Release the "Item" button. The target boiler temperature and the *Target Boiler* pointer will be displayed. A series of lines are displayed if no heat is required.

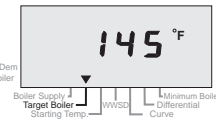

Outdoor Temperature

Press and Release the "Item" button until the *Outdoor* element is turned on. The Outdoor temperature will be displayed.

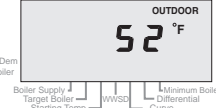

Actual Boiler Supply Temperature

Press and Release the "Item" button until the *Boiler Supply* pointer is turned on. The Boiler Supply temperature will be displayed.

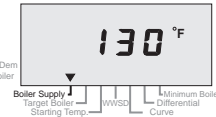

Programmed Settings

Press and Hold the "Item" button. The programmed settings will be displayed sequentially.

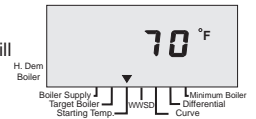

Boiler Running Hours

Press and Hold the ∇ button. The boiler hours (xx) of use will be displayed. Press and Hold the \blacktriangle button. The hundreds of boiler hours (xx00) of use will be displayed.

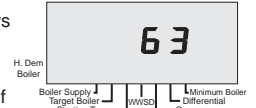

Clearing Boiler Running Hours

Press and Hold the ∇ and \blacktriangle buttons for 3 seconds to clear the boiler hours of operation.

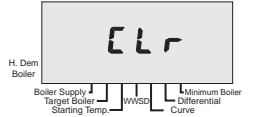

PROGRAMMING

To enter the programming mode Press and Hold simultaneously, the "Item", ∇ , and \blacktriangle buttons. The PRGM element will turn on.

Starting Temperature

Once in the PRGM mode, the programmed *Starting Temp.* pointer will flash. Use the ∇ and \blacktriangle buttons to set the desired starting temperature

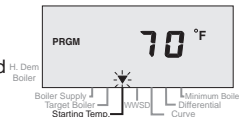

WWS

Press and Release the "Item" button until the *WWS* pointer flashes. Use the ∇ and \blacktriangle buttons to set the desired temperature.

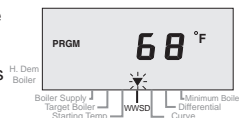

Heating Curve

Press and Release the "Item" button until the *Curve* pointer flashes. Use the ∇ and \blacktriangle buttons to set the desired ratio.

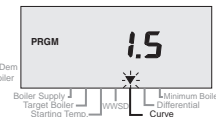

Differential

Press and Release the "Item" button until the *Differential* pointer flashes. Use the ∇ and \blacktriangle buttons to set the control into *Ad* (auto differential) or a fixed value.

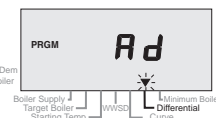

Minimum Boiler

Press and Release the "Item" button until the *Minimum Boiler* pointer flashes. Use the ∇ and \blacktriangle buttons to set the desired temperature.

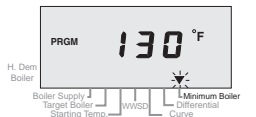

Fahrenheit / Celsius

Press and Release the "Item" button until the $^{\circ}\text{F}$ or $^{\circ}\text{C}$ element flashes. Use the ∇ and \blacktriangle buttons to set the scale to $^{\circ}\text{F}$ or $^{\circ}\text{C}$.

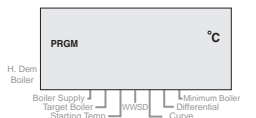

The control automatically goes back to viewing when the buttons are left alone for 20 seconds

All settings will be saved even during power down of the control

Testing the Control

STEP SEVEN TESTING

If testing is required with the One Stage Boiler Control 253, follow the testing procedure in step four of the installation procedure on page 4 of this brochure.

STEP EIGHT TROUBLESHOOTING

As in any troubleshooting procedure, it is important to isolate a problem as much as possible before proceeding. The Error Messages greatly simplify troubleshooting of the 253. When the control displays an error message, identify the fault from the look-up table on page 7 and follow standard testing procedures to confirm the problem. If you suspect a wiring fault, return to steps three, four and five and carefully check all external wiring and wiring connections.

Sensor and Internal Faults

- If an outdoor sensor fault occurs, the 253 will assume a fixed outdoor temperature of 32°F (0°C) and will target the appropriate supply water temperature. An error message is displayed.
- If a supply sensor fault occurs, the 253 turns the boiler off and displays an error message.
- If an internal control fault occurs, the 253 operates as normal but displays an error message.

Adjustment of Settings

- If the outdoor temperature is cold and the rooms are cold, increase the *Curve* setting by 0.1 per day.
- If the outdoor temperature is near the WWSD temperature and the rooms are cold, increase the *Starting Temp.* setting.
- If the boiler is cycling too often, increase the *Differential* setting or set control to *Ad* (Auto Differential).

STEP NINE BEFORE YOU LEAVE

- Install the wiring cover over the wiring chamber and secure it with the screw provided.
- Place the front cover on the control and snap it into place.
- Place this brochure, and all other brochures relating to the installation, in the protective plastic bag supplied with the control.
- Place the bag in a conspicuous location near the control for future reference.
- It is important to explain the operation of this control within the system to the end user, and to anyone else who may be operating the system.

Error Messages

Whenever a fault is detected, an error message will be displayed to indicate the location of the problem. For detailed sensor testing instructions see Data Brochure D 070.

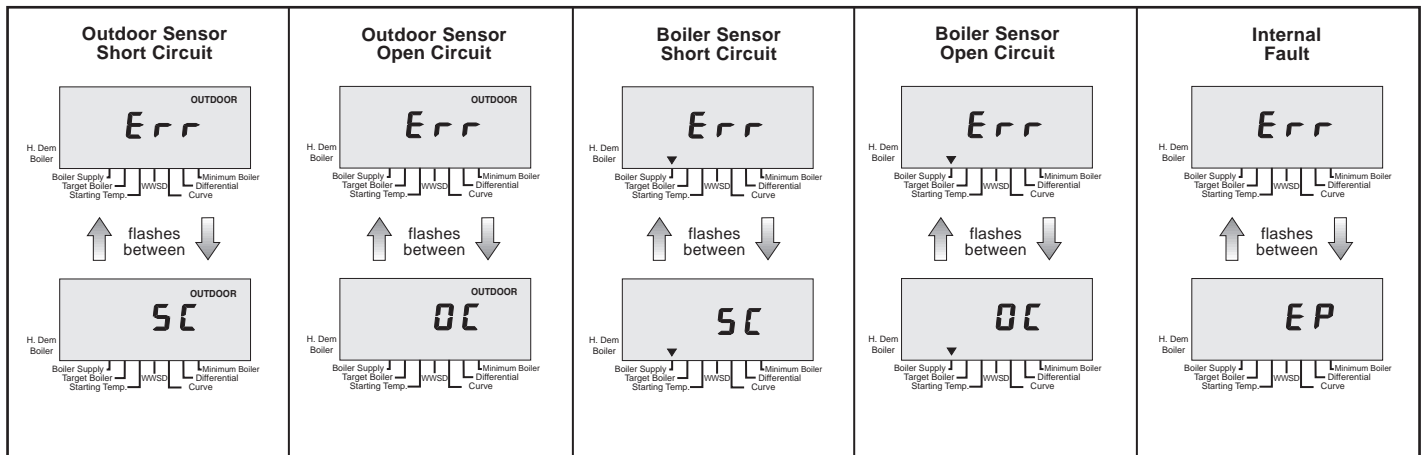

Refer to the troubleshooting section above for operation details

Notes

Technical Data

One Stage Boiler Control 253

Literature	— A 000, A 253's, D 253, D 001, D 070
Control	— Microprocessor PI control; This is not a safety (limit) control .
Packaged weight	— 1.1 lb. (500 g), Enclosure C, PVC plastic
Dimensions	— 4-3/4" H x 2-7/8" W x 7/8" D (120 x 74 x 22 mm)
Approvals	— CSA NRTL /C; Meets ICES & FCC regulations for EMI/RFI.
Ambient conditions	— Indoor use only, 15 to 120°F (-10 to 50°C), < 90% RH non-condensing.
Power supply	— Class 2, 24 V ±10% 50/60 Hz 3 VA
Relays	— 120 V (ac) 5 A 1/6 hp, pilot duty 240 VA 2 A
Sensors included:	— NTC thermistor, 10 kW @ 77°F (25°C ±0.2°C) β=3892 Outdoor Sensor 070 and Universal Sensor 071.
Starting Temp.	— 35 to 150°F (2 to 66°C)
WWSD	— 35 to 85°F (2 to 29°C)
Curve	— 0.2 to 3.6
Differential	— Auto, 2 to 42°F (Auto, 1 to 24°C)
Minimum Boiler	— Off, 70 to 170°F (Off, 21 to 77°C)

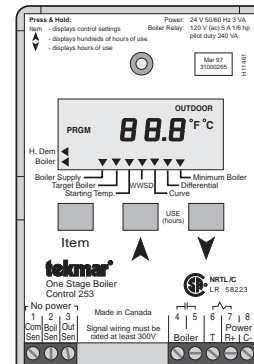

The installer must ensure that this control and its wiring are isolated and/or shielded from strong sources of electromagnetic noise. Conversely, this Class B digital apparatus complies with Part 15 of the FCC Rules and meets all requirements of the Canadian Interference-Causing Equipment Regulations. However, if this control does cause harmful interference to radio or television reception, which can be determined by turning the control off and on, the user is encouraged to try to correct the interference by reorienting or relocating the receiving antenna, relocating the receiver with respect to this control, and/or connecting the control to a different circuit from that to which the receiver is connected.

Cet appareil numérique de la classe B respecte toutes les exigences du Règlement sur le matériel brouilleur du Canada.

Limited Warranty and Product Return Procedure

Limited Warranty The liability of tekmar Control Systems Ltd. and tekmar Control Systems, Inc. ("tekmar") under this warranty is limited. Please read and understand the conditions appearing herein.

tekmar warrants each tekmar product against defects in workmanship and materials, when the product is installed and used in compliance with tekmar's instructions. The warranty period is for a period of twenty-four (24) months from the production date if the product is not installed during that period, or twelve (12) months from the documented date of installation if installed within twenty-four (24) months from the production date, but in any event the warranty period shall not extend beyond thirty-six (36) months from the production date. During the warranty period, tekmar will, at its discretion, either repair at no charge, exchange or give credit for the defective product, provided the product is returned to tekmar.

The liability of tekmar shall be limited to the cost of parts and labour provided by tekmar to correct defects in materials and / or workmanship or to the exchange of the defective product for a replacement product or to the granting of credit limited to the original cost of the product, at tekmar's discretion, and such repair, exchange or credit shall be deemed to be the sole remedy available from tekmar. This warranty does not cover the cost of the parts or labour to remove or to transport the defective product, or to reinstall the repaired or replacement product. Returned products that are not defective are not covered by this warranty.

This warranty does not apply if the product has been damaged by accident, abuse, misuse, negligence, fire, Act of God, or has been damaged by modifications, alterations or attachments made subsequent to purchase which have not been authorized by tekmar, or if the product was not installed in compliance with the local codes and ordinances, or if due to defective installation of the product.

The warranty applicable to a product is as set out in the statement of warranty policy (the "Warranty") above, receipt of which is hereby acknowledged. The liability of tekmar is limited to those obligations identified in the warranty as obligations of tekmar. The warranty is understood to be in substitution for any loss, costs or damages for which tekmar might otherwise be liable at law or in equity and in particular, in lieu of any liability for fundamental breach of contract.

tekmar disclaims any responsibility for losses, expenses, inconveniences, or any special, indirect, secondary, incidental or consequential damages arising from ownership or use of any items subject to any claim hereunder, regardless of whether such claim is stated in contract, tort or strict product liability.

This warranty is in lieu of all other warranties, express or implied, including, without limitation, warranties of merchantability, fitness for a particular purpose, durability or description of the product, its non-infringement of any relevant patents or trademarks, and its compliance with or non-violation of any applicable environmental, health or safety legislation. No implied warranties shall extend beyond twenty-four (24) months from the production date.

Some states or provinces do not allow limitations on how long an implied warranty lasts, so the above limitation may not apply to you. This warranty gives you specific legal rights, and you may also have other rights which vary from state to state or province to province.

Product Return Procedures Products that are believed to have defects in workmanship or materials must be returned, together with a written description of the defect, to the tekmar representative for that territory. If the address of the representative is not known, please request it from tekmar at the telephone number listed below.



tekmar Control Systems Ltd., Canada
tekmar Control Systems, Inc., U.S.A.
Head Office: 4611 - 23rd Street
Vernon, B.C. Canada V1T 4K7
Tel. (250) 545-7749 Fax. (250) 545-0650