

## For Commercial Applications

Job Name \_\_\_\_\_  
 Job Location \_\_\_\_\_  
 Engineer \_\_\_\_\_  
 Approval \_\_\_\_\_  
 Tag \_\_\_\_\_

Contractor \_\_\_\_\_  
 Approval \_\_\_\_\_  
 Contractor's P.O. No. \_\_\_\_\_  
 Representative \_\_\_\_\_

# ISCA-101-L/R

## Industry Standard Single Horizontal Adjustable Closet Carrier Specification

Watts ISCA-101-L/R *Industry Standard* single horizontal adjustable water closet carrier with epoxy coated cast iron fitting, 4"(102) no hub waste and 2"(51) no hub vent connections, epoxy coated cast iron patented compression seal faceplate assembly, and epoxy coated cast iron foot supports with incremental height markings. Adjustable for standard and wheelchair height, adjustable ABS nipple with integral test cap and neoprene bowl gasket, plated hardware and chrome cap nuts. Carrier complies with requirements of ASME A112.6.1M up to a 500 lb. (227 kg.) static load.

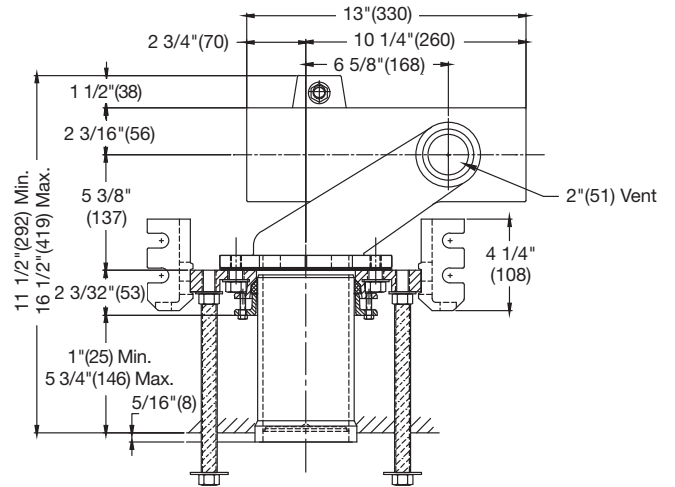

Options (Select One or More)	
Suffix	Description
-3	3" No Hub Fitting <input type="checkbox"/>
-36	36" Long Barrel Fitting <input type="checkbox"/>
-CA-100-EXT	Aux. Support System w/Extended Nipple <input type="checkbox"/>
-CI	Cast Iron Nipple <input type="checkbox"/>
-HS	Hub & Spigot Connections <input type="checkbox"/>
-M1	ABS Extended Nipple (Up to 24") <input type="checkbox"/>
-M11	Tiling Frame <input type="checkbox"/>
-M20	Flush Valve Support <input type="checkbox"/>

**Please refer to watts.com for BAA information on specific models.**

**NOTICE**

Anchor legs to concrete floor with minimum 1/2"(13) anchor bolts (by others).  
 Dual slotted carrier feet require one 1/2"(13) anchor bolt per foot.

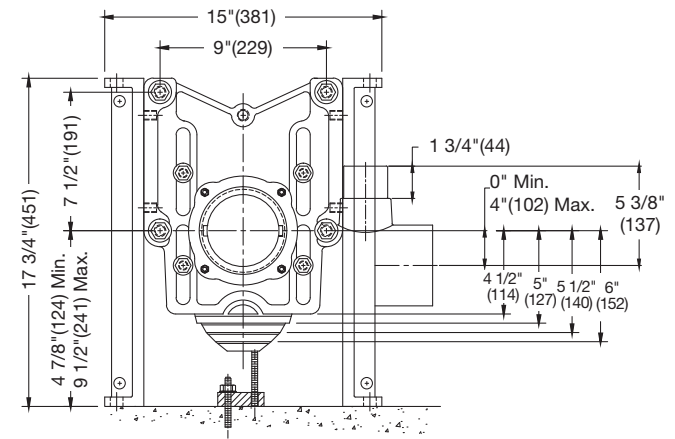

Note: Left hand carrier shown; right hand carrier is mirror image

**NOTICE**

The information contained herein is not intended to replace the full product installation and safety information available or the experience of a trained product installer. You are required to thoroughly read all installation instructions and product safety information before beginning the installation of this product.

Watts product specifications in U.S. customary units and metric are approximate and are provided for reference only. For precise measurements, please contact Watts Technical Service. Watts reserves the right to change or modify product design, construction, specifications, or materials without prior notice and without incurring any obligation to make such changes and modifications on Watts products previously or subsequently sold.



**USA:** T: (800) 338-2581 • F: (828) 248-3929 • Watts.com  
**Canada:** T: (888) 208-8927 • F: (888) 479-2887 • Watts.ca  
**Latin America:** T: (52) 55-4122-0138 • Watts.com