

Engineering Specification

Job Name _____

Contractor _____

Job Location _____

Approval _____

Engineer _____

Contractor's P.O. No. _____

Approval _____

Representative _____

Tag _____

FS55 Porcelain Enameled Cast Iron Floor Sink

Specifications

Watts Light Commercial FS55 12" (305) square x 6" (152) deep white porcelain enamel coated cast iron floor sink with loose set grate, and aluminum dome bottom strainer.



Pipe Sizing		
Suffix	Description	
-2NH	2"(51) No Hub	<input type="checkbox"/>
-2PT	2"(51) Push-On	<input type="checkbox"/>
-3NH	3"(76) No Hub	<input type="checkbox"/>
-3PT	3"(76) Push-On	<input type="checkbox"/>
-4NH	4"(102) No Hub	<input type="checkbox"/>
-4PT	4"(102) Push-On	<input type="checkbox"/>

Options		
Suffix	Description	
-2G	1/2 Grate	<input type="checkbox"/>
-3G	3/4 Grate	<input type="checkbox"/>
-B	Sediment Bucket	<input type="checkbox"/>
-G	CI Round Funnel	<input type="checkbox"/>
-GNB	NB Round Funnel	<input type="checkbox"/>
-H	CI Oval Funnel	<input type="checkbox"/>
-HNB	NB Oval Funnel	<input type="checkbox"/>
-LG	Less Grate	<input type="checkbox"/>
-NB	Nickel Bronze Top	<input type="checkbox"/>
-VP	Vandal Proof Screws (w/-NB Only)	<input type="checkbox"/>

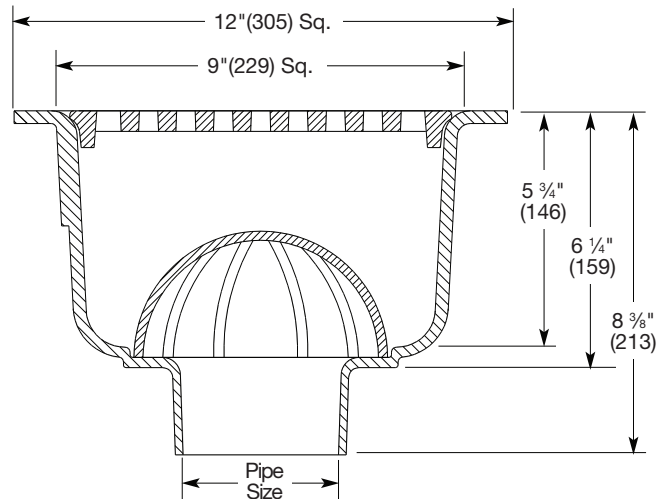

FS55

NOTICE

The information contained herein is not intended to replace the full product installation and safety information available or the experience of a trained product installer. You are required to thoroughly read all installation instructions and product safety information before beginning the installation of this product.

Watts product specifications in U.S. customary units and metric are approximate and are provided for reference only. For precise measurements, please contact Watts Technical Service. Watts reserves the right to change or modify product design, construction, specifications, or materials without prior notice and without incurring any obligation to make such changes and modifications on Watts products previously or subsequently sold.



USA: T: (800) 338-2581 • F: (828) 248-3929 • Watts.com

Canada: T: (888) 208-8927 • F: (888) 479-2887 • Watts.ca

Latin America: T: (52) 55-4122-0138 • Watts.com