

Installation, Operation and Maintenance

1½" Commercial Water Softener Systems

Series: CWS-150 & CWSTA-150



CWS-150 Simplex Systems

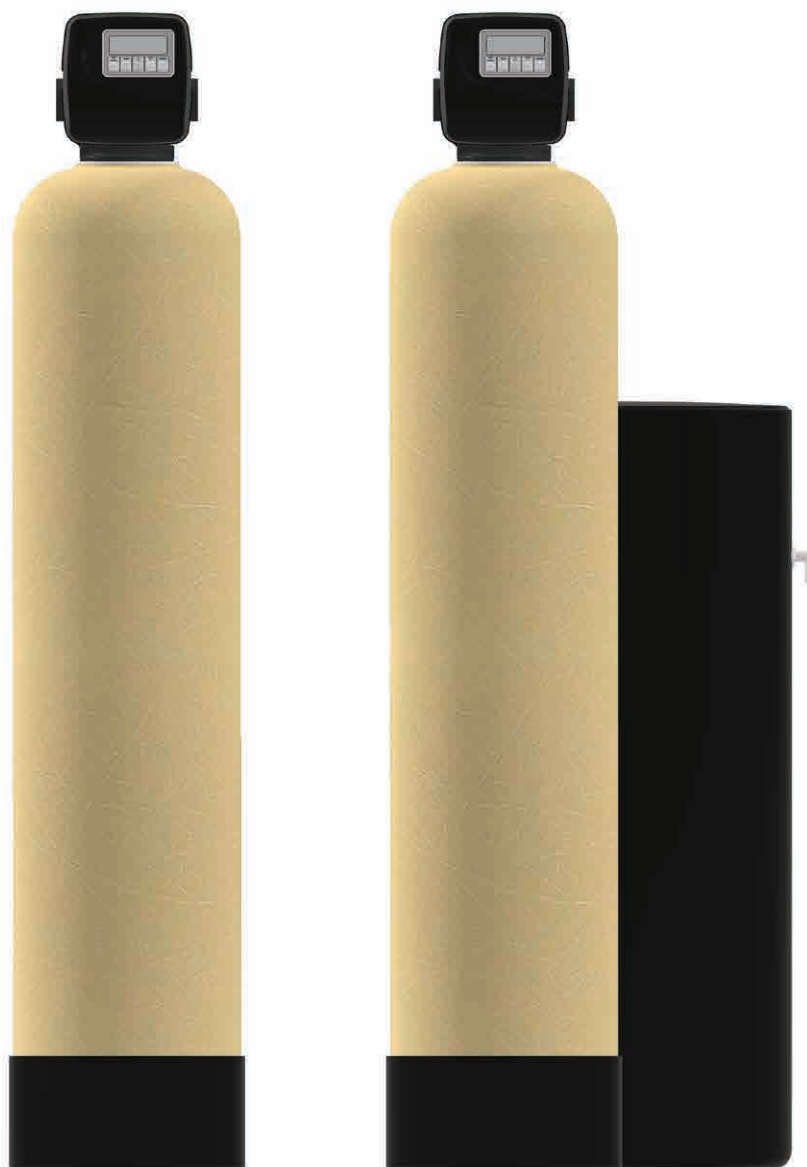

CWSTA-150 Duplex Alternating Systems

Congratulations on your purchase of this Watts® commercial water softening solution.

You have made a great choice to protect your plumbing system against the damaging effects of hard water. This system has been engineered for trouble free operation and produced using top quality components. Simple programming, corrosion resistant mineral tank(s) and an easy to service design ensures this system will be durable and easy to maintain.

Thank You!

The Watts Team

Softened water provides a wide variety of benefits such as reducing the potential of lime scale formation in boilers, water heaters and heat exchangers to protecting the remainder of the plumbing system from costly maintenance and down time associated with the negative effects of hard water.

⚠ WARNING

Please read carefully before proceeding with installation. Your failure to follow any attached instructions or operating parameters may lead to the product's failure. Keep this Manual for future reference.

**⚠ WARNING**

If you are unsure about installing your Watts water softener contact a Watts representative or consult a professional water treatment dealer or plumber.

You are required to thoroughly read all installation instructions and product safety information before beginning the installation of this product. **FAILURE TO COMPLY WITH PROPER INSTALLATION AND MAINTENANCE INSTRUCTIONS COULD RESULT IN PRODUCT FAILURE WHICH CAN CAUSE PROPERTY DAMAGE, PERSONAL INJURY AND/OR DEATH.** Watts is not responsible for damages resulting from improper installation and/or maintenance. Local building or plumbing codes may require modifications to the information provided. You are required to consult the local building and plumbing codes prior to installation. If this information is not consistent with local building or plumbing codes, the local codes should be followed.

Save manual for future reference.

Refer to the enclosed for operating parameters to ensure proper use with your water supply.

- As with all plumbing projects, it is recommended that a trained professional water treatment dealer or contractor install the water conditioning system. Please follow all local plumbing codes for installing this water conditioning system.
- Inspect the water conditioning system for carrier shortage or shipping damage before beginning installation. Replace any damaged component immediately, before beginning installation.
- Use caution when installing soldered metal piping near the water conditioning system. Heat can adversely affect the system's components.
- Use only lead-free solder and flux for sweat-solder connections, as required by state, province and federal codes.
- Handle all components of the system with care. Do not drop, drag or turn components upside down.
- Be sure the floor under the system is clean, level and strong enough to support the system while in operation.
- Install the system in a protected area.
- Do not attempt to treat water over 110°F (43°C) or under 34°F (1°C) with the system.
- Always connect the system to the main water supply pipe before the water heater.
 - The valve will withstand transportation and storage temperatures of -13 °F (-25 °C) to 131 °F (55 °C) and for short periods up to 158 °F (70 °C). If valve has been exposed to freezing conditions let valve warm up to room temperature before running water through it. The valve has been packaged to prevent damage from the effects of normal humidity, vibration and shock.
- Do not install in direct sunlight as overheating of electronics may occur and ultraviolet rays from the sun may cause damage.
- Operating ambient temperature: 34° to 120°F (1° to 52°C).
- Operating water pressure range : 25 to 125psi (171 kPa to 8.6 bar).

- All plumbing connections to the system should be made using industry accepted best practices. Plumbing tape or paste may be used on metal inlet and outlet plumbing connections. Do not use paste type pipe thread sealants on the system's plastic plumbing connections.
- Do not use petroleum-based lubricants such as Vaseline®*, oils or hydrocarbon-based lubricants on O-rings or valve seals. Use only 100% silicone lubricants.
 - Hydrocarbons such as kerosene, benzene, gasoline, etc may damage products that contain o-rings or plastic components. Exposure to such hydrocarbons may cause the products to leak. Do not use the product(s) contained in this document on water supplies that contain hydrocarbons such as kerosene, benzene, gasoline, etc.
- Use only the power transformer supplied with this water conditioning system.
- All electrical connections must be completed according to local codes.
- The power outlet must be grounded.
- For installations where plastic plumbing is used, install an appropriate grounding strap across the inlet and outlet piping of the building's metal plumbing to ensure that a proper ground is maintained.
- To disconnect power, unplug the AC adapter from its power source.
- Observe drain line requirements.
- Support the full weight of the plumbing system with pipe hangers or other means.
- Do not allow this water conditioning system to freeze. Damage from freezing will void this water conditioning system's warranty.
- It is established that when daytime water pressure exceeds 80psi (5.5 bar), the maximum pressure rating of 125psi (8.6 bar) can be exceeded. A pressure regulator must be installed on this system or warranty is voided.
- Periodic cleaning and maintenance is required for system to function properly.
- Observe all warnings that appear in this manual.
- Keep the media tank in the upright position. Do not turn upside down or drop. Turning the tank upside down or laying the tank on its side can cause media to enter the valve.
- Use only regenerants designed for water conditioning. Do not use ice melting salt, block salt or rock salt.

How To Use This Manual

This installation manual is designed to guide the installer through the process of installing and starting up this commercial water conditioning systems.

This manual is a reference and will not include every system installation situation. The person installing this equipment should have:

- Training on the control valve.
- Knowledge of water conditioning and how to determine proper control settings.
- Adequate plumbing skills.

* Vaseline® is a registered trademark of Unilever.

⚠ WARNING

Do not use with water that is microbiologically unsafe or of unknown quality without adequate disinfection before or after the system.

Table of Contents	Page
Safety Information	3
How To Use This Manual	3
Introduction	4
Project Data Sheet	5
System Specifications	6-7
Set Up	8
Operating Parameters	8
System Installation	9-10
Start Up Instructions	10
Installation Diagrams	11-12
Controller Electrical Connections	13
Controller Programming and Operation	14
Button Operation and Functions	14
Regeneration and Error Screens	14
User Displays	15
Configuration Settings	16-19
OEM Softener System Setup	20-22
Setting Option Table	23
Installer Display Settings - Regeneration Type Auto	24
Installer Display Settings - 7 Day Regeneration	25
Diagnostics	26-27
Replacing the Media	28
Replacement Parts - Major System Components	29-30
Replacement Parts - CWS-150 Control Valve Body	31
Replacement Parts - CWS-150 Regenerate Components	32
Replacement Parts- 1 1/2" Stainless Electronic Turbine Meter Assembly	33
Troubleshooting	34-37
Water Softener Flow Diagrams	38-40
Injector Flow Data and Draw Rates	41-43
Injector Nozzle and Throat Chart	44
Motorized Alternating Valve Piston Style Applications	45-47
Warranty	48

Introduction

Principals of Softening- Ion Exchange

In nature, water acts as a solvent that dissolves substances it comes in contact with such as solid rock. When water dissolves limestone rock, which is composed of calcium and magnesium, the solid calcium and magnesium become ions. This means they have been dissolved into the water and are now a liquid. An ion with a positive electrical charge is called a cation. Calcium and magnesium hardness ions in water are positively charged cations. When water dissolves enough calcium and magnesium hardness cations it is classified as hard water, which can cause lime scale build up in plumbing systems, water spots, and an increase in soap and cleaning product usage.

Ion exchange water softening is a process where an ion exchange resin is used to effectively exchange calcium and magnesium hardness cations for sodium cations in the water.

New, or freshly regenerated, ion exchange resin is saturated with sodium cations. As calcium and magnesium hardness cations come in contact with the ion exchange resin, they attach to the resin and sodium cations are released into the water. This is possible because the hardness cation are more attracted to the ion exchange resin than the sodium cations. Therefore, scale forming calcium and magnesium cations have been exchanged for non-scale forming sodium cations as the water is treated. If the calcium and magnesium content of the water is reduced to less than 17.1 mg/L, that water is classified as soft water.

Eventually the ion exchange resin will become exhausted, depleted of sodium, and will need to be regenerated with a sodium brine solution to restore its capacity to soften water. This system includes a flow meter to track treated water volume and initiate the regeneration process before resin exhaustion occurs.

Regeneration occurs automatically and consists of 5 steps:

Step 1- Backwash

Approximate Duration 10 Minutes- Fresh water flow is directed upward through the resin bed, to remove solid particles the resin bed has captured, sending them to drain.

Step 2- Brine Draw

Approximate Duration 15-20 Minutes- Brine water is drawn from the brine tank, rinsed over the ion exchange resin, driving away the calcium and magnesium cations and restoring sodium cations within the resin. Calcium and magnesium is sent to drain.

Step 3- Slow Rinse

Approximate Duration 40-45 Minutes- Once the brine tank is emptied of brine water, fresh water will continue to rinse over the resin and rinse calcium and magnesium cations to drain.

Step 4- Second Backwash (Optional)

Approximate Duration 8 Minutes- Fresh water flow is directed upward through the resin bed to mix the resin directly after slow-rinse.

Step 5- Rapid Rinse

Approximate Duration 10 Minutes- After the conclusion of slow rinse, fresh water will rinse over the resin to ensure any residual sodium brine has been cleaned from the resin before it returns to service.

At the conclusion of Rapid Rinse:

Simplex single tank systems return to the "In Service" position. Multi tank systems remain in the "Stand By" position.

Step 6- Brine Tank Refill

Approximate Duration User Adjustable- In this final step of regeneration, water is added back into the brine tank so that a brine solution can be prepared for the next regeneration.

Project Data Sheet

Installation Summary

Installation Date: _____

Installation Location: _____

Installer(s): _____

Phone Number: _____

Application Type: (Softener) _____ Other: _____

Water Source: _____

Water Test Results: _____

Hardness: _____ Iron: _____ pH: _____

Other: _____

Misc:

Service Flow Rates: min. _____ max. _____

Tank Size: Diameter _____ Height: _____

Resin or Media Volume: _____

Resin or Media Type: _____

Capacity: _____

Salt or Fill Setting per Regeneration: _____

Brine Tank Size: _____

Control Valve Configuration:

Valve Type: _____

Valve Part Number: _____

Valve Serial Number: _____

Regenerant Refill Control: _____ gpm/lpm

Injector Size: _____

Drain Line Flow Control: _____ gpm/lpm

System Specifications

Dimensions - Weights

CWS-150

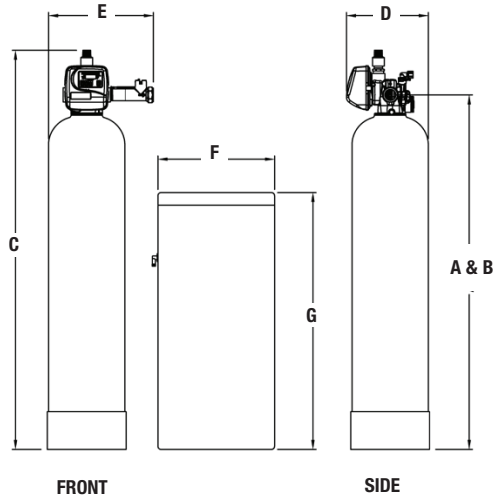

CWSTA-150

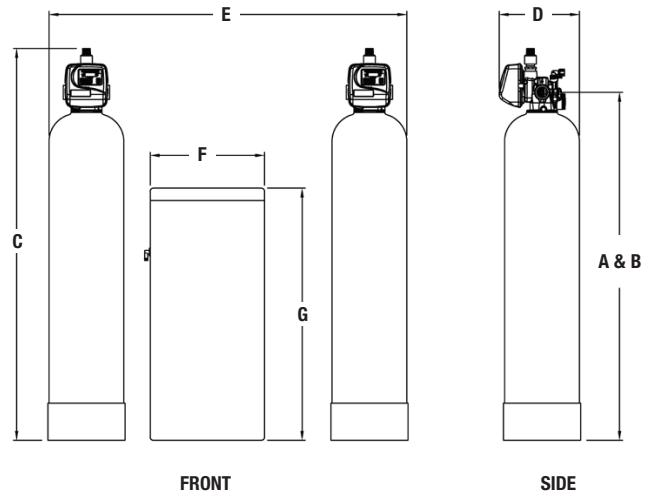

Series CWS-150

MODEL NO.	DIMENSIONS												WEIGHTS			
	A		B		C		D		E		F		G		lb	kg
	in.	mm	in.	mm	in.	mm	in.	mm	in.	mm	in.	mm	in.	mm		
M4410W	53 ¹ / ₄	1353	53 ¹ / ₄	1353	61	1550	12	305	16 ³ / ₄	425	18	457	40	1016	210	95
M4414W	68 ¹ / ₄	1734	68 ¹ / ₄	1734	73 ⁵ / ₈	1869	14	356	17 ³ / ₄	451	18	457	40	1016	240	109
M4418W	68 ¹ / ₄	1734	68 ¹ / ₄	1734	73 ⁵ / ₈	1869	16	406	18 ³ / ₄	476	18	457	40	1016	320	145
M4422W	68 ¹ / ₄	1734	68 ¹ / ₄	1734	73 ⁵ / ₈	1869	18	457	20 ³ / ₄	527	24	607	41	1041	380	172
M4426W	65 ¹ / ₄	1657	65 ¹ / ₄	1657	70 ⁵ / ₈	1793	21	533	21 ¹ / ₄	540	24	607	41	1041	585	265
M4430W	75 ¹ / ₄	1911	75 ¹ / ₄	1911	80 ⁵ / ₈	2047	24	610	24 ¹ / ₄	616	30	762	50	1270	710	322

Series CWSTA-150

MODEL NO.	DIMENSIONS												WEIGHTS			
	A		B		C		D		E		F		G		lb	kg
	in.	mm	in.	mm	in.	mm	in.	mm	in.	mm	in.	mm	in.	mm		
M4410WTA	53 ¹ / ₄	1353	53 ¹ / ₄	1353	61	1550	12	305	52	1320	18	457	40	1016	420	190
M4414WTA	68 ¹ / ₄	1734	68 ¹ / ₄	1734	73 ⁵ / ₈	1869	14	356	60	1524	18	457	40	1016	480	218
M4418WTA	68 ¹ / ₄	1734	68 ¹ / ₄	1734	73 ⁵ / ₈	1869	16	406	60	1524	18	457	40	1016	640	290
M4422WTA	68 ¹ / ₄	1734	68 ¹ / ₄	1734	73 ⁵ / ₈	1869	18	457	70	1778	24	607	41	1041	760	345
M4426WTA	65 ¹ / ₄	1657	65 ¹ / ₄	1657	70 ⁵ / ₈	1793	21	533	75	1905	24	607	41	1041	1170	531
M4430WTA	75 ¹ / ₄	1911	75 ¹ / ₄	1911	80 ⁵ / ₈	2047	24	610	87	2210	30	762	50	1270	1420	644

Specifications

MODEL NO.	TANK SIZE	MINERAL TANK		GRAVEL	BRINE TANK		SOFTENING CAPACITY		LBS. SALT PER REGENERATION		FLOW RATE & PRESSURE			
		RESIN Ft ³			TANK SIZE	SALT FILL	MAX	MIN	MAX	MIN	SERV GPM	DROP PSI	BKW GPM	
M4410W	12" x 52"	3		30 lbs.	18" x 40"	400		60 K	40 K	30	12	25/40	15/25	4
M4414W	14" x 65"	3		60 lbs.	18" x 40"	400		90 K	60 K	45	18	35/55	15/25	5
M4418W	16" x 65"	4		80 lbs.	18" x 40"	400		120 K	80 K	60	24	57/65	15/25	7
M4422W	18" x 65"	5		100 lbs.	24" x 41"	600		150 K	100 K	75	30	60/77	15/25	11
M4426W	21" x 62"	7		100 lbs.	24" x 41"	800		210 K	140 K	105	42	74/97	15/25	13
M4430W	24" x 72"	10		200 lbs.	30" x 50"	1400		300 K	200 K	150	60	80/100	15/25	15

NOTICE

Capacities are based on resin manufacturer's data and are dependent upon influent water TDS, temperature, bed depth, and flow rates. Feed water must be free of oil and color. Pipe size, tank size, and space requirements are in inches. Capacities and flow rates expressed above are per tank. Flow rates listed at 25psi drops are for intermittent peak flow rates and are not to be used as continuous flows.

NOTICE

Flow rates listed above are based on pressure drop only. Selecting a system based on pressure drop alone does not guarantee that the system will provide adequately softened water. System selection should be based on resin quantity, capacity required, feed water analysis, and application requirements.

Ordering Information

Ordering Information for 1-1/2" Simplex (CWS-150) and Duplex Alternating (CWSTA-150) Softeners

MODEL NO.	ORDERING CODES	DESCRIPTION	SPACE REQUIRED D X W X H	WEIGHT LBS
M4410W	68105557	2 Cubic Foot 1-1/2" Simplex Softener with Flow Meter	24" x 44" x 75"	210
M4414W	68105558	3 Cubic Foot 1-1/2" Simplex Softener with Flow Meter	24" x 44" x 75"	240
M4418W	68105559	4 Cubic Foot 1-1/2" Simplex Softener with Flow Meter	24" x 44" x 75"	320
M4422W	68105560	5 Cubic Foot 1-1/2" Simplex Softener with Flow Meter	24" x 50" x 87"	380
M4426W	68105561	7 Cubic Foot 1-1/2" Simplex Softener with Flow Meter	24" x 52" x 84"	585
M4430W	68105562	10 Cubic Foot 1-1/2" Simplex Softener with Flow Meter	39" x 69" x 96"	710
M4410WTA	68109948	2 Cubic Foot 1-1/2" Duplex Alternating Softener with Flow Meter	24" x 64" x 75"	420
M4414WTA	68109949	3 Cubic Foot 1-1/2" Duplex Alternating Softener with Flow Meter	24" x 64" x 75"	480
M4418WTA	68109950	4 Cubic Foot 1-1/2" Duplex Alternating Softener with Flow Meter	24" x 64" x 75"	640
M4422WTA	68109951	5 Cubic Foot 1-1/2" Duplex Alternating Softener with Flow Meter	24" x 68" x 89"	760
M4426WTA	68109952	7 Cubic Foot 1-1/2" Duplex Alternating Softener with Flow Meter	24" x 72" x 84"	1170
M4430WTA	68109953	10 Cubic Foot 1-1/2" Duplex Alternating Softener with Flow Meter	39" x 89" x 96"	1420

Set Up

Unpack system and make sure all components are accounted for according to the diagram below according to your specific series number. If any components are missing or damaged contact your Watts representative. If they can not be reached contact Watts customer service at 1-800-659-8400.

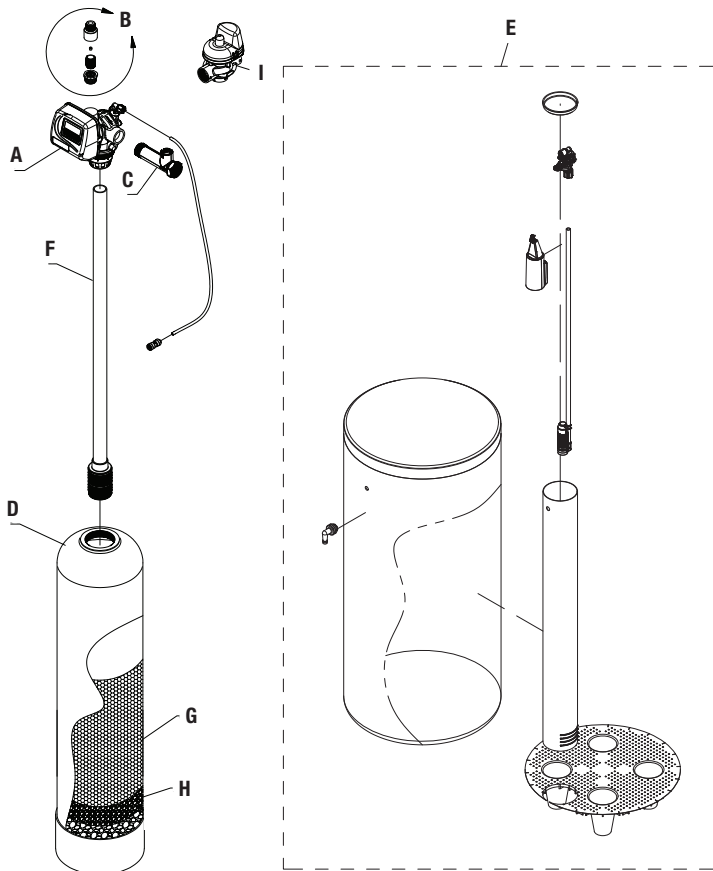

* Duplex Alternating Systems Only

Operating Parameters

pH	6 to 10
Hardness (maximum)	Depends on customer's acceptable hardness leakage level
Water Pressure	25psi to 125psi (171 kPa to 8.6 bar)
Temperature	40 - 110°F (4 - 43°C)
Free Chlorine (maximum)	1 mg/L
Iron (maximum)	1 mg/L
Oil and H ₂ S	None Allowed
Turbidity	Less than 5.0 NTU
Total Dissolved Solids	Must be below 750mg/L for the softener to produce less than 1 grain per gallon soft water
Minimum Ambient Temperature	40 - 110°F (4 - 43°C)
Maximum Ambient Temperature	120°F/52°C
Maximum Humidity	75%
Power Supply Input Voltage	100-120 VAC
Power Supply Input Frequency	50/60 Hz
Power Supply Output Voltage	15 VDC
Power Supply Output Current	500 mA (per control valve)
Maximum Altitude	2,000 meters above sea level
Water known to have heavy loads of dirt and debris may require pre-filtration prior to the water softening system.	
For all other guideline information please contact your Watts representative.	

COMPONENT LABEL	COMPONENT	QUANTITY OF MAJOR COMPONENTS	
		CWS-150 SIMPLEX	CWSTA-150 DUPLEX ALTERNATING
A	Number of Control Valves	1	2
B	Number of Drain Line Flow Controllers*	1	2
C	Number of Flow Meters	1	1
D	Number of Mineral Tanks	1	2
E	Number of Brine Tanks	1	1
F	Number of Distributor Tubes*	1	1
G	Resin**	Quantity Varies Depending On System Size	Quantity Varies Depending On System Size
H	Gravel**	Quantity Varies Depending On System Size	Quantity Varies Depending On System Size
I	MAV Valve	0	1

* Drain line flow controllers may come factory assembled on control valve's drain port depending on size. Distributor tubes ship inside mineral tanks.

** Water softening systems that use mineral tanks larger than 12" in diameter are not factory loaded with resin and gravel. For unloaded systems, the media is in bags and ship on the system pallet. The proper amount of media is supplied for the mineral tank used.

System Installation

Pre-Installation Considerations

- A minimum of 25psi of water pressure is required for regeneration valve to operate effectively.
- A continuous 115 volt, 60 Hertz current supply is required. Make certain the current supply is always hot and cannot be turned off with another switch.
- Condition of existing plumbing should be free from lime and iron buildup. Piping that is built up heavily with lime and/or iron should be replaced. If piping is clogged with iron, a separate iron filter unit should be installed ahead of the water softener.
- The softener should be located close to a drain.
- Always provide for the installation of a bypass valve.
- The full weight of the plumbing system must be supported by pipe hangers or other means.
- Do not install the system where it would block access to the water heater, main water shutoff, water meter, or electrical panels.
- Install the system in a place where water damage is least likely to occur if a leak develops.
- If applicable, use di-electric unions where dissimilar metals are present.

NOTICE

The main control valve and all plumbing connections have right-hand threads. Turn clockwise to install.

NOTICE

If O-ring lubricant is required, only use a silicone based compound formulated for potable water O-ring applications. Watts recommends Ordering Code #68102757 Silicone Lubricant. The use of other types of lubricants may attack the control's plastic or rubber components. Petroleum-based lubricants can cause swelling in rubber parts, including O-rings and seals.

⚠ WARNING

Do not exceed water pressure of 125psi (8.6 bar). Do not exceed 110°F (43°C). Do not subject unit to freezing conditions.

General Installation Instructions

NOTICE

Installation diagrams and additional details are available on pages 11-14 of this manual.

1. Turn off water heater(s).
2. Turn off the main water supply to the building and open a treated water faucet (cold and hot) to relieve any pressure within the plumbing system.
3. Place the mineral tank(s) into its final position for installation. CWSTA-150 series systems require innerconnection with a 8' innerconnecting cable. Do not place mineral tanks farther apart than 6' center to center. Make sure that the location is level and sturdy enough to support the weight of the system once it is in operation.
4. Unloaded mineral tank(s) will need to be loaded with resin and gravel media following the instructions below:
 - 4a. Inspect the distributor screen for damage, and make sure the screen is present before loading the mineral tank with media. Before proceeding with installation, replace any damaged components immediately.
 - 4b. Cap the top open end of the distributor tube with tape and plastic sheeting to keep all media and foreign debris from entering the distributor tube. This cap must be secure and not come off during media loading.
 - 4c. Place the distributor tube, screen end down, into the mineral tank and center it in the bottom. The top of the distributor tube should be flush with the top of the tank. Test the tape cap to make sure it can not come off during the media loading process.
 - 4d. Make sure the plastic and tape cap is secure to the top of the distributor tube, place a funnel on the top of the tank and load first the gravel (if different sizes of gravel are used load the largest gravel first, then the smaller gravel) then the softening resin into the tank. The cap must not come off of the distributor tube during the loading of the media.
 - 4e. Remove the funnel from the top of the tank and plastic cap and tape from the top of the distributor tube. **DO NOT PULL UP ON THE DISTRIBUTOR TUBE** when removing the cap. The distributor tube top must remain flush with the top of the tank.
 - 4f. Clean any media from the threads and top of the mineral tank. Media in the threads and on the O-ring sealing surface of the tank can cause tank thread damage and prevent the control valve's O-ring seal from sealing properly.
 - 4g. Lubricate the O-rings on the bottom of the control valve (distributor tube port O-ring and top of tank O-ring). Use nonpetroleum based silicone lubricant only.
 - 4h. Press the upper diffuser into the base of the control valve until it is fully engaged, then place the control valve on top of the tank. When performing this step, seat the top of the distributor tube inside the distributor port located on the bottom of the control valve first, then press the control valve down until the control valve threads come in contact with the tank threads. This ensures that the distributor tube is properly seated into the bottom of the control valve.
 - 4i. Tighten the control valve onto the tank with a clockwise rotation. Be careful not to cross thread the control valve to tank connection or over tighten it. A hand tight fit is appropriate for the control valve torque. **DO NOT** use a wrench. Tank or control valve damage could result. **DO NOT** apply thread sealant or plumbing tape on the control valve to tank threaded connection.
- 5*. Install flow meter. For CWS-150 Simplex systems, apply a suitable thread sealant to the male threads of the meter and with the meter's direction of flow arrow pointing in the direction of water flow, install the meter directly into the outlet port of the system's control valve. For CWSTA-150 Series Duplex Alternating systems, apply a suitable thread sealant and install the meter in the common outlet water line of the two control valves within 30" of the nearest control valve's controller. The meter's direction of flow arrow must point in the direction of water flow.
- 6*. Rotate meter clockwise to tighten, by gripping the meter on the hex end outlet with a wrench, and continue to tighten the flow meter end connector until tight. Tighten the meter until the meter cable connection port is facing upwards.

System Installation

- 7*. Connect the cold water supply to the inlet port of the water softening system's control valve(s). When constructing the supply line, install an inlet water isolation valve(s) and plumbing union fitting(s) (user supplied) in the supply line of the control valve(s) and close the isolation valve(s). The union fitting(s) should be located between the isolation valve(s) and the system's inlet port(s).
- 8*. Install an inlet water sample port in the supply line and close it.
- 9*. If risk of vacuum exists, install Watts # 0556031 vacuum relief valve in the supply line to protect the system against vacuum damage.
- 10*. For CWS-150 series systems, connect the outlet water connection of the water meter to the water line requiring softened water. When constructing this outlet water line, install an outlet water isolation valve and plumbing union fitting (user supplied) in the outlet line and close the isolation valve. The union fitting should be located between the outlet of the control valve and the outlet isolation valve. For CWSTA-150 series systems connect the outlet water connection from the softener on the left to the "A" port of the motorized alternating valve (MAV). Connect the outlet of the water softener on the right to the "B" port of the MAV. The "C" port of the MAV is the common outlet water line that the meter will be installed in and will connect to the water line requiring softened water. When constructing these outlet water lines, install outlet water isolation valves and plumbing union fittings (user supplied) in the outlet lines and close the isolation valves. The union fittings should be located between the outlet of the control valves and the outlet isolation valves.
- 11*. Install an outlet water sample port on the outlet water line of the system and close it.
- 12*. Install a bypass valve between the inlet and outlet plumbing water lines and close it.
- 13*. If not already factory installed on the control valve(s), attach the drain line flow controller(s) directly to the control valve's drain port(s). See page 11 for Drain and Brine Connection Detail. The flow arrow on the drain line flow controller(s) must point towards the drain receptacle. Only plumbing tape is allowed on the drain line flow controller fitting threads.

⚠ WARNING

Operating a system without a drain line flow controller will cause all media to flow out of the system through the drain line.

- 14*. Construct the drain line routing it to an appropriate drain receptacle abiding by all local building and plumbing codes. DO NOT construct drain line to elevations that exceed 4 feet above the drain port of the control valve, or reduce the drain line diameter to smaller than that of the drain line flow controller. Install a plumbing union fitting in the drain line close to the drain line flow controller. The drain line must be anchored to the floor.
- 15*. Connect the brine tank to the water softener's control valve brine port using the factory supplied fittings and tubing. See page 11 for Drain and Brine Connection Detail. The brine tank should set on a common elevation as the mineral tank and within distance so that it can be reached by the length of factory supplied brine tubing. For CWSTA-150 series systems, use the factory provided TEE fitting so both control valves connect to a common brine tank. Add enough water (6") to the brine tank so that water covers the top of the air check. DO NOT add salt to the brine tank at this time.
16. Connect the meter cable to the control valve. For CWS-150 series systems connect the meter cable to the control valve controller's meter connection port. For CWSTA-150 series systems connect the meter to control valve of the right hand softener.

17. For CWSTA-150 series systems, connect the innerconnecting cable between the 2 control valves routing the cable through the back plate of the control valves. Then connect MAV cable to the left hand water softener control valve controller. See Figure on page 13 for wiring diagram.
18. If applicable, install a metal bonding strap across metal inlet and outlet plumbing lines to maintain electrical continuity.
19. Plug in the 15V power supply transformer(s) into a 115V 60Hz power outlet and program the system according to the System Type and application requirements following the Control Valve Programming section of this manual.

The system is now ready for Start Up.

Start Up Instructions

1. Ensure all inlet and outlet isolation valves and the bypass valves are in the closed position and the treated water faucet hot and cold side are in the open position.
2. Open the main water supply valve to the building.
3. Check for leaks and repair as needed.
4. Press and hold Regen button for >3 sec to manually start the regen cycle, place the system into the backwash position. Once the system cycles into the backwash position, unplug the control valve from the power outlet to keep the system in the backwash position.
5. Open the inlet isolation valve slightly until water can be heard flowing through the isolation valve and allow the mineral tank to fill with water. Air will come out of the drain line until the mineral tank is full of water. Once water flow at the drain line is observed, fully open the inlet valve and allow water flow to drain for 10 minutes to flush the resin bed of any color. If water at the drain shows any discoloration, continue to flush the resin bed until water at the drain is clear.
6. After resin bed flushing is complete, plug the system back into the power outlet and return the control valve to the service position by advancing through each step of regeneration by pressing the regen button. See Manually Initiating a Regeneration on page 14 of this manual. If this is a CWSTA-150 system perform steps 4-6 on the other tank.
7. Program the system according to the System Type following the Control Valve Programming section of this manual.
8. Put the appropriate amount of water in the brine tank. This is accomplished by manually cycling the control valve to cycle step 5 "Fill" and allowing a complete brine tank refill cycle to conclude.
9. Put the appropriate amount of salt in the brine tank. Do Not fill the salt level past the brine well lid.
10. Fully open the outlet isolation valve(s).
11. Ensure the bypass valve is in the closed position.
12. Check for leaks and repair as needed.
13. Allow water to flow from the hot and cold side treated faucet until all air has been purged from the plumbing system. Then close both the hot and cold side treated water faucet.
14. Turn on water heaters.
Start up is now complete and the system is ready for operation.

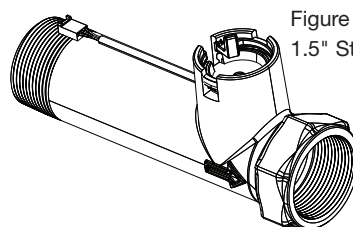

Figure 1
1.5" Stainless Steel Meter

Installation Diagrams - CWS-150 Simplex Systems

Installation Reference Notes For All System Installation Drawings:

1. All dimensions are on page 6 of this manual & unless otherwise noted are ± 1 inch (25mm).
2. All items shown in phantom line are to be provided by others.
3. All dimensions are subject to change without any notice.
4. Install unions fittings on inlet, outlet & drain plumbing connections.
5. Provide a 2 feet minimum clearance above mineral tank for filling media.
6. A GFCI equipt electrical outlet should be provided within 5 feet of equipment location.
7. Use dielectric unions on plumbing connections of control valve when dissimilar metals are present.
8. Provided system shall not be subject to any vacuum. If risk of vacuum is present, install siphon break on drain line & install vacuum relief valve Watts ordering code # 0556031 on inlet line.
9. Brine tank dimensions shown on table are factory selected for use with the specified system size.
10. Do not install drain line directly to a drain. For proper drain connection follow all national, state and local codes. Do not construct drain line to elevations that exceed 4 feet above the control valve's drain port.
11. The full weight of the piping and valves must be supported by pipe hangers or other means.
12. Inlet and outlet headers need to be sized according to flow rate requirements by others.
13. Power requirements: 115v/60hz 500mA per control valve unless otherwise specified.
14. Brine tank must be located within 10 feet of system control valve and on a common floor elevation with mineral tank to ensure proper brine draw operation.
15. Use factory supplied brine tubing. Do not use smaller diameter tubing than what is supplied.
16. Limit inlet pressure to not exceed maximum published operating pressure.

CWS-150 SIMPLEX

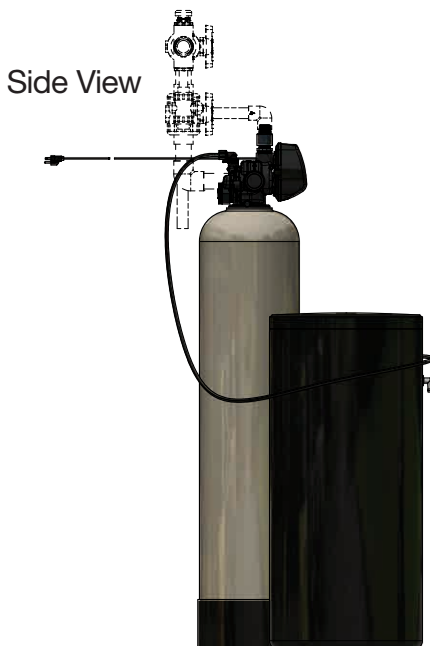
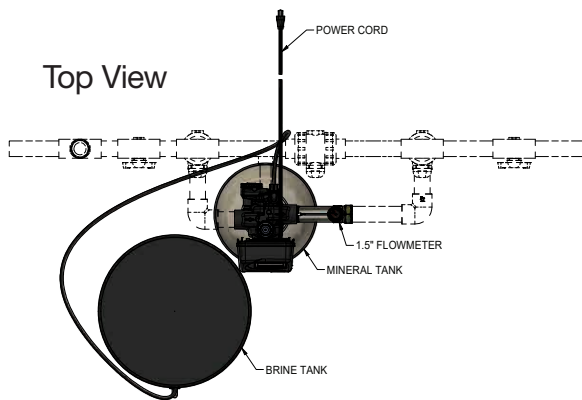

Drain and Brine Connection Detail

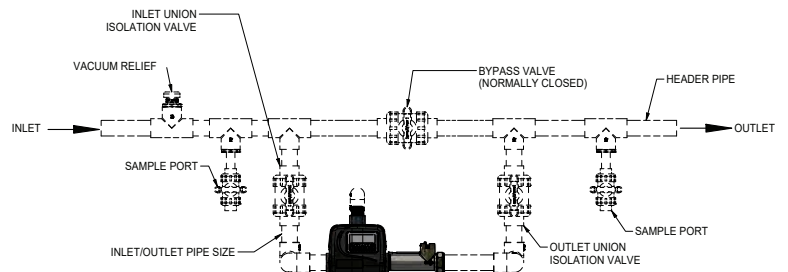
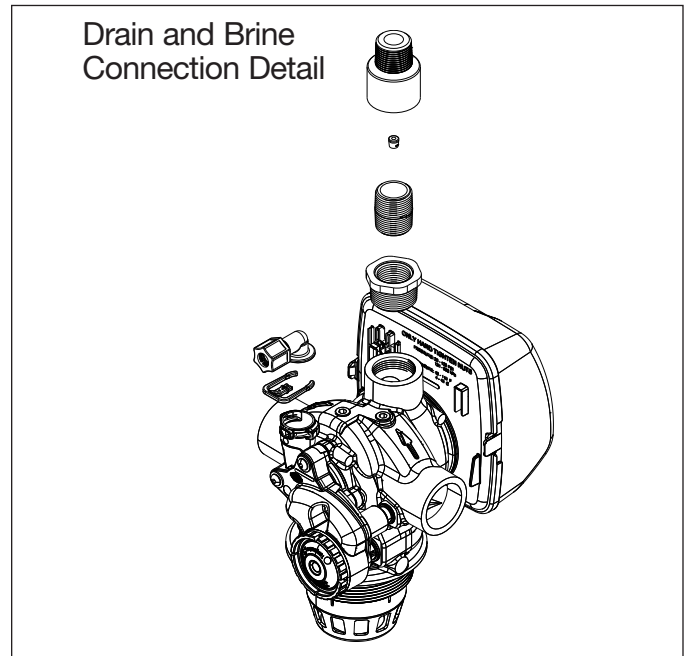

Front View



CWSTA-150 TWIN ALT
Diagram on next page

Installation Diagrams - CWSTA-150 Duplex Alternating Systems

CWSTA-150 TWIN ALT

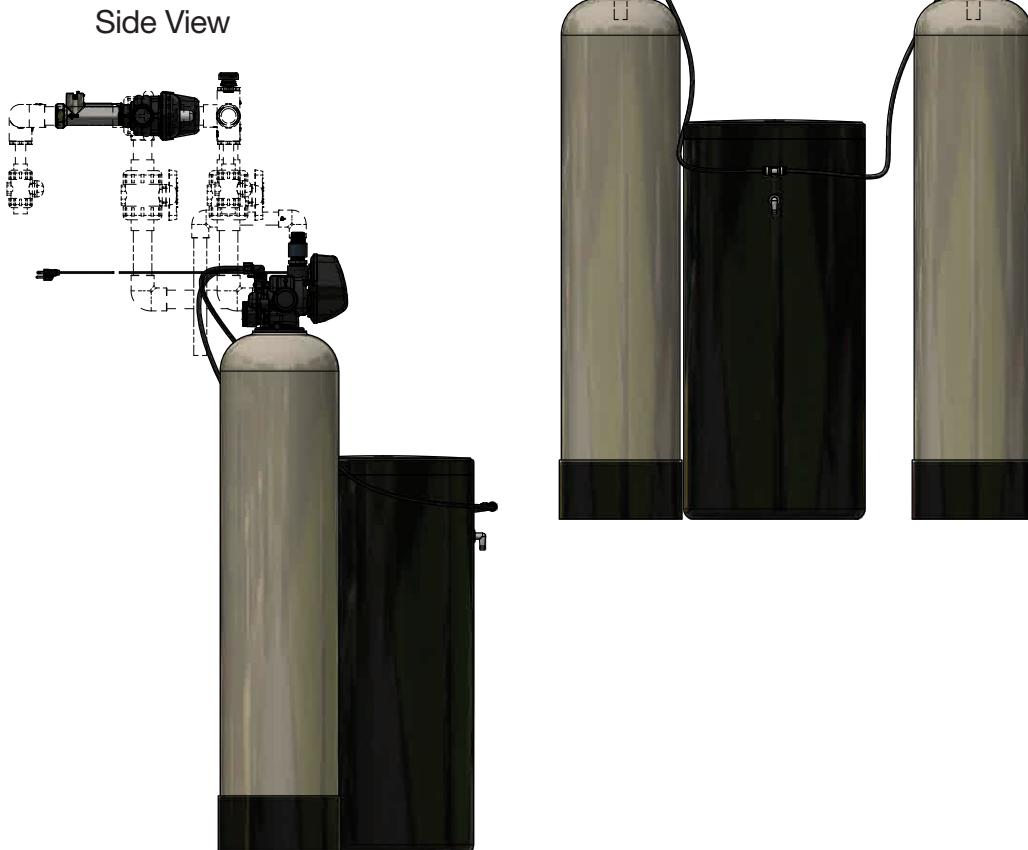
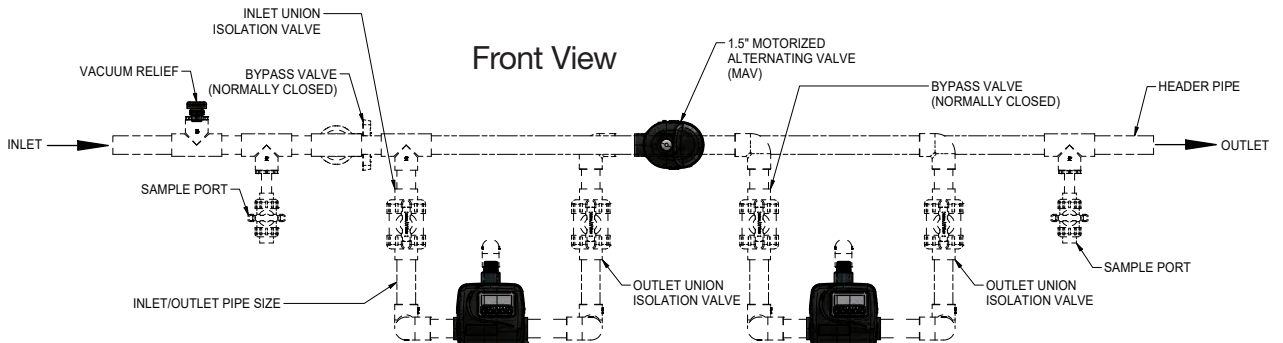
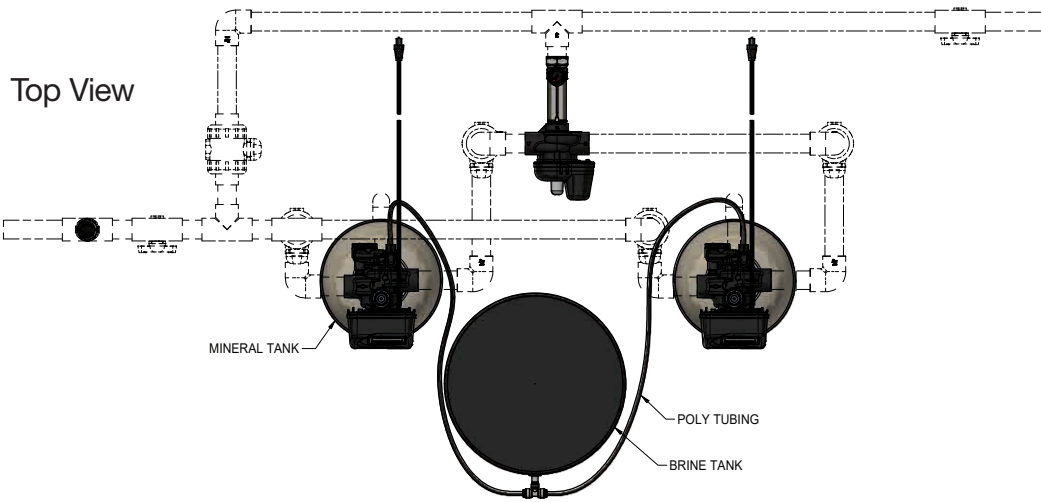

Controller Electrical Connections

Electrical Connections:

NOTICE Power supply and drive motor cables include cable harnesses that are already connected to the control board.

If these cable need to be disconnected from the control board, pull on the white connectors while rocking side to side. DO NOT pull on the wires. To reconnect, push the white cable connectors firmly into position on to the control board until they are fully mated.

See Controller Electrical Connection Diagram below for additional information.

CWS-150 FRONT COVER AND DRIVE ASSEMBLY			
DRAWING NO.	LEGACY NO.	DESCRIPTION	QUANTITY
1	V3175EE-01	FRONT COVER ASSEMBLY	1
2	V3107-01	MOTOR	1
3	V3002-A	DRIVE BRACKET ASY	1
4	V3408EE-04BOARD	THRU/2 EE PCB 5 DIGIT REPL	1
5	V3110	DRIVE GEAR 12X36	3
6	V3109	DRIVE GEAR COVER	1
Not Shown	V3186-06	POWER SUPPLY US 15VDC HOCP	1
	V3186-01	POWER CORD ONLY	
Not Shown	V3178	DRIVE BACK PLATE	1

Refer to Control Valve Service Manual for other drawings and part numbers.

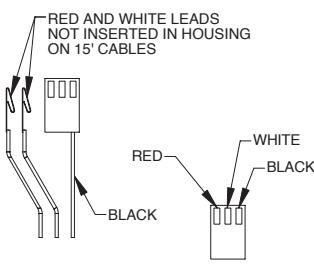
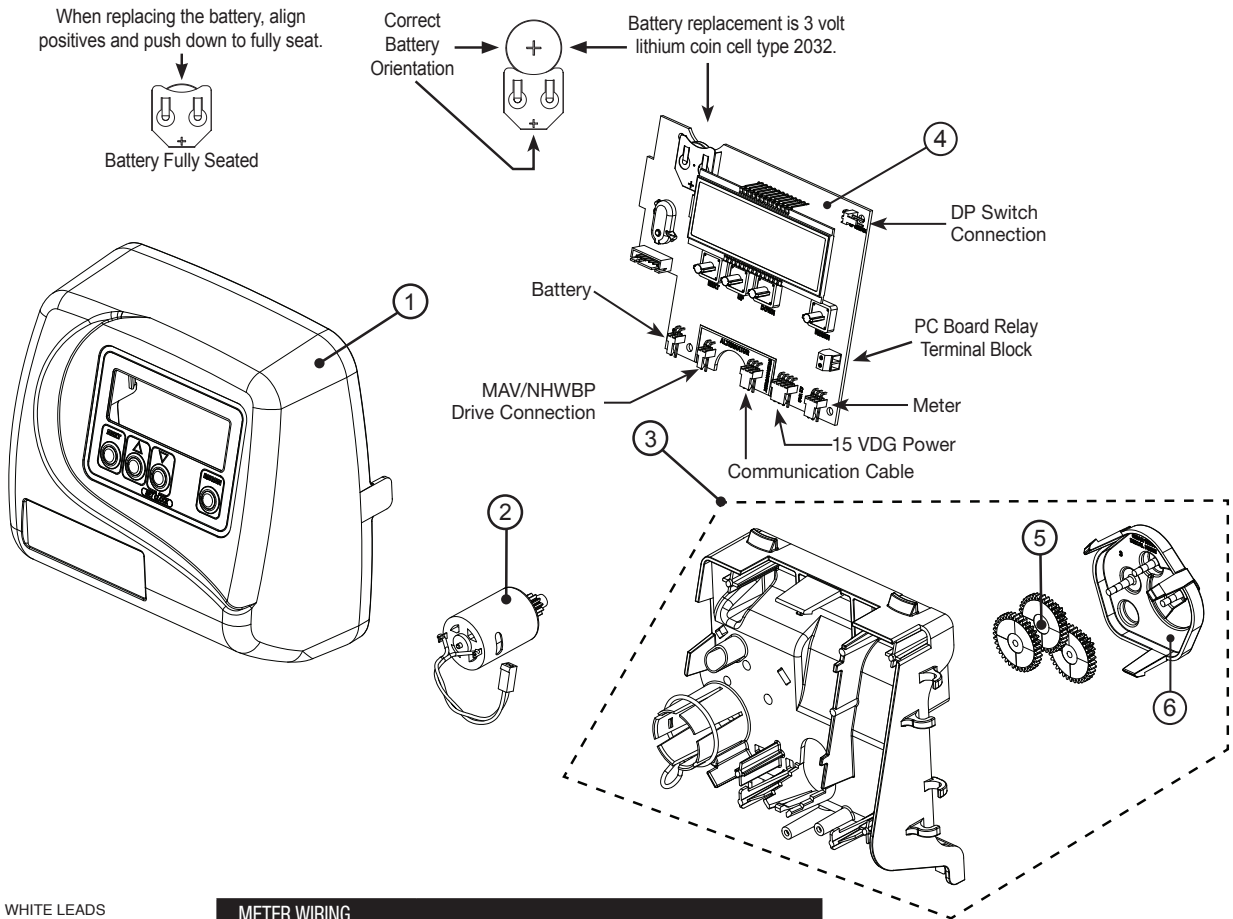

METER WIRING	
Wire Gauge:	22
Red:	Positive
Black:	Negative
White:	Signal (Meter Output)
Voltage Requirement:	4 – 24 VDC
Output Signal:	0.4 Hz – 47.5 Hz
Terminals:	Molex 41572 or 40445
Housing:	Molex 22-01-3037 (Series 2695 White Housing)

Controller Programming and Operation

Button Operation and Function

NEXT

Scrolls to the next display

REGEN

Pressing once and releasing will schedule a regeneration at the preset delayed regeneration time.

Pressing again and releasing will cancel the regeneration.

Pressing and holding for 3 seconds will initiate an immediate regeneration

Pressing while in regeneration will advance to the next cycle.

Pressing in the program levels will go backwards to the previous screen



Changes variable being displayed

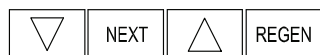

Key sequence to lock and unlock program settings



Holding for 3 seconds initiates a control reset. The software version is displayed and the piston returns to the home/service position, resynchronizing the valve.



Used with valve type. 1.0 F holding for at least 3 seconds causes a switch in the tank in Service without cycling the regeneration valve. After tank switch, days remaining and capacity remaining status is retained for each tank until the next regeneration.

Regeneration and Error Screens



Regen Screen

Displays the time remaining in the current cycle. Pressing REGEN advances to the next cycle.



Error Screen

Alternated flashing Err and error code every 3 seconds. Clear by disconnecting the power supply at the PC board and reconnecting, or press NEXT and REGEN simultaneously for 3 seconds.



In Alternator Systems when a unit is waiting to initiate the first cycle step of regeneration, "REGEN Pndg" is displayed.

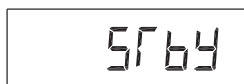

"STbY" is displayed in Alternator Systems when a valve is in Standby state.



"REGEN Pndg RINSE FILL" is displayed whenever a zero-capacity tank has transferred to an off-line state and is currently waiting to initiate the second portion of regeneration cycle. Viewed only when Delayed Rinse and Fill is set to ON.

Regeneration Cycles and Times

Cycle	Range		
	Softening	Filtering Regen	Filtering Backwash
Backwash	1-120 minutes	1-120 minutes	1-120 minutes
Regenerant Draw/Slow Rinse (UP or DN)	1-180 minutes	1-180 minutes	NA
Fast Rinse	1-120 minutes	1-120 minutes	1-120 minutes
Regenerant Refill	0.1- 200.0 lbs.	1-99.0 GAL	NA
Regenerant Refill 2.0 or 1.5 set to MIN (softening only)	0.1-99.0 minutes	0.1-99.0 minutes	NA
Service	1-480 minutes	NA	NA

If 1.5 or 2.0 is selected in Step 2CS, cycles can be set to "oFF".

The user can initiate manual regeneration. The user has the option to request the manual regeneration at the delayed regeneration time or to have the regeneration occur immediately.

1. Pressing and releasing the REGEN button. "REGEN TODAY" will flash on the display and the regeneration will occur at the delayed regeneration time. The user can cancel this request, except by resetting the control by pressing NEXT and REGEN simultaneously for 3 seconds.
2. Pressing and holding the REGEN button for approximately 3 seconds will immediately start the regeneration. The user cannot cancel this request, except by resetting the control by pressing NEXT and REGEN simultaneously for 3 seconds.

Controller Programming and Operation

User Displays

When the system operating, one of five displays may be shown. Pressing NEXT will alternate between the displays shown below.

General Operation

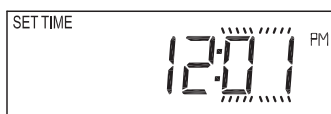

User 1

Typical user display. Shows volume remaining to regeneration. This screen will not be viewed if the control is set for time-clock operation.

User 2

Displays number of days to next regeneration.

User 3

Flow Rate.

Displays present flow rate.

Not viewed (along with SOFTENING or FILTERING Icon) if ALT A or ALT b is set in CONFIGURATION 4 and the valve is currently in Standby. When 1.0 Γ is set in CONFIGURATION 1, the display will indicate the tank currently in Service ("A" or "b") in the leftmost digit.

User 4

Displays total volume in gallons since last reset. If a meter is not used this display will be shown but 0 will be displayed.

PRESS ▼ FOR 3 SECONDS TO RESET TO 0.

User 5

Shows current time.

Setting Time of Day

Push NEXT until time of day screen is displayed. Press and hold ▼ until SET TIME is displayed and the hour flashed once. Press ▲ or ▼ until the correct hour is displayed.

Then press NEXT. The minutes will flash. Press ▲ or ▼ until the correct minute is displayed.

Press NEXT to return to the User Displays. Time of day should only need to be set after power outages lasting more than 8 hours. If the battery has been depleted and a power outage occurs, or when daylight saving time begins or ends. If a power outage lasting more than 8 hours occurs, the time of day will flash on and off which indicated the time of day should be reset. If a power outage lasts less than 8 hours and the time of day flashes on and off, the time of day should be reset and the battery replaced.

Controller Programming and Operation

Configuration Settings

Step 1CS

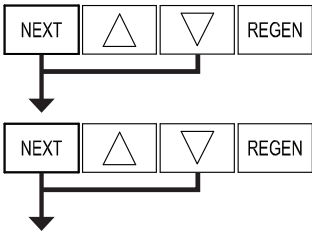

Step 1CS — Press NEXT and ▼ simultaneously for 5 seconds and release. Press NEXT and ▲ simultaneously for 5 seconds and release. If the screen in Step 2CS does not appear, the lock on the valve is activated. To unlock, press ▼, NEXT, ▲ and REGEN in sequence, then press NEXT and ▼ simultaneously.

Step 2CS

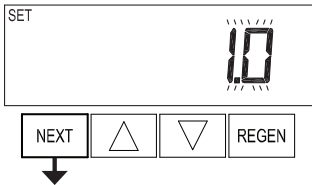

Step 2CS — Use ▲ or ▼ to select 1.0 for 1" valve, 1.25 for 1.25" valve, 2.0 for 2" valve or 1.0T for twin valve. Press NEXT to go to Step 3CS. Press REGEN to exit Configuration Settings.

Step 3CS

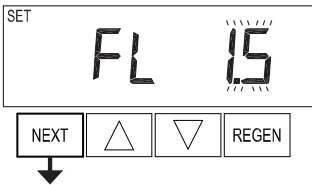

Step 3CS — If 1.5 or 2.0 is selected in Step 2CS, an additional screen will appear. It is used to select which size flow meter is to be used with the valve. 1.0r, 1.5, 2.0, or 3.0. Variable meter pulses of 0.1-150.0 PPG can also be selected. Press NEXT to go to Step 4CS. Press REGEN to return to the previous step.

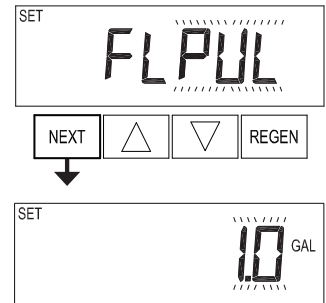

Step 4CS

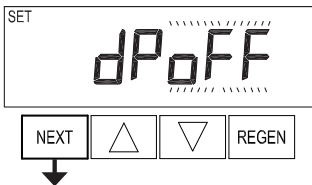

Step 4CS — Selecting the use of an outside signal to initiate a regeneration. Selection only matters if a connection is made to the two pin connector labelled DP SWITCH located on the printed circuit board. Following is an explanation of the options:

oFF - feature not used.

NOTICE In a twin alternating system each control must have a separate dP signal or dP switch. One DP signal.

on0 — If the dP switch is closed for an accumulative time of 2 minutes a regeneration will be signaled to the unit. In a twin alternating system the MAV will transition first to switch units so that the signaled unit can start regeneration. After the MAV has fully transitioned, the regeneration begins immediately.

NOTICE For CWS-150 control valves programmed for twin alternating: if the dP function "on0" is set, the Delayed Rinse and Fill feature is not available.

dEL — If the dP switch is closed for an accumulative time of 2 minutes a regeneration will occur at the scheduled delayed regeneration time. In a twin alternating system once the dP switch is triggered the PC Board will display "REGEN TODAY" and when the delayed regen time comes the control will switch tanks and the triggered unit will then go into regeneration.

NOTICE For CWS-150 control valves programmed for twin alternating: if the dP function "dEL" is set, the Delayed Rinse and Fill feature is not available.

HoLd — If the dP switch is closed a regeneration will be prevented from occurring while there is switch closure. In a twin alternating system the regeneration of a unit can be prevented upon switch closure. If the unit depletes the capacity down to zero, it will not be allowed to switch tanks to regenerate until the switch is open.

NOTICE For CWS-150 control valves programmed for twin alternating the Delayed Rinse and Fill feature can be set. Press NEXT to go to Step 5CS. Press REGEN to return to previous step.

Controller Programming and Operation

Step 5CS

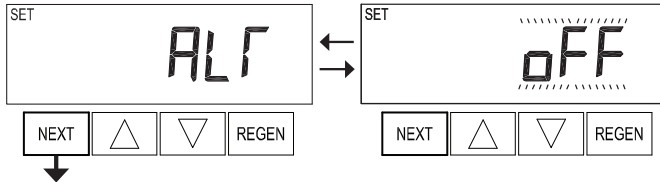

Select OFF when none of these features are used.

Step 5CS – This display will not appear if 1.0T was selected in Step 2CS. Allows selection of one of the following using ▲ or ▼.

- the Control Valve to have no hard water bypass;
- the Control Valve to act as an alternator;
- the Control Valve to have a separate source during the regeneration cycle; or
- the Control Valve to operate with the System Controller.

Only use Watts No Hard Water Bypass Valves or Watts Motorized Alternating Valves (MAV) with these selections. Watts No Hard Water Bypass Valves (1" or 1.25" V3070FM) are not designed to be used with the alternator or separate source functions.

Configuring the Control Valve for No Hard Water Bypass Operation:



Select nHbP for control operation. For no hard water bypass operation the three wire communication cable is not used.

Selection requires that a connection to MAV or a Watts No Hard Water Bypass Valve is made to the two pin connector labeled MAV located on the printed circuit board. If using a MAV, the A port of the MAV must be plugged and the valve outlet connected to the B port. When set to nHbP the MAV will be driven closed before the first regeneration cycle that is not FILL or SOFTENING or FILTERING, and be driven open after the last regeneration cycle that is not FILL.

NOTICE

If the control valve enters into an error state during regeneration mode, the MAV will return to the open position, if not already there.



Configuring the Control Valve for Separate Source Operation:

Select SEPS for control operation. For separate source operation the three wire communication cable is not used.

Selection requires that a connection to a Watts Motorized Alternator Valve (MAV) is made to the two pin connector labeled MAV located on the printed circuit board. The C port of the MAV must be connected to the valve inlet and the A port connected to the separate source used during regeneration. The B port must be connected to the feed water supply.

When set to SEPS the MAV will be driven closed before the first regeneration cycle, and be driven open after the last regeneration cycle.

NOTICE

If the control valve enters into an error state during regeneration mode, the MAV will return to the open position, if not already there.

Selecting the Control Valve to act as an alternator:

519.0 and higher – Use 3-wire Interconnect Cables for all communication between units.

518.3 and lower – Use 2-wire Interconnect Cables for twin alternators with independent flow meters.

Prior to starting the programming steps, connect the communication cable to each control valve board's three pin connector labeled 'COMM CABLE'
Also connect the meter cord to either control valve to the three pin connector labeled 'METER'

Configuration Settings	Softener Valve Programming Steps		
	Step 5CS	Set to ALT A Connect the outlet plumbing of ALT A valve to the MAV's A port and connect the MAV's two pin wire connector to the two pin connector labeled "DRIVE" on the ALT A valve	Set to ALT b Connect the outlet plumbing of ALT b valve to the MAV's B port. No electrical connections are required between the ALT b valve and the MAV
Softener System Setup	Step 10S	Set System Capacity	Set System Capacity
Softener System Setup	Step 11S	Set to "AUTO"	Set to "AUTO"
Softener System Setup	Step 12S	Set regeneration time option to 'on 0'	Set regeneration time option to 'on 0'
Installer Display Settings	Step 3I	Set Day Override to "oFF"	Set Day Override to "oFF"

If set up for a filter, in Step 5F set Volume Capacity in Gallons; in Step 6F select Regeneration Time Option "on 0" and in Step 3I select Day Override "oFF"

NOTICE

If the control valve is in an error state during regeneration mode the MAV will close the B port and keep open the A port until the error is corrected and reset.

Controller Programming and Operation

CWS-150 Valves

For Watts twin alternator systems using CWS-150 valves there will be an option to delay the last two cycles of regeneration (only "Rinse" and "Fill"). This feature splits the regeneration into two portions. The first portion of the regeneration will start immediately and all programmed cycles before the "Rinse" and "Fill" cycles will be performed. After all programmed cycles before "Rinse" and "Fill" are completed the control valve will drive to the service position (displaying "Delayed Rinse + Fill Pending"). When the volume of the on-line unit is depleted to 10% of its programmed capacity, the control valve will be triggered to finish the second portion of the regeneration and complete the "Rinse" and "Fill" cycles and return to Service and be placed into Standby mode, and wait to come on-line for service. Set to OFF to deactivate this feature.

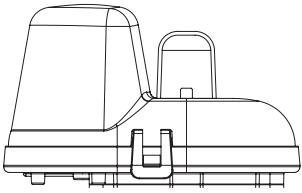
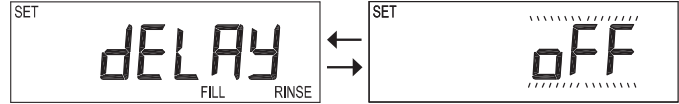

Retracted

Valve "A" in Service Position =
MAV piston rod Retracted

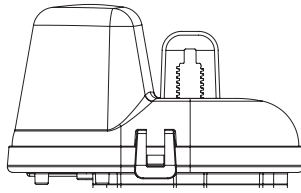

Extended

Valve "B" in Service Position =
MAV piston rod Extended

Watts Twin Alternator Operations

- Twin alternating systems can be programmed with a day override setting combined with the normal volume-based regeneration programming. A twin alternating system in this configuration will then regenerate based on the volume used or the day override if there is a period of low water usage.
- Twin alternating systems can be programmed as a time clock only based regenerating system. In this configuration, the days remaining are counted only on the unit that is in service. The unit in Stand-by Mode only notes days in diagnostics, which results in time clock only twin regeneration initiation.
- Twin alternating systems can be programmed for a delayed regeneration time. The system will allow an immediate transfer of the MAV to switch tanks and place a fully regenerated unit in service once a unit becomes exhausted. The exhausted unit will then be placed into Stand-by Mode and allowed to have a delayed regeneration at the pre-set time.

Controller Programming and Operation

Configuring the Control Valve for System Controller Operation:

Select "SYS" to link control valve to System Controller. For communication between control valve and System Controller, a three-wire communication cable is required.

Selection requires that a connection to a Watts No Hard Water Bypass (V3097/ BSPT or V3098/ BSPT) be made to the two-pin connector labeled MAV located on the printed circuit board for CWS-150 control valves.

Press NEXT to go to Step 6CS. Press REGEN to return to previous step.

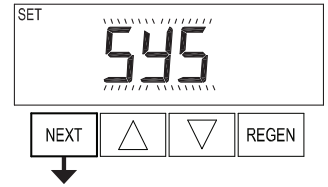

Step 6CS

Step 6CS – Fill Units: If set as a softener, if Step 2CS is set to 1.5, and FILL is part of the Regeneration Cycle Sequence, FILL UNITS of MIN or LBS can be selected. Press NEXT to exit OEM Configuration Setup. Press REGEN to return to previous step.

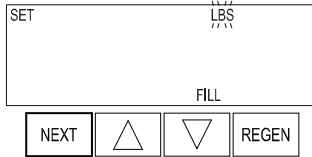

EXIT TO DISPLAY SCREENS



Controller Programming and Operation

OEM Softener System Setup

Step 1S

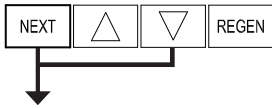

Step 1S – Press NEXT and ▼ simultaneously for 5 seconds and release. If screen in Step 2S does not appear, the lock on valve programming has been activated. To unlock press ▼, NEXT, ▲, REGEN in sequence, then press NEXT and ▼ simultaneously for 5 seconds and release.

Step 2S

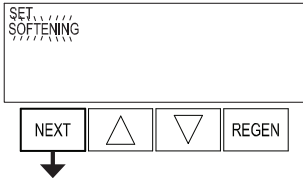

Step 2S – Choose SOFTENING using ▲ or ▼. Press NEXT to go to Step 3S. Press REGEN to exit OEM Softener System Setup.

Step 3S

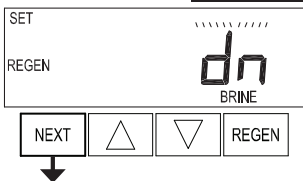

Step 3S – Choose Brining Direction using ▲ or ▼. This screen is not viewed when Step 2S is set to Filtering. Press NEXT to go to Step 4S. Press REGEN to return to previous step.

Step 4S

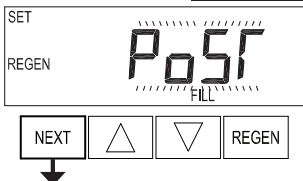

Step 4S – Set Refill location using ▲ or ▼:

- “PoST” to refill the brine tank after the final rinse; or
- “PrE” to refill the brine tank four hours before the regeneration time set. This screen is not viewed when Step 2S is set to Filtering. Press NEXT to go to Step 5S. Press REGEN to return to previous step.

Step 5S

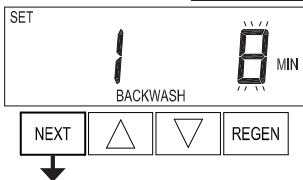

Step 5S – Select the time for the first cycle using ▲ or ▼. For valve types 1.5 and 2.0, “oFF” is also available. Press NEXT to go to Step 6S. Press REGEN to return to previous step.

Step 6S

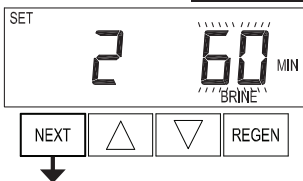

Step 6S – Select the time for the second cycle using ▲ or ▼. For valve types 1.5 and 2.0, “oFF” is also available.

NOTICE The display will flash between cycle number and time, and brine direction (UP or dn). Press NEXT to go to Step 7S. Press REGEN to return to previous step.

Step 7S

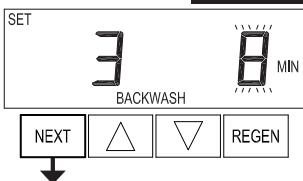

Step 7S – Select the time for the third cycle using ▲ or ▼. For valve types 1.5 and 2.0, “oFF” is also available.

Press NEXT to go to Step 8S. Press REGEN to return to previous step.

Step 8S

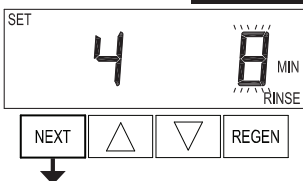

Select the time for the fourth cycle using ▲ or ▼. For valve types 1.5 and 2.0, “oFF” is also available. Press NEXT to go to Step 9S. Press REGEN to return to previous step.

Controller Programming and Operation

Step 9S



Step 9S – Select the pounds for the fifth cycle using ▲ or ▼. For valve types 1.5 and 2.0, “oFF” is also available.

NOTICE if Step 2CS is set to 2.0 or Step 6CS is set to MIN, Fill will be in minutes. Press NEXT to go to Step 10S. Press REGEN to return to previous step.

Step 10S



Step 10S – Set System Capacity using ▲ or ▼. The System Capacity setting should be based on the volume of resin and LBS of salt fill set in Step 9S. Press NEXT to go to Step 11S. Press REGEN to return to previous step.

Step 11S



Step 11S – Set Volume Capacity using ▲ or ▼. If value is set to:

- “AUTO” capacity will be automatically calculated and reserve capacity will be automatically estimated;
- “oFF” regeneration will be triggered by the day override setting, or can be set to regenerate on specific days of the week.
- a number, regeneration will be triggered by the value specified (in Gallons). If “oFF” or a volume is used, the hardness display will not be allowed to be set in Installer Display Settings Step 2I. See Setting Options Table for more detail. Press NEXT to go to Step 12S. Press REGEN to return to previous step.

Step 12S



Step 12S – Set Regeneration Trigger using ▲ or ▼. If Step 11S is set to OFF, Regeneration Trigger can be set to 28 day or 7 day. Press NEXT to go to Step 13S. Press REGEN to return to previous step.



Step 13S



Step 13S – Set Regeneration Time Options using ▲ or ▼.

NOTICE This step will not appear if Step 11S is set to oFF or Step 5CS is set to “SYS”.

If value is set to:

- “NORMAL” means regeneration will occur at the preset time;
- “on 0” means regeneration will occur immediately when the volume capacity reaches 0 (zero); or
- “NORMAL + on 0” means regeneration will occur at one of the following:— the preset time when the volume capacity falls below the reserve or the specified number of days between regenerations is reached whichever comes first; or— immediately after 10 minutes of no water usage when the volume capacity reaches 0 (zero). “NORMAL” is the default if Step 5CS is set to ALT A or ALT B, and “NORMAL + on 0” is not available. “on 0” is the default if Step 2CS is set to 1.0T, and “NORMAL + on 0” is not available. See Setting Options Table for more detail. Press NEXT to go to Step 14S. Press REGEN to return to previous step.

Step 14S



Step 14S – Set Relay Operation using ▲ or ▼. The choices are:

- Time on: Relay activates after a set time at the beginning of a regeneration and then deactivates after a set period of time. The start of regeneration is defined as the first backwash cycle or Dn brine cycle, whichever comes first.
- Gallons Softening on: Relay activates after a set number of gallons have been used while in service and then deactivates after the meter stops registering flow and the set time period has expired.
- Gallons Softening Regen on: Relay activates after a set number of gallons have been used while in service, or during regeneration, and then deactivates after the meter stops registering flow and the set time period has expired.
- ERROR: Relay closes whenever the valve enters error mode, and immediately deactivates when error mode is exited. If set to ERROR, Steps 15S and 16S will not be shown.
- Off: If set to Off, Steps 15S and 16S will not be shown. Press NEXT to go to Step 15S. Press REGEN to return to previous step. Step 14S

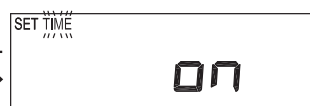

Controller Programming and Operation

Step 15S

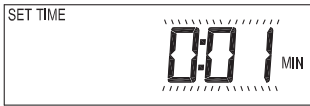

Step 15S – Set Relay Actuation Time or Gallons using ▲ or ▼. The choices are:

- Relay Actuation Time: After the start of a regeneration the amount of time that should pass prior to activating the relay. The start of regeneration is defined as the first backwash cycle, Dn brine cycle or UP brine cycle whichever comes first. Ranges from 1 second to 200 minutes.
- Relay Actuation Gallons:

Relay activates after a set number of gallons has passed through the meter. Ranges from 1 to 200 gallons. Press NEXT to go to Step 16S. Press REGEN to return to previous step.

Step 16S

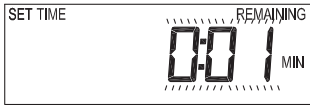

Step 16S – Set Relay Deactivate Time using ▲ or ▼.

- If Set Time on is selected in Step 14S the relay will deactivate after the time set has expired. Ranges from 1 second to 200 minutes.
- If Set Gallons Softening on or Set Gallons Softening Regen on is selected in Step 14S the relay will deactivate after the time set has expired or after the meter stops registering flow, whichever comes first. Ranges from 1 second to 20 minutes.

Press NEXT to exit OEM Softener System Setup. Press REGEN to return to previous step.

EXIT OEM SOFTENER SYSTEM SETUP

Controller Programming and Operation

Setting Options Table

Volume Capacity	Regeneration Time Option	Day Override	Result ¹
AUTO	Normal	oFF	Reserve capacity automatically estimated. Regeneration occurs when volume capacity falls below the reserve capacity at the next Regen Set Time.
AUTO	Normal	Any number	Reserve capacity automatically estimated Regeneration occurs at the next Regen Set Time when volume capacity falls below the reserve capacity or the specified number of days between regenerations is reached.
AUTO	On 0	oFF	Reserve capacity <u>NOT</u> automatically estimated. Regeneration occurs immediately when volume capacity reaches 0. Time of regeneration will not be allowed to be set because regeneration will always occur when volume capacity reaches 0.
AUTO	Normal on 0	oFF	Reserve capacity automatically estimated Regeneration occurs when volume capacity falls below the reserve capacity at the next Regen Set Time or regeneration occurs after 10 minutes of no water usage when volume capacity reaches 0.
AUTO	Normal on 0	Any number	Reserve capacity automatically estimated Regeneration occurs at the next Regen Set Time when volume capacity falls below the reserve capacity or the specified number of days between regenerations is reached or regeneration occurs after 10 minutes of no water usage when volume capacity reaches 0

¹ Reserve Capacity estimate is based on history of water usage. Reserve Capacity estimate is not available with alternator systems or Twin Tank Valve.

Controller Programming and Operation

Installer Display Settings - Regeneration Type Auto

Step 1I



Step 1I – To enter Installer Display press NEXT and ▲ simultaneously for about 5 seconds and release.

Step 2I



Step 2I – Hardness: Set the amount of influent hardness using ▲ or ▼. This display will not be viewed if FILTERING BACKWASH or FILTERING REGEN is selected in Step 2F or if “oFF” or a number was selected in Step 11S.

Press NEXT to go to step 3I. Press REGEN to exit Installer Display Settings.

Step 3I

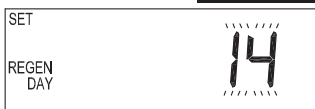

Step 3I – Day Override: When volume capacity is set to “oFF”, sets the number of days between regenerations. When volume capacity is set to AUTO or to a volume, sets the maximum number of days between regenerations. If value set to “oFF”, regeneration initiation is triggered solely by volume used. If value is set in days (allowable range from 1 to 28) regeneration initiation will be called for on that day regardless of actual water usage. Set Day Override using ▲ or ▼:

- number of days between regeneration (1 to 28); or
- “oFF”. See Setting Options Table for more detail on setup. Press NEXT to go to step 4I. Press REGEN to return to previous step.

Step 4I



Step 4I – Next Regeneration Time (hour): Set the hour of day for regeneration using ▲ or ▼. The default time is 2:00. This display will show “REGEN on 0 GAL” if “on 0” is selected in Set Regeneration Time Option in OEM Softener System Setup or OEM Filter System Setup.

Press NEXT to go to step 5I. Press REGEN to return to previous step.

Step 5I



Step 5I – Next Regeneration Time (minutes): Set the minutes of day for regeneration using ▲ or ▼. This display will not be shown if “on 0” is selected in Set Regeneration Time Option in OEM Softener System Setup or OEM Filter System Setup.

Press NEXT to exit Installer Display Settings. Press REGEN to return to previous step.

EXIT INSTALLER DISPLAY SETTINGS

Controller Programming and Operation

Installer Display Settings - 7 Day Regeneration

Step 1I



Step 1I – To enter Installer Display press NEXT and ▲ simultaneously for about 5 seconds and release.

Step 2I



Step 2I – Use ▲ or ▼ to set the current day of the week.

Default = 4 (Wednesday)

1 = SUNDAY

2 = MONDAY

3 = TUESDAY

4 = WEDNESDAY

5 = THURSDAY

6 = FRIDAY

7 = SATURDAY

Press NEXT to go to Step 3I. Press REGEN to exit Installer Display.

Step 3I



Step 3I – Scroll through days 1 to 7 using NEXT. Use ▲ or ▼ to turn regen ON or OFF for each individual day. After completing the 7th day, press NEXT to go to Step 4I. Press REGEN to go to previous display.

Step 4I



Step 4I – Next Regeneration Time (hour): Set the hour of day for regeneration using ▲ or ▼. The default time is 2:00. Press NEXT to go to step5I. Press REGEN to return to previous step.

Step 5I

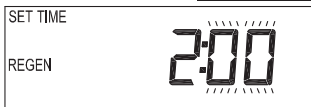

Step 5I – Next Regeneration Time (minutes): Set the minutes of day for regeneration using ▲ or ▼. Press NEXT to exit Installer Display Settings. Press REGEN to return to previous step.

Controller Programming and Operation

Diagnostics

Step 1D

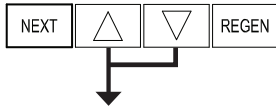

Step 1D – Press ▲ or ▼ simultaneously for 5 seconds and release. If screen in Step 2D does not appear the lock on the valve is activated. To unlock press ▼, NEXT, ▲, REGEN in sequence, then press ▲ and ▼ simultaneously for 5 seconds and release.

Step 2D

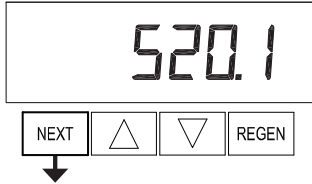

Step 2D – Software Version. Press NEXT to go to Step 3D. Press REGEN to exit Diagnostics.

Step 3D

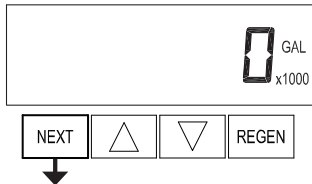

Step 3D – Volume, total used since start-up: This display shows the total gallons treated since startup. This display will equal zero if a water meter is not installed. Press the NEXT button to go to Step 4D. Press REGEN to return to previous step.

Step 4D

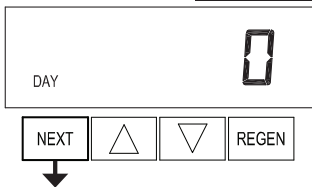

Step 4D – Days, total since start-up: This display shows the total days since startup. Press the NEXT button to go to Step 5D. Press REGEN to return to previous step.

Step 5D

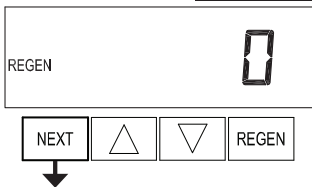

Step 5D – Regenerations, total number since start-up: This display shows the total number of regenerations that have occurred since startup. Press the NEXT button to go to Step 6D. Press REGEN to return to previous step.

Step 6D



Step 6D – Error Log: This display shows a history of the last 10 errors generated by the control during operation. Press ▲ or ▼ to view each recorded error. Press NEXT to go to Step 7D. Press REGEN to return to previous step.

Step 7D

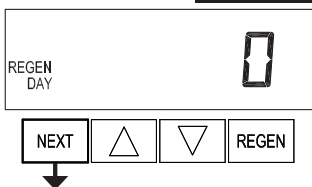

Step 7D – Days, since last regeneration: This display shows the days since the last regeneration occurred. Press NEXT to go to Step 8D. Press REGEN to return to previous step.

Step 8D

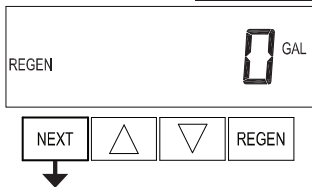

Step 8D – Volume, since last regeneration: This display shows the volume of water that has been treated since the last regeneration. This display will equal zero when a water meter is not installed. Press NEXT to go to Step 9D. Press REGEN to return to previous step.

Controller Programming and Operation

Step 9D

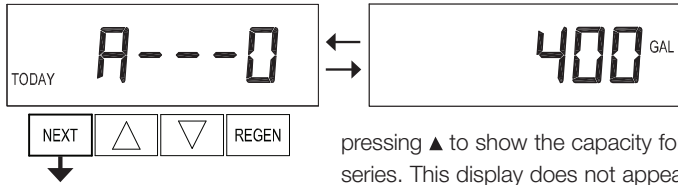

pressing ▲ to show the capacity for days 3, 4, 5 and 6. ▼ can be pressed to move backwards in the day series. This display does not appear if 1.0 is set in Step 2CS, if ALT A or ALT B are selected in Step 5CS, or anytime the reserve capacity is not determined by the control.

Press NEXT at any time to go to Step 10D. Press REGEN to return to previous step.

Step 9D – Volume, reserve capacity used for last 7 days: If the valve is set up as a softener, a meter is installed, and Set Volume Capacity is set to “Auto,” this display shows day 0 (for today) and flashes the reserve capacity. Pressing ▲ will show day 1 (which would be yesterday) and flashes the reserve capacity used. Pressing ▲ again will show day 2 (the day before yesterday) and the reserve capacity. Keep

Step 10D

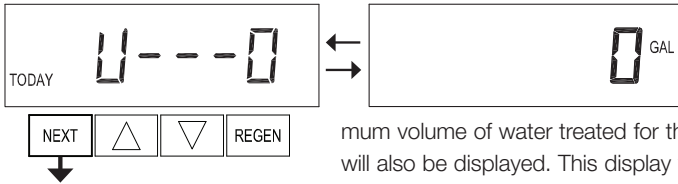

maximum volume of water treated for the last 63 days. If a regeneration occurred on the day the word “REGEN” will also be displayed. This display will show dashes if a water meter is not installed.

Press NEXT at any time to go to Step 11D. Press REGEN to return to previous step.

Step 10D – Volume, 63-day usage history: This display shows day 0 (for today) and flashes the volume of water treated today. Pressing ▲ will show day 1 (which would be yesterday) and flashes the volume of water treated on that day. Continue to press ▲ to show the maxi

Step 11D

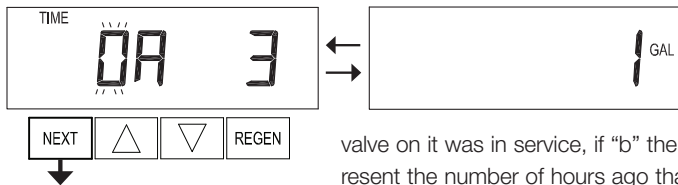

valve on it was in service, if “b” the tank with the in/out head on it was in service. The next three digits represent the number of hours ago that the transfer occurred. The display alternates with the volume that was treated before the tank transferred.

Press NEXT at any time to go to Step 12D. Press REGEN to return to previous step.

Step 11D – Twin Tank Valve transfer history: only displays when 1.0 was selected in Step 2CS. Use ▲ or ▼ to scroll through the last 10 tank transfers. The first position in the display ranges from 0 to 9 with the lowest number being the most recent transfer. The second position in the display will be either “A” or “b”. If “A” then the tank with the

Step 12D

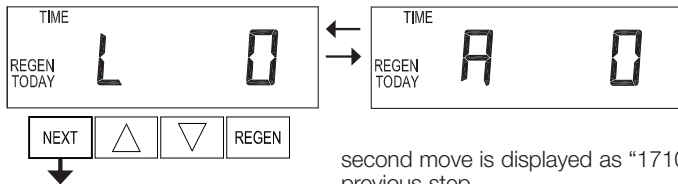

second move is displayed as “1710”. Press NEXT at any time to go to Step 13D. Press REGEN to return to previous step.

Step 12D – MAV Drive History in the direction of retracted piston rod position. Display will only be shown if 1.0 is selected in Step 2CS, or OFF is not selected in Step 5CS. Up to a four digit number will appear after the “L” which stands for latest and “A” which stands for average. Drive time is measured in 1/100 of a second; i.e., a 17.10

DIAGNOSTICS Press and hold ▲ and ▼ buttons for 3 seconds while in Step 12D to reset the MAV drive history in both the retracted and extended piston rod position. To view the old MAV drive history data for retracted and extended rod position press and hold REGEN and ▲ while in Step 12D. Press NEXT to advance display to the old MAV drive history.

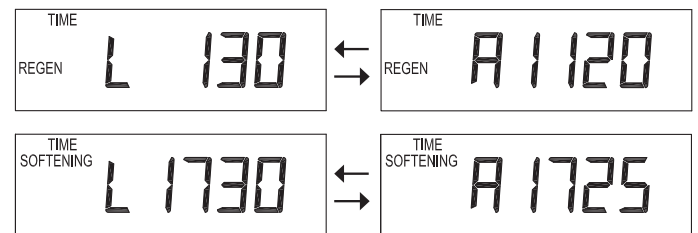

Step 13D

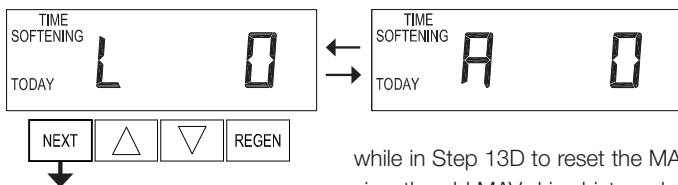

while in Step 13D to reset the MAV drive history in both the extended and retracted piston rod position. To view the old MAV drive history data see Step 12D.

Press NEXT at any time exit Diagnostics. Press REGEN to return to previous step.

Step 13D – MAV Drive History in the direction of extended piston rod position. Display will only be shown if 1.0 is selected in Step 2CS, or OFF is not selected in Step 4CS. Up to a four digit number will appear after the “L” which stands for latest and “A” which stands for average. Drive time is measured in 1/100 of a second; i.e., a 17.15 second move is displayed as “1715”. Press and hold ▲ and ▼ for 3 seconds

EXIT DIAGNOSTICS

Replacing the Media

NOTICE

Ion exchange resin may need to be replaced periodically due to physical breakdown caused by chlorine/chloramine disinfectants, or fouling caused by certain metals such as iron and manganese.

1. Mark the location of the mineral tanks on the floor incase they need to be moved once all water, resin and gravel has been removed. This will help with realignment of the plumbing after media replacement. DO NOT attempt to move a mineral tank that contains media and or water.
2. Open the bypass valve.
3. Close the inlet and outlet isolation valves for the mineral tank needing media replacement
4. Locate "Regeneration Cycles and Times" on page 14 for the controller.
5. Follow the steps to place the system in the backwash position. This relieves any pressure inside the mineral tank. Once the system cycles into the backwash position, unplug the control valve from the power outlet to keep the system in the backwash position.
6. Disconnect the inlet, outlet, and drain union plumbing fittings. Then, if necessary for the removal of the control valve from the mineral tank, remove the remaining plumbing from the inlet, outlet and drain ports of the control valve.
7. Disconnect the meter cable from the control board.
8. Disconnect the brine tubing from the control valve's brine connection port.
9. Unplug the power cord.
10. Remove the control valve from the mineral tank by turning the control valve counter-clockwise when viewed from above. Keeping a firm grip on the control valve, continue to rotate until it can be lifted off of the top of the mineral tank. Store the control valve in a safe location.
11. Note the top of the distributor tube. It must be flush with the top of the tank. If it is above the top of the tank by more than $\frac{1}{2}$ " the distributor tube may have become disconnected from the distributor screen in the bottom of the mineral and must be reconnected.
12. Obtain a length of $\frac{3}{4}$ " sch. 40 PVC that is the same height as the mineral tank and a length of 1" clear braided poly-vinyl hose. The hose must be long enough to reach the nearest floor drain. (Both of these can be acquired at a local hardware store).
13. Insert one end of the pipe inside the hose and the other end of the pipe into the top of the mineral tank and down into the resin media. Put the other end of the hose inside a water permeable bag and locate the bag over the floor drain.
14. Insert a garden hose into the bag side of the poly-vinyl hose to fill the hose and PVC pipe with water. Air will bubble out of the tank. Once all the air is out of the hose and pipe, remove the garden hose from the polyvinyl hose to establish a siphon. The resin can then be siphoned into the bag. Use the garden hose to maintain a full water level in the mineral tank to. The bag end of the poly-vinyl hose must remain lower in elevation then the end of the PVC pipe in the mineral tank to maintain the siphon. The bag will retain the resin while the water flows down the drain. Use caution not to allow resin to enter the floor drain.
15. Continue to siphon resin until it is completely evacuated from the mineral tank. Gravel will clogged the siphon hose and, if it must be removed due to fouling, or to repair or replace a damaged distributor tube and screen, must be evacuated by other means.
16. If replacing gravel, inspect lower distributor screens for damage and replace if necessary.
17. To add new media and reconnect control valve to mineral tank follow General Installation steps 3-4K located on page 9 of this manual.
18. Reconnect inlet, outlet, and drain plumbing to the control valve and tighten the plumbing union fittings on each of these plumbing lines.
19. Reconnect brine tubing to brine connection port of control valve.
20. Reconnect meter cable.
21. Open the inlet isolation valve slightly, until water can be heard flowing through the isolation valve and allow the mineral tank to fill with water. Air will come out of the drain line until the mineral tank is full of water. Once water flow at the drain line is observed, fully open the inlet valve and allow water flow to drain for 10 minutes to flush the resin bed of any color. If water at the drain shows any discoloration, continue to flush the resin bed until water at the drain is clear.
22. Plug the system back in to the power outlet so that it will return to the service position.
23. Fully open inlet and outlet isolation valves and close bypass valve.
24. Check for leaks and repair as required.
25. Open hot and cold side of a treated water faucet to flush any air from the plumbing system.

If this is a multi-tank system replace media in each mineral tank according to this media replacement procedure.

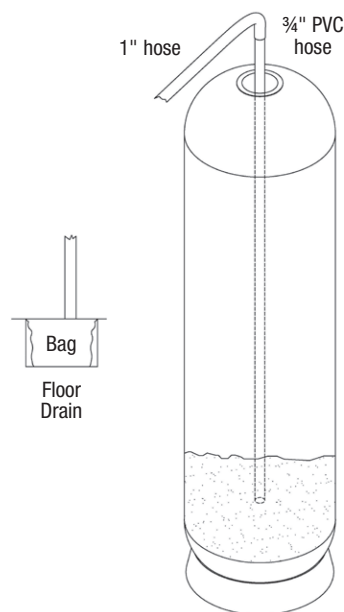

Replacement Parts - Major System Components

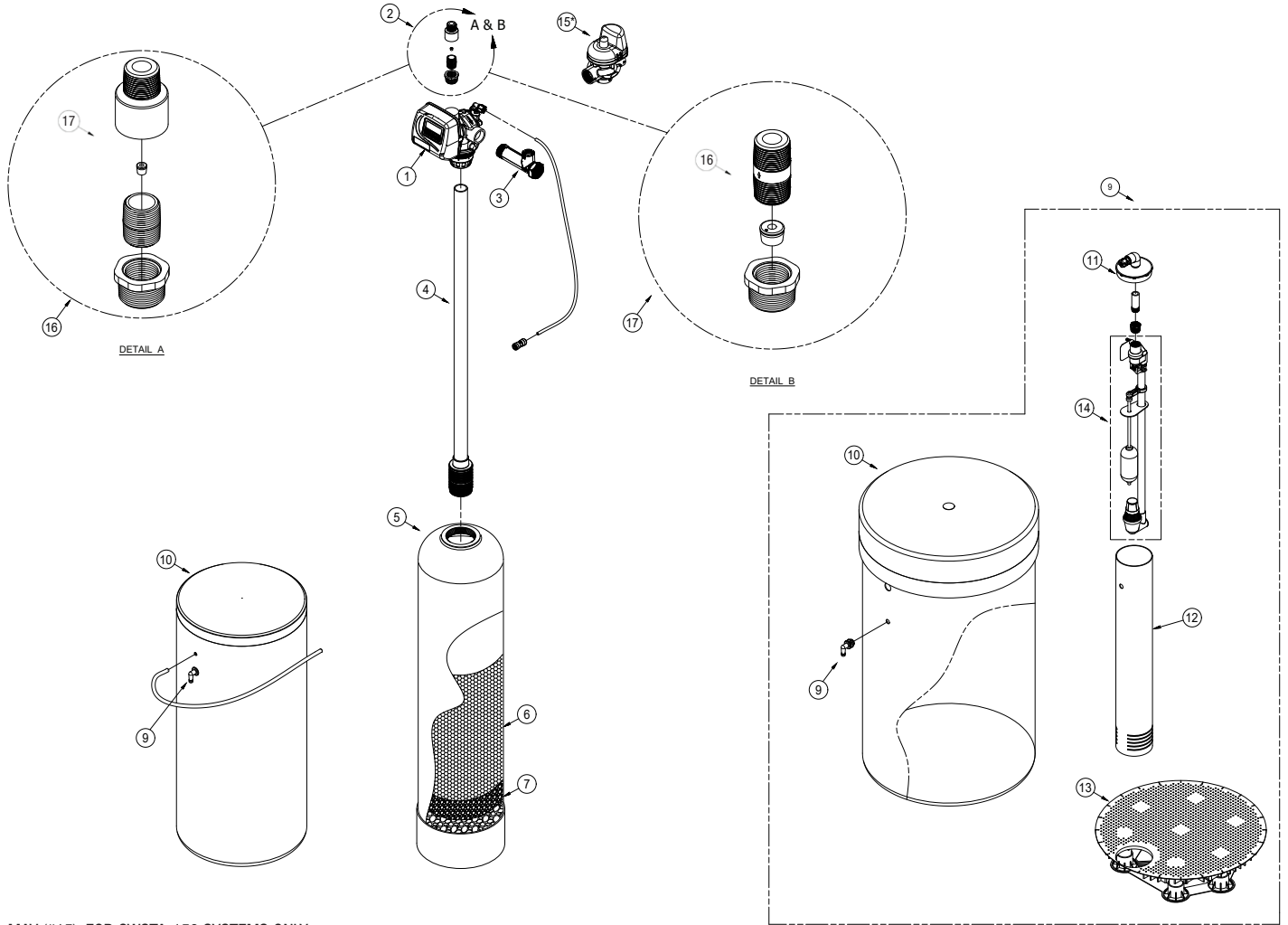

MAV (#15): FOR CWSTA-150 SYSTEMS ONLY

Replacement Parts - Major System Components

MAJOR SYSTEM COMPONENTS		
ITEM NO.	ORDERING CODES	DESCRIPTION
1	68104827	KC10V15EEDTF VALVE WS1.5 TC DF 18 WO/BP, TAILS
2	68108489	V2003-C-MCH FC PVC DRAIN FLOW CONTROL PVC 1" HOUSING F/ .25-3.5 GPM BUTTONS
2	68108491	V2003-MCH FC PVC DRAIN FLOW CONTROL 1" MXM HSG F/5-10 GPM
2	68108487	V2003-A-MCH FC PVC 1 MXM HSG F/12 15 20 GPM
3	68104915	KC11V3040 VLV RMT MTR EL
4	68101197	D5007 DIS RISER R2A PP 1.5X72
5	68100748	C1094-4N FTK 12X52 ALM POLY 4.0 W/BASE(9/CASE)
5	68100997	C9098 FTK 14X65 NAT 4T POLY W/BASE
5	68101000	C9099-4 FTK 16X65 NAT 4TW/BASE
5	68100691	C1029 FTK 18X65 ALM COMP 4.0 TOP W/BASE
5	68100694	C1030 FTK 21X62 ALM COMP4.0 TOP W/STD BASE
5	68100698	C1031 FTK 24X72 NAT COMP4.0 TOP ONLY W/STD BASE
6	68100326	A4000 RSN C1 HICAP SOFTENER CATION
7	68100354	A7005A MEDIA GRAVEL FLINT #20 .125X.0625 50#/BAG
8	68102491	G2002BS TNK-BRI ASSY 18X40 BLK W/474 WELL CAP GR
9	68102593	H1018 BRINE OVERFLOW SET WHT (2 PC) CLK
10	68102494	G2003 TNK-BRI 24X41 BLKCLK
10	68102511	G2009 TNK-BRI 30X50 BLK W/BLOW MOLDED COVER
11	68102592	H1017 BRINE WELL CAP 5.0
12	68102606	H1071 BRINE WELL 5.0X60AWR
13	68102608	H1075 BRINE GRID SET 24" MINIMUM SALTING (5" LEGS)
14	68102639	H7050 BRINE ASSY SBV 2350 W/COMM AIR CHECK .75 F
15	68108938	WST-PCL-V3071 WCS MOTORIZED ALTERNATOR VLV 1.5 F
16	68108568	V7102-3.5 FC BUTTON 3.5GPM
17	68108569	V7103-05 FC BUTTON 5.0 GPM BLU
17	68108571	V7103-07 FC BUTTON 7.0 GPM DARK BROWN
17	68108575	V7103-12 FC BUTTON 12.0 GPM BLK
17	68108576	V7103-15 FC BUTTON 15.0 GPM BLK

Replacement Parts - CWS-150 Control Valve Body

CWS-150 DRIVE CAP ASSEMBLY, DOWNFLOW PISTON, UPFLOW PISTON, REGENERANT PISTON, SPACER STACK ASSEMBLY AND MAIN BODY

Item No.	Legacy No.	Description	Quantity
1	V3004	DRIVE CAP ASSEMBLY	1
2	V3135	O-RING 228	1
3	V3407	CWS-150 PISTON DOWNFLOW ASSEMBLY (AMBER IN COLOR)	1
	V4042	CWS-150 PISTON UPFLOW ASSEMBLY (BLACK IN COLOR)	
4	V3174*	REGENERANT PISTON	1
5	V3423	CWS-150 BACKPLATE DOWEL	1
6	V3430-01	CWS-150 SPACER STACK ASSEMBLY	1
7	V3178	BACK PLATE	1
8	V3410	O-RING 347	1
	V3641	O-RING 225 FOR VALVE BODIES WITH NPT THREADS	
9	V3441	O-RING 226 FOR VALVE BODIES WITH BSPT THREADS	1
	V3950-01	CWS-150 NPT VALVE BODY, W/V3468	
10	V3950BSPT-01**	CWS-150 BSPT VALVE BODY, W/V3465	1
	V3468	TEST PORT PLUG, 1/4" NPT	
NOT SHOWN	V3465	TEST PORT PLUG, 1/4" BSPT	2
	D1300	TOP BAFFLE DIFFUSER, 1.5/50MM	
11	D1300	TOP BAFFLE DIFFUSER, 1.5/50MM	1

* V3174 regenerant piston not used for backwash only valves. V3010-15Z injector plug and V3195-01 refill port plug assembly must be used for backwash only valves.

** BSPT threads on inlet and outlet ports on the V3950BSPT-01, NPT threads on drain port.

NOTICE

After completing any valve maintenance, press and hold NEXT and REGEN buttons for 3 seconds. This resets the electronics and establishes the service piston position. The display should flash all wording, then flash the software version and then reset the valve to the service position.

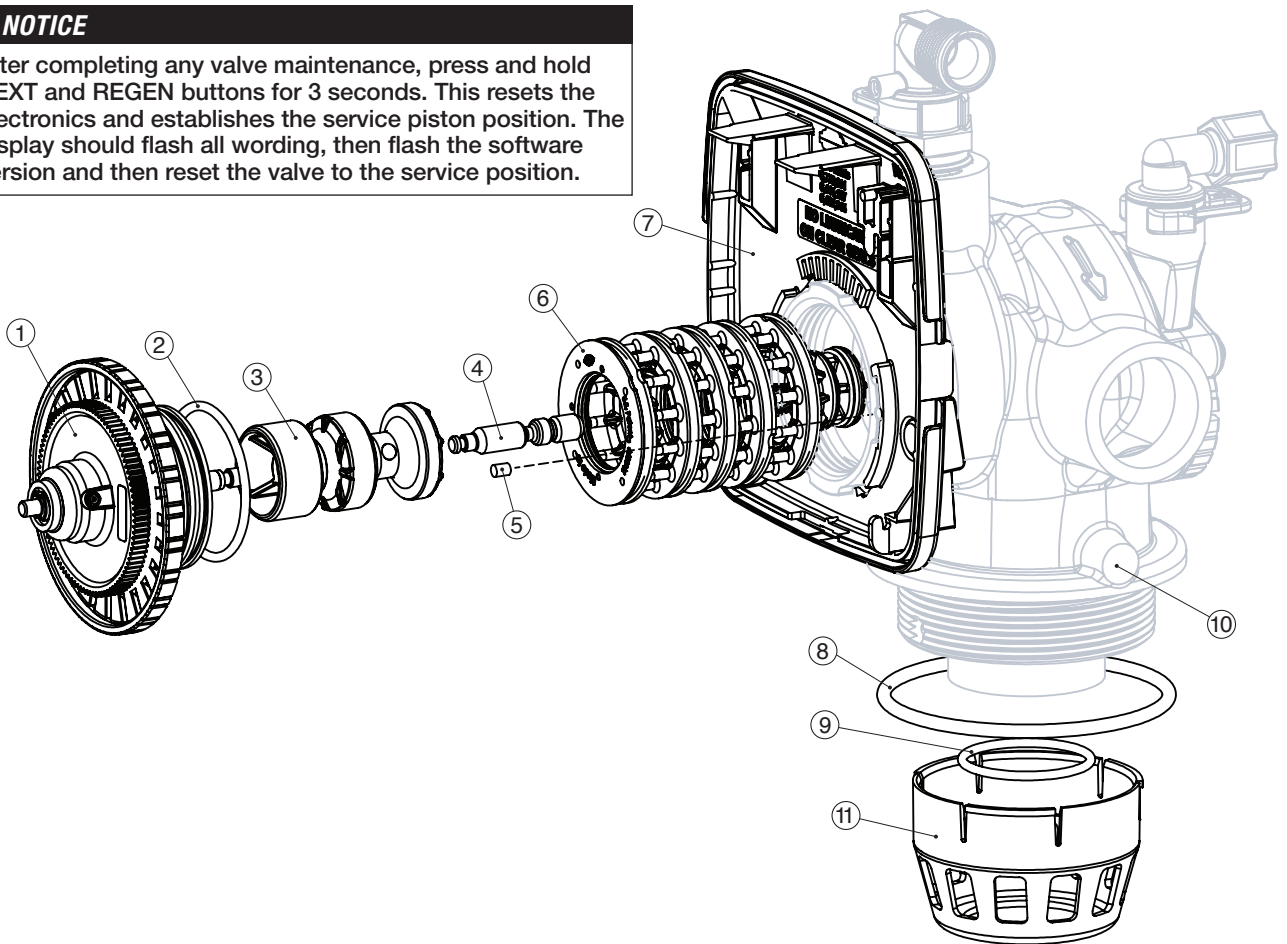

Replacement Parts - CWS-150 Regenerate Components

ITEM NO.	LEGACY NO.	DESCRIPTION	QUANTITY
1	V3967	CWS-150 INJECTOR BODY, WELDED ASSEMBLY	1
2	V3441	O-RING -226	1
3***	V3968	CWS-150 INJECTOR FEED TUBE DOWNFLOW (BLACK IN COLOR)	1
	V3968-01	CWS-150 INJECTOR FEED TUBE UPFLOW (GREY IN COLOR)	
4	V3177-01	INJECTOR SCREEN	1
5****	V3969	CWS-150 INJECTOR DRAW TUBE DOWNFLOW (BLACK IN COLOR)	1
	V3969-01	CWS-150 INJECTOR DRAW TUBE UPFLOW (GREY IN COLOR)	
6	V4349	WS15P INJECTOR CAP	1
7	V3152	O-RING -135	1
8	SEE PAGE 44	CWS-150 INJECTOR	1
9	V3498**	REFILL FLOW CONTROL, 1/2"	1
10	V3428**	CWS-150 REFILL RETAINER ASSEMBLY (0.5 GPM)	1
11	V3163	O-RING, -019	1
12	H4612	REGENERANT ELBOW W/FLOW CONTROL	1
13	JCPG-8PBLK	NUT, COMPRESSION, 1/2" BLACK	1
14	JCP-P-8	INSERT, POLYTUBE 1/2"	1
15	V3182	REFILL FLOW CONTROL (0.5 GPM)	1
16	H4615	RETAINING CLIP	1
17	V3724	WASHER, FLAT STAINLESS STEEL	4
18	V3642	BOLT, BHCS STAINLESS STEEL 1/4-20X 1-1/4	4
19	V3195-01	REFILL PORT PLUG ASSY	1

**Contains a V3182 0.5 gpm flow control

***V3968 and V3968-01 each contain one D1245 O-RING 111 and two V3155 O-RING 112

****V3969 and V3969-01 each contain one V3638 O-RING 113 and two V3157 O-RING 115

Proper RFC orientation directs refill water flow toward the washer face with radius and text.

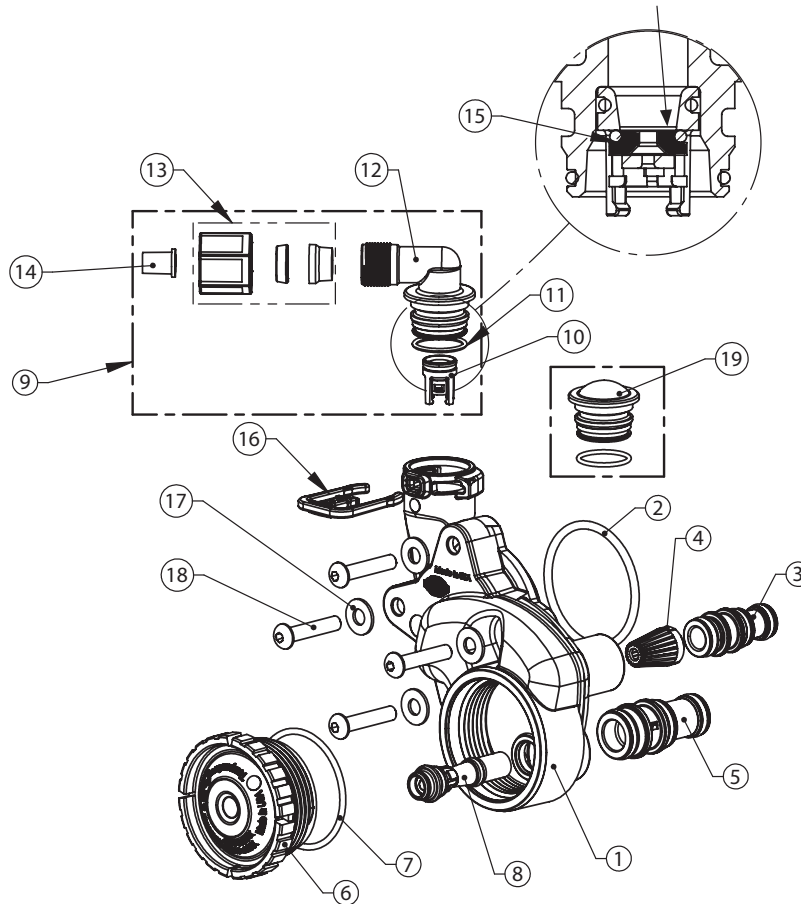

Replacement Parts - 1½" Stainless Electronic Turbine Meter Assembly

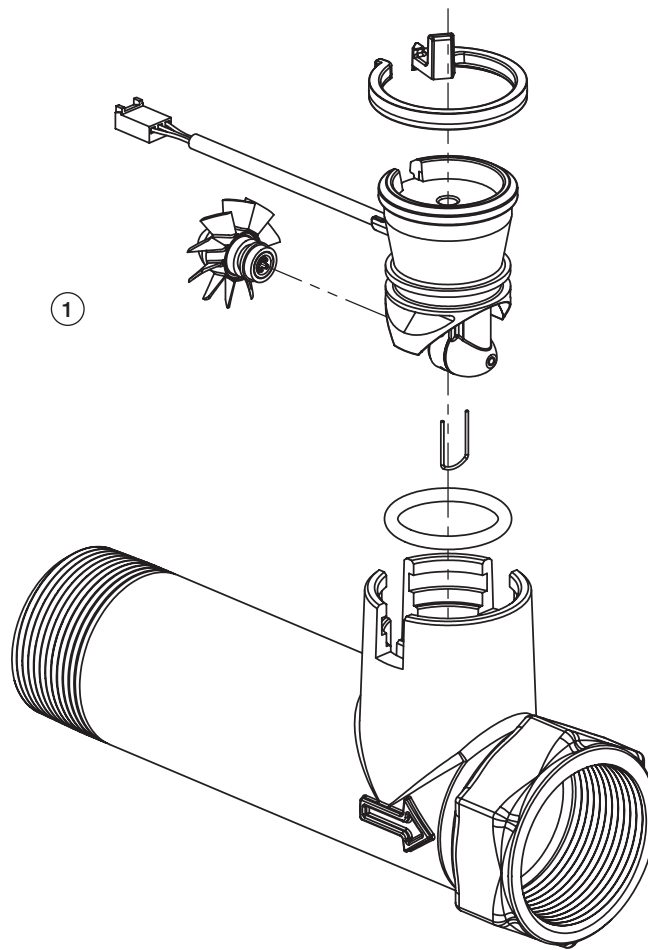

1½ INCH PLASTIC ELECTRONIC TURBINE METER ASSEMBLY			
ITEM NO.	QTY	ORDERING CODE	DESCRIPTION
1	1	68104915	KC11V3040 ELECTRONIC TURBINE METER 1.5" FPT WITH 15' CABLE S

Troubleshooting

Problem	Possible Cause	Solution
1. No Display on PC Board	a. No power at electric outlet	a. Repair outlet or use working outlet
	b. Control valve Power Adapter not plugged into outlet or power cord end not connected to PC board connection	b. Plug Power Adapter into outlet or connect power cord end to PC Board connection
	c. Improper power supply	c. Verify proper voltage is being delivered to PC Board
	d. Defective Power Adapter	d. Replace Power Adapter
	e. Defective PC Board	e. Replace PC Board
2. PC Board does not display correct time of day	a. Power Adapter plugged into electric outlet controlled by light switch	a. Use uninterrupted outlet
	b. Tripped breaker switch and/or tripped GFI	b. Reset breaker switch and/ or GFI switch
	c. Power outage	c. Reset time of day. If PC Board has battery back up present the battery may be depleted. See Front Cover and Drive Assembly drawing for instructions.
	d. Defective PC Board	d. Replace PC Board
3. Display does not indicate that water is flowing. Refer to user instructions for how the display indicates water is flowing	a. Bypass valve in bypass position	a. Turn bypass handles to place bypass in service position
	b. Meter is not connected to meter connection on PC Board	b. Connect meter to three pin connection labeled METER on PC Board
	c. Restricted/ stalled meter turbine	c. Remove meter and check for rotation or foreign material
	d. Meter wire not installed securely into three pin connector	d. Verify meter cable wires are installed securely into three pin connector labeled METER
	e. Defective meter	e. Replace meter
	f. Defective PC Board	f. Replace PC Board
4. Control valve regenerates at wrong time of day	a. Power outage	a. Reset time of day. If PC Board has battery back up present the battery may be depleted. See Front Cover and Drive Assembly drawing for instructions.
	b. Time of day not set correctly	b. Reset to correct time of day
	c. Time of regeneration set incorrectly	c. Reset regeneration time
	d. Control valve set at "on 0" (immediate regeneration)	d. Check programming setting and reset to NORMAL (for a delayed regen time)
	e. Control valve set at "NORMAL + on 0" (delayed and/ or immediate)	e. Check programming setting and reset to NORMAL (for a delayed regen time)
5. Time of day flashes on and off	a. Power outage	a. Reset time of day. If PC Board has battery back up present the battery may be depleted. See Front Cover and Drive Assembly drawing for instructions.
6. Control valve does not regenerate automatically when the REGEN button is depressed and held.	a. Broken drive gear or drive cap assembly	a. Replace drive gear or drive cap assembly
	b. Broken Piston Rod	b. Replace piston rod
	c. Defective PC Board	c. Defective PC Board
7. Control valve does not regenerate automatically but does when the REGEN button is depressed and held.	a. Bypass valve in bypass position	a. Turn bypass handles to place bypass in service position
	b. Meter is not connected to meter connection on PC Board	b. Connect meter to three pin connection labeled METER on PC Board
	c. Restricted/ stalled meter turbine	c. Remove meter and check for rotation or foreign material
	d. Incorrect programming	d. Check for programming error
	e. Meter wire not installed securely into three pin connector	e. Verify meter cable wires are installed securely into three pin connector labeled METER
	f. Defective meter	f. Replace meter
	g. Defective PC Board	g. Replace PC Board

Troubleshooting

Problem	Possible Cause	Solution
8. Hard or untreated water is being delivered	a. Bypass valve is open or faulty	a. Fully close bypass valve or replace
	b. Media is exhausted due to high water usage	b. Check program settings or diagnostics for abnormal water usage
	c. Meter not registering	c. Remove meter and check for rotation or foreign material
	d. Water quality fluctuation	d. Test water and adjust program values accordingly
	e. No regenerant or low level of regenerant in regenerant tank	e. Add proper regenerant to tank
	f. Control fails to draw in regenerant	f. Refer to Trouble Shooting Guide number 12
	g. Insufficient regenerant level in regenerant tank	g. Check refill setting in programming. Check refill flow control for restrictions or debris and clean or replace
	h. Damaged seal/stack assembly	h. Replace seal/stack assembly
	i. Control valve body type and piston type mix matched	i. Verify proper control valve body type and piston type match
	j. Fouled media bed	j. Replace media bed
9. Control valve uses too much regenerant	a. Improper refill setting	a. Check refill setting
	b. Improper program settings	b. Check program setting to make sure they are specific to the water quality and application needs
	c. Control valve regenerates frequently	c. Check for leaking fixtures that may be exhausting capacity or system is undersized
10. Residual regenerant being delivered to service	a. Low water pressure	a. Check incoming water pressure – water pressure must remain at minimum of 25 psi
	b. Incorrect injector size	b. Replace injector with correct size for the application
	c. Restricted drain line	c. Check drain line for restrictions or debris and clean
11. Excessive water in regenerant tank	a. Improper program settings	a. Check refill setting
	b. Plugged injector	b. Remove injector and clean or replace
	c. Drive cap assembly not tightened in properly	c. Re-tighten the drive cap assembly
	d. Damaged seal/ stack assembly	d. Replace seal/ stack
	e. Restricted or kinked drain line	e. Check drain line for restrictions or debris and or un-kink drain line
	f. Plugged backwash flow controller	f. Remove backwash flow controller and clean or replace
	g. Missing refill flow controller	g. Replace refill flow controller
12. Control valve fails to draw in regenerant	a. Injector is plugged	a. Remove injector and clean or replace
	b. Faulty regenerant piston	b. Replace regenerant piston
	c. Regenerant line connection leak	c. Inspect regenerant line for air leak
	d. Drain line restriction or debris cause excess back pressure	d. Inspect drain line and clean to correct restriction
	e. Drain line too long or too high	e. Shorten length and or height
	f. Low water pressure	f. Check incoming water pressure – water pressure must remain at minimum of 25 psi
13. Water running to drain	a. Power outage during regeneration	a. Upon power being restored control will finish the remaining regeneration time. Reset time of day.
	b. Damaged seal/ stack assembly	b. Replace seal/ stack assembly
	c. Piston assembly failure	c. Replace piston assembly
	d. Drive cap assembly not tightened in properly	d. Re-tighten the drive cap assembly

Troubleshooting- Controller Error Codes

Problem	Possible Cause	Solution
14. E1, Err – 1001, Err – 101 = Control unable to sense motor movement	a. Motor not inserted full to engage pinion, motor wires broken or disconnected	a. Disconnect power, make sure motor is fully engaged, check for broken wires, make sure two pin connector on motor is connected to the two pin connection on the PC Board labeled MOTOR. Press NEXT and REGEN buttons for 3 seconds to resynchronize software with piston position or disconnect power supply from PC Board for 5 seconds and then reconnect.
	b. PC Board not properly snapped into drive bracket	b. Properly snap PC Board into drive bracket and then Press NEXT and REGEN buttons for 3 seconds to resynchronize software with piston position or disconnect power supply from PC Board for 5 seconds and then reconnect.
	c. Missing reduction gears	c. Replace missing gears
15. E2, Err – 1002, Err – 102 = Control valve motor ran too short and was unable to find the next cycle position and stalled	a. Foreign material is lodged in control valve	a. Open up control valve and pull out piston assembly and seal/ stack assembly for inspection. Press NEXT and REGEN buttons for 3 seconds to resynchronize software with piston position or disconnect power supply from PC Board for 5 seconds and then reconnect.
	b. Mechanical binding	b. Check piston and seal/ stack assembly, check reduction gears, check drive bracket and main drive gear interface. Press NEXT and REGEN buttons for 3 seconds to resynchronize software with piston position or disconnect power supply from PC Board for 5 seconds and then reconnect.
	c. Main drive gear too tight	c. Loosen main drive gear. Press NEXT and REGEN buttons for 3 seconds to resynchronize software with piston position or disconnect power supply from PC Board for 5 seconds and then reconnect.
	d. Improper voltage being delivered to PC Board	d. Verify that proper voltage is being supplied. Press NEXT and REGEN buttons for 3 seconds to resynchronize software with piston position or disconnect power supply from PC Board for 5 seconds and then reconnect.
16. E3, Err – 1003, Err – 103 = Control valve motor ran too long and was unable to find the next cycle position	a. Motor failure during a regeneration	a. Check motor connections then Press NEXT and REGEN buttons for 3 seconds to resynchronize software with piston position or disconnect power supply from PC Board for 5 seconds and then reconnect.
	b. Foreign matter built up on piston and stack assemblies creating friction and drag enough to time out motor	b. Replace piston and stack assemblies. Press NEXT and REGEN buttons for 3 seconds to resynchronize software with piston position or disconnect power supply from PC Board for 5 seconds and then reconnect.
	c. Drive bracket not snapped in properly and out enough that reduction gears and drive gear do not interface	c. Snap drive bracket in properly then Press NEXT and REGEN buttons for 3 seconds to resynchronize software with piston position or disconnect power supply from PC Board for 5 seconds and then reconnect.
17. Err – 1004, Err – 104 = Control valve motor ran too long and timed out trying to reach home position	a. Drive bracket not snapped in properly and out enough that reduction gears and drive gear do not interface	a. Snap drive bracket in properly then Press NEXT and REGEN buttons for 3 seconds to resynchronize software with piston position or disconnect power supply from PC Board for 5 seconds and then reconnect.

Troubleshooting- Controller Error Codes

Problem	Possible Cause	Solution
<p>18. Err -1006, Err – 106, Err - 116 = MAV/ SEPS/ NHBP/ AUX MAV valve motor ran too long and unable to find the proper park position</p> <p>Motorized Alternating Valve = MAV</p> <p>Separate Source = SEPS</p> <p>No Hard Water Bypass = NHBP</p> <p>Auxiliary MAV = AUX MAV</p>	<p>a. Control valve programmed for ALT A or b, nHbP, SEPS, or AUX MAV with out having a MAV or NHBP valve attached to operate that function</p>	<p>a. Press NEXT and REGEN buttons for 3 seconds to resynchronize software with piston position or disconnect power supply from PC Board for 5 seconds and then reconnect. Then re-program valve to proper setting.</p>
	<p>b. MAV/ NHBP motor wire not connected to PC Board</p>	<p>b. Connect MAV/ NHBP motor to PC Board two pin connection labeled DRIVE. Press NEXT and REGEN buttons for 3 seconds to resynchronize software with piston position or disconnect power supply from PC Board for 5 seconds and then reconnect.</p>
	<p>c. MAV/ NHBP motor not fully engaged with reduction gears</p>	<p>c. Properly insert motor into casing, do not force into casing Press NEXT and REGEN buttons for 3 seconds to resynchronize software with piston position or disconnect power supply from PC Board for 5 seconds and then reconnect.</p>
	<p>d. Foreign matter built up on piston and stack assemblies creating friction and drag enough to time out motor</p>	<p>d. Replace piston and stack assemblies. Press NEXT and REGEN buttons for 3 seconds to resynchronize software with piston position or disconnect power supply from PC Board for 5 seconds and then reconnect.</p>
<p>19. Err – 1007, Err – 107, Err - 117 = MAV/ SEPS/ NHBP/ AUX MAV valve motor ran too short (stalled) while looking for proper park position</p> <p>Motorized Alternating Valve = MAV</p> <p>Separate Source = SEPS</p> <p>No Hard Water Bypass = NHBP</p> <p>Auxiliary MAV = AUX MAV</p>	<p>a. Foreign material is lodged in MAV/ NHBP valve</p>	<p>a. Open up MAV/ NHBP valve and check piston and seal/ stack assembly for foreign material. Press NEXT and REGEN buttons for 3 seconds to resynchronize software with piston position or disconnect power supply from PC Board for 5 seconds and then reconnect.</p>
	<p>b. Mechanical binding</p>	<p>b. Check piston and seal/ stack assembly, check reduction gears, drive gear interface, and check MAV/ NHBP black drive pinion on motor for being jammed into motor body. Press NEXT and REGEN buttons for 3 seconds to resynchronize software with piston position or disconnect power supply from PC Board for 5 seconds and then reconnect.</p>

Water Softener Flow Diagrams

CWS-150 Control Valve Cycle Positions

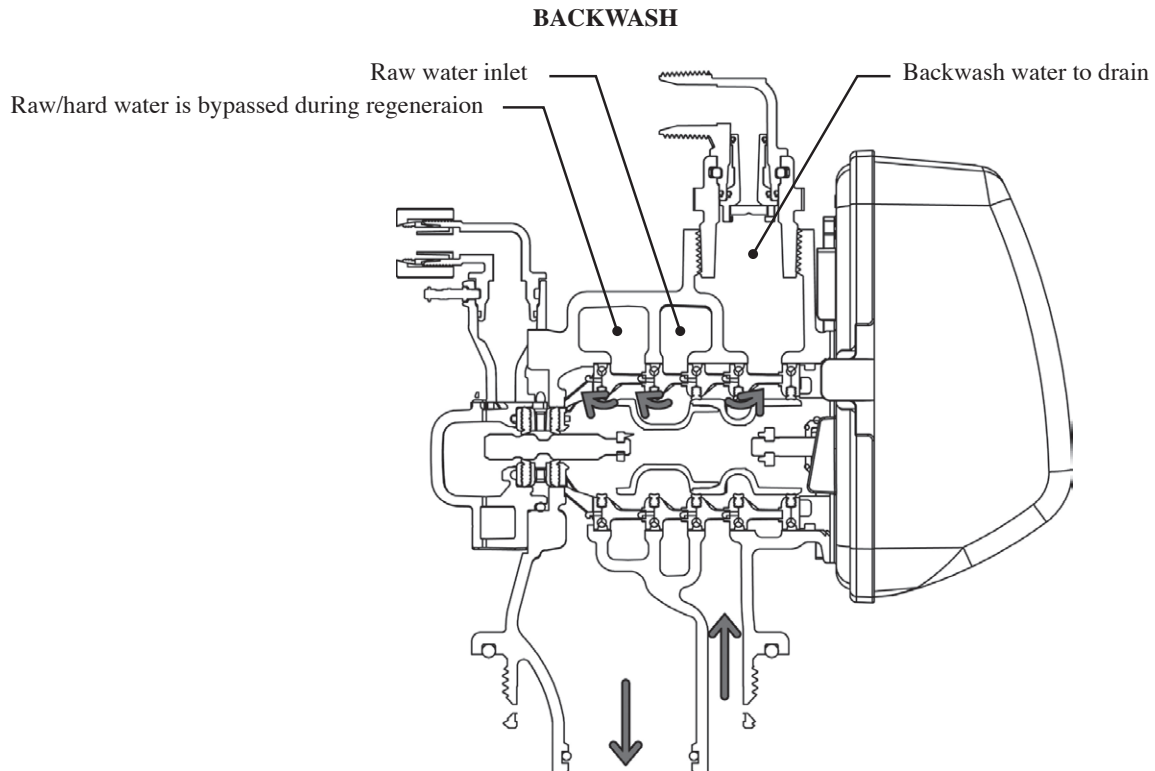
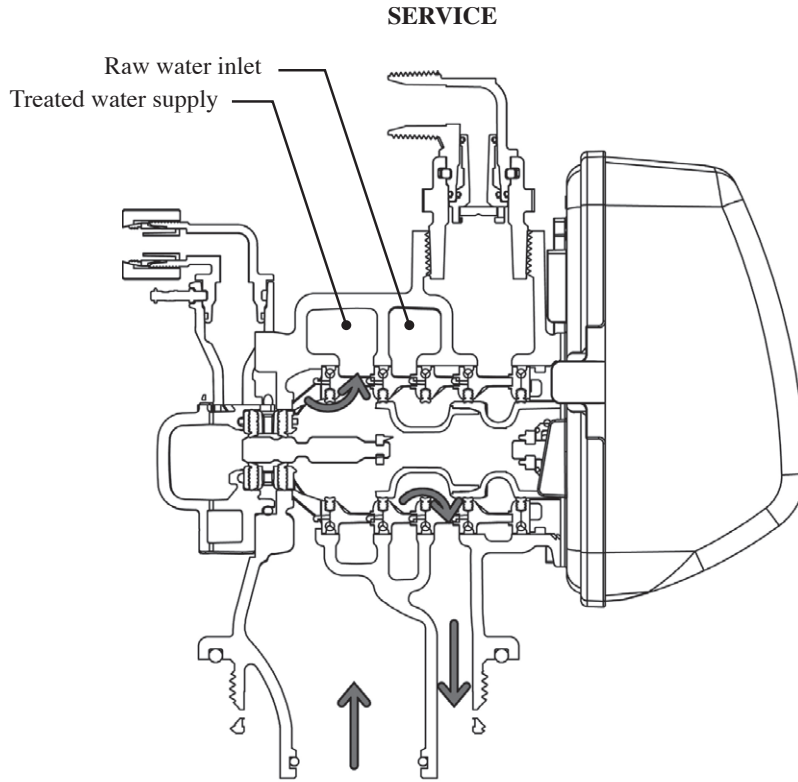

Water Softener Flow Diagrams

CWS-150 Control Valve Cycle Positions

DOWNFLOW BRINE

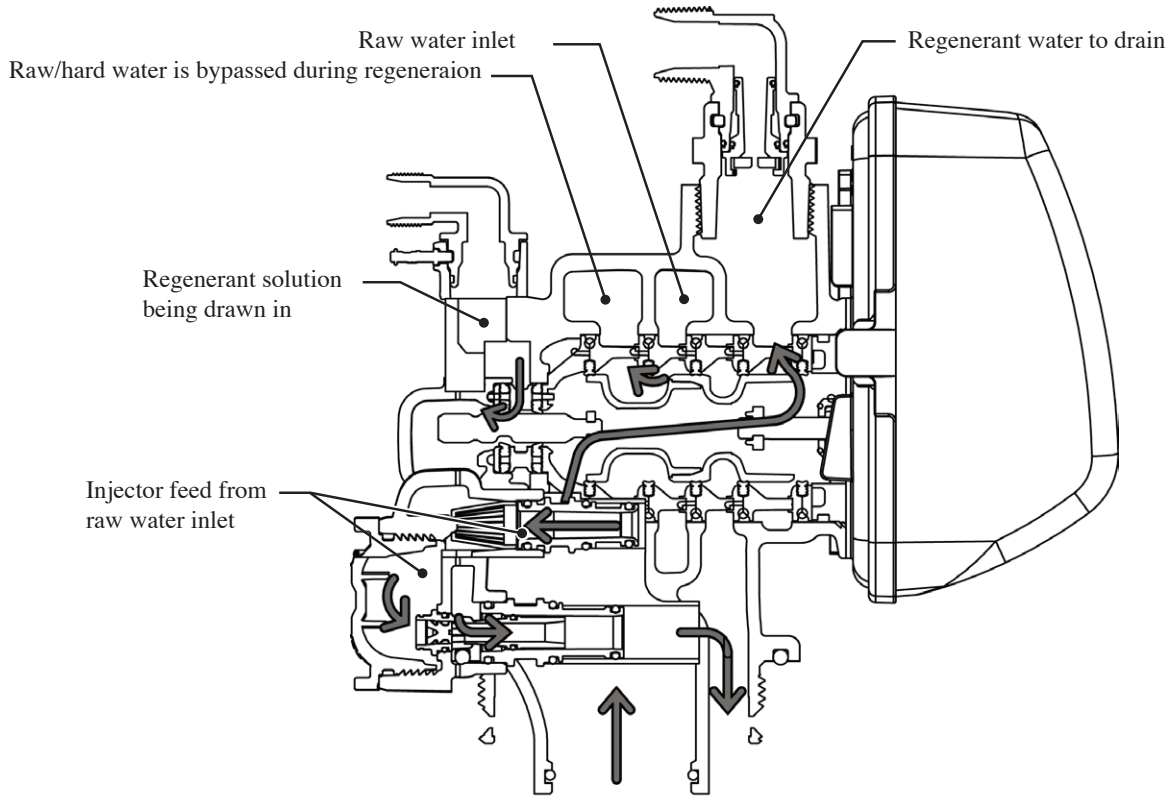

UPFLOW BRINE

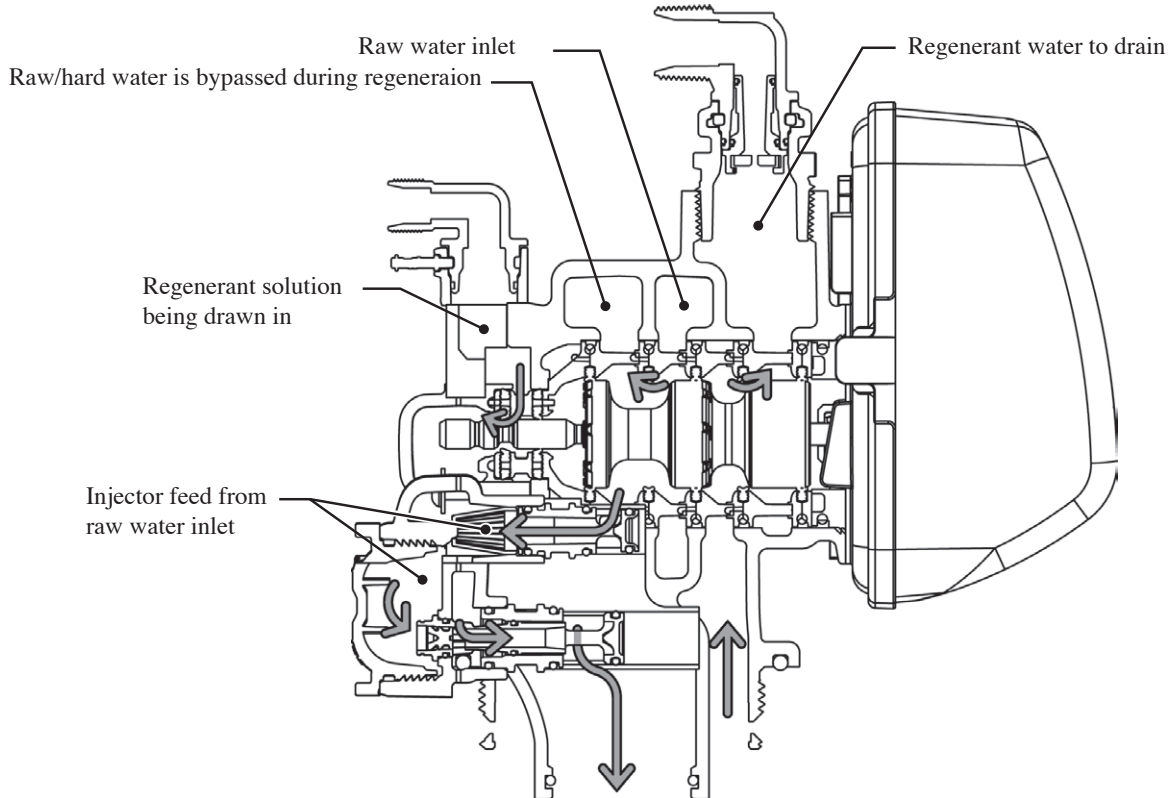

Water Softener Flow Diagrams

CWS-150 Control Valve Cycle Positions

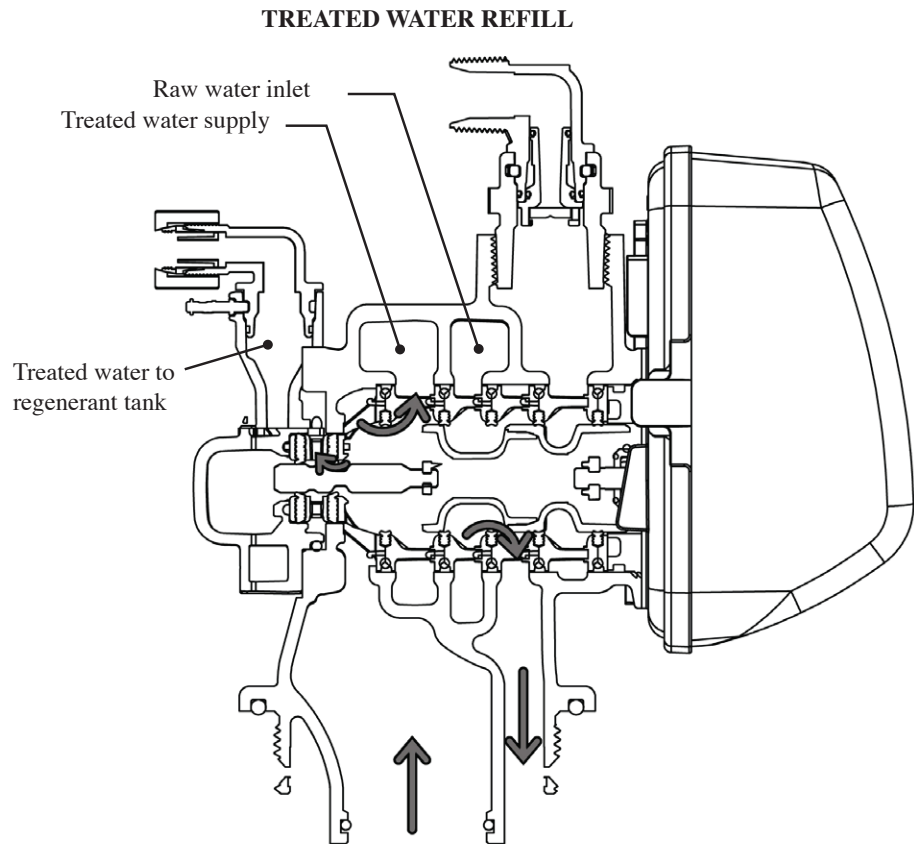
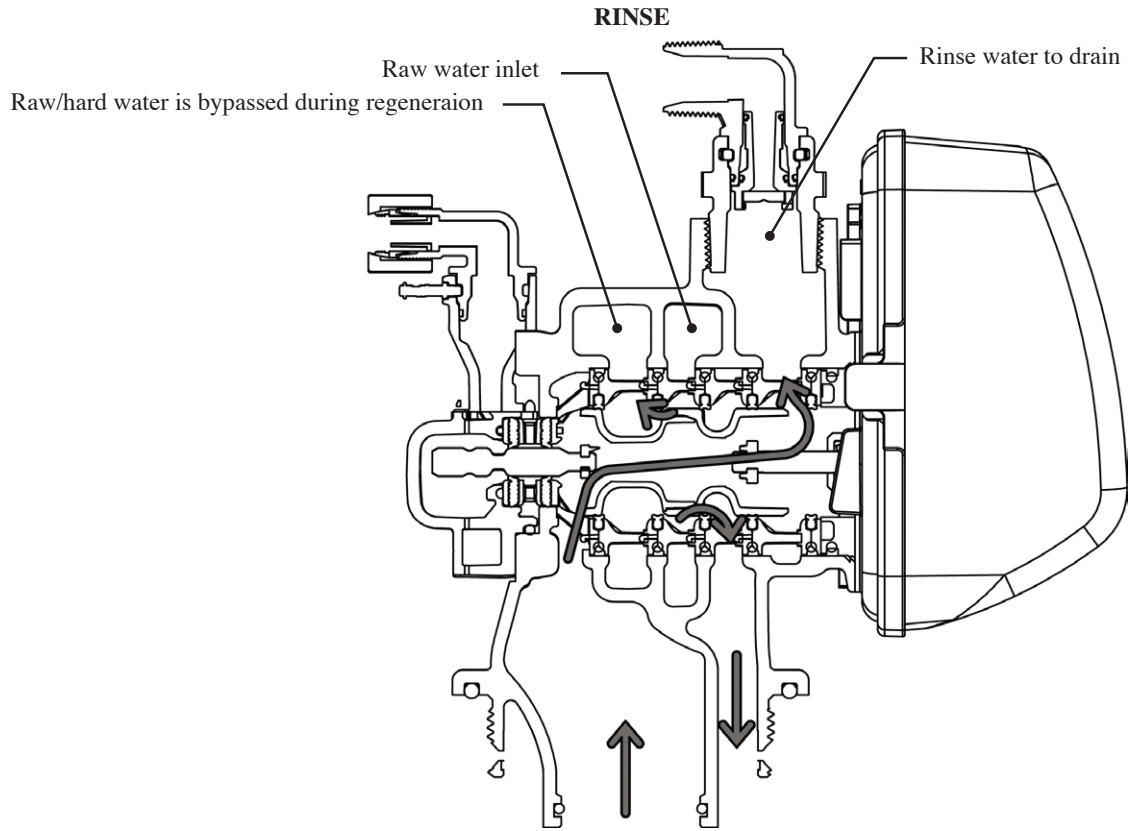

Injector Flow Data and Draw Rates

Violet, Legacy No. V3010-15B
Metric Units

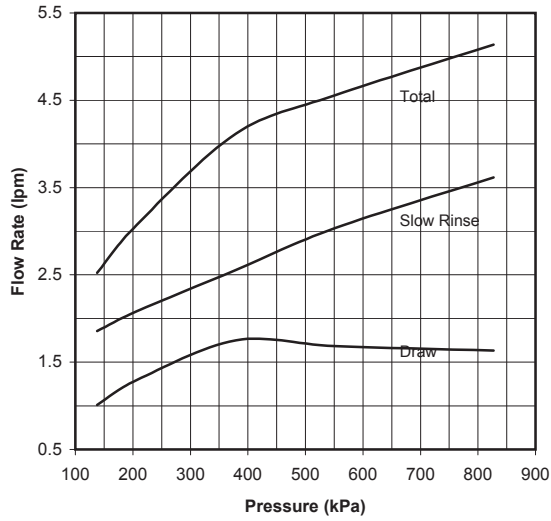

Violet, Legacy No. V3010-15B
US Units

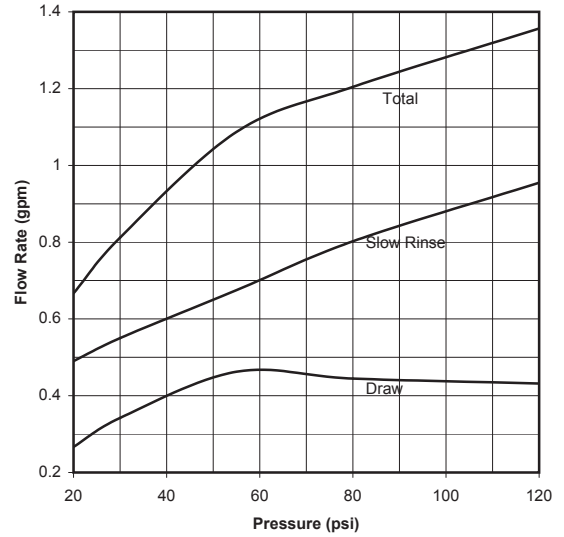

Red, Legacy No. V3010-15C
Metric Units

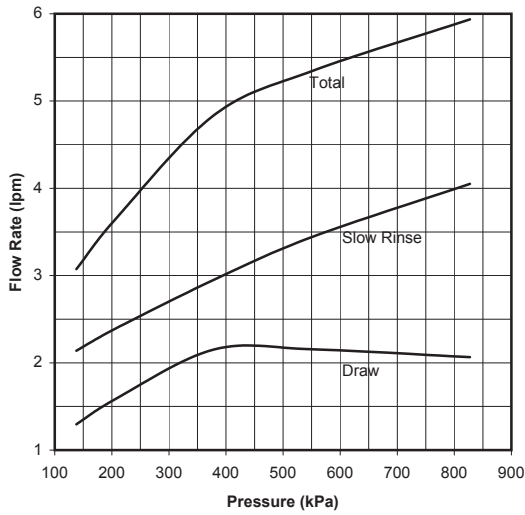

Red, Legacy No. V3010-15C
US Units

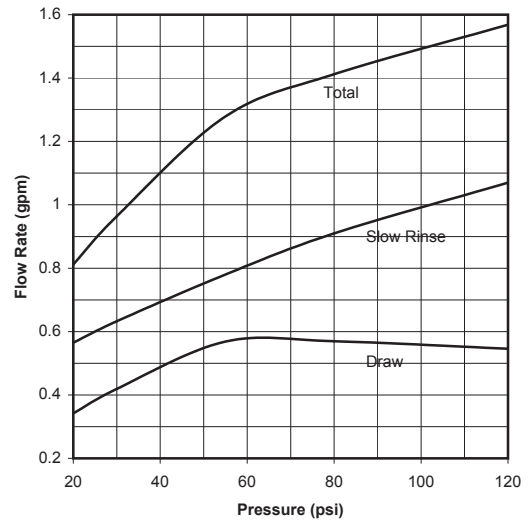

Injector Flow Data and Draw Rates

White, Legacy No. V3010-15D
Metric Units

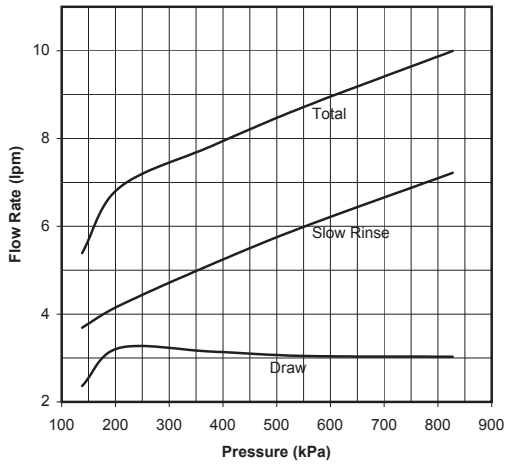

White, Legacy No. V3010-15D
US Units

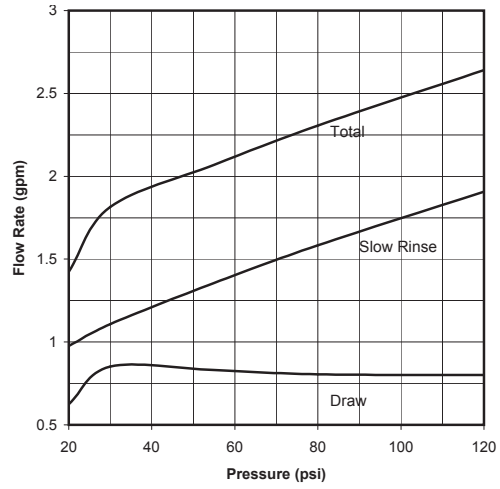

Blue, Legacy No. V3010-15E
Metric Units

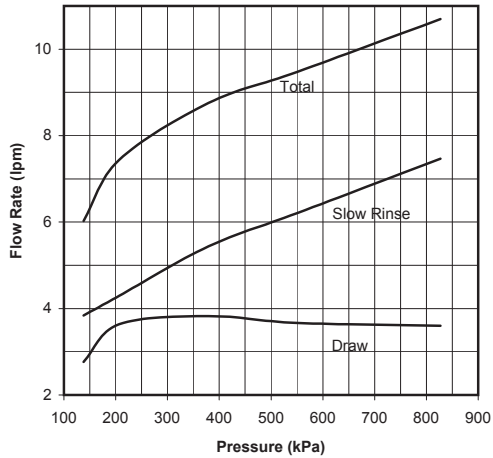

Blue, Legacy No. V3010-15E
US Units

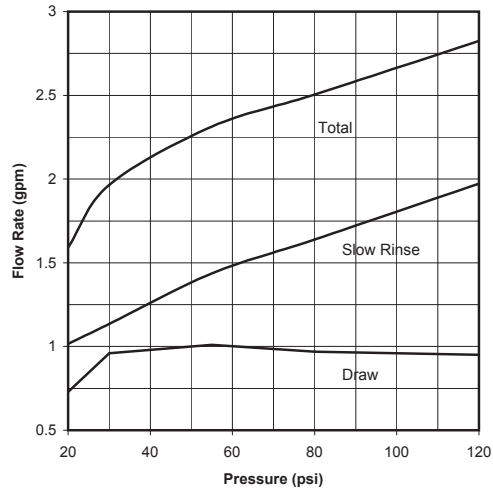

Yellow, Legacy No. V3010-15F
Metric Units

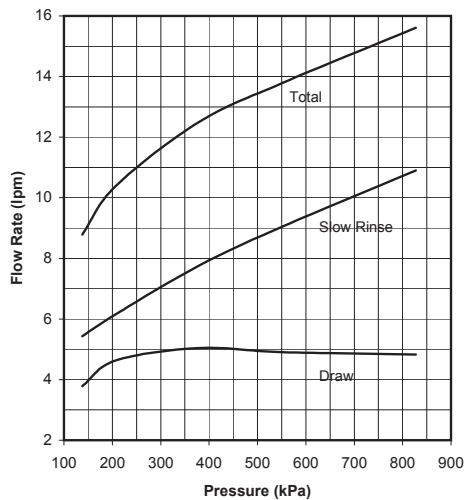

Yellow, Legacy No. V3010-15F
US Units

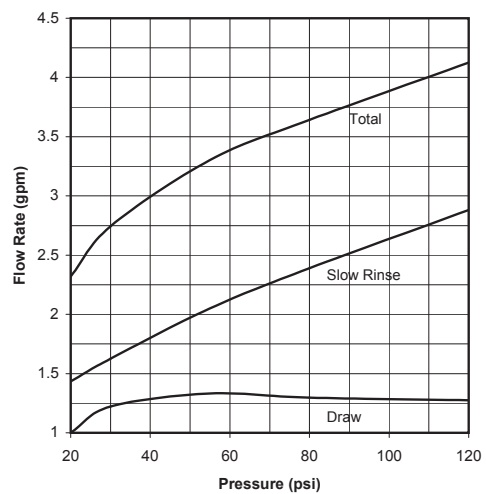

Injector Flow Data and Draw Rates

Green Legacy No. V3010-15G
Metric Units

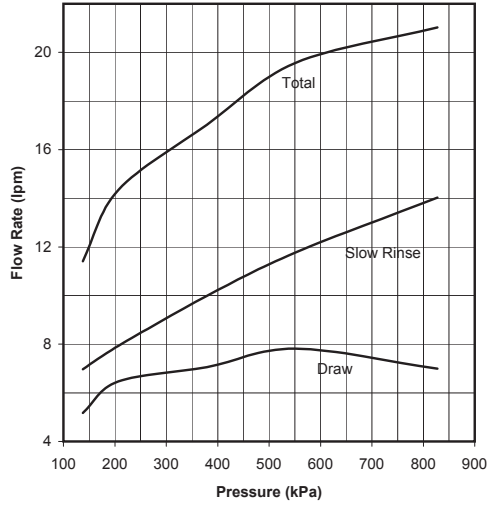

Green, Legacy No. V3010-15G
US Units

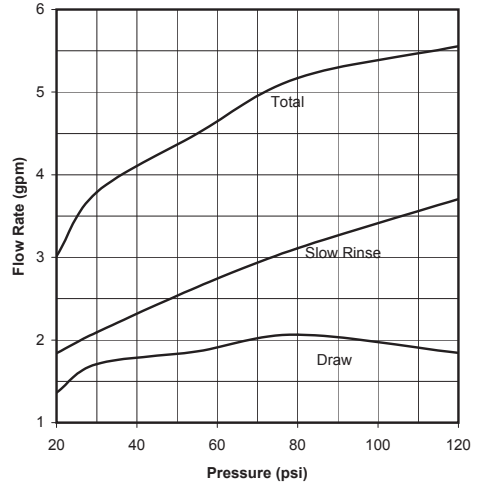

Orange Legacy No. V3010-15H
Metric Units

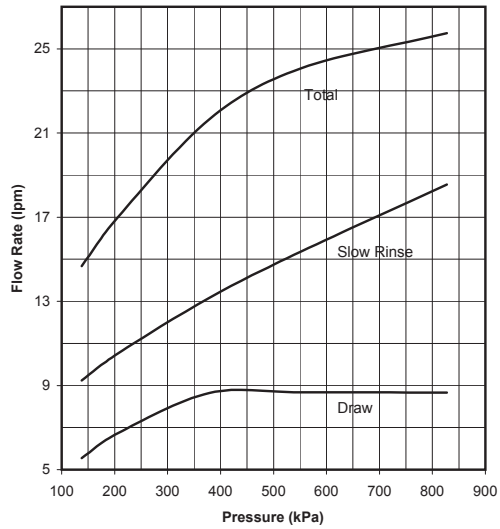

Orange Legacy No. V3010-15H
US Units

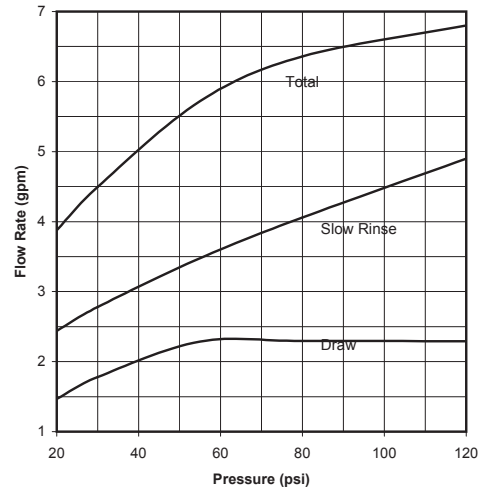

Injector Nozzle and Throat Chart

CWS-150 Injectors					
Item No.	Legacy No.	Description	Nozzle Colorw	Downflow Typical Tank Diameter ¹	Quantity
1	V3010-15B	CWS-150 Injector Asy B	Violet	12"	1
	V3010-15C	CWS-150 Injector Asy C	Red	13"	
	V3010-15D	CWS-150 Injector Asy D	White	14"	
	V3010-15E	CWS-150 Injector Asy E	Blue	16"	
	V3010-15F	CWS-150 Injector Asy F	Yellow	18"	
	V3010-15G	CWS-150 Injector Asy G	Green	21"	
	V3010-15H	CWS-150 Injector Asy H	Orange	24"	
2	V3010-15Z	CWS-150 Injector Plug		NA	

V3010-15B through V3010-15H injectors include one V3416 o-ring 012 (lower) and one V3171 o-ring 013 (upper).

For upflow brine application downsize your injector by two tank sizes minimum and refer to the injector graphs for verifying proper selection.

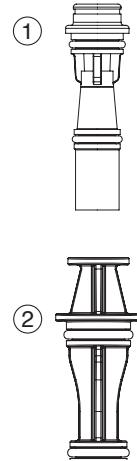

Motorized Alternating Valve Piston Style Applications

OPERATING PRESSURES: 20 PSI MINIMUM / 125 PSI MAXIMUM

OPERATING TEMPERATURES: 40°F MINIMUM / 110°F MAXIMUM

Service or Installation of Motor.

Do not lubricate the motor or the gears. To install the motor, move the spring clip loop to the right and hold. Gently turn the motor while inserting so that the gear on the motor meshes with the gears under the drive gear cover. If the motor will not easily engage with the drive gears when reinstalling, lift and slightly rotate the motor before reinserting. Release the spring clip loop and continue to rotate the motor until the wires are horizontal and the motor housing engages the small plastic bulge inside the drive bracket motor retainer. Reconnect the motor plug to the two-pronged jack on the board labeled drive.

If the control valve manual does not include instructions for setting up the software for No Hard Water Bypasses (NHWB), Separate Source (SEPS), or Twin Tank Operation (ALT A and ALT b), please contact your local equipment supplier for current copies of installation instructions.

Up to 2 additional cables can be brought through the back plate. Locate the round strain relief knock-out on the inside of the back plate. Use a punch and hammer to remove the knock-out. One or both tabs at the bottom of the strain relief feature may be broken out with a needle-nose pliers. The additional cables may be brought through the knock-out hole, and connected to the PC board. After the cables are connected to the PC board, weave the cables through the strain relief feature, and then use 68104988 Strain Relief Cover Kit to cover the cables in the strain relief. To help prevent damage to the cables, allow nearby solder joints to cool, or solvent cement joints to cure.

- For twin tank operation, the 8' interconnect cable must be threaded through the back plates and connected to the three pin connector labeled COMM CABLE on both the ALT A and

ALT b control valves. The 8' interconnect cable is not used for No Hard Water Bypass (NHWB) or Separate Source (SEPS) operation.

NOTICE It is possible to use the Motorized Alternating Valve on controls with individual meters with some International or Custom PC Boards. When using the Motorized Alternating Valve with two meters, it is necessary to disconnect or cut the left wire on the interconnect cable. This is the wire closest to the center cut out on the PC Board.

- The 8' alternator valve motor cable must be threaded through the back plate and connected to the two pin connector labeled MAV on the control valve board (for twin tank operation connect to the unit set as ALT A).
- The 15' water meter cable must be threaded through the back plate and connected to the three pin connection labeled METER on the control valve board.

NOTICE A meter must be used for twin tank operation, meters are recommended but not required for NHWB or SEPS operation. If using the Motorized Alternating Valve with a meter on each control, it is necessary to connect each meter to the PC Board.

- The 15' AC Adapter or power cable must be thread through the back plate of all control valves. The AC adapter should be installed to a properly grounded (not switched) outlet.

No Hard Water Bypass:

The MAV will be driven closed before the first regeneration cycle that is not FILL or SOFTENING or FILTERING, and be driven open after the last regeneration cycle that is not FILL. If the control valve enters into an error state during regeneration mode, the MAV will remain in its current state until the error is corrected and reset.

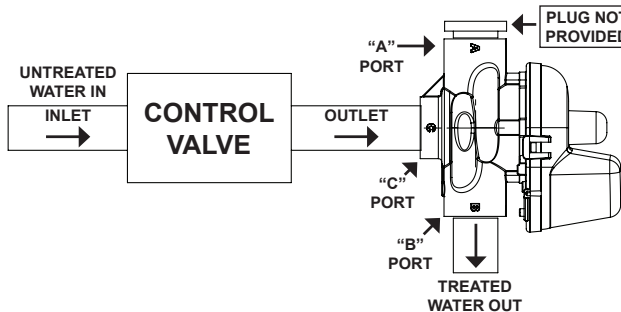

⚠ WARNING

No Hard Water Bypass installation prevents water from entering the downstream plumbing. If a downstream plumbing device or local code requires an uninterrupted water supply, design the installations to accommodate.

Separate Source Regeneration:

The MAV will be driven closed (i.e. let water flow from A port to C port) before the first regeneration cycle, and be driven open (i.e. let water flow from B port to C port) after the last regeneration cycle. If the control valve enters into an error state during regeneration mode, the MAV will remain in its current state until the error is corrected and reset.

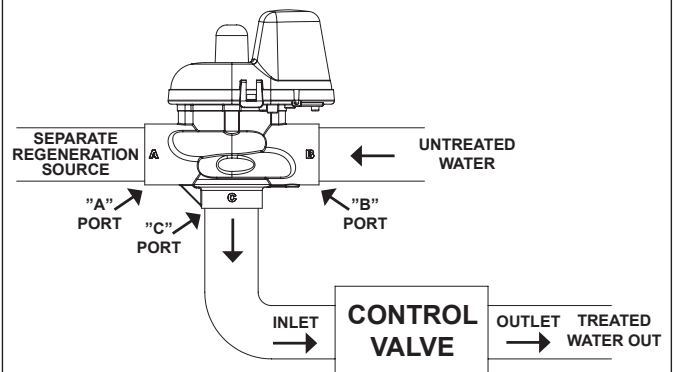

NOTICE If there is a treated water demand during regeneration, separate source water will be used.

Motorized Alternating Valve Piston Style Applications

Service or Installation of Motor.

If the control valve manual does not include instructions for setting up ALTA and ALTb software, please contact your local equipment supplier for current copies of installation instructions. If the control valve is in an error state during regeneration mode, the MAV will close the B port and keep open the A port until the error is corrected and reset.

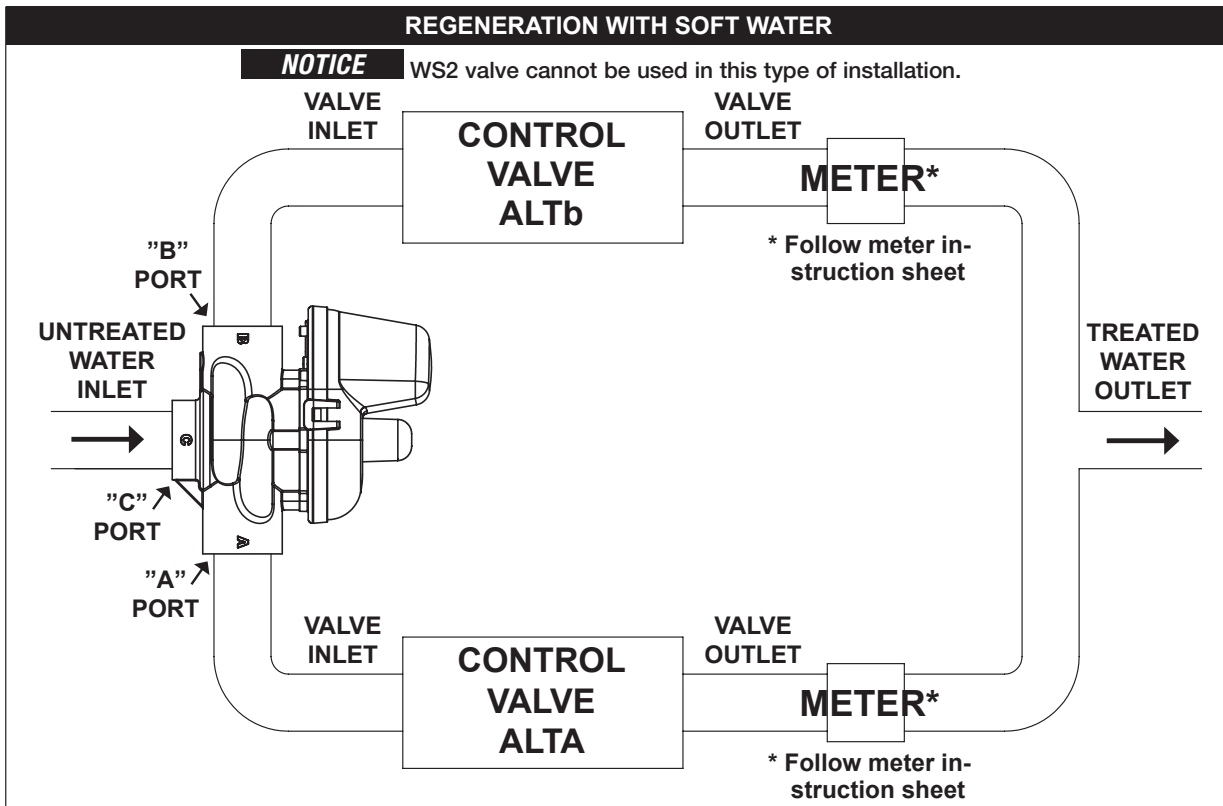
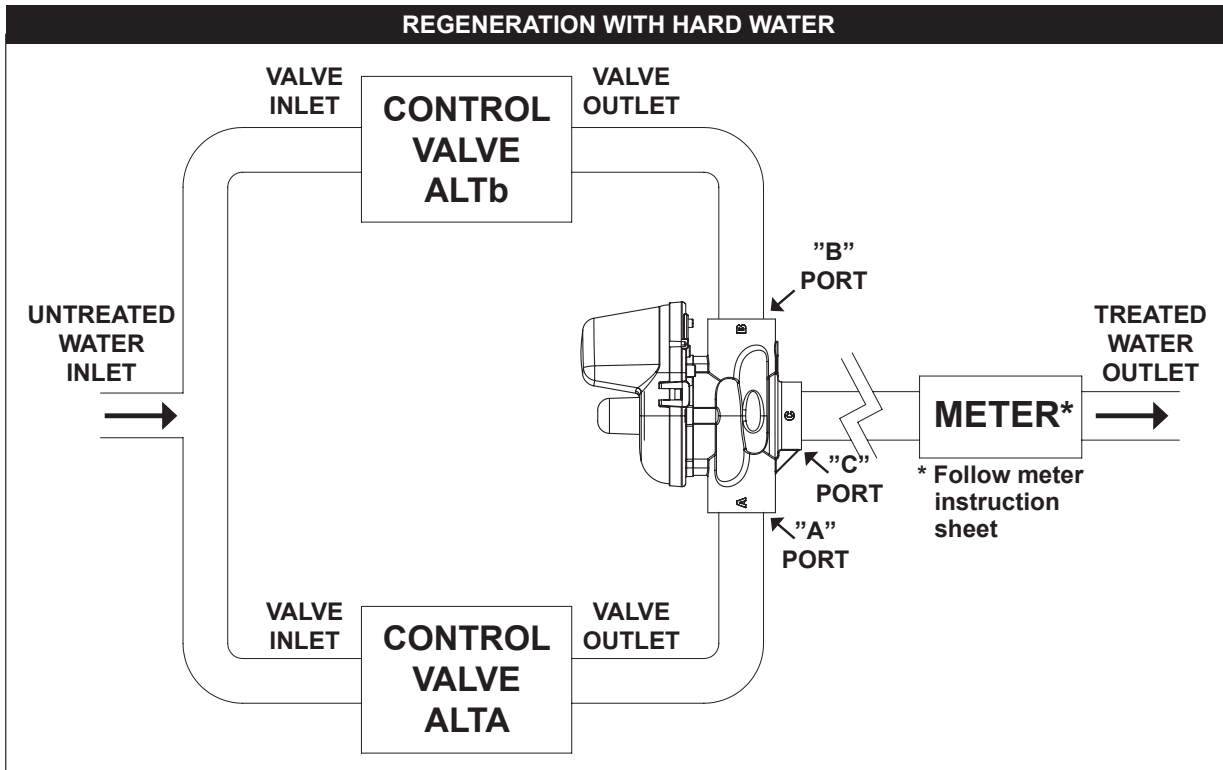

Motorized Alternating Valve Piston Style Applications

MAV ordering information:

Order No.	Description	Quantity
68108938	WST-PCL-V3071 WCS MOTORIZED ALTERNATOR VLV 1.5"	1

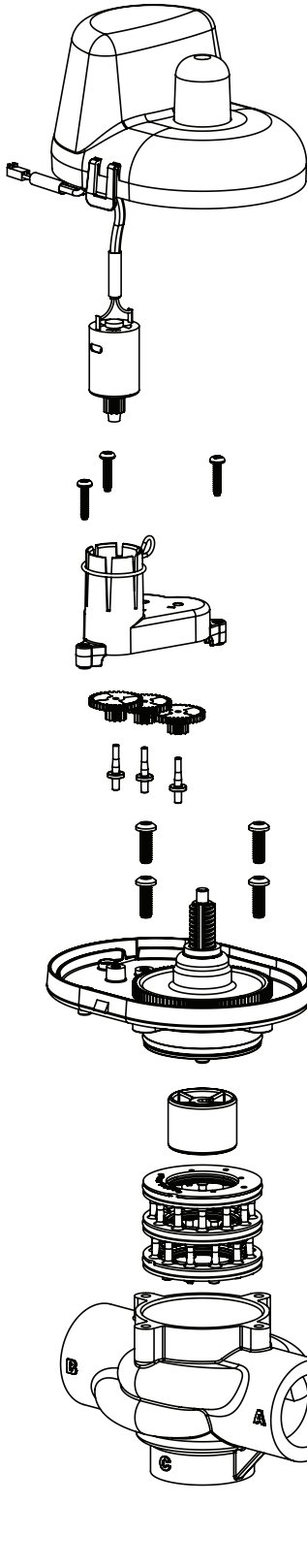

•Operating Pressures:
20 PSI Minimum / 125 PSI Maximum
•Operating Temperatures:
40°F Minimum / 110°F Maximum

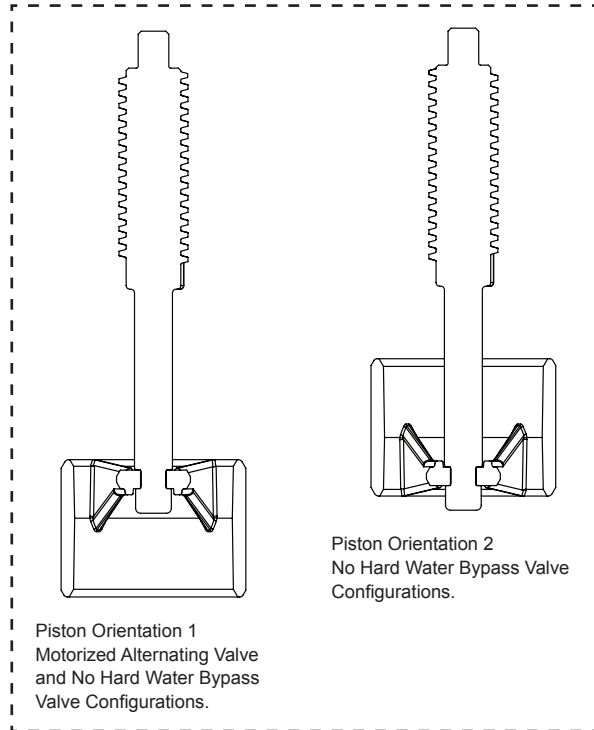

WATER SOFTENERS/FILTERS Limited Warranty:

The Company warrants each fiberglass tank 13 inches in diameter and smaller to be free from defects in material and workmanship under normal usage for a period of ten years from the date of original shipment.

The Company warrants each fiberglass tank 14 inches in diameter and larger to be free from defects in material and workmanship under normal usage for a period of five years from the date of original shipment.

The Company warrants any size Salt Tank (Brine Tank) to be free from defects in material and workmanship under normal usage for a period of five years from the date of original shipment.

The Company warrants each Control valve to be free from defects in material and workmanship under normal usage for a period of five years from the date of original shipment.

The Company warrants diaphragm valve nests and related controls to be free from defects in material and workmanship under normal usage for a period of one year from the date of original shipment.

The Company warrants all other components to be free from defects in material and workmanship under normal usage for a period of one year from the date of original shipment.

Water softener resins subjected to iron, manganese and chlorine levels greater than 1ppm are expressly not covered by this warranty. Manganese greensand media and expendable media such as activated carbon, Filox[®], Micro-Z[®] and neutralizing media are also not covered by this warranty. In the event of a covered defect within the warranty period, the Company will, at its option, replace or recondition the product without charge.

Disclaimer of Warranty. THE WARRANTY SET FORTH HEREIN IS GIVEN EXPRESSLY AND IS THE ONLY WARRANTY GIVEN BY THE COMPANY WITH RESPECT TO THE PRODUCT. THE COMPANY MAKES NO OTHER WARRANTIES, EXPRESS OR IMPLIED. THE COMPANY HEREBY SPECIFICALLY DISCLAIMS ALL OTHER WARRANTIES, EXPRESS OR IMPLIED, INCLUDING BUT NOT LIMITED TO THE IMPLIED WARRANTIES OF MERCHANTABILITY AND FITNESS FOR A PARTICULAR PURPOSE.

Limitation of Liability. The remedy described in the first paragraph of this warranty shall constitute the sole and exclusive remedy for breach of warranty, and the Company shall not be responsible for any incidental, special or consequential damages, including without limitation, lost profits or the cost of repairing or replacing other property which is damaged if this product does not work properly, other costs resulting from labor charges, delays, vandalism, negligence, fouling caused by foreign material, damage from adverse water conditions, chemical, or any other circumstances over which the Company has no control. This warranty shall be invalidated by any abuse, misuse, misapplication, improper installation or improper maintenance or alteration of the product

Some States do not allow limitations on how long an implied warranty lasts, and some States do not allow the exclusion or limitation of incidental or consequential damages. Therefore the above limitations may not apply to you. This Limited Warranty gives you specific legal rights, and you may have other rights that vary from State to State. You should consult applicable state laws to determine your rights. **SO FAR AS IS CONSISTENT WITH APPLICABLE STATE LAW, ANY IMPLIED WARRANTIES THAT MAY NOT BE DISCLAIMED, INCLUDING THE IMPLIED WARRANTIES OF MERCHANTABILITY AND FITNESS FOR A PARTICULAR PURPOSE, ARE LIMITED IN DURATION TO ONE YEAR FROM THE DATE OF ORIGINAL SHIPMENT.**



USA: T: (800) 659-8400 • N. Andover, MA 01845 • Watts.com

Canada: T: (888) 208-8927 • Burlington, ON M5J3G6 • Watts.ca

Latin America: T: (52) 55-4122-0138 • Watts.com