

Installation, Operation, and Maintenance Manual

PWSCAB Series

Residential Cabinet Water Softener

⚠ WARNING



Read this Manual **BEFORE** using this equipment.

Failure to read and follow all safety and use information can result in death, serious personal injury, property damage, or damage to the equipment.



Keep this Manual for future reference.

⚠ WARNING

You are required to consult the local building and plumbing codes prior to installation. If the information in this manual is not consistent with local building or plumbing codes, the local codes should be followed. Inquire with governing authorities for additional local requirements.

⚠ WARNING

Need for Periodic Inspection/Maintenance: This product must be tested periodically in compliance with local codes, but at least once per year or more as service conditions warrant. All products must be retested once maintenance has been performed. Corrosive water conditions, and/or unauthorized adjustments or repair could render the product ineffective for the service intended. Regular checking and cleaning of the product's internal components helps assure maximum life and proper product function.

⚠ WARNING

Do not use with water that is microbiologically unsafe or of unknown quality. Adequate disinfection required before and after the system.

NOTICE

Hydrocarbons such as Kerosene, Benzene, and Gasoline may damage products that contain O-rings or plastic components. Exposure to such hydrocarbons may cause the products to leak. Do not use the product(s) contained in this document on water supplies that contain Hydrocarbons such as Kerosene, Benzene, Gasoline, and others.

Watts is not responsible failure of product due to connectivity issues, power issues, or improper installation.



PWSCAB Series Softener

Contents

System Specification	2
System Dimensions	2
Control Valve Functions and Operation Cycles	3
General Installation Guidelines	4
Installation Preview	5
Preinstallation Considerations	6
Installation Instructions	6
System Programming	10
Control Programming	12
General Operation	13
Clock Programming	14
Sanitizing the System	14
System Components	15
Drawings and Part Numbers	18
Troubleshooting	24

System Specification

Call customer service if you need assistance with technical details.

MODEL NO.	ORDERING CODE	CAPACITY (MAX.)	PIPE SIZE (IN.)	MINERAL TANK			CABINET SIZE (W x D x H)	SALT FILL (LB)	FLOW RATE & PRESSURE			SHIP WT. ((LB)
				TANK SIZE	RESIN FT ³	GRAVEL (LB)			SERVICE (GPM)	DROP (PSI)	BKW (GPM)	
PWSCAB45K	7101109	45,000	1.0"	12" x 35"	1.5	20	13.8" x 24.6" x 44.6"	208	12 - 16	15 - 25	2.7	130

System Dimensions

MODEL NO.	ORDERING CODE	OVERALL WIDTH		INLET		OUTLET		OVERALL HEIGHT		OVERALL DEPTH	
		in.	mm	in.	mm	in.	mm	in.	mm	in.	mm
PWSCAB45K	7101109	13.8	348	37.2	945	37.2	945	44.6	1130	24.6	625

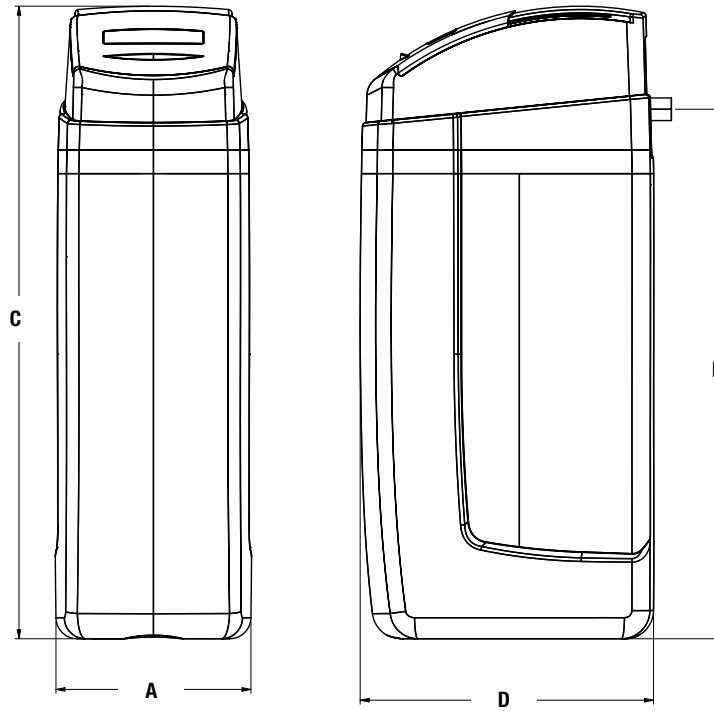

Cabinet Tank

Control Valve Functions and Operation Cycles

This glass-filled Noryl® fully automatic control valve is designed as the primary control center to direct and regulate all cycles of a water softener. The control valve can be set to regenerate on demand (consumption of a predetermined amount of water) and/or as a time clock (passage of a particular number of days).

The control valve is compatible with a variety of regenerants and resin cleaners. The control valve is capable of routing the flow of water in the necessary paths to regenerate or backwash water treatment systems. The injector regulates the flow of brine or other regenerants. The control valve regulates the flow rates for backwashing, rinsing, and the replenishing of treated water into a regenerant tank.

The control valve is designed to deliver high service (27 gpm at 15 psig) and backwash (27 gpm at 25 psig) flow rates when the bypass has straight fittings. The control valve uses no traditional fasteners such as screws; instead, clips, threaded caps and nuts, and snap type latches are used. Caps and nuts only need to be firmly hand tightened because radial seals are used. Tools required to service the valve include one small blade screwdriver, one large blade screwdriver, pliers, and a pair of hands. A plastic wrench is available which eliminates the need for screwdrivers and pliers. Disassembly for servicing takes much less time than comparable products currently on the market.

The transformer power pack comes with a 15-foot power cord and is designed for use with the control valve. The transformer power pack is for dry location use only. The control valve remembers all settings for 2 hours if the power goes out. After 2 hours the only item that needs to be reset is the time of day; all other values are permanently stored in the nonvolatile memory. The control valve does not need batteries.

When the control valve is used as a down flow softener, two backwashes always occur. The softener starts regenerant prefill before regeneration; the prefill starts 2 hours before the regeneration time set. During the 2-hour period in which the brine is being made, treated (softened) water is still available. For example: regeneration time means 2:00 a.m., prefill option selected, downflow softener. Fill occurs at 12:00 a.m.; start of backwash cycle occurs at 2:00 a.m.

The softener adjusts the backwash and rinse cycles automatically increase with increasing salt dosage. Backwashes can be set to NORMAL or LONGER. The option selected applies to all backwashes.

Regeneration Steps and Purpose

Brine fill – Brine tank is filled to dissolve salt for next regeneration.

Backwash – Flow through the resin bed is reversed. Water flows upward, expanding, and agitating the resin bed.

Brine in – Brine is educted from the brine tank and passes through the resin bed in a downward flow, thus removing calcium and magnesium that has accumulated on the resin beads, and is subsequently flushed to drain.

Backwash – A second backwash is performed.

Rinse – The resin is now flushed downward at a set flow rate. This resettles the bed and rinses out any remaining brine left in the resin bed.

Service – Softener goes back into service and is ready to soften water.

Exchange Capacity Data

20,000 grain approx. per cubic feet

6 pounds salt-sodium chloride

25,000 grain approx. per cubic feet

8 pounds salt-sodium chloride

30,000 grain approx. per cubic feet

15 pounds salt-sodium chloride

NOTICE

To convert parts per million (PPM) or milligrams per liter (mpl) to grains divide by 17.1.

Example: Water hardness of 250 PPM

(250 PPM divided by 17.1 PPM/gr) equals 14.6 gr

It is recommended that a good grade of solar or pellet salt be used.

One gallon of water dissolves approximately 3.0 pounds of salt.

One gallon of saturated brine weighs 10.74 pounds.

▲ IMPORTANT SAFEGUARDS

General Installation Guidelines

This water softener's control valve conforms to UL/CE Standards. Generic valves were tested and certified for compliance as verified by the agency listing. This water softening system is to be used only for potable water. Inspect the water softening system for carrier shortage or shipping damage before beginning installation.

Operating Parameters

- Operating ambient temperature: 40°F to 110°F (5°C to 43°C).
- Operating water temperature: 40°F to 110°F (5°C to 43°C).
- Operating water pressure range: 25 to 120 psi (1.7 to 8.27 bar).

Installation Parameters

All plumbing should be done in accordance with local plumbing codes.

- Do not use pipe dope or other sealants on threads. Use PTFE tape on the threaded inlet, outlet, and drain fittings. PTFE tape is not necessary on the nut connection or caps because of O-ring seals.
- All plastic connections should be hand tightened. PTFE tape may be used on connections that do not use an O-ring seal. Do not use pipe dope type sealants on the valve body. **Do not use pliers or pipe wrenches, which can result in overtightening that may impact the product's operation.**
- Drain line requirements must be followed.
- Keep the cabinet tank in the upright position. Do not turn upside down or drop. Turning the tank upside down or laying the tank on its side can cause media to enter the valve.
- The pipe size for the drain line should be a minimum of ½". Backwash flow rates in excess of 7 gpm (26.5 lpm) or length in excess of 20' (6.1m) require a ¾" drain line.
- Do not support the weight of the system on the control valve fittings, plumbing, or the bypass.

Environmental

- Use only regenerants designed for water softening. Do not use ice melting salt, block salt, or rock salt.
- During cold weather it is recommended that the installer warm the valve to room temperature before operating.
- Do not use petroleum-based lubricants such as petroleum jelly, oils, or hydrocarbon-based lubricants. Use only 100% silicone lubricants.
- Do not allow this water softening system to freeze. Damage from freezing voids the warranty of this water softening system.
- **HYDROCARBONS SUCH AS KEROSENE, BENZENE, AND GASOLINE MAY DAMAGE PRODUCTS THAT CONTAIN O-RINGS OR PLASTIC COMPONENTS. EXPOSURE TO SUCH HYDROCARBONS MAY CAUSE THE PRODUCTS TO LEAK. DO NOT USE THE PRODUCT(S) LISTED IN THIS DOCUMENT ON WATER SUPPLIES THAT CONTAIN HYDROCARBONS SUCH AS KEROSENE, BENZENE, AND GASOLINE.**
- **THIS WATER METER SHOULD NOT BE USED AS THE PRIMARY MONITORING DEVICE FOR CRITICAL OR HEALTH EFFECT APPLICATIONS.**

Electrical

▲ WARNING

As with any electrical product, care should be taken to guard against the potential risk of fire, electric shock, and injury to persons.

- Use only the power transformer supplied with this water softening system.
- All electrical connections must be completed according to local codes.
- The power outlet must be grounded.
- All electrical connections must be connected according to local codes. (Be certain the outlet is uninterrupted.)
- Install grounding strap on metal pipes.
- **The power adapter comes with a 15-foot power cord and is designed for use with the control valve. The power adapter is for dry location use only.** The control valve remembers all settings until the battery power is depleted if the power goes out.
- After the battery power is depleted, the only item that needs to be reset is the time of day; other values are permanently stored in the nonvolatile memory. The control valve battery is not rechargeable but is replaceable.
- No user serviceable parts are on the PC board, the motor, or the power adapter. The means of disconnection from the main power supply is by unplugging the power adapter from the electrical outlet.
- Install an appropriate grounding strap across the inlet and outlet piping of the water softening system to ensure that a proper ground is maintained.
- To disconnect power, unplug the AC adapter from its power source.

Soldering

- Use only lead-free solder and flux, as required by federal and state codes, when installing soldered copper plumbing.
- Use caution when installing soldered metal piping near the water softening system. Heat can adversely affect the plastic control valve and bypass valve.
- Solder joints near the drain must be done before connecting the drain line flow control fitting. Leave at least 6" between the drain line control fitting and solder joints when soldering pipes that are connected on the drain line control fitting. Failure to do this could cause interior damage to the drain line flow control fitting.
- When assembling the installation fitting package (inlet and outlet), connect the fitting to the plumbing system first and then attach the nut, split ring, and O-ring. Heat from soldering or solvent cements may damage the nut, split ring, or O-ring. Solder joints should be cool and solvent cements should be set before installing the nut, split ring, and O-ring. Avoid getting primer and solvent cement on any part of the O-rings, split rings, bypass valve, or control valve.

▲ IMPORTANT SAFEGUARDS

Control Valve

- This glass-filled Noryl (or equivalent) fully automatic control valve is designed as the primary control center to direct and regulate all cycles of a water softener or filter.
- The control valve, fittings, and/or bypass are designed to accommodate minor plumbing misalignments but are not designed to support the weight of a system or the plumbing.
- The nuts and caps are designed to be unscrewed or tightened by hand or with a special plastic wrench. If necessary pliers can be used to unscrew the nut or cap. Do not use a pipe wrench to tighten or loosen nuts or caps. Do not place a screwdriver in the slots on caps and/or tap with a hammer.
- After completing any valve maintenance involving the drive assembly or the drive cap assembly and pistons, unplug the power source jack from the printed circuit board (black wire) then plug it back in or press and hold NEXT and REGEN buttons for 3 seconds. This resets the electronics and establishes the service piston position. The display should flash all wording, next flash the software version, and then reset the valve to the service position.
- The control valve is compatible with a variety of regenerants and resin cleaners. The control valve is capable of routing the flow of water in the necessary paths to regenerate or backwash water treatment systems. The injector regulates the flow of brine or other regenerants. The control valve regulates the flow rates for backwashing, rinsing, and the replenishing of treated water into a regenerant tank, when applicable.
- Control valve installation is made easy because the distributor tube can be cut ½" above to ½" below the top of tank thread. The distributor tube is held in place by an O-ring seal and the control valve also has a bayonet lock feature for upper distributor baskets.

Installation Preview

Conduct a visual check of all equipment for any damage that may have occurred during shipment.

NOTICE

If there is obvious damage to any equipment, it should be noted on the carrier's Bill Of Lading. Open and inspect the contents of closed crates, cartons, and other packaging, and inspect for concealed damage. The manufacturer is not liable for any damage during transit.

Position the equipment in its proper location, setting on a flat surface. Level equipment as required. Equipment out of plumb can exhibit poor flow characteristics, which affects the performance of the system.

NOTICE

Units are shipped with media (resin and gravel), distributions tube, and control valve installed. Double-check the valve installation on the tank. Tighten if necessary.

The unit should be positioned with the valve control facing forward.

Check the main line water pressure. The softener is designed for a minimum of 20 psi and a maximum of 125 psi working pressure. If the line pressure exceeds this limit, a pressure-reducing valve should be installed.

Maximum allowable water temperature is 40°F – 110°F (4°C – 38°C). A 120VAC 60 cycle electrical source must be available for operation of the controller.

Connect raw water supply line to the inlet valve connection. Connect treated water outlet to service line. It is suggested that the pipe size be equal or one size larger than the valve connection.

NOTICE

Softener should be located at least 10 feet away from hot water heater to protect against hot water back-up.

▲ WARNING

When piping with copper, solder all piping as subassemblies before installing. Internal damage can result from the high heat of the torch.

It is recommended that manual isolating valves be installed on the inlet and outlet piping along with a system bypass valve. This isolates the unit when service is required. Run drain line to a sump, drain trench, or other open drain. Open drains are required for taking samples and allowing a visual check. Avoid overhead pipe runs to drain facility, as undue backpressure affects the operation of injectors.

NOTICE

All piping is to meet your local and state codes. **AVOID CROSS CONNECTIONS!**

Position brine tank approximately 6" from the softener tank on a smooth surface.

Connect the brine air check assembly in the salt/brine tank to the brine suction (eductor) connection. If brine tank is located more than 6 feet from softener tank, use one size larger tubing. Tubing ⅝" should be installed from the brine tank overflow to drain. This is a gravity drain designed to divert brine to the drain in the event of a malfunction, which would cause overflow of the brine tank.

Be sure inlet/outlet isolating valves are closed and bypass valve is open.

▲ WARNING

Do not exceed water pressure of 120 psi (8.2 bar). Do not exceed 110°F (43.3°C). Do not subject unit to freezing conditions.

Preinstallation Considerations

Water Pressure

A minimum of 25 pounds of water pressure is required for regeneration valve to operate effectively. Do not exceed maximum water pressure of 125 pounds of water pressure.

Electrical Facilities

A continuous 120 volt, 60 hertz current supply is required. Make certain the current supply is always hot and cannot be turned off with another switch.

Existing Plumbing

Condition of existing plumbing should be free from lime and iron buildup. Piping that is built up heavily with lime and/or iron should be replaced. If piping is clogged with iron, a separate iron filter unit should be installed ahead of the water softener.

Where to Install the Softener

Consider the following points when determining where to install the water softener.

- Place the system as close as possible to a sewer drain.
- Do not install the softener where it would block access to the waterheater, or access to the main water shutoff, water meter, or electrical panels.
- Keep outside faucets on hard water to save soft water and salt.
- Install the softener in a place where water damage is least likely to occur if a leak develops.
- A 120VAC electrical outlet is needed to plug in the transformer. If the outlet is remote (up to 100 feet), use 18 gauge wire to connect.
- Always connect the system to the main water supply pipe before the water heater.
- Install the system where temperatures are within the limits stated in the Operating Parameters section but not in direct sunlight.

Bypass Valves

Always provide for the installation of a bypass valve.

Installation Instructions

1. Turn off water heater(s).
2. Turn off the main water supply to the home and open an inside faucet (cold and hot) to relieve any pressure within the plumbing system.

Remove Upper Cabinet Assembly

1. Standing in front of cabinet water softener, reach both hands around to back of upper cabinet assembly as shown in images below.
2. Gently pull the sides apart to disengage upper cabinet assembly from bottom cabinet assembly while lifting up.
3. To reinstall upper cabinet assembly, reverse this procedure while pushing down on upper cabinet assembly to lock into bottom cabinet assembly.

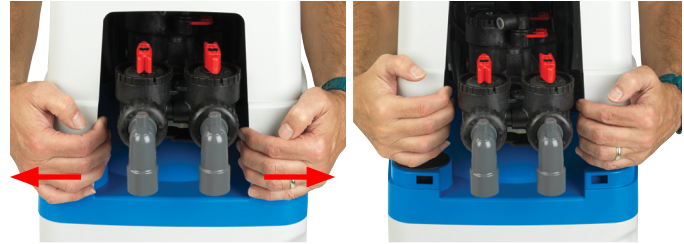

Select Location

1. Place the system in the desired installation location. Make sure that the location is level and sturdy enough to support the weight of the system once it is in operation.
2. Locate the water softener at least 10 feet away from the hot water heater so that hot water does not backup and damage the softener.
3. Make sure a drain is close by for disposal of regenerated wastewater.
4. If installing the softener in an outside locations, make sure to protect softener from the elements, such as freezing temperatures, rain, sunlight, and contamination

Install a Bypass

After a location has been determined, install bypass onto the control valve. (Figures 1 and 3 show standard bypass on valve. Figures 2 and 4 show 3-way bypass plumbing.)

NOTICE

Always install a bypass, either a 3-way valve system or the standard bypass, for the valve you have. This allows you to shut off the water supply to the softener, but still have water in the house if the softener is in need of repair.

If installing a 3-way bypass valve, do so now.

1. Close main water supply valve, at the well or at the water meter.
2. Shut off electrical or fuel supply to the water heater.
3. Open all faucets to drain pipes.

NOTICE

The bypass (provided) easily connects to the valve body using nuts that only require hand tightening. The split ring retainer design holds the nut on and allows the load to be spread over the entire nut surface area reducing the chance for leakage.

Make certain the nut is placed on first, then the split retainer ring, followed by the O-ring to make the seal. A silicon lubricant may be used on the black O-ring seals. This design allows for an approximate 2-degree misalignment of the plumbing but should never handle the weight of the plumbing system.

Move Water Softener Into Place

1. Connect the cold water supply to the inlet of the water softening system. While constructing the supply line, install a master supply valve (user supplied) in the supply line and close it.
2. Connect the feed water line to the home to the outlet of the system.
3. Make sure floor is level.

Measure, cut, and install pipe and fittings to the bypass valve (dry fit only to make sure you have a proper fit) on both the inlet and the outlet side. Be sure hard water is supplied to the inlet side. Trace pipe to be sure.

The installation fittings connect to the control valve or the bypass valve using nuts that only require hand tightening. Hand tighten nut connections between control valve and installation fittings, a control valve and bypass valve, and bypass valve and installation fittings allow for easy serviceability. Do not use a pipe wrench to tighten nuts on installation fittings. Hand tighten only.

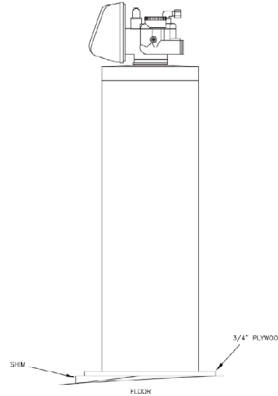

1" PVC MALE NPT ELBOW

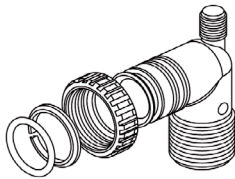

1" BRASS SWEAT

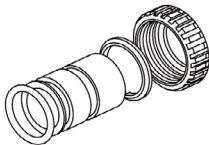

3/4" x 1" PVC SOLVENT ELBOW

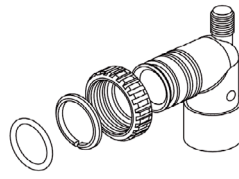

3/4" BRASS SWEAT

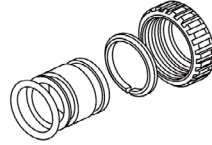

NOTICE

When assembling the installation fitting package, connect the fitting to the plumbing system first and then attach the nut, split ring, and O-ring. Heat from soldering or solvent cements may damage the nut, split ring, and O-ring. Make sure solder joints are cool before assembly is started.

Split ring retainer design holds the nut on and allows load to be spread over the entire nut surface area reducing the chance for leakage. The split ring design incorporated into the installation fittings allows approximately 2 degrees off axis alignment to the plumbing system. The installation fittings are designed to accommodate minor plumbing misalignments but are not designed to support the weight of a system or the plumbing.

When assembling the installation fitting package, connect the fitting to the plumbing system first and then attach the nut, split ring, and O-ring. Heat from soldering or solvent cements may damage the nut, split ring, or O-ring. Solder joints should be cool and solvent cements should be set before installing the nut, split ring, and O-ring. Avoid getting primer and solvent cement on any part of the O-rings, split rings, and bypass valve or control valve. Solvent cements and primers should be used in accordance with the manufacturer's instructions.

Slip the nut onto the fitting first, next the split ring, and then the O-ring. Hand tighten the nut. If the fitting is leaking, tightening the nut does not stop the leak. Remove the nut, remove the fitting, and check for damage or misalignment of the O-ring.

Do not use pipe dope or other sealant on threads. PTFE tape must be used on the threads of the 1" NPT elbow and the 1/4" NPT connection and on the threads for the drain line connection. PTFE tape is not necessary on the nut connection or caps because of O-ring seals.

Connect Brine Draw Line to Valve

Using the factory-supplied fittings and tubing, connect the brine draw line to the valve body at the 3/8" QC fitting on top of the valve. Connect the other end to the 3/8" QC fitting on top of brine well. Add enough water to the brine tank so that water covers the top of the air check. **DO NOT ADD SALT AT THIS TIME.**



Connect the Drain Line

1. Plumb the drain line to an appropriate drain abiding by all local, city, and state codes. Use a 3/4" drain line for backwash flow rates of 7 gpm or for drain lines of 7 gpm and less that exceed 20' in length. Use a 1" drain line for backwash flow rates of 10 gpm and 12 gpm.
2. If the drain line is a 5/8" flexible poly tube, slide the nut onto the poly tube, then place the poly tube insert into the end of the poly tube and tighten the nut on to the 3/4" drain line fitting. The nut is only designed for use with flexible poly tube. Use other nuts if attaching different materials. Run line to a drain, making sure you have a 1 1/2" air gap. You may use a floor drain, standpipe, or any open type drain. (See Figure 7.)

Do not use Vaseline, oils, or other unacceptable lubricants on O-rings. A silicon lubricant may be used on the black O-ring.

Use a pliers or crescent wrench to tighten or unscrew the nut. Do not use a pipe wrench to tighten or loosen nut. Do not use pipe dope or other sealant on threads. Use PTFE tape on the threads of the drain line control fitting when installing 3/4" NPT or 1" straight fitting.

Bypass Valve Installation

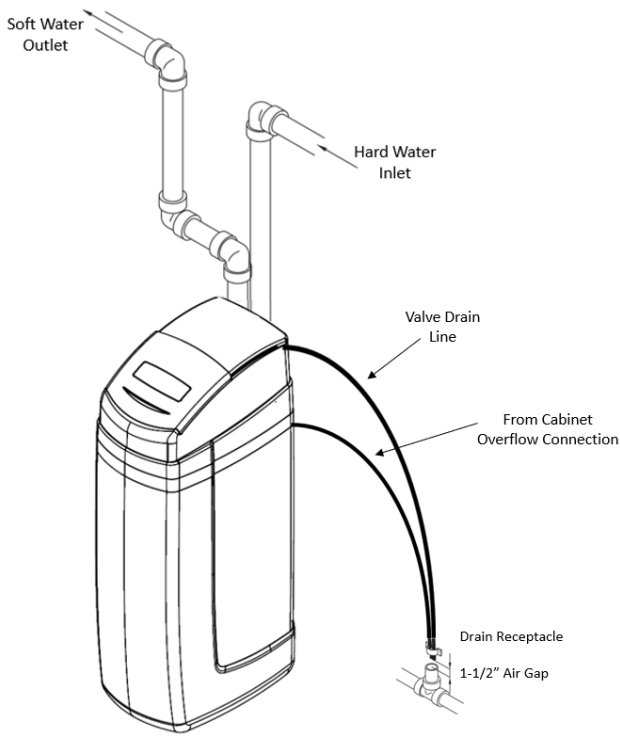

Figure 1 Plumbing with Standard Bypass

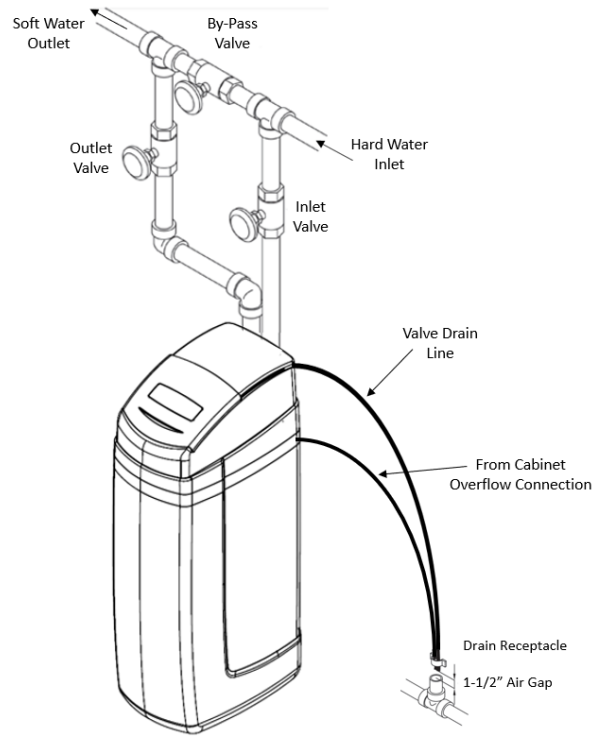

Figure 2 Plumbing with 3-Way Bypass

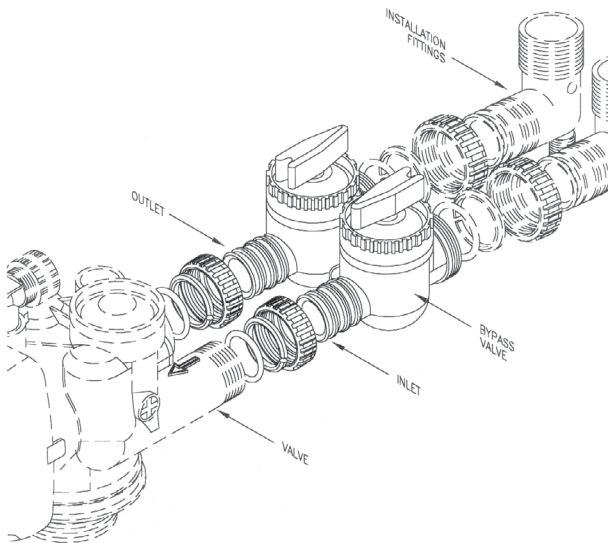

Figure 3 Bypass (standard)

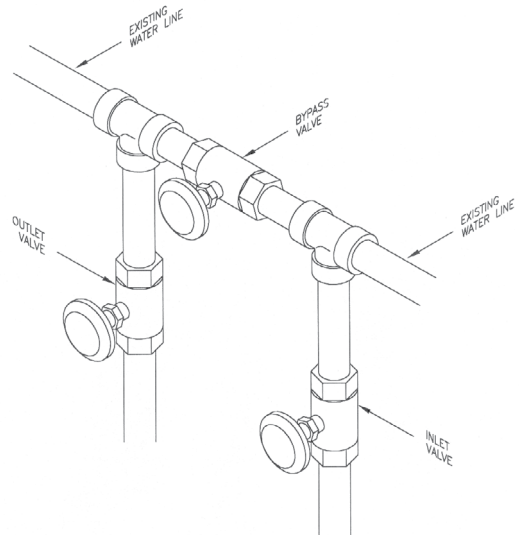

Figure 4 3-Way Bypass Plumbing

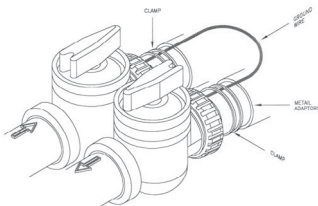

Figure 5

When installing sweat copper follow state and federal codes by using a lead-free solder and flux. Use a joint compound to seal threaded pipe. Some homes use the cold water pipes for an electrical ground (metal only). When finished with plumbing, a ground wire should be connected to the copper pipes to complete the ground circuit. Use two clamps and #4 copper for this.

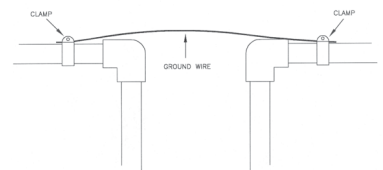

Figure 6

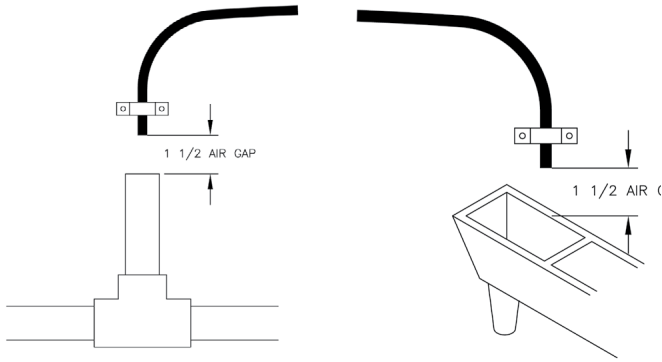

Figure 7 Required Air Gap for Drain Line

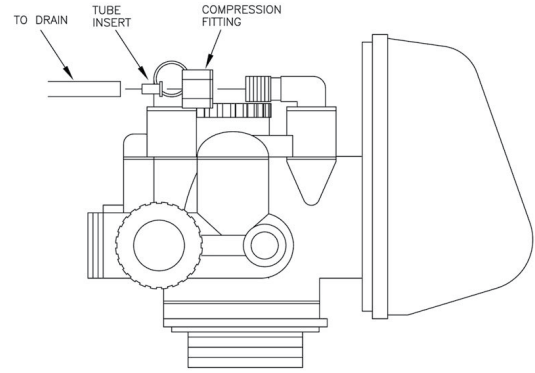

Figure 8 Drain Line Connection

Start Up

1. Place the bypass valve in the Bypass position or mode. (See Figures 9, 10, and 11.)
2. Open the user-supplied feed water valve. Check for leaks and repair as needed.
3. Open the outlet valve of the bypass.
4. Open a couple inside hot and cold faucets until all air has been purged from the plumbing system, then close the faucets.
5. Initiate an Immediate Manual Regeneration by pressing and holding the REGEN button for 3 seconds. This places the system into Backwash mode. Unplug the system from its electrical outlet once it has cycled into the backwash position. This stalls the unit in the Backwash mode so all air can be purged from the tank.
6. Close the bypass valve.
7. Adjust the user-supplied feed water valve to 1/4 open and place the bypass valve into the Service/Operating Mode position.
8. Air comes out of the drain line until the backwashing tank is completely purged of air. Then water flows to drain. Allow water to flow to drain for 15 minutes or until the water to drain is clear of resin color throw.
9. Plug the system back into the electrical outlet and manually cycle the control valve through the remaining regeneration steps by pressing the NEXT button until it arrives in the service position.
10. Check for system for leaks and repair as needed.
11. Installation is now complete and the system is ready for programming and one cycle of brine tank refill so that the correct amount of water is in the brine tank for the first regeneration cycle. The brine tank refill must be done after programming the system. Add salt to brine tank, and fill the brine tank about 1/2 full. **DO NOT FILL BRINE TANK COMPLETELY FULL.**

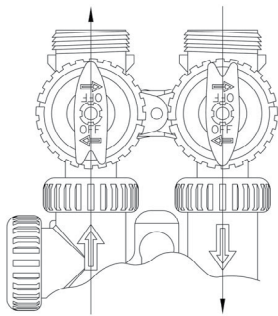

Figure 9 Operating Mode

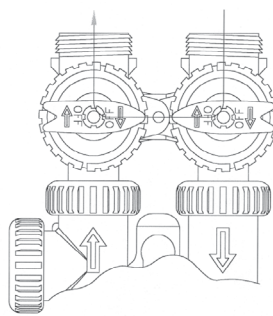

Figure 10 Bypass Mode

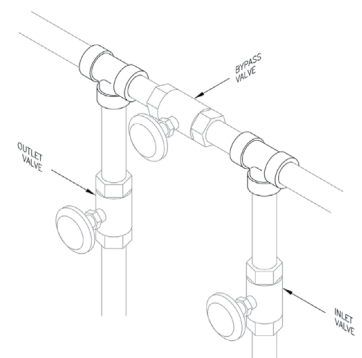

Figure 11 Bypass Mode

System Programming

A quick programming guide has been included for convenience, specifically for the PWSCAB series water softening system. (See Charts 1, 2, and 3.) For other programming requirements not listed, see the detailed programming sections that follow.

NOTICE

The electronics in the PWSCAB control valve are used across a wide variety of control valves and applications, including backwashing filters. All programming for the electronics has been included in this manual for reference.

NOTICE

The **Water Hardness** level of the feed water needs to be known before programming the system, as well as the **Water Softener Capacity** of the system being installed, to assure proper programming and efficiency of the system.

Chart 1: Setting Time of Day

Press Set Clock	Adjust hours using the UP and DOWN arrows.
Press NEXT to advance to the minutes	Adjust minutes with the UP and DOWN arrows.
Press NEXT to set time	Setting Time of Day completed.

NOTICE

Once in the programming settings, use the **UP** and **DOWN** arrows to change values.

Chart 2: Master Programming

To enter the Master Programming mode, press and hold the NEXT and DOWN arrows simultaneously for 3 to 5 seconds	The display changes to SET SOFTENING with the word SOFTENING blinking. This indicates you are now in the Master Programming Mode.
	System Type – For a WATER SOFTENER , leave this setting alone. If for some reason the display reads SET FILTER , press the UP arrow and change to SET SOFTENER .
Press NEXT	Capacity – Enter the CAPACITY of the water softener that you have; that is, 30K, 45K, 60K or 90K .
Press NEXT	Salt Setting – Enter the desired pounds of salt per regeneration. Example: 6 lb/cu ft of resin for highest efficiency; 15 lb/cu ft for maximum capacity. Default setting should be 9 pounds for a 45K water softener. Confirm the setting.
Press NEXT	A 30K water softener has 1 cu ft, 45K has 1.5 cu ft, 60K has 2 cu ft, and 90K cu ft has 3 cu ft. Example: 45K water softener would be set to a minimum salt setting of 9 pounds for highest efficiency (recommended).
Press NEXT	Backwashing Mode - Setting to Normal or Longer. NORMAL is the standard setting. LONGER may be needed for well water with heavier sediment issues. Contact Pure Water Technical Support at 1.800.224.1299, then press #2 for details.
Press NEXT	Gallon Capacity Mode - Set to AUTO for most efficient setting. Owner's manual has additional settings. Contact Pure Water Technical Support for details. Note: You may see a gallon capacity on this screen, press the UP arrow several times until you see AUTO on the screen.
Press NEXT	Brine Tank Refill Mode - Set to POST .
Press NEXT	Regenerate Flow Mode - Set to Down Flow – dn .
Press NEXT	Regeneration Time - Set to NORMAL .
Press NEXT	Master Programming completed.

NOTICE

Next you need to set up Installer Programming, this **MUST** be done in addition to the Master Programming.

Chart 3: Installer Programming

To enter Installation Display Setting Programming mode, press and hold the NEXT and UP arrow buttons simultaneously for 3 to 5 seconds	Hardness Setting - Set the level of hardness in grains per gallon (GPG) present in the raw water. Example: 18 grains per gallon (GPG). Adjust grains per gallon with the UP and DOWN arrows.
Press NEXT	Day Override. Default should be set to 14 Days. Watts Pure Water water softeners regenerate based on water usage, but this day override setting comes into play if the softener sits idle or has not regenerated. It initiates regeneration automatically regeneration on the 14th day.
Press NEXT	Regeneration Time. Default setting is 2:00 AM . If time change is needed, press the UP and DOWN arrows to adjust the hour time.
Press NEXT	Press the UP and DOWN arrows to adjust the minutes.
Press NEXT	Installer Programming completed. Valve returns to normal mode and is in service.

NOTICE

Next you need to initiate **Brine Tank Re-Fill** to complete start-up. This **MUST** be completed after Master Programming and Installer Programming are completed.

Step 1 – To initiate a manual regeneration, press and hold **REGEN** for 3 seconds.

Step 2 – Next you select the **REGEN** button repeatedly until you reach the FILL screen.

Step 3 – You will see a timer and it will start to count down and add water to Brine Tank.

Step 4 – Let this **Fill** cycle run to completion and it will automatically return to service mode.

You now have completed start up of your water softener.

If you have additional questions regarding you water softener programming, contact Pure Water Technical Support at 1.800.224.1299, then press #2.

Control Programming

Installer (I) Displays/Settings

STEP 1I – Press NEXT and UP arrow simultaneously for 3 seconds.

STEP 2I – Hardness: Set the amount of hardness in grains of hardness as calcium carbonate per gallon by using the DOWN or UP arrow. The default is 20 with value ranges from 1 to 150 in 1 grain increments. The grains per gallon can be increased if soluble iron needs to be reduced. Press NEXT to go to step 3I. Press REGEN to exit Installer Displays/Settings.

STEP 3I – Day Override: When gallon capacity is set to OFF, sets the number of days between regenerations. When gallon capacity is set to AUTO or to a number, sets the maximum number of days between regeneration. If value is set to OFF, regeneration initiation is based solely on gallons used. If value is set as a number (allowable range from 1 to 28), a regeneration initiation is called for on that day even if a sufficient number of gallons were not used to call for a regeneration. Set Day Override using the arrow buttons: number to days between regeneration (1 to 28); or OFF.

Press NEXT to go to step 4I. Press REGEN to return to previous step.

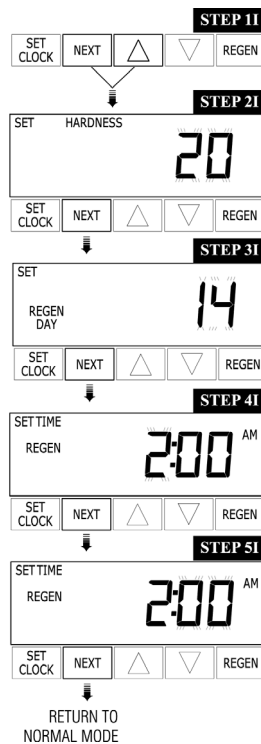

STEP 4I – Next Regeneration Time (hour): Set the hour of day for regeneration using the DOWN or UP arrow. AM/PM toggles after 12. The default time is 2:00 a.m. This display shows REGEN ON 0 GAL if ON 0 is selected in Step 9S or Step 7F. Press NEXT to go to step 5I. Press REGEN to return to previous step.

STEP 5I – Next Regeneration Time (minutes): Set the minutes of day regeneration using the DOWN or UP arrow. This display is not be shown if ON 0 is selected in Step 9S or Step 7F. Press NEXT to exit Installer Displays/Settings. Press REGEN to return to previous step.

To initiate a manual regeneration immediately, press and hold REGEN for 3 seconds. The system begins to regenerate immediately. The control valve may be stepped through the various regeneration cycles by pressing REGEN.

General Operation

User (U) Displays/Settings

When the system is operating one of two displays is shown. Pressing NEXT alternates between the displays. One of the displays is always the current time of day. The second display is one of the following: days remaining or gallons remaining. Days remaining are the number of days left before the system goes through a regeneration cycle. Capacity remaining is the number of gallons that to be treated before the system goes through a regeneration cycle. The user can scroll between the displays as desired.

If the system has called for a regeneration that occurs at the preset time of regeneration, the words REGEN TODAY are displayed.

When water is being treated (that is, water is flowing through the system), the word SOFTENING flashes on the display.

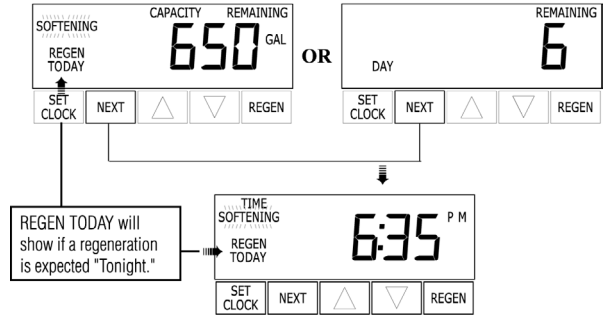

NOTICE

If brine tank does not contain salt, fill with salt and wait at least 2 hours before regenerating.

Regeneration Mode

Typically a system is set to regenerate at a time of low water usage. An example of a time with low water usage is when a household is asleep.

If there is a demand for water when the system is regenerating, untreated water is used.

When the system begins to regenerate, the display changes to include information about the step of the regeneration process and the time remaining for that step to be completed. The system runs through the steps automatically and resets itself to provide treated water when the regeneration has been completed.



Manual Regeneration

Sometimes there is a need to regenerate the system sooner than when the system calls for it, usually referred to as manual regeneration. There may be a period of heavy water usage because of guests or a heavy laundry day.

To initiate a manual regeneration at the preset delayed regeneration time, when the regeneration time option is set to NORMAL or NORMAL + ON 0, press and release REGEN. The words REGEN TODAY flash on the display to indicate that the system is set to regenerate at the preset delayed regeneration time. If you pressed REGEN in error, pressing the button again cancels the request. (Note: If the regeneration time option is set to ON 0, there is no set delayed regeneration time, so REGEN TODAY does not activate if REGEN is pressed.)

To initiate a manual regeneration immediately, press and hold REGEN for 3 seconds. The system begins to regenerate immediately. The request cannot be canceled.

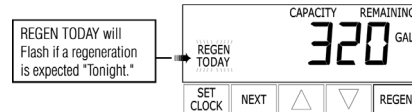

Clock Programming

Set Time of Day

Time of day should only need to be set after extended power outages or when daylight saving time begins or ends. If an extended power outage occurs, the time of day flashes on and off which indicates the time of day should be reset.

STEP 1U – Press SET CLOCK.

STEP 2U – Current Time (hour): Set the hour of the day using the DOWN or UP arrow. AM/PM toggles after 12. Press NEXT to go to step 3U.

STEP 3U – Current Time (minutes): Set the minutes of the day using the DOWN or UP arrow. Press NEXT to exit Set Clock. Press REGEN to return to previous step.

POWER LOSS If the power goes out for less than 2 hours, the system automatically resets itself. If an extended power outage occurs, the time of day flashes on and off which indicates the time of day should be reset. The system remembers the rest.

ERROR MESSAGE If the word ERROR and a number are alternately flashing on the display, contact the OEM for help. This indicates that the valve is unable to function properly.

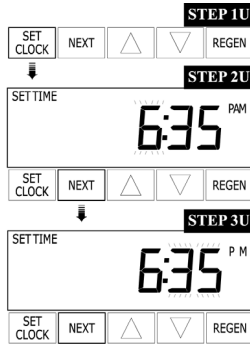

Sanitizing the System

1. At completion of softener installation, sanitize the system.
2. Remove the Upper Cabinet Assembly from the salt tank and then take the cap off of the brine well. (See the removal procedure under Installation Instructions.) Pour about 3/4 to 1 1/2 ounce of 5.25% common household bleach into the brine well. Replace cap and lid. (This can be done with or without salt in tank.)
3. Press and hold the regeneration button to start the regeneration process immediately.

Each water softener is handled in a manner to keep it clean and sanitary. The materials used during assembly and handling do not contaminate the water supply or cause bacteria to grow. However, during shipping, storage, installation, and operation, bacteria growth could develop. Some water supplies may require periodic disinfecting.

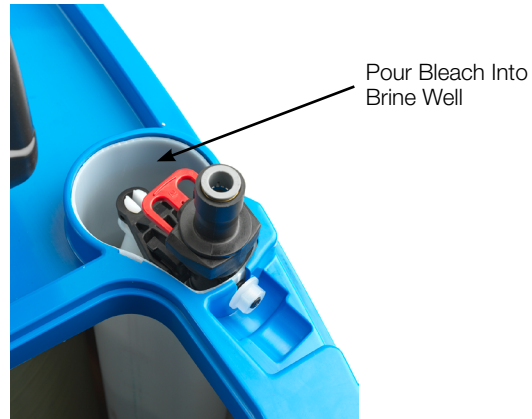

System Components

Components

The control valve consists of the following components:

- Drive Assembly
- Drive Cap Assembly, Main Piston and Regenerant Piston
- Spacer Stack Assembly
- Injector Cap, Screen, Injector Plug and Injector
- Refill Flow Control Assembly or Refill Port Plug
- Drain Line Flow Control and Fitting Assembly
- Water Meter or Meter Plug
- Installation Fitting Assemblies
- Bypass Valve (optional)

Drive Assembly

The drive assembly consists of the following parts:

- Drive Bracket
- Printed Circuit (PC) Board
- Motor
- Drive Gears
- Drive Gear Cover

The drive bracket holds the PC board, the motor, the drive gears, and the drive gear cover in place.

The PC board receives and retains information, displays the information, determines when to regenerate, and initiates regeneration. The display shows different types of information in the initial system setup (for softeners or filters), installer displays/settings, diagnostics, and valve history or user displays/settings.

The two-prong jack on the PC board connects wires to the direct current (DC) motor. The motor is held in place on the drive bracket by a spring-loaded clip and a small bulge in the plastic, which fits in one of the slots on the motor housing. The motor turns drive gears that drive the piston to cycle positions for backwashing, regeneration, rinsing, refill, or service. The motor is fully reversible (turns both ways) and changes direction of rotation to change the direction of piston motion. The motor is easily replaced if necessary.

There are three drive gears held in place by the drive gear cover. All three drive gears are the same size. A reflective coating is applied to the gears. As the center drive gear turns, a light shines on the coating and a light sensing diode determines if a light pulse was returned. The PC board counts the pulses and determines when to stop driving the motor.

Drive Cap Assembly with Main Piston and Regenerant Piston

The drive gears turn the main gear of the drive cap assembly, which moves the piston. The screw-driven, horizontally moving piston stops at specific positions to direct the flow of water to backwash, regenerate, rinse, or refill. The PC board determines the position of the piston by counting pulses produced when the piston is moved. An optical sensor looking at one of the reduction drive gears generates these pulses. Each cycle position is defined by a number of pulses. The counter is zeroed each time the valve goes to the service position. The PC board finds the service position by noting the increase in current delivered to the motor when the mechanical stop at the service position is reached. This method of controlling piston position allows for greater flexibility and requires no switches or cams.

One of two main pistons is always used.

- The down flow piston which is used when the control valve is applied as a down flow softener, regenerating filter, or non-regenerating filter.
- The up flow piston, which is used when the control valve is applied as an up flow softener.

If the control valve is used as a softener or a regenerating filter, a regenerant piston must be attached to the main piston. If the control valve is to be used on a system that does not require a regenerant to be added the regenerant, the piston must be removed.

Spacer Stack Assembly

The spacer stack assembly provides the necessary flow passage for water during the different cycles. The all-plastic spacer stack assembly (patent pending) is a one-piece design, which allows the stack to be removed by using the fingers.

The exterior of the stack is sealed against the body bore with self-lubricating EPDM O-rings while the interior surface is sealed against the piston using slippery self-cleaning directional (one-way) silicone lip seals. The lip seals are red or clear in color and have a special slippery coating so that the piston does not need to be coated or lubricated.

Injector

The screen, injector, and/or injector plug(s) are installed under the injector cap in an easy to access location on top of the valve. The injector cap contains four slots so no water accumulates in the cap. The injector cap is designed to be hand tightened.

Under the injector cap there is an easy to clean removable screen to prevent fouling of the injector. There are two holes under the injector cap labeled DN and UP. The holes are filled with a plug or an injector.

The plug (#KC113010-IZ) prevents water from traveling a certain pathway. The injector lets water pass through the pathway. The self-priming injector increases the velocity of the water, creating a zone of negative pressure that draws in the concentrated liquid regenerant, such as sodium chloride (brine), potassium permanganate, sodium hydroxide, and hydrochloric acid. The regenerant blends with the stream of water which passes through the media to regenerate the bed.

The injector provides a consistent regenerant-water mixture ratio over the entire operating pressure range of the control valve. The injector provides good performance in a variety of applications which may involve elevated drain lines and long regenerant draw lengths. Injectors are chosen by knowing the type, amount, and regenerant flow rate for a particular type of media. The color-coded injectors give different regenerant draw, slow rinse, and total flow rates over the pressure range. See Table 1 for color codes.

Table 1 Injector Order Information

Part Number	Color	Tank Diameter
KC11V3010-1D	Red	9"
KC11V3010-1E	White	10"
KC11V3010-1F	Blue	12"
KC11V3010-1G	Yellow	13"
KC11V3010-1I	Orange	16"
KC11V3010-1K	Lt Green	21"

Refill Flow Control Assembly

The refill flow control assembly consists of a refill flow elbow, refill flow control retainer assembly, refill flow control, poly tube insert, and nut assembly. The refill flow control retainer fits in the refill elbow. The refill flow control retainer houses the refill flow control, which controls the flow rate when the regenerant tank is being refilled. The refill flow control is a flexible washer-like part with a small orifice and a precision-molded contour that delivers a steady 0.5 gpm regenerant tank refill rate at varying inlet pressures. Refill is accomplished with treated water.

The refill flow control assembly is installed in an easy to access refill elbow located on top of the control valve. The refill flow control assembly is attached to the control valve with a locking clip. The locking clip allows the elbow to rotate 270 degrees so the outlet can be orientated toward the regenerant tank.

Drain Line Flow Control/Fitting

The drain line flow control assembly includes a drain line flow control and a fitting. The drain line flow control allows proper media bed expansion by regulating the flow rate to the drain.

The drain line flow control is a flexible washer-like part with an orifice and a precision molded contour. The flow rates are within $\pm 10\%$ over the pressure range of 30 to 125 psi. The flexible washer-like parts are identified with three numbers, which correspond to the flow rate in gallons per minute. See Table 2.

The drain line flow control and fitting are located on top of the control valve and replaceable without the use of special tools.

Table 2 Drain Line Flow Control (¾" Fitting)

Part Number	Number on Backwash Fitting	Flow Rate GPM
KC11V3162-022	22	2.2
KC11V3162-027	27	2.7
KC11V3162-042	42	4.2
KC11V3162-053	53	5.3
KC11V3162-075	75	7.5
KC11V3190-110	110	11.0

The drain line flow control can be installed in the standard ¼" drain line elbow, which accommodates ⅝" poly tube or ¾" NPT drain line connections. The optional nut and poly tube insert for the ¾" drain line elbow is designed for use with flexible poly tube only. The ¾" drain line elbow can be rotated 180 degrees so the outlet can be orientated to the nearest drain. The same retainer is used for all drain line flow controls for the ¾" fitting.

Water Meter or Meter Plug

The water meter is installed on the outlet side of the control valve. The water meter uses a turbine to total gallons of treated water. The turbine rotates with the flow of water and reports its rate of rotation through Hall-effect 8 circuitry to the printed circuit (PC) board. This rotation permits the PC board to record the total volume of treated water and the flow rate. The small centrally located magnet is shielded from water, which reduces substantially iron-fouling problems with the turbine. The turbine is accurate to within $\pm 5\%$ over a wide operating flow rate range (0.25 gpm up to control valve maximums) and has a very low pressure drop. Water used for regeneration is not metered. If the control valve is set to prefill the regenerant, water used between the prefill cycle up to the start of the regeneration cycle is metered. If the control valve is in regeneration mode (such as a backwash cycle) and there is a water demand, that water usage is not metered.

When facing the front of the control valve, the water meter is positioned on the left-hand side of the control valve. Allow sufficient clearance to clean and repair the water meter without disconnecting the plumbing or disassembling any other parts of the control valve.

A unique feature of this control valve is the ability to display actual water usage for the last 63 days. The value is initially stored as "-" because it is unknown. As days pass values are stored as "O" for no flow or the actual number of gallons. The counting of the gallons starts at the regeneration time. If no regeneration time can be set (that is, when the valve is set for immediate regeneration), the counting of gallons starts at 12 a.m. Day 1 is yesterday, day 2 the day before yesterday, and so on. As new values are added the oldest history disappears.

Another unique feature is that the valve automatically calculates a reserve capacity when set up as a softener with Gallons Capacity set to AUTO. The reserve capacity for a given day of the week is the middle value stored for the last three non-trivial water usages (that is, less than 20 gallons per day) in 7-day intervals, which is then adjusted either upward or downward depending upon the difference between today's water usage and the estimated reserve capacity.

Installation Fitting Assemblies

The installation fittings are used to connect the optional bypass or the control to the plumbing system. There are four installation fitting assemblies available.

- 1" NPT elbow
- ¾" and 1" PVC solvent weld elbow fitting
- 1" straight brass sweat fitting*
- ¾" straight brass sweat fitting*

Both elbow fittings have a unique drill-out feature to allow a ¼" NPT connection to the inlet and/or outlet which can be used for an RO feed, test ports, pressure tap ports, or other apertures.

The installation fitting assemblies are sold in pairs and consist of 2 fittings, 2 nuts, 2 split rings, and 2 O-rings. The installation fitting assemblies and the bypass valve are sold separately from the control valve.

Note: Some semiconductor materials exhibit a phenomenon in the presence of a magnetic field that is adaptable to sensing devices. When a current is passed through one pair of wires attached to a semiconductor, another pair of wires properly attached and oriented with respect to the semiconductor develop a voltage proportional to the magnetic field present and the current in the other pair of wires. Holding the exiting current constant and moving a permanent magnet near the semiconductor produces a voltage output proportional to the movement of the magnet. Hall-effect devices provide a high-speed response, excellent temperature stability and no physical contact.

*Has not been tested for compliance with California Proposition 65 so this fitting should not be installed in California.

Bypass Valve

The bypass valve is typically used to isolate the control valve from the plumbing system's water pressure in order to perform control valve repairs or maintenance. The W100SM bypass valve is particularly unique in the water treatment industry due to its versatility and state-of-the-art design features. The 1" full flow bypass valve incorporates four positions including a diagnostic position that allows service personal to work on a pressurized system while still providing untreated bypass water to the facility or residence. Its completely non-metallic, all-plastic design allows for easy access and serviceability without the need for tools.

The bypass body and rotors are glass-filled Noryl and the nuts and caps are glass filled polypropylene. All seals are self-lubricating EPDM to help prevent valve seizing after long periods of non-use. Internal O-rings can easily be replaced if service is required.

The bypass consists of two interchangeable plug valves that are operated independently by red arrow-shaped handles. The handles identify the flow direction of the water. The plug valves enable the bypass valve to operate in four positions.

Normal Operation: The inlet and outlet handles point in the direction of flow indicated by the engraved arrows on the control valve. Water flows through the control valve during normal operation and this position also allows the control valve to isolate the media bed during the regeneration cycle.

Bypass Operation: The inlet and outlet handles point to the center of the bypass, the control valve is isolated from the water pressure contained in the plumbing system. Untreated water is supplied to the plumbing system.

Diagnostic Mode: The inlet handle points in the direction of flow and the outlet handle points to the center of bypass valve. System water pressure is allowed to the control valve and the plumbing system while not allowing water to exit from the control valve to the plumbing.

Shutoff Mode: The inlet handle points to the center of the bypass valve and the outlet handle points in the direction of flow. The water is shut off to the plumbing system. If water is available on the outlet side of the softener, it is an indication of water bypass around the system (that is, a plumbing connection somewhere in the building bypasses the system).

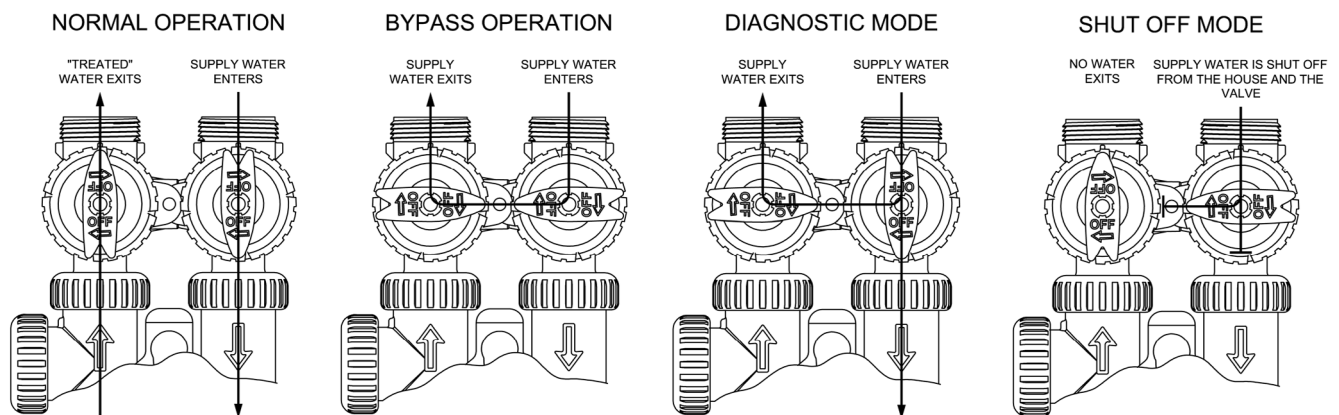

Drawings and Part Numbers

Front Cover and Drive Assembly

DRAWING NO.	ORDER NO.	DESCRIPTION	QTY.
1	7300839	W100SM Front Cover ASY	1
2	7300833	W100SM Motor	1
3	KC12F3106-01	W100SM Drive Bracket & Spring Clip	1
4	7300834	W100SM PC Board	1
5	KC12V3110	W100SM Drive Gear 12x36	3
6	KC12V3109	W100SM Drive Gear Cover	1
	KC12V3002	W100SM Drive ASY	*
Not Shown	7300838	W100SM Transformer 110V-12V	1

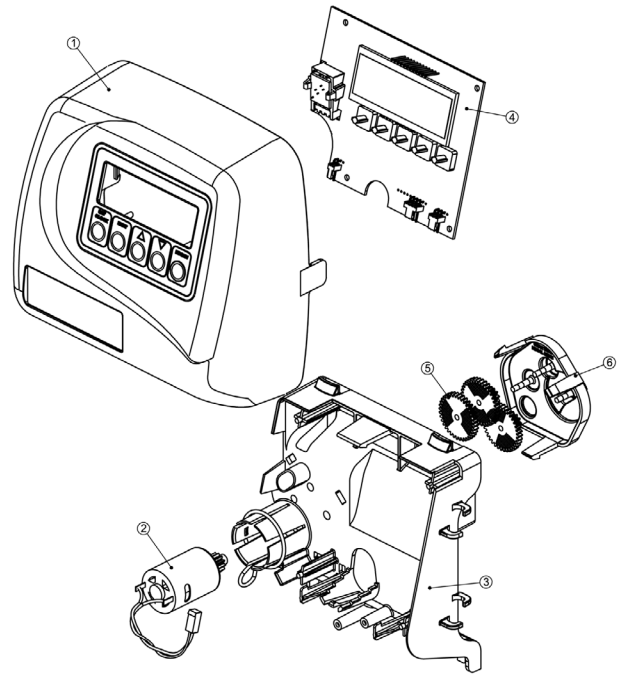

Drive Cap Assembly, Downflow Piston, Upflow Piston, Regenerant Piston, and Spacer Stack Assembly

DRAWING NO.	ORDER NO.	DESCRIPTION	QTY.
1	7300826	W100SM Spacer Stack Assembly	1
2	KC12V3004	Drive Cap ASY	1
3	KC12V3135	O-ring 228	1
4	7300832	W100SM Piston Downflow ASY	1
5	7300836	W100SM Regenerant Piston	3
6	KC12V3180	O-ring 337	1

Note: The regenerant piston is not used in backwash only applications.

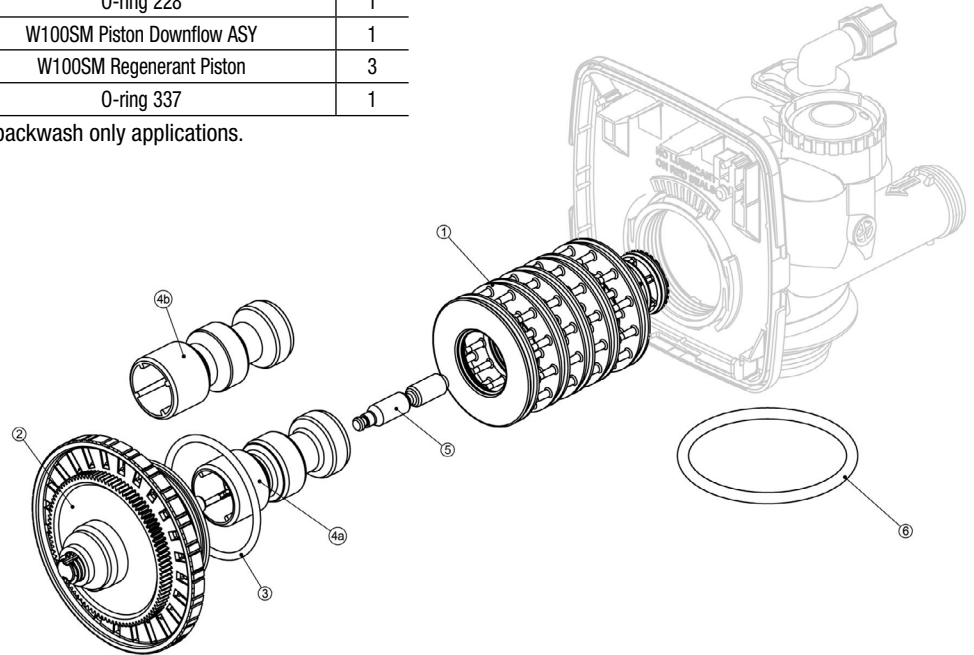

Injector Cap, Injector Screen, Injector, Plug, and O-ring

Drawing No.	Order No.	Description	Qty.
1	KC12V3176	Injector Cap	1
2	KC12V3152	O-ring 135	1
3	KC12V3177	Injector Screen	1
4	KC12V3010-12	W100SM Injector ASY Z Plug	1
5	KC12V3010-10	W100SM Injector ASY D Red	1
	KC12V3010-IE	W100SM Injector ASY E White	
Not Shown	KC12V3170	O-ring 011	*
Not Shown	KC12V3171	O-ring 013	*

*The Injector plug and the injector each contain one 011 (lower) and 013 (upper) O-ring.

Note: For upflow position, injector is located in the up hole and injector plug in the down hole. For a filter that only backwashes, injector plugs are located in both holes.

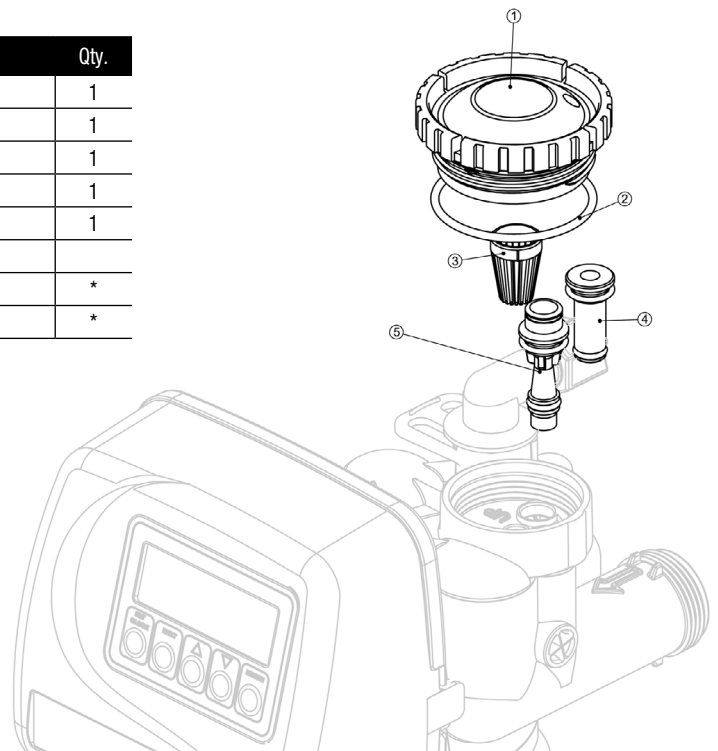

Brine Line Connection

ORDER NO.	DESCRIPTION
V4144-01	3/8" Quick Connect Fitting

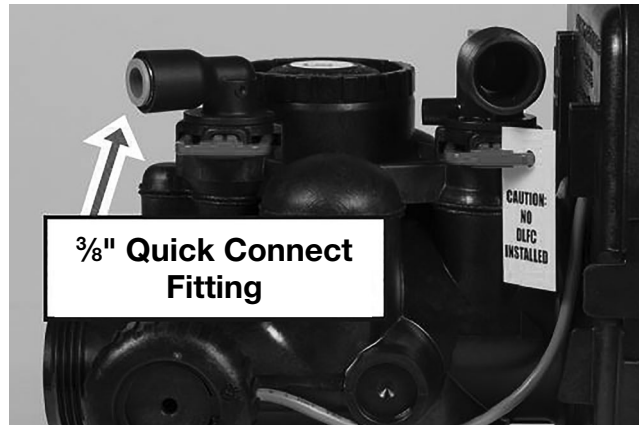

Drain Line - 3/4"

DRAWING NO.	ORDER NO.	DESCRIPTION	QTY.
1	KC12H4615	Elbow Locking Clip	1
2	KC12PKP10T58	Polytube insert 5/8	Option
3	KC12V3192	W100SM Nut 3/4 Drain Elbow	Option
4	KC12V3158-01	W100SM Drain Elbow 3/4 Male ASY	1
5	KC12V3163	O-ring 019	1
6	KC12V3159-01	W100SM DLFC Retainer ASY	1
7	KC12V3162-022	W100SM DLFC 2.2 gpm for 3/4	*
Not Shown	KC12V3162-027	W100SM DLFC 2.7 gpm for 1"	*

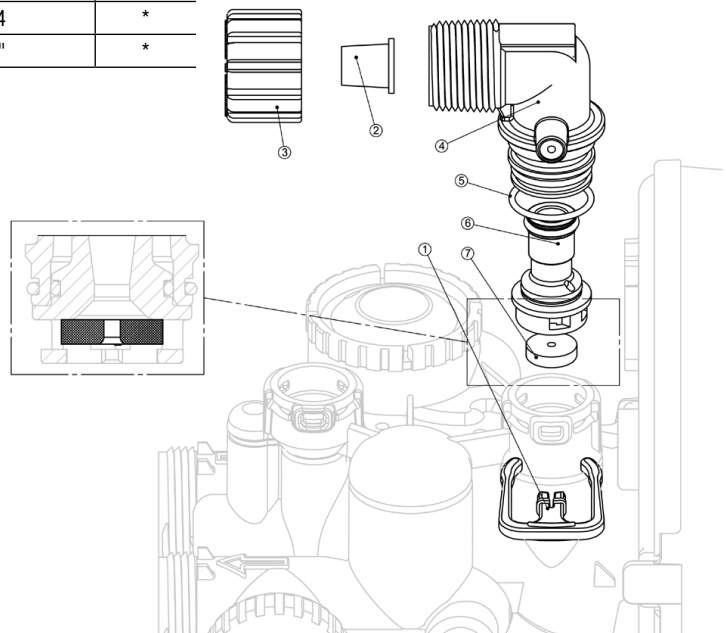

Water Meter and Meter Plug

ORDER NO.	DESCRIPTION
7300827	Water Meter Plug Assembly

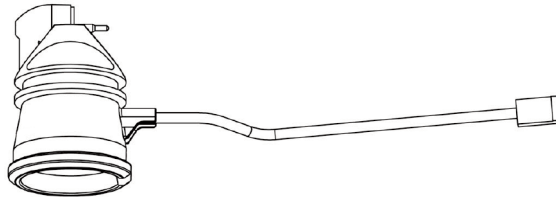

Installation Fitting Assemblies

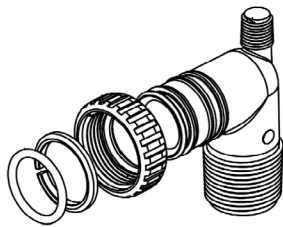

ORDER NO.	DESCRIPTION
0002169	1" PVC Male NPT Elbow (pair)

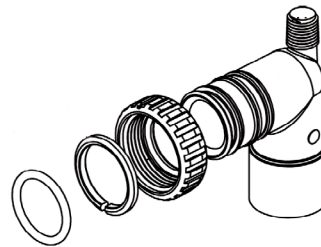

ORDER NO.	DESCRIPTION
KC11V3007-01	3/4" & 1" PVC Socket 90 Elbow (pair)

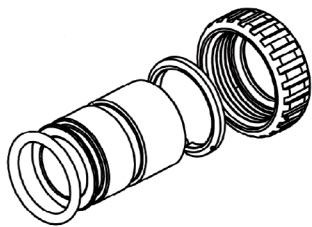

ORDER NO.	DESCRIPTION
0002170	1" Brass Sweat

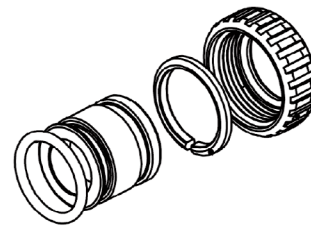

ORDER NO.	DESCRIPTION
0002171	3/4" Brass Sweat (pair)

Bypass Valve Assembly

ORDER NO.	DESCRIPTION
0002167	Bypass Valve Assembly

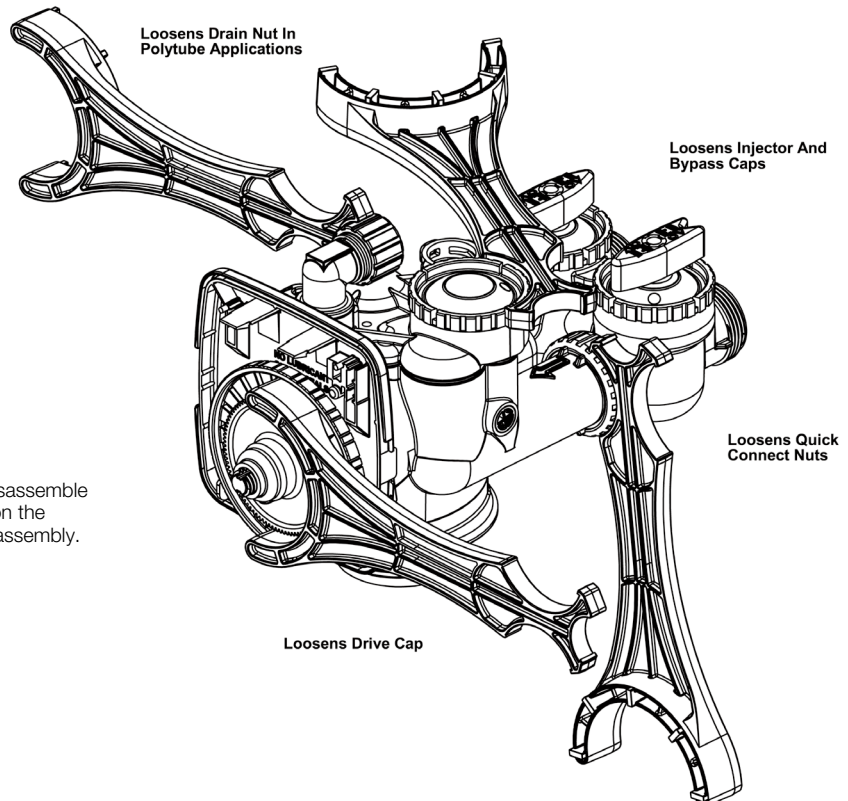
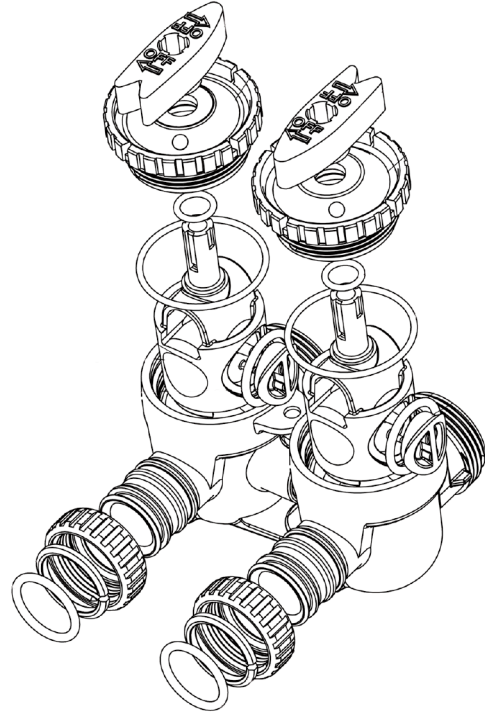

Wrench

(Order No. 7300839)

Although no tools are necessary to assemble or disassemble the valve, the wrench (shown in various positions on the valve) may be purchased to aid in assembly or disassembly.

Flow Diagram...Service

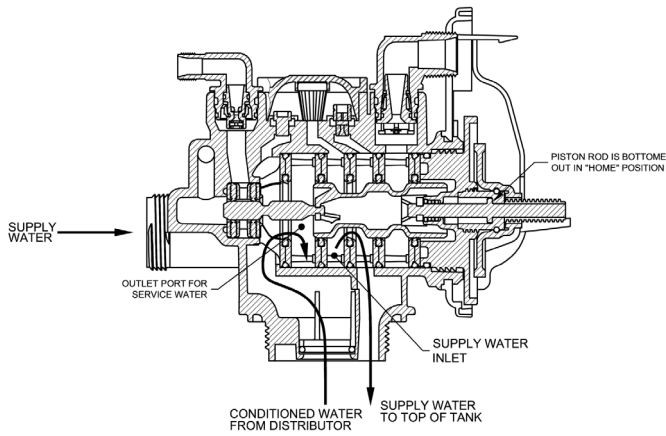

Flow Diagram...Rinse

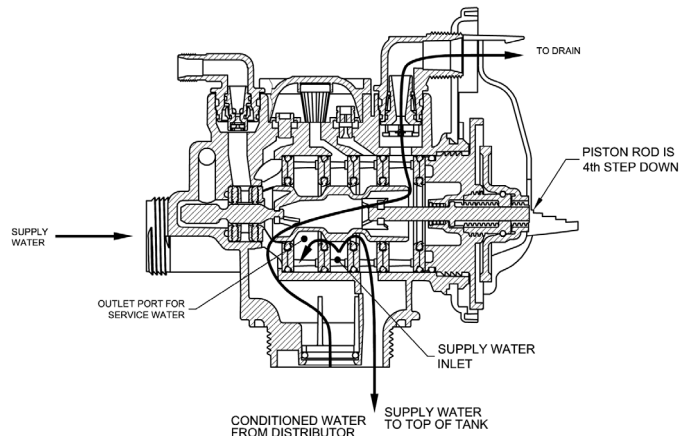

Flow Diagram...Backwash

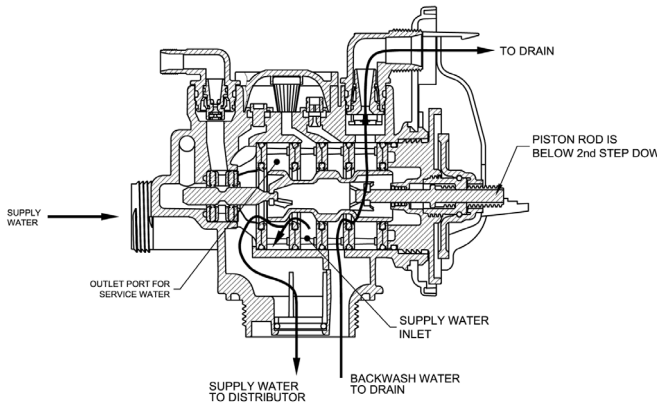

Flow Diagram...Fill

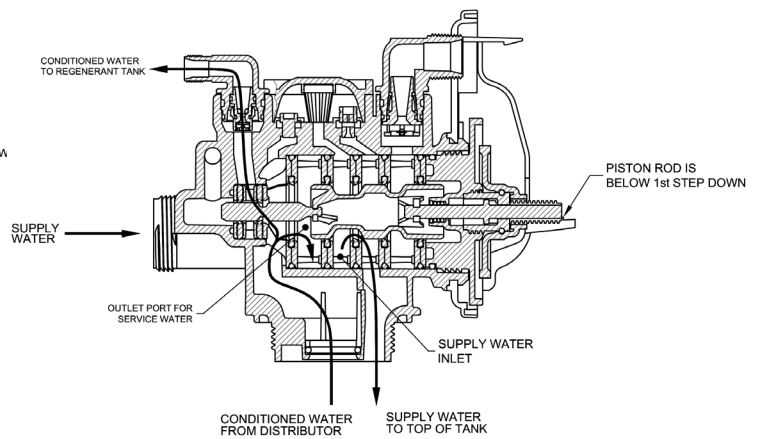

Flow Diagram...Downflow Brine

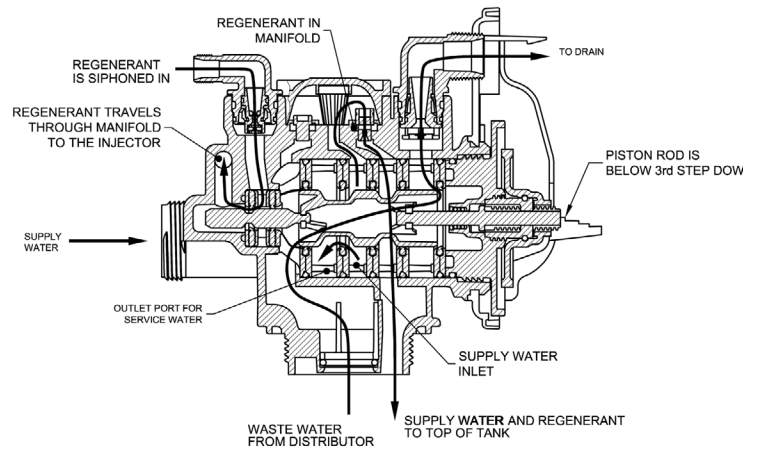

Troubleshooting

System Troubleshooting

Problem	Cause	Correction
Loss of resin.	Broken distribution tube.	Replace distribution tube.
	Inlet/Outlet connection reversed.	Reconnect inlet/outlet connection properly.
Softener fails to regenerate.	Electrical service to unit has been interrupted.	Assure permanent electrical service (check fuse, plug, pull chain, or switch).
	Timer is defective.	Replace timer.
	Power failure.	Reset time of day.
Water is hard/not softened.	Bypass valve is open.	Close bypass valve.
	No salt in brine tank.	Add salt to brine tank and maintain salt level above water level.
	Injector screen plugged.	Clean injector screen.
	Insufficient water flowing into brine tank.	Check brine tank fill time and clean brine line flow control if plugged.
	Hot water tank hardness	Repeated flushing of the hot water tank is required.
	Leak at distributor tube.	Make sure distributor tube is not cracked. Check "O" Ring and tube pilot.
	Internal valve leaking.	Replace seals and spacers and or piston.
Unit used too much salt.	Improper salt setting.	Check salt usage and sat setting.
	Excessive water in brine tank.	See problem "Excessive water in brine tank."
Loss of water pressure.	Iron buildup in line to water conditioner.	Clean line to water softener.
	Iron buildup in water softener.	Clear control and add mineral cleaner and Increase frequency regeneration.
	Inlet of control plugged due to foreign material broken loose from pipes by recent work done on plumbing system.	Remove piston and clean control.
Loss of mineral through drain line.	Air in water system.	Assure that well system has proper air eliminator control. Check for dry well condition.
Iron in conditioned water.	Fouled mineral bed.	Check backwash, brine draw, and brine tank fill. Increase frequency of regeneration. Increase backwash time.

System Troubleshooting, cont.

Problem	Cause	Correction
Excessive water in brine tank.	Plugged drain line flow control.	Clean flow control.
	Plugged injector system.	Clean injector and screen.
	Foreign material in brine valve.	Replace timer.
	Defective controller.	Replace controller.
	Foreign material in brine line flow control.	Clean brine line flow control.
Softener fails to draw brine.	Drain line flow control is plugged.	Clean drain line flow control.
	Injector is plugged.	Clean injector.
	Injector screen plugged.	Clean screen.
	Line pressure is too low.	Increase line pressure to 20 psi.
	Internal control leak.	Change seals, spacers, and piston assembly.
Control cycles continuously.	Broken or shorted switch.	Determine if switch or timer is faulty and replace it, or replace complete power head.
Drain flows continuously.	Piston is not positioned correctly when in service.	Check timer program and positioning of control. Replace power head assembly if not positioning properly.
	Foreign material in control.	Remove power head assembly and inspect bore. Remove foreign material and check control in various regeneration positions.
	Internal control leak.	Replace seals and piston assembly.
Brine tank fills during brine step.	Clogged drain.	Replace drain line.
	Internal piston seal leaks.	Replace seals in piston assembly.

Programming Troubleshooting

Problem	Possible Cause	Solution
Timer does not display time of day.	Transformer unplugged.	Connect power.
	No electric power at outlet.	Repair outlet or use working outlet.
	Defective transformer.	Replace transformer.
	Defective PC board.	Replace PC board.
Timer does not display correct time of day.	Switched outlet.	Use uninterrupted outlet.
	Power outage.	Reset time of day.
	Defective PC board.	Replace PC board.
No softening display.	Bypass valve in bypass position.	Put bypass valve in service position.
	Restricted/stalled meter turbine.	Remove meter and check for rotation or foreign material.
	Defective meter.	Replace meter.
	Defective PC board.	Replace PC board.
Control valve regenerates at wrong time of day of day.	Power outages.	Reset control valve to correct time.
	Time of day not set correctly.	Reset to correct time of day.
	Time of regeneration incorrect.	Reset regeneration time.
	Control valve set at ON 0 (immediate regeneration).	Check control valve setup procedure regeneration time option.
	Control valve set at NORMAL ON 0.	Check control valve setup procedure regeneration time option.
<p>ERROR followed by code number:</p> <p>Error Code 1001 - Unable to recognize start of regeneration.</p> <p>Error Code 1002 - Unexpected stall.</p> <p>Error Code 1003 - Motor ran too long, timed out trying to reach next cycle position.</p> <p>Error Code 1004 - Motor ran too long, timed out trying to reach home position.</p> <p>If other Error Codes display, contact the factory.</p>	Control valve has just been serviced.	Press NEXT and REGEN for 3 seconds or unplug power source Jack (black wire) and plug back in to reset control valve.
	Foreign matter is lodged in control valve.	Check piston and spacer stack assembly for foreign matter.
	High drive forces on piston.	Replace piston(s) and spacer stack assembled.
	Control valve piston not in home position.	Press NEXT and REGEN for 3 seconds or unplug power source jack (black wire) and plug back into reset control valve.
	Motor not inserted fully to engage pinion, motor wires broken or disconnected, motor failure.	Check motor and wiring. Replace motor if necessary.
	Drive gear label dirty or damaged missing or broken gear.	Replace or clean drive gear.
	Drive bracket incorrectly aligned to back plate.	Reset drive bracket properly.
	PC board is damaged or defective.	Replace PC board.
	PC board incorrectly aligned to drive bracket.	Ensure PC board is correctly snapped on to drive.

Programming Troubleshooting, cont.

Problem	Possible Cause	Solution
Control valve stalled in regeneration.	Motor not operating.	Replace motor.
	No electric power at outlet.	Repair outlet or use working outlet.
	Defective transformer.	Replace transformer.
	Defective PC board.	Replace PC board.
	Broken drive gear or drive cap assembly.	Replace drive gear or drive cap assembly.
	Broken piston retainer.	Replace drive cap assembly.
	Broken main or regenerant piston.	Replace main or regenerant piston.
Control valve does not regenerate automatically when REGEN button is depressed and held.	Transformer unplugged.	Connect transformer.
	No electric power at outlet.	Repair outlet or use working outlet.
	Broken drive gear or drive cap assembly.	Replace drive gear or drive cap assembly.
	Defective PC board.	Replace PC board.
Control valve does not regenerate automatically but does when REGEN button is depressed.	Bypass valve in bypass position.	Put control valve in service position.
	Meter connection disconnected.	Connect meter to PC board.
	Restricted/stalled meter turbine.	Remove meter and check for rotation or foreign matter.
	Defective meter.	Replace meter.
	Defective PC board.	Replace PC board.
	Setup error.	Check control valve setup procedure.
Time of day flashes on and off.	Power has been out more than 2 hours, the transformer was unplugged and then plugged back into the wall outlet, the transformer plug was unplugged and then plugged back into the board or the NEXT and REGEN buttons were pressed to reset the valve.	Reset the time of day.

LIMITED WARRANTY: Certain Watts Pure Water products come with a limited warranty from Watts Regulator Co. Other products may have no warranty or are covered by the original manufacturer's warranty only. For specific product warranty information, please visit www.watts.com or the published literature that comes with your product. Any remedies stated in such warranties are exclusive and are the only remedies for breach of warranty. **EXCEPT FOR THE APPLICABLE PRODUCT WARRANTY, IF ANY, WATTS MAKES NO OTHER WARRANTIES, EXPRESS OR IMPLIED. TO THE FULLEST EXTENT PERMITTED BY APPLICABLE LAW, WATTS HEREBY SPECIFICALLY DISCLAIMS ALL OTHER WARRANTIES, EXPRESS OR IMPLIED, INCLUDING BUT NOT LIMITED TO THE IMPLIED WARRANTIES OF MERCHANTABILITY AND FITNESS FOR A PARTICULAR PURPOSE, AND IN NO EVENT SHALL WATTS BE LIABLE, IN CONTRACT, TORT, STRICT LIABILITY OR UNDER ANY OTHER LEGAL THEORY, FOR INCIDENTAL, INDIRECT, SPECIAL OR CONSEQUENTIAL DAMAGES, INCLUDING, WITHOUT LIMITATION, LOST PROFITS OR PROPERTY DAMAGE, REGARDLESS OF WHETHER IT WAS INFORMED ABOUT THE POSSIBILITY OF SUCH DAMAGES.**

