

# Engineering Specification

Job Name \_\_\_\_\_

Contractor \_\_\_\_\_

Job Location \_\_\_\_\_

Approval \_\_\_\_\_

Engineer \_\_\_\_\_

Contractor's P.O. No. \_\_\_\_\_

Approval \_\_\_\_\_

Representative \_\_\_\_\_

Tag \_\_\_\_\_

## FD10 Adjustable Drain for Wooden Floors

### Specifications

Watts Light Commercial FD10 PVC, ABS, or cast iron adjustable drain for wooden floors with heel proof nickel bronze strainer and countersunk steel mounting flange.



| Pipe Sizing |                |                          |
|-------------|----------------|--------------------------|
| Suffix      | Description    |                          |
| -2PVC       | 2"(51) PVC     | <input type="checkbox"/> |
| -2ABS       | 2"(51) ABS     | <input type="checkbox"/> |
| -2NH        | 2"(51) No Hub  | <input type="checkbox"/> |
| -3PVC       | 3"(76) PVC     | <input type="checkbox"/> |
| -3ABS       | 3"(76) ABS     | <input type="checkbox"/> |
| -3NH        | 3"(76) No Hub  | <input type="checkbox"/> |
| -4PVC       | 4"(102) PVC    | <input type="checkbox"/> |
| -4ABS       | 4"(102) ABS    | <input type="checkbox"/> |
| -4NH        | 4"(102) No Hub | <input type="checkbox"/> |

| Options |                     |                          |
|---------|---------------------|--------------------------|
| Suffix  | Description         |                          |
| -B      | Sediment Bucket     | <input type="checkbox"/> |
| -BV     | Backwater Valve     | <input type="checkbox"/> |
| -G      | CI Round Funnel     | <input type="checkbox"/> |
| -GNB    | NB Round Funnel     | <input type="checkbox"/> |
| -H      | CI Oval Funnel      | <input type="checkbox"/> |
| -HNB    | NB Oval Funnel      | <input type="checkbox"/> |
| -VP     | Vandal Proof Screws | <input type="checkbox"/> |

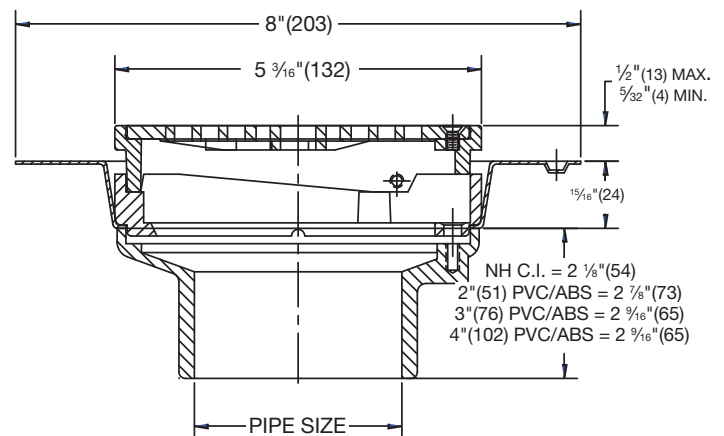

### NOTICE

The information contained herein is not intended to replace the full product installation and safety information available or the experience of a trained product installer. You are required to thoroughly read all installation instructions and product safety information before beginning the installation of this product.

Watts product specifications in U.S. customary units and metric are approximate and are provided for reference only. For precise measurements, please contact Watts Technical Service. Watts reserves the right to change or modify product design, construction, specifications, or materials without prior notice and without incurring any obligation to make such changes and modifications on Watts products previously or subsequently sold.



**USA:** T: (800) 338-2581 • F: (828) 248-3929 • Watts.com  
**Canada:** T: (888) 208-8927 • F: (905) 481-2316 • Watts.ca  
**Latin America:** T: (52) 55-4122-0138 • Watts.com