

- NOTES:
- ALL DIMENSIONS SHOWN IN TABLE ARE IN INCHES, UNLESS OTHERWISE NOTED & ARE ± 1 INCH (25MM).
 - ALL ITEMS SHOWN IN PHANTOM LINE ARE TO BE PROVIDED BY OTHERS.
 - ALL DIMENSIONS ARE SUBJECT TO CHANGE WITHOUT ANY NOTICE.
 - INSTALL UNIONS FITTINGS ON INLET, OUTLET & DRAIN PLUMBING CONNECTIONS.
 - PROVIDE A 2 FEET MINIMUM CLEARANCE ABOVE MINERAL TANK FOR FILLING MEDIA.
 - A GFCI EQUIPT ELECTRICAL OUTLET SHOULD BE PROVIDED WITHIN 5 FEET OF EQUIPMENT LOCATION.
 - USE DIELECTRIC UNIONS ON PLUMBING CONNECTIONS OF CONTROL VALVE WHEN DISSIMILAR METALS ARE PRESENT.
 - PROVIDED SYSTEM SHALL NOT BE SUBJECT TO ANY VACUUM. IF RISK OF VACUUM IS PRESENT, INSTALL SIPHON BREAK ON DRAIN LINE & INSTALL VACUUM RELIEF VALVE WATTS ORDERING CODE # 0556031 ON INLET LINE.
 - BRINE TANK DIMENSIONS SHOWN ON TABLE ARE FACTORY SELECTED FOR USE WITH THE SPECIFIED SYSTEM SIZE.
 - DO NOT INSTALL DRAIN LINE DIRECTLY TO A DRAIN. FOR PROPER DRAIN CONNECTION FOLLOW ALL NATIONAL, STATE AND LOCAL CODES. DO NOT CONSTRUCT DRAIN LINE TO ELEVATIONS THAT EXCEED 4 FEET ABOVE THE CONTROL VALVE'S DRAIN PORT.
 - THE FULL WEIGHT OF THE PIPING AND VALVES MUST BE SUPPORTED BY PIPE HANGERS OR OTHER MEANS.
 - INLET AND OUTLET HEADERS NEED TO BE SIZED ACCORDING TO FLOW RATE REQUIREMENTS BY OTHERS.
 - POWER REQUIREMENTS: 115V/60HZ 2.7 AMPS PER CONTROL VALVE UNLESS OTHERWISE SPECIFIED.
 - BRINE TANK MUST BE LOCATED WITHIN 10 FEET OF SYSTEM CONTROL VALVE AND ON A COMMON FLOOR ELEVATION WITH MINERAL TANK TO ENSURE PROPER BRINE DRAW OPERATION.
 - USE FACTORY SUPPLIED BRINE TUBING. DO NOT USE SMALLER DIAMETER TUBING THAN WHAT IS SUPPLIED.
 - LIMIT INLET PRESSURE TO NOT EXCEED MAXIMUM PUBLISHED OPERATING PRESSURE.

SERIES CWSTA-200 DUPLEX ALTERNATING DIMENSION (INCHES) & SPECIFICATIONS

MODEL NO.	ORDERING CODES (EDP NO.)	MINERAL TANK SIZE	INLET	OUTLET	OVERALL HEIGHT (SEE NOTE 5)	OVERALL DEPTH	OVERALL WIDTH	MINIMUM INLET PIPE DISTANCE	BRINE TANK (SEE NOTE 9)	CONTROL VALVE INLET/OUTLET PIPE SIZE (NPT)	DRAIN CONN. SIZE (NPT)	SERVICE FLOW GPM @ 15 PSI DROP	PEAK SERVICE FLOW GPM @ 25 PSI DROP	DRAIN FLOW RATE (GPM)	MIN/MAX OPERATING TEMP F°	MIN/MAX OPERATING PRESSURE (PSI)	ESTIMATED OPERATING WEIGHT (LBS)	ESTIMATED SHIPPING WEIGHT (LBS)
M4543WTA	68109904	14 X 65	68.5	68.5	74.3	15	60	3.5	18 X 40	2.0	1.0	39	50	5	34/110	25/125	1298	530
M4547WTA	68109905	16 X 65	68.5	68.5	74.3	16	60	5.5	18 X 40	2.0	1.0	47	60	7	34/110	25/125	1472	700
M4548WTA	68109906	18 X 65	68.5	68.5	74.3	18	70	7.5	24 X 41	2.0	1.0	53	69	10	34/110	25/125	2153	800
M4552WTA	68109907	21 X 62	65.5	65.5	73.0	21	75	10.5	24 X 50	2.0	1.0	66	85	13	34/110	25/125	2996	1200
M4558WTA	68109908	24 X 72	75.5	75.5	83.0	24	87	13.5	30 X 50	2.0	1.0	73	94	15	34/110	25/125	4156	1420
M4559WTA	68109909	30 X 72	75.5	75.5	83.0	30	104	16.5	39 X 48	2.0	1.0	84	109	25	34/110	25/125	6489	2320
M4560WTA	68109910	36 X 72	75.5	75.5	83.0	36	115	22.5	39 X 48	2.0	1.0	93	119	35	34/110	25/125	8758	2840

WATTS 815 CHESTNUT ST. NORTH ANDOVER, MA 01845

THIS DRAWING DISCLOSES CONFIDENTIAL AND OTHER DATA OF A PROPRIETARY NATURE OWNED BY WATTS WATER TECHNOLOGIES, INC. AND MAY NOT BE USED OR DISCLOSED TO OTHERS WITHOUT THE PRIOR WRITTEN CONSENT OF WATTS WATER TECHNOLOGIES, INC.

DWG BY: DC DATE: 3/9/2023 SCALE: NTS SHEET: 1 OF 1 SUPERSEDES:

LIMITS UNLESS SPECIFIED: FRACTIONAL ANGULAR 1/16" 3/32" 1/8" 1/4" 3/8" 1/2" 5/8" 3/4" 1" 1 1/4" 1 1/2" 2" 2 1/2" 3" 4" 6" 8" 12" 18" 24" 30" 36" 48" 60" 72" 96" 120" 144" 180" 240" 300" 360" 480" 600" 720" 960" 1200" SURFACE FINISH: 125 RMS 150 RMS 180 RMS 200 RMS 250 RMS 300 RMS 360 RMS 450 RMS 600 RMS 800 RMS 1000 RMS DO NOT SCALE DRAWING

TITLE: GENERAL INSTALLATION, SERIES CWSTA-200 DUPLEX ALTERNATING 2.0" WATER SOFTENERS

MATERIAL: N/A

OTHER: ESTIMATED WEIGHT: SEE TABLE

PART NO.: SEE TABLE

EDP NO.: SEE TABLE

FILE TYPE: CAD

SIZE: D

REV: 1

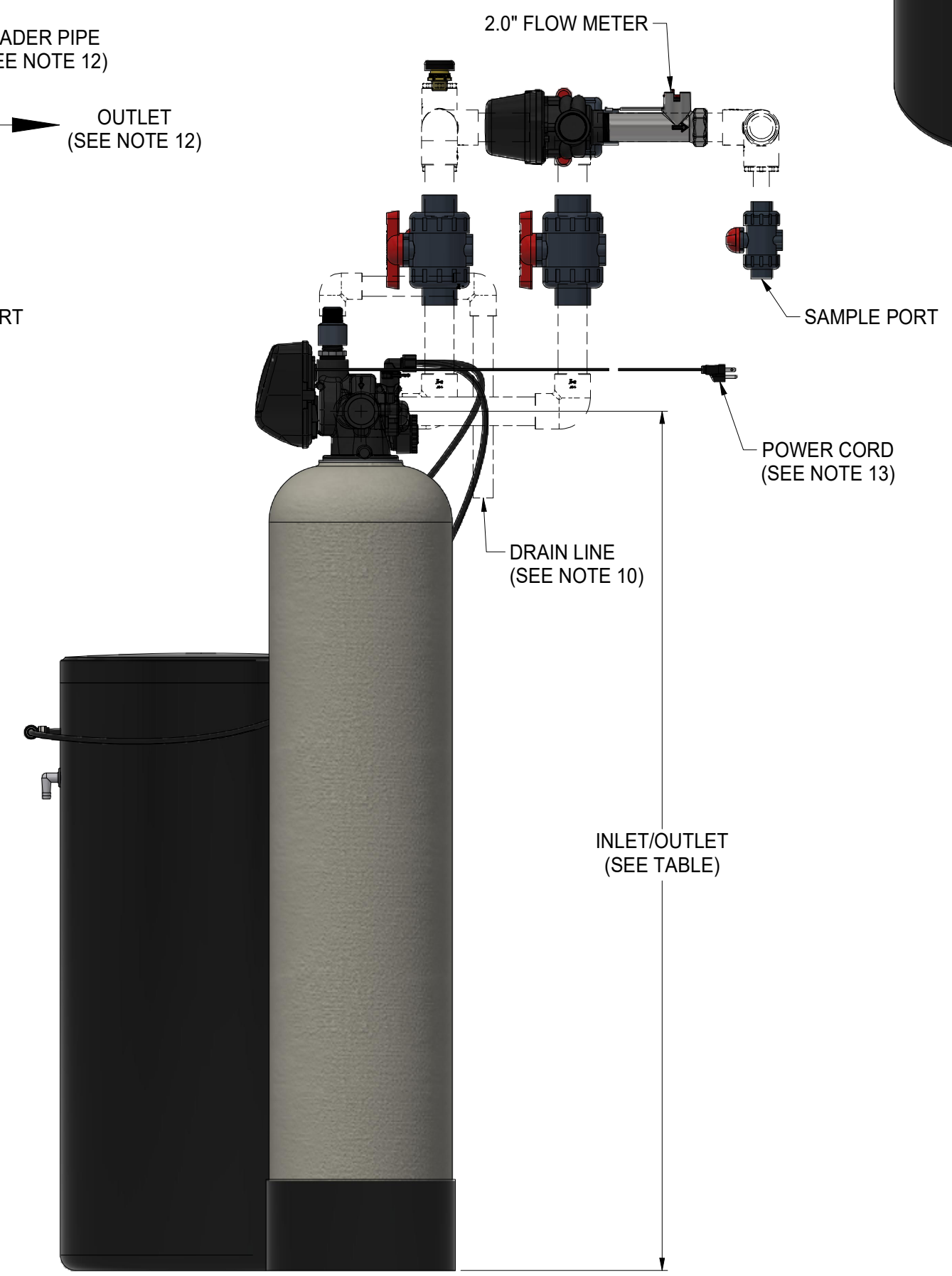
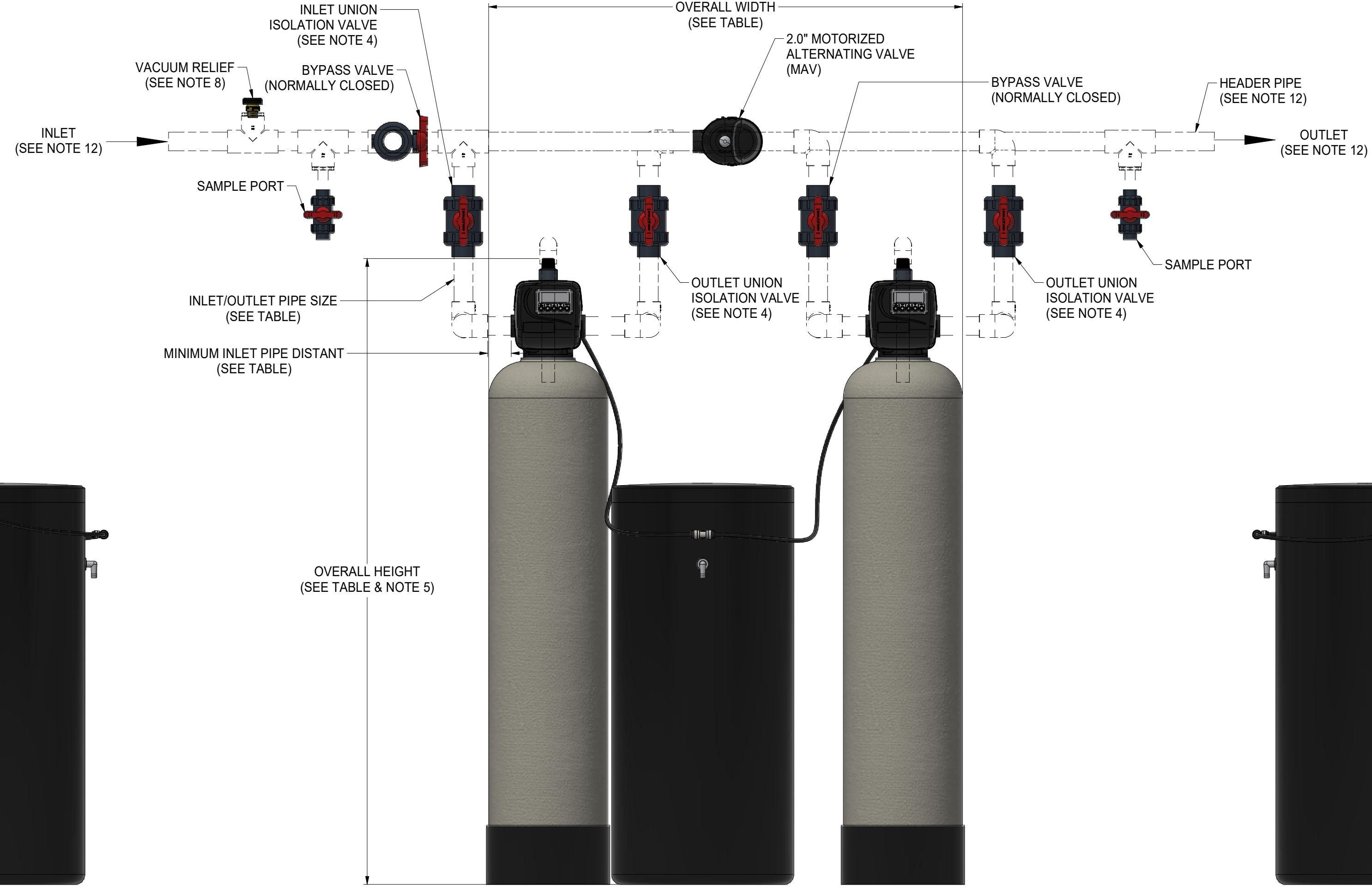
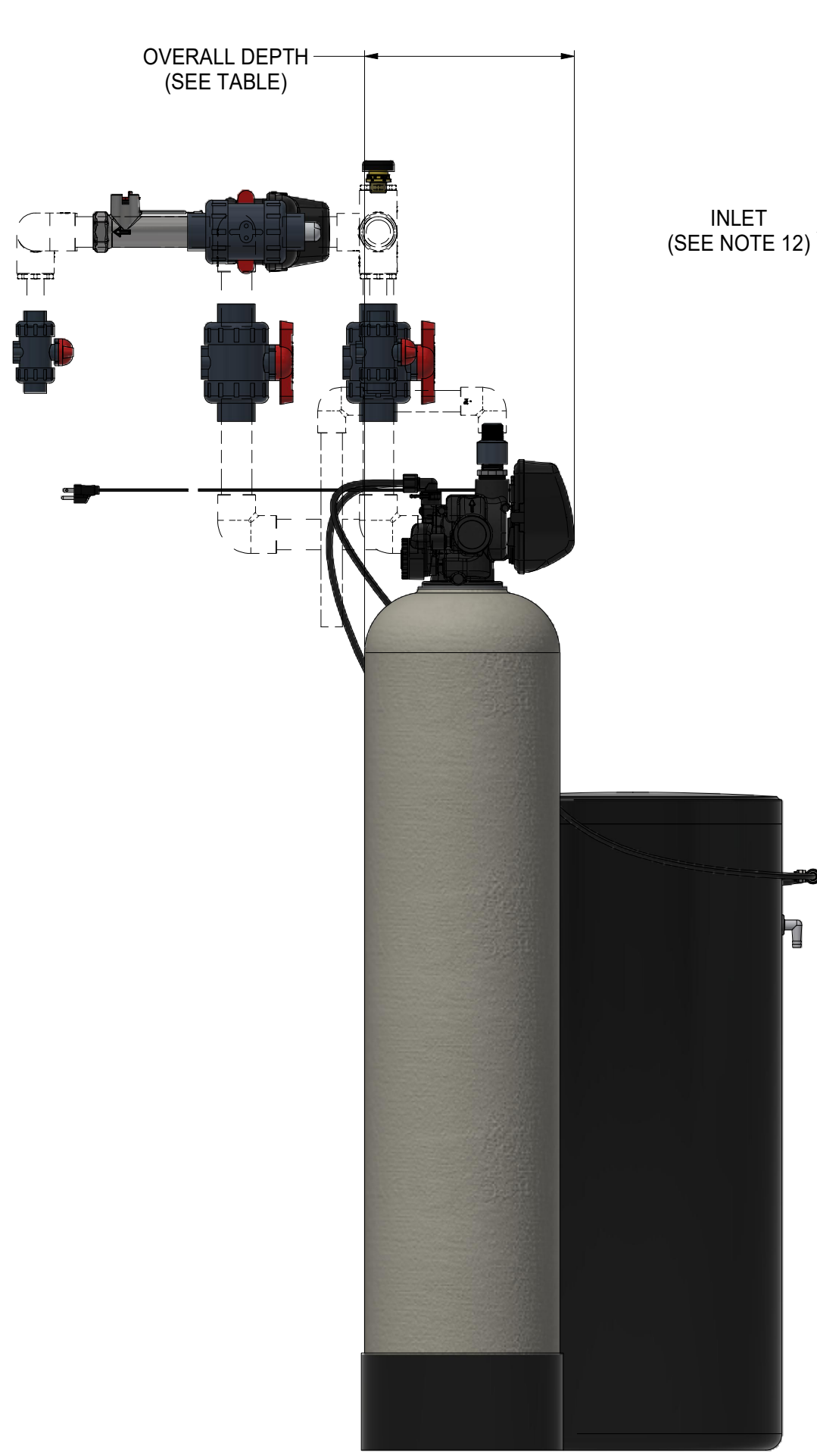
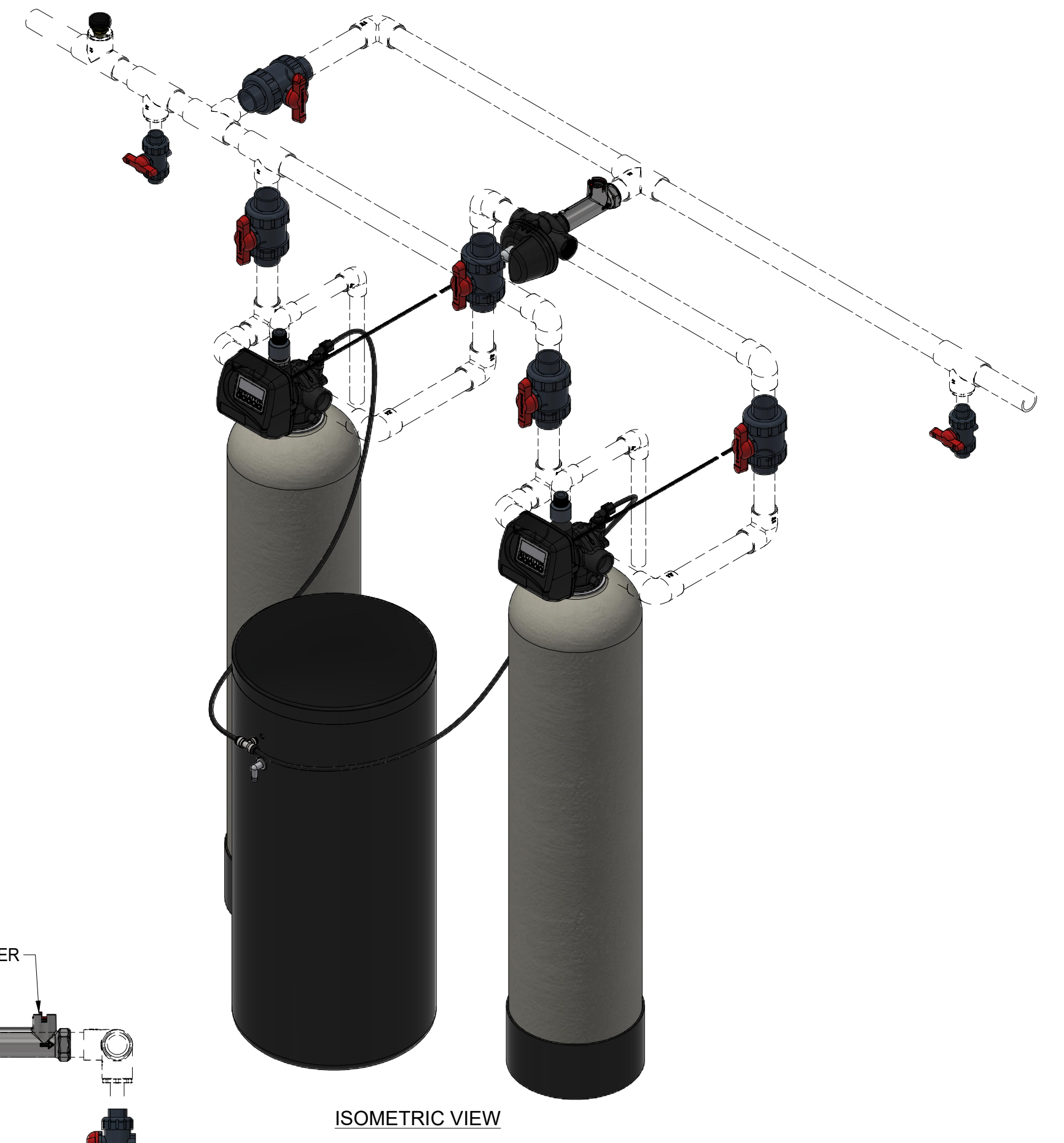
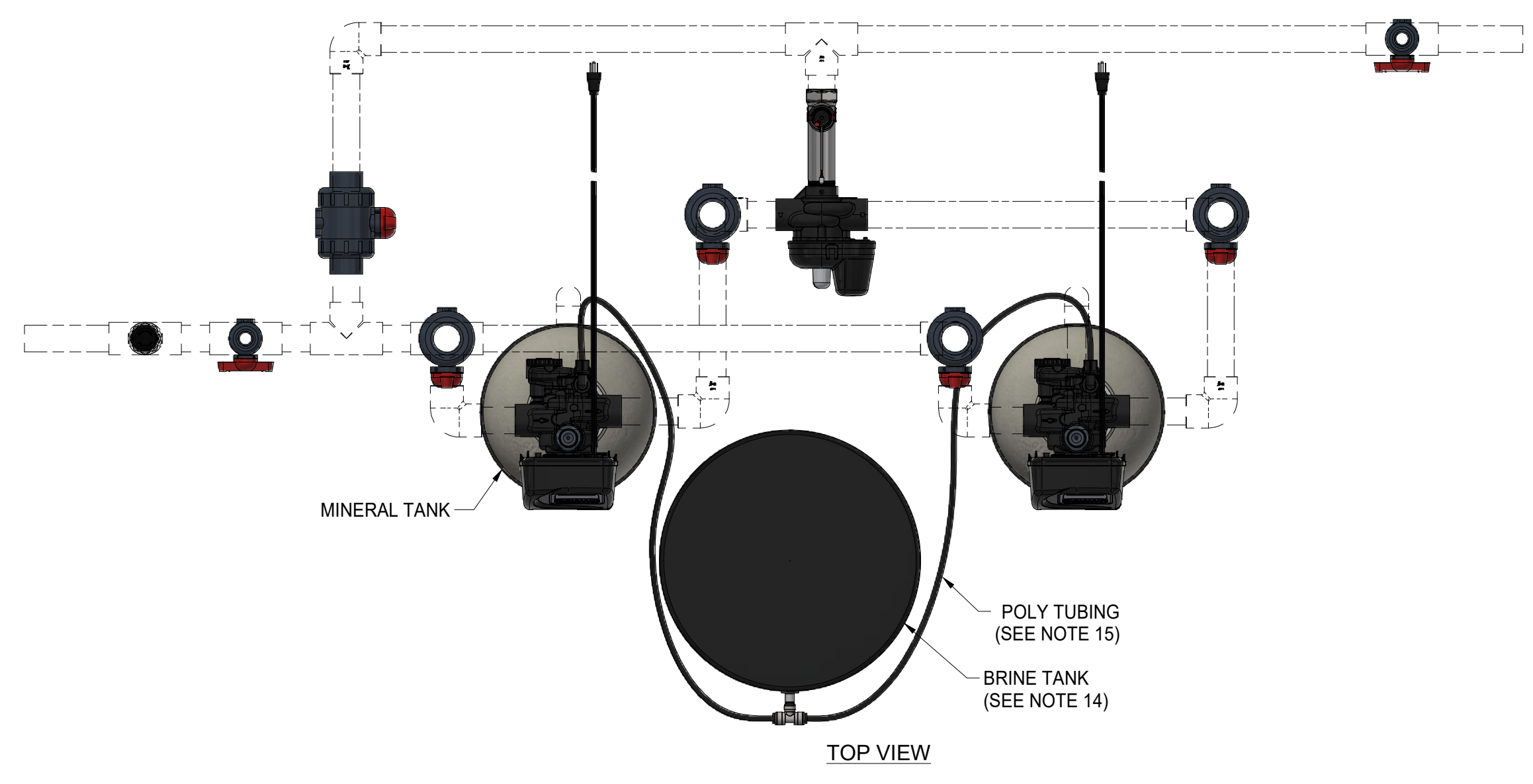

CLIENT PROJECT SIGN-OFF

JOB NAME: _____

JOB LOCATION: _____

CONTRACTOR: _____

CONTRACTOR APPROVAL: _____

CONTRACTOR APPROVAL DATE: _____

CONTRACTOR PO NO: _____

ENGINEER: _____

ENGINEER APPROVAL: _____

ENGINEER APPROVAL DATE: _____