

Engineering Specification

Job Name _____

Contractor _____

Job Location _____

Approval _____

Engineer _____

Contractor's P.O. No. _____

Approval _____

Representative _____

LEAD FREE*

MasterSeries® LF886V Reduced Pressure Zone Detector Backflow Prevention Assembly (Type II)

2½" – 10"

MasterSeries LF886V Reduced Pressure Zone Detector assembly is designed to protect against backpressure and backsiphonage conditions for high hazard/toxic application in accordance with Local Governing Water Utility Codes. Used primarily on potable drinking water systems where Local Governing Code mandates protection from non-potable quality water being pumped or siphoned back into the potable water system.

The ductile iron body is fused with ArmorTek® technology to resist corrosion due to microbial induced corrosion (MIC) or exposed metal substrate. The series features Lead Free construction to comply with low lead installation requirements. The Lead Free Reduced Pressure Zone Detector assemblies shall comply with state codes and standards, where applicable, requiring reduced lead content.

The series include a flood sensor to detect excessive water discharges from the relief valve. The flood sensor relays a signal that triggers a multichannel alert (call, email, text) to notify personnel about potential flooding.

NOTICE

An add-on connection kit is required to activate the flood sensor. Without the connection kit, the flood sensor is a passive component that does not communicate with any other device. (A retrofit sensor connection kit is also available for existing installations. For more information, download RP/IS-F-880V-RP/RPDA.)

NOTICE

Use of the flood sensor does not replace the need to comply with all required instructions, codes, and regulations related to installation, operation, and maintenance of this product, including the need to provide proper drainage in the event of a discharge.

Watts® is not responsible for the failure of alerts due to connectivity issues, power outages, or improper installation.

NOTICE

The information contained herein is not intended to replace the full product installation and safety information available or the experience of a trained product installer. You are required to thoroughly read all installation instructions and product safety information before beginning the installation of this product.

Inquire with governing authorities for local installation requirements.



LF886V-OSY with flood sensor

Features

Main Valve:

- Stainless steel relief valve seat and stainless steel check components for maximum performance and durability
- Inline serviceable assembly
- No special tools required for servicing
- Captured modular spring assembly
- Reversible and replaceable discs
- Field replaceable seats
- Ductile iron valve body design
- Advanced ArmorTek coating technology to resist corrosion of internals
- Modular and repairable pressure differential relief valve
- Clapper check assembly
- Captured O-ring design
- Sensor on relief valve for flood detection, activated by add-on connection kit for BMS or cellular network communication

Auxiliary Bypass:

- Compact bypass design; remains in main valve assembly profile
- Inline serviceable ¾" check assembly
- No special tools required for servicing
- Field replaceable seat and disc
- Detect potential underground water leaks
- Detect unauthorized water usage

*The wetted surface of this product contacted by consumable water contains less than 0.25% of lead by weight.



A WATTS Brand

Specification

FEBCO MasterSeries LF886V Reduced Pressure Zone Detector assembly shall be installed on the potable water supply and at each point of cross-connection to protect against possible backpressure and backsiphonage conditions for high hazard/toxic applications. The assembly shall consist of a main line valve body composed of two (2) independently acting approved clapper style check modules with replaceable seats and disc rubbers. Servicing of both check modules does not require any special tools and are accessed through independent top entry covers. This assembly shall be fitted with UL Classified and FM Approved inlet/outlet resilient seated shutoff valves and contain four (4) properly located resilient seated test cocks as specified by AWWA Standard C511. The auxiliary bypass line contains a 5/8" x 3/4" Water Meter that complies with ANSI/AWWA Standard C700 coupled with an approved check assembly compliant to AWWA Standard C511. The bypass line is designed to detect leaks or unauthorized water usage of the water system while protecting against possible backpressure and backsiphonage conditions for high hazard/toxic applications. The valve body shall incorporate a coating system with built-in electrochemical corrosion inhibitor and microbial inhibitor. Flow and pressure loss performance parameters shall meet the requirements of AWWA Standard C511. The assembly shall be FEBCO MasterSeries LF886V and shall include a sensor on the relief valve for flood detection.

Model/Option

| | |
|-----|---|
| FS | Sensor on relief valve for flood detection |
| OSY | UL Classified and FM Approved OS&Y gate valves (ANSI/AWWA C515 Compliant) |
| CFM | Totalizing cubic ft/min 5/8"x 3/4" water meter (ANSI/AWWA C700 Compliant) |
| GPM | Totalizing gal/min 5/8"x 3/4" water meter (ANSI/AWWA C700 Compliant) |
| LG | Less shutoff valves (This is NOT an APPROVED ASSEMBLY.) |

Example Ordering Descriptions

4" LF886V-OSY-GPM-FS - Valve assembly fitted OS&Y shutoff valves, gallons per minute water meter, and flood sensor

4" LF886V-OSY-CPM-FS - Valve assembly fitted OS&Y shutoff valves, cubic meter per minute water meter, and flood sensor

Available Components

| | |
|-------------------------|--|
| Wye Strainer | FDA Approved (ASME B16.1 Class 125 & AWWA Class D Flange) |
| Series 611 Valve Setter | MJ x MJ - Mechanical Joint x Mechanical Joint (AWWA C111/A21.11) MJ x FL - Mechanical Joint x Flange (AWWA C111/A21.11; ASME B16.1 Class 125/AWWA Class D Flange) FL x FL – Flange x Flange (ASME B16.1 Class 125 & AWWA Class D Flange) |

Approvals – Standards

- Foundation for Cross-Connection Control and Hydraulic Research at The University of Southern California (FCCCHR-USC)
- ASSE 1047
- UL Classified** (US & Canada)
- FM Approved**
- IAPMO/cUPC
- AWWA Standard C511 Compliant
- End Connections: Compliant to ASME B16.1 Class 125 & AWWA Class D Flange



Assembly Flow Orientation

Horizontal (N-Pattern 2½" – 10") - Approved by FCCCHR-USC, ASSE, cULus, FM, IAPMO/cUPC

Vertical Up (Z-Pattern 2½" – 10") - Approved by FCCCHR-USC, ASSE, cULus, FM, IAPMO/cUPC

**Assembly configured with UL Classified and FM Approved OS&Y RW gate valves. Less gate valve assemblies are not UL Classified and FM Approved configurations.

Materials

All assemblies (sizes 2½" to 10") are similar in materials and construction. Contact your local FEBCO representative if you require further information.

| | |
|-------------------|--|
| Main Valve Body | Ductile iron Grade 65-45-12 |
| Relief Valve Body | Ductile iron Grade 65-45-12 |
| Coating | Fusion epoxy coated internal and external AWWA C550-90 |
| Shutoff Valves | OSY resilient wedge gate valve AWWA C515 (UL Classified and FM Approved) |
| Check Seats | Stainless steel |
| Relief Valve Seat | Stainless steel |
| Disc Holder | Stainless steel |
| Elastomer Disc | Silicone |
| Spring | Stainless steel |
| Clamp | AWWA C606 |

Pressure - Temperature

| | |
|-----------------------------|--|
| Max. Working Pressure | 175 psi (12.1 bar) |
| Min. Working Pressure | 20 psi (1.4 bar) |
| Hydrostatic Test Pressure | 350 psi (24.1 bar) |
| Hydrostatic Safety Pressure | 700 psi (48.3 bar) |
| Temperature Range | 33°F – 140°F (0.5°C – 60°C) continuous |

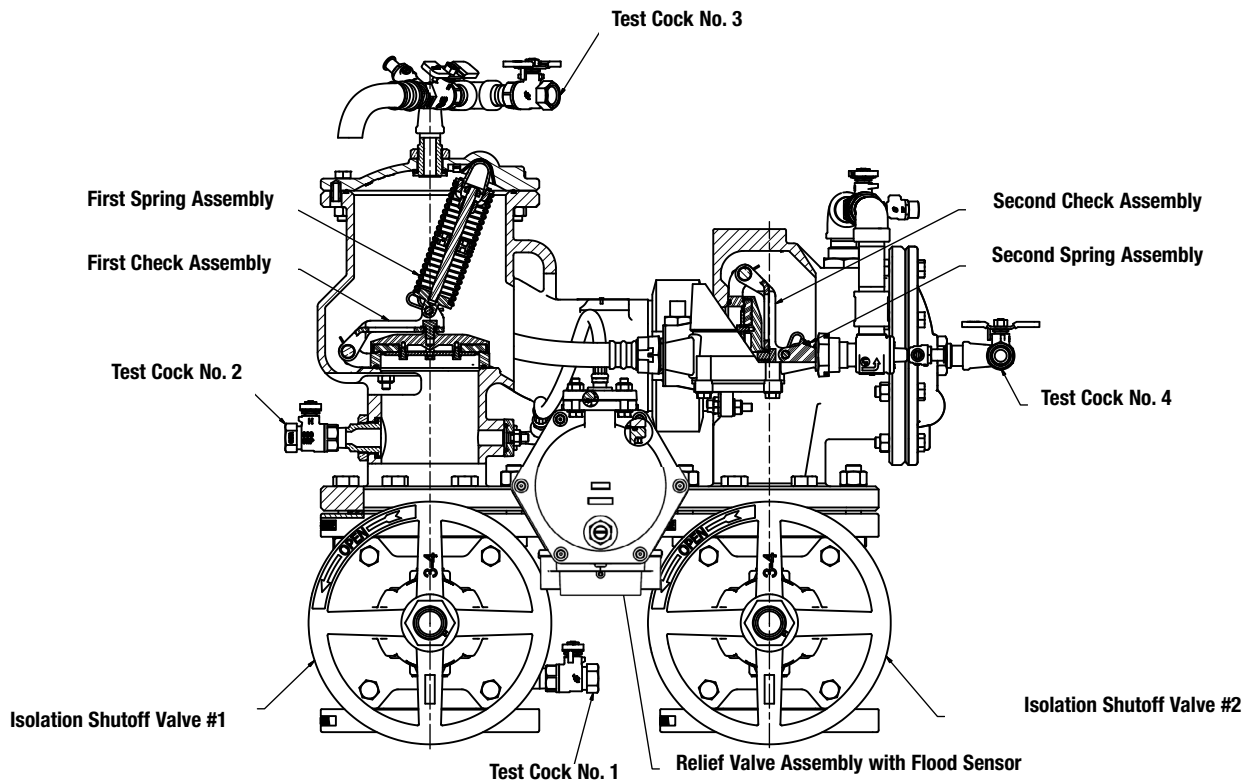

Dimensions and Weights

Below are the nominal dimensions and physical weights for LF886V, sizes 2½" to 10". Allowances must be made for normal manufacturing tolerances. Download installation instructions at watts.com, or contact your local FEBCO representative for more information.

Standard (N-pattern) Orientation

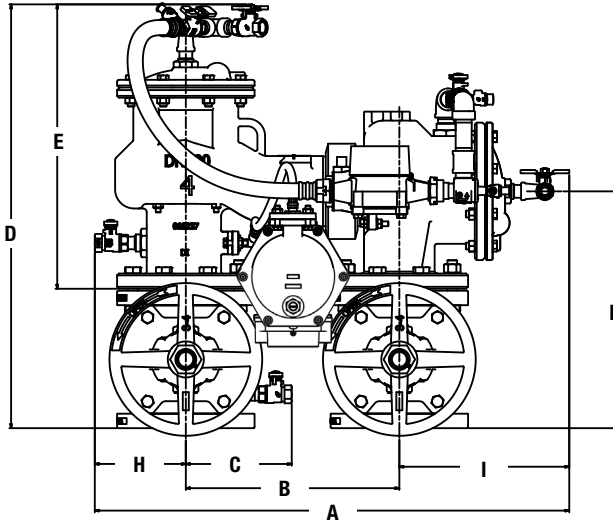

Vertical (Z-pattern) Orientation

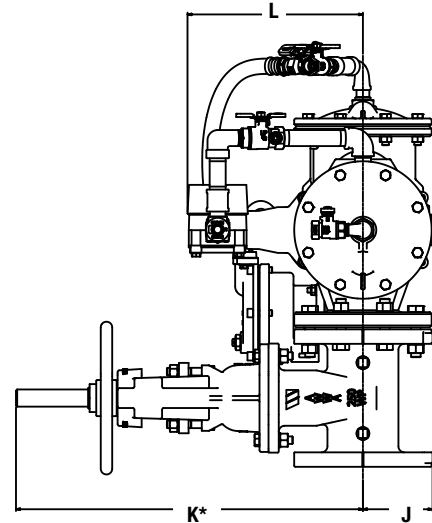
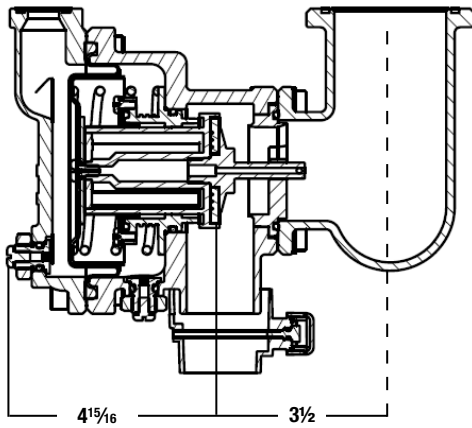
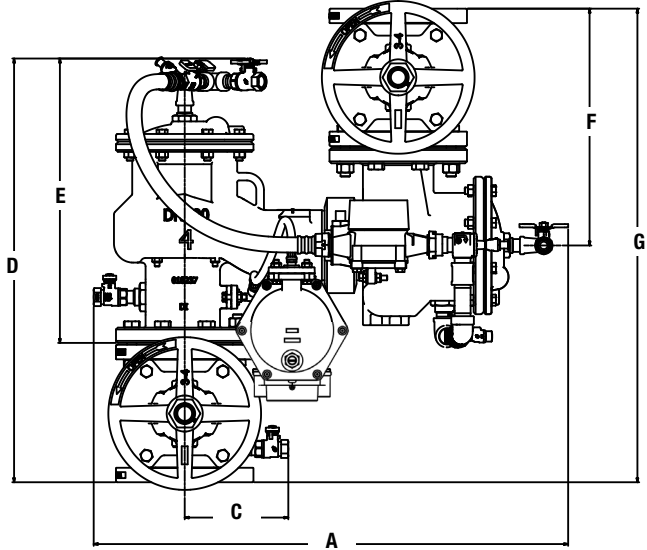

Call customer service if you need assistance with technical details.

| SIZE | DIMENSIONS | | | | | | | | | | | | | | WEIGHT** | | | | | | | | | | | |
|------|------------|------|-----|-----|-----|-----|-----|------|-----|-----|-----|-----|-----|------|----------|-----|-----|-----|-----|-----|-----|------|-----|-----|------|-----|
| | A | | B | | C | | D | | E | | F | | G | | H | | I | | J | | K* | | L | | OSY | |
| in. | in. | mm | in. | mm | in. | mm | in. | mm | in. | mm | in. | mm | in. | mm | in. | mm | in. | mm | in. | mm | in. | mm | in. | mm | lb | kg |
| 2½ | 29⅞ | 740 | 12½ | 318 | 6¼ | 159 | 25¼ | 642 | 17½ | 445 | 13⅝ | 346 | 27¼ | 692 | 5½ | 140 | 11⅞ | 283 | 3½ | 89 | 16⅞ | 416 | 11½ | 292 | 240 | 109 |
| 3 | 29⅞ | 740 | 12½ | 318 | 6¼ | 159 | 25¼ | 654 | 17¾ | 451 | 14⅞ | 359 | 28¼ | 718 | 5½ | 140 | 11⅞ | 283 | 3¾ | 95 | 22¼ | 565 | 11½ | 292 | 267 | 121 |
| 4 | 31⅞ | 791 | 14 | 356 | 7 | 178 | 27¾ | 705 | 18¾ | 476 | 15½ | 394 | 31 | 787 | 6 | 152 | 11⅞ | 283 | 4½ | 114 | 23¼ | 591 | 13 | 330 | 342 | 155 |
| 6 | 35¼ | 908 | 16 | 406 | 8 | 203 | 32¼ | 831 | 22⅞ | 562 | 18⅞ | 473 | 37¼ | 946 | 7¼ | 184 | 12½ | 316 | 5½ | 140 | 30⅞ | 765 | 13 | 330 | 530 | 240 |
| 8 | 40¼ | 1035 | 18½ | 470 | 9¼ | 235 | 36¼ | 933 | 25⅞ | 638 | 20¾ | 527 | 41½ | 1054 | 8½ | 216 | 14 | 356 | 6¾ | 172 | 37¼ | 959 | 14½ | 368 | 846 | 384 |
| 10 | 46¼ | 1175 | 21 | 533 | 10⅞ | 264 | 41⅞ | 1047 | 28⅞ | 714 | 23⅞ | 601 | 47⅞ | 1202 | 9⅞ | 244 | 15⅞ | 398 | 8 | 203 | 45¼ | 1162 | 13⅞ | 333 | 1363 | 618 |

* Indicates nominal dimensions with OSY gate valves (full open positions).

** Indicates weight of complete backflow assemblies with specified gate valves.

The gap drain is not designed to catch the maximum discharge possible from the relief valve. The installation of the FEBCO air gap with the drain line terminating above a floor drain handles any normal discharge or nuisance spitting through the relief valve. However, floor drain size may need to be designed to prevent water damage caused by a complete failure condition. Do not reduce the size of the drain line from the air gap fitting.

Performance

The flow capacity chart identifies valve performance based upon rated water velocity up to 20 fps.

- Maximum service flow rate is determined by maximum rated velocity of 7.5 fps.
- AWWA Manual M-22 (Appendix C) recommends that the maximum water velocity in the services be not more than 10 fps.
- UL flow rate is determined by typically rated velocity of 15 ft/s.

Capacity

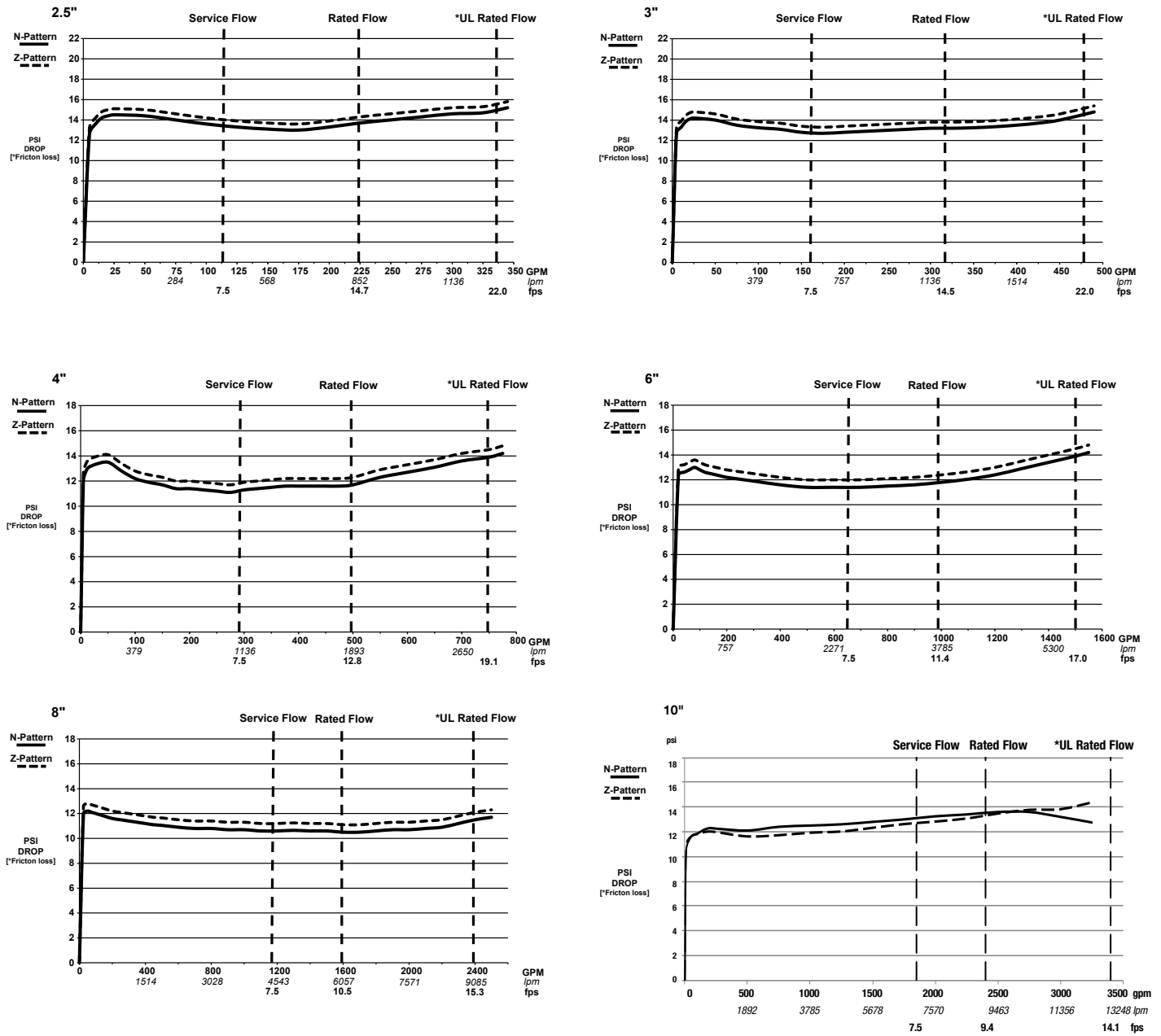

A WATTS Brand

USA: T: (800) 767-1234 • FEBCOonline.com
 Canada: T: (888) 208-8927 • FEBCOonline.ca
 Latin America: T: (52) 55-4122-0138 • FEBCOonline.com