

Innovation Water Heater Management



System Efficiency for Domestic Hot Water from the leader in Condensing Firtube Designs.

The AERCO Innovation line of high performance commercial tankless water heaters features Water Heater Management (WHM) standard onboard the Edge [i] Controller. WHM is the only sequencing control that truly addresses two key water heating system performance issues: cycling and standby losses. This feature guarantees that an installed system of multiple Innovation heaters:

- Optimizes operating efficiencies at all load conditions
- Virtually eliminates standby losses
- Increases system reliability through reduced cycling
- Accurately tracks daily domestic hot water demands

Available in four sizes (625, 800, 1060 and 1350 MBH), Innovation features advanced modulating technology and is a thermal shock-proof, firetube heat exchanger that is highly resistant to scale build-up. The Innovation provides hot water on demand without the need for any storage. Thanks to its unique tankless design, the Innovation is highly space-efficient and cost-effective, as it eliminates the need for significant storage volume to buffer load change and provide stable hot water outlet temperatures, which tank-type heaters require.

Features

- Minimizes energy costs
- Tight temperature control at all loads ($\pm 4^{\circ}\text{F}$)
- NSF 372 compliant
- Easier installation through a standard doorway due to smaller footprint and unmatched venting flexibility
- Reduced cycling losses due to unmatched turndown and onboard multi-unit sequencing
- Low NOx and low CO emissions
- Over 66% less standby losses than condensing tank type heaters
- Enhanced occupant safety – active exhaust temperature monitoring for PVC flue protection
- Designed and manufactured in the USA

Each size features precise temperature control and load tracking down to 50 MBH - minimizing cycling losses and heater wear and tear.

INN 600N @ 12:1 Turndown

INN 1060N @ 21:1 Turndown

INN 800N @ 16:1 Turndown

INN 1350N @ 27:1 Turndown

25+ years of experience with high efficiency condensing boilers and water heaters has enabled us to create the industry's first effective water heater sequencing system.

The onboard robust logic is designed to efficiently sequence up to 16 water heaters on the same system to meet load requirements and minimize cycling and stand-by losses, of utmost importance with domestic hot water. It optimizes system efficiency and load tracking, and balances unit run hours to significantly reduce service and maintenance costs. With this unique feature, the operating system turndown will equal the individual unit turndown multiplied by the number of units employed. Hence an application using six INN 1350N's @ 27:1 will modulate to meet system load with a total turndown of over 160:1.



The Manager Edge [i] operates one motorized valve per unit as an element of the load sequencing. The WHM sequencing logic also incorporates a unique manager/client backup feature that provides automatic bumpless transfer of manager functions to the next unit on the chain, in case of designated manager unit shutdown.

The system works as follows:

- Low / no hot water demand - Lead heater on with its motorized sequencing valve open
- Hot water demand increases - WHM opens more sequencing valves to engage more heaters
- Hot water demand decreases - WHM closes sequencing valves of unneeded water heaters
- WHM maintains lead at set point / sequencing valve open to support fast response and the building recirculation requirement

WHM is designed to make sure that all water heaters in the system operate at maximum efficiency. It monitors the fire rate of all water heaters sequences them by opening or closing the motorized valve as required to meet hot water demand.

The manager decides which unit to enable or disable based on run hours and as a result of this logic, the manager effectively balances run hours evenly amongst all the units. When a unit is disabled, the small volume of water held in the shell is allowed to drop to ambient temperature. This is done to ensure that the disabled unit does not cycle needlessly to maintain set point and to minimize system radiation losses. Since each Innovation is equipped with a small feed-forward circulator, constant flow is maintained in the disabled unit alleviating any concern over Legionella bacteria growth. A brief time-delay has been programmed into the sequencing logic to allow a disabled unit to fire back up to set point prior to the valve opening.

The result is the most energy efficient and reliable water heating system design available. Only those units required to meet load are operating. Units in standby do not needlessly cycle to maintain set point - reducing system standby losses and unit wear to the bare minimum. Compared to a conventional storage system which requires 125 gallons of storage for every 500 MBH input, an Innovation system truly provides reliable domestic hot water on demand in the smallest possible energy footprint.

The following chart illustrates how multiple Innovation heaters with WHM compare with the two most common alternative system designs: 1) storage tank heaters and 2) hot water supply boilers packaged with external storage tanks.



Valve Packaged on the Innovation Unit

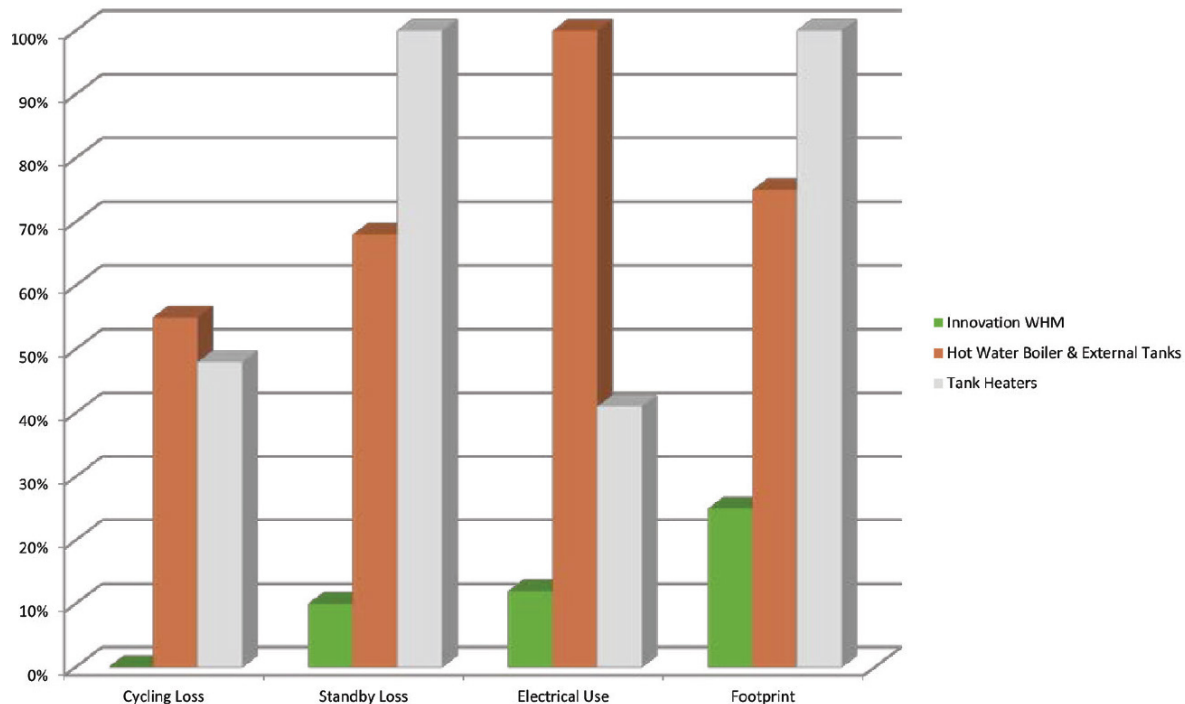

Innovation water heaters with WHM deliver:

- Optimized operating efficiencies with virtually no cycling and standby losses
- Smallest physical and energy footprint vs. any competitive alternative

Dimensions

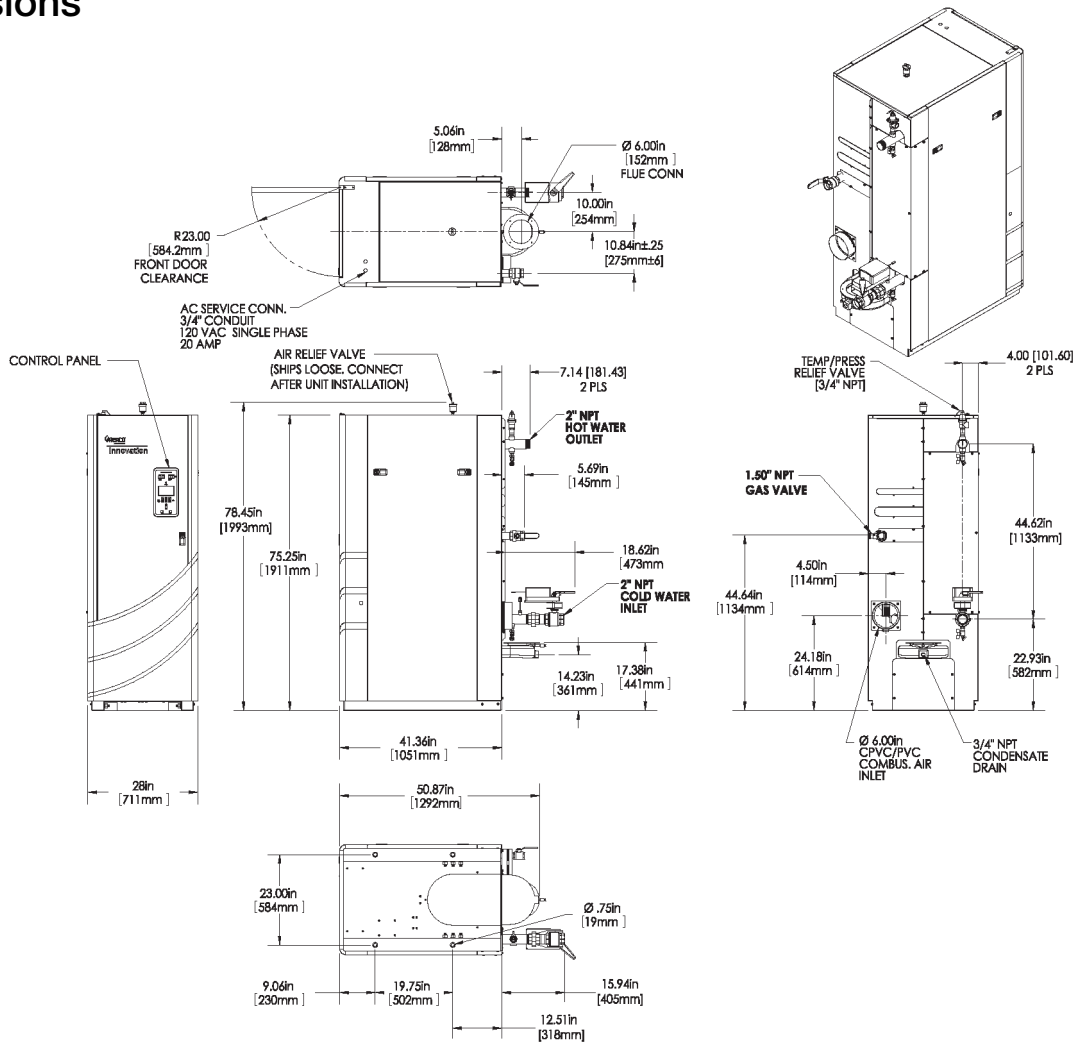

Specifications

Adjustable Temperature Control: 50°F to 190°F
 Ambient Temperature: 0°F to 130°F
 Accuracy: ±4°F
 Turndown Ratio: Up to 27:1
 Flue Size: 6" Diameter
 Flue Material (per local code): PVC, CPVC, PP or AL29-4C
 Water Inlet and Outlet: 2" NPT Male
 Gas Connection: 1.5" NPT Male Nat. Gas
 Gas Pressure Requirements: 14" WC Maximum
 4" WC Minimum @ Full Load (Nat. Gas)

Maximum Continuous Water Flow: 50 GPM
 Condensate Connection: 3/4" NPT Female
 Maximum Condensate Flow: 11 GPH
 Pressure Rating: 160 PSIG @ 210°F
 NOx Emission Certifications: SCAQMD, TCEQ
 Standard Listing and Approvals: UL, cUL, ASME, (HLW)
 Gas Train Options: FM Compliant
 Electrical Requirements: 120/1/60 20 AMP (9 Amp FLA)
 Water Pressure Drop @ 20 gpm: 1.5 psi
 Water Pressure Drop @ 30 gpm: 2 psi



Heating and Hot Water Solutions

AERCO International, Inc. • 100 Oritani Drive • Blauvelt, NY 10913
 USA: T: (845) 580-8000 • Toll Free: (800) 526-0288 • AERCO.com