

Installation, Operation & Maintenance Manual

Maxim 3 Water Heater

Models: (100, 150, 180, 200) L (125, 300) A-MXIF

Warning: If the information in these instructions is not followed exactly, a fire or explosion may result causing property damage, personal injury or death. Do not store or use gasoline or other flammable vapors and liquids in the vicinity of this or any other appliance.

What to do if you smell gas:

- Do not try to light any appliance.
- Do not touch any electrical switch; do not use any phone in your building.
- Immediately call your gas supplier from a neighbor's phone. Follow the gas supplier's instructions.
- If you cannot reach your gas supplier, call the fire department.

Important: This manual contains information required for installation, operation and maintenance of this equipment. Read and follow the information in this manual and all other provided instructions, labels and markings before installing, operating or servicing this unit.

Installation and service must be performed by a qualified service installer, service agency or the gas supplier.



To the installer: After installation, these instructions must be given to the equipment user or left near the appliance.

Special instructions to the owner: Retain this manual for future reference. These instructions contain important information that will help you in maintaining and operating this appliance.



Manufacturing ASME Commercial Water Heaters Since 1961

MAXIM 3 WATER HEATER

TABLE OF CONTENTS

- 1. Safety Considerations**
- 2. Product Description**
- 3. Water Heater Installation**
 - 3.1 Checking Equipment Before You Install
 - 3.2 Codes
 - 3.3 Electrical Requirements
 - 3.4 Handling and Locating the Water Heater
 - 3.5 Clearances to Combustible Surfaces
 - 3.6 Service Clearances
 - 3.7 Other Code and Regulatory Clearances and Requirements
- 4. General Piping Guidelines**
 - 4.1 Inlet and Outlet Connections
 - 4.2 Building Return Piping
- 5. Gas Supply and Piping**
 - 5.1 Gas Train and Controls Certification
 - 5.2 Gas Control Train
 - 5.3 Inlet Pressure
 - 5.4 Manifold Pressure
 - 5.5 Gas Piping Size
 - 5.6 Appliance Isolation during Gas Supply Piping Pressure Test
 - 5.7 Gas Connection
- 6. Combustion and Ventilation Air**
 - 6.1 Equipment Located in Confined Spaces
 - 6.2 Maximum Allowed Remote Combustion Air Inlet Length
 - 6.3 Remote Combustion Air Cap
 - 6.4 Vertical or Horizontal Remote Air Duct Termination
 - 6.5 Combining Remote Air Ducting
- 7. Venting**
 - 7.1 Venting the Unit Using Category I, III or IV Venting Materials
 - 7.2 Category I Venting
 - 7.3 Category III or IV Venting
 - 7.3.1 Maximum Category III or Category IV Vent Length
 - 7.3.2 Vertical or Horizontal Vent Termination
 - 7.3.3 Combining Category III or Category IV Vents
- 8. Operating and Safety Controls**
 - 8.1 Temperature and Pressure Relief Valve(s)
 - 8.2 Cathodic Protection
 - 8.3 Electronic Low Water Cut-off (optional)
 - 8.4 Operating Temperature Control
 - 8.5 High Water Temperature Limit Control

MAXIM 3 WATER HEATER

- 9. TEMPTRAC Electronic Controller Panel**
 - 9.1 Principal of Operation
 - 9.2 Lower LED Readout
 - 9.3 Upper LED Readout
 - 9.4 Control Buttons
 - 9.5 To View the Setpoint
 - 9.6 To Change the Setpoint
 - 9.7 To Change Other Parameters
 - 9.8 LED Display Alarm Messages
 - 9.9 LED Icon Legend
- 10. Remote Connections – Terminal Strip**
 - 10.1 Making BMS/BAS Remote Connection for Analog and Binary Signals
 - 10.2 Terminal Functions
- 11. Sequence of Operation**
- 12. Initial Startup**
 - 12.1 Initial Startup Requirements
 - 12.2 Tools and Instrumentation Required
 - 12.3 Resources
 - 12.4 On Site Considerations
 - 12.5 Startup Procedure
- 13. Troubleshooting Guide**
 - 13.1 Troubleshooting Guide to be used with Wiring Diagram
- 14. Replacement Parts**
 - 14.1 Control Panel
 - 14.2 Control Panel Components
 - 14.3 Burner Assembly
 - 14.4 Burner Assembly Components
- 15. Periodic Maintenance**
- 16. Recommended Maintenance Schedule**

Warranty forms ship separately with each product.

MAXIM 3 WATER HEATER

1 SAFETY CONSIDERATIONS

WARNING: If the information in the supplied manual(s) is not followed exactly, a fire, explosion or exposure to hazardous materials may result, causing property damage, personal injury or death.

AVERTISSEMENT. Assurez-vous de bien suivre les instructions données dans cette notice pour réduire au minimum le risque d'incendie ou d'explosion ou pour éviter tout dommage matériel, toute blessure ou la mort.

FOR YOUR SAFETY

- **Do not** store or use gasoline or other flammable vapors or liquids in the vicinity of this or any other appliance.
- **Ne pas** entreposer ni utiliser d'essence ou ni d'autres vapeurs ou liquides inflammables à proximité de cet appareil ou de tout autre appareil.

WHAT TO DO IF YOU SMELL GAS

- **Do not** try to light any appliance.
- **Do not** touch any electric switch; do not use any phone in your building.
- **Immediately** call your gas supplier from a location away from your building and the smell of gas. Follow the gas supplier's instructions.
- If you cannot reach your gas supplier, call the fire department.

QUE FAIRE SI VOUS SENTEZ UNE ODEUR DE GAZ:

- Ne pas tenter d'allumer d'appareil.
- Ne touches à aucun interrupteur; ne pas vous servir des téléphones se trouvant dans le bâtiment.
- Appelez immédiatement votre fournisseur de gaz depuis un voisin. Suivez les instructions de fournisseur.
- Si vous ne pouvez rejoindre le fournisseur, appelez le service de incendies.

Installation and service must be performed by a qualified installer, service agency or the gas supplier.

L'installation et l'entretien doivent être assurés ou un service d'entretien qualifié ou par le fournisseur de gaz.

This product contains, or may come to contain materials that have been identified as carcinogenic, or possibly carcinogenic to humans. Before installing, servicing or removing this product, read and follow the supplied instructions

Clearance in accordance with the local installation codes and the requirements of the gas supplier.

Dégagement conforme aux codes d'installation locaux et aux exigences du fournisseur de gaz.

Should overheating occur or the gas supply fail to shut off, turn off the manual gas control valve to the appliance.

En cas de surchauffe ou si l'alimentation en gaz ne s'arrête pas, fermez manuellement le robinet d'arrêt de l'admission de gaz.

WARNING: Installation and service must be performed by a qualified installer, service agency or the gas supplier, who must read and follow the supplied instructions before installing, servicing or removing this appliance. Refer to the information contained in this manual. Improper installation, adjustment, alteration, service or maintenance can cause property damage, personal injury, exposure to hazardous materials or death.

WARNING: Do not use this appliance if any part has been under water. Immediately call a qualified service technician to inspect the unit and to replace any part of the control system, all gas controls and all other items affecting safe appliance operation and which has been under water.

AVERTISSEMENT: N'utilisez pas cet appareil s'il a été plongé dans l'eau, même partiellement. Faites inspecter l'appareil par un technicien qualifié et remplacez toute partie du système de contrôle et toute commande qui ont été plongés dans l'eau.

WARNING: In an emergency shut the main gas supply valve to the appliance from a location safely away from the emergency. Failure to follow these instructions can cause property damage, personal injury, and exposure to hazardous materials or death.

MAXIM 3 WATER HEATER

PRODUCT SAFETY INFORMATION REFRACTORY CERAMIC FIBER PRODUCT WITH CRYSTALLINE SILICA

WARNING: This product contains or may come to contain crystalline silica, which has been identified by the International Agency for Research on Cancer (IARC) as carcinogenic to humans. This product also contains refractory ceramic fibers, which have been identified by the IARC as possibly carcinogenic to humans. Avoid breathing fiber particulates and dust.

RISKS:

- Air borne fibrous insulation is a possible cancer hazard by inhalation.
- Airborne crystalline silica may cause silicosis (lung disease) by inhalation.
- May cause temporary irritation to eyes, skin, and respiratory tract.

PRECAUTIONARY MEASURES:

- Minimize airborne fibers with engineering controls.
- Use NIOSH/MSHA approved respirators as required (see SDS).
- Wear long sleeved, loose-fitting clothing, eye protection and gloves.

FIRST AID MEASURES: (If any of the irritations listed persists, seek medical attention)

- Eyes: Flush with water.
- Skin: Wash with soap and warm water.
- Ingestion: Do not induce vomiting. Get medical attention if gastrointestinal symptoms develop.
- Inhalation: Remove to fresh clean air.

WARNING: If you are unfamiliar with the safe handling of refractory ceramic fiber products, or if you wish additional information prior to beginning any disassembly of the water heater or boiler that might expose refractory ceramic fiber materials, contact: Unifrax Corporation, 2351 Whirlpool Street, Niagara Falls, NY 14305-2413, 1-800-322-2293.

IDENTIFICATION OF REFRACTORY CERAMIC FIBER MATERIALS (RCF):

The burner assembly utilizes RCF material. (The RCF materials are located within the product and not generally exposed except during service, disassembly or assembly.)

IMPORTANT SAFETY NOTE

It takes only 5 seconds of skin contact with 140°F water to cause a second degree burn! You must protect against high water temperatures at all lavatories, tubs, showers and other points of hot water contact.

Accidental scalding from high water temperatures is a greater risk in some types of installations. Some examples are:

**HOMES FOR THE MENTALLY HANDICAPPED
HOMES FOR THE PHYSICALLY HANDICAPPED
HOSPITALS AND NURSING HOMES
ELDER CARE FACILITIES AND REST HOMES
ORPHANAGES AND CHILD CARE FACILITIES**

OTHER INSTALLATIONS - WHERE RESPONSE TO CONTACT WITH HOT WATER MAY BE SLOWER OR WHERE THE DANGER OF HOT WATER CONTACT IS GREATER.

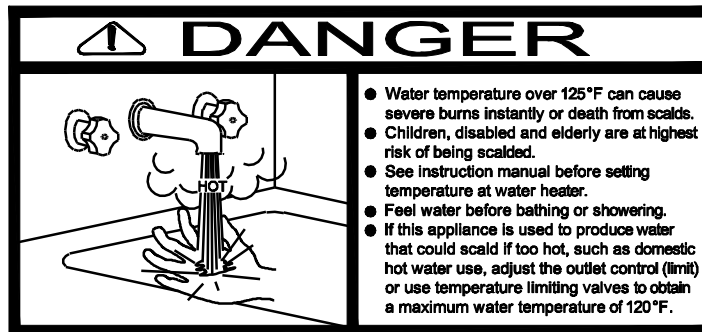

Thermostatically controlled mixing valves must be used in the design of the potable hot water system.

Potable hot water should be tempered to no more than 110°F when used for bathing or other personal uses.

Good engineering practice mandates the use of thermostatically controlled mixing valves set at 120°F or less to keep the delivered water temperature below scalding temperatures.

MAXIM 3 WATER HEATER

2 PRODUCT DESCRIPTION Component, Controls and Connection Locations (Locations May Vary)

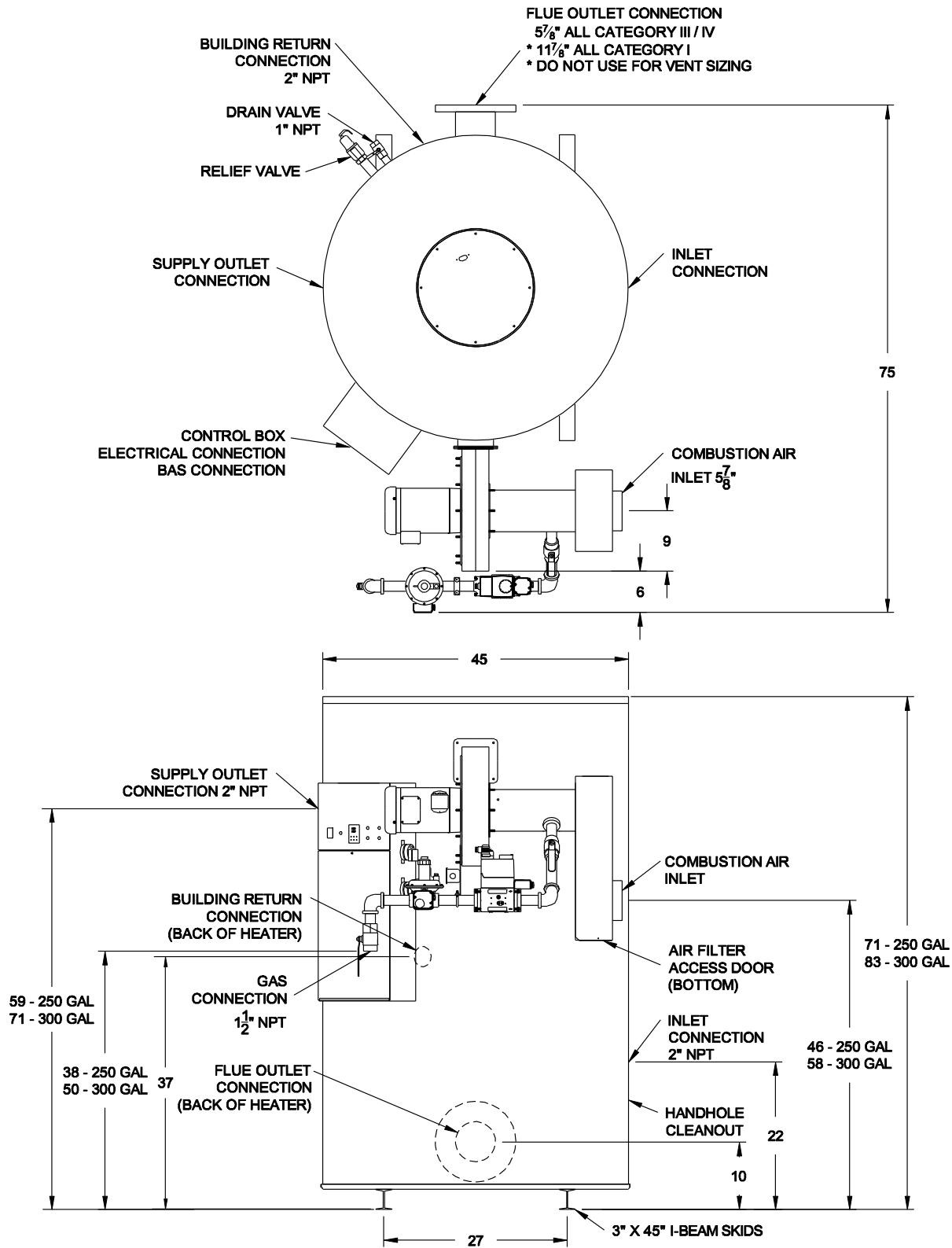

MAXIM 3 WATER HEATER

3 WATER HEATER INSTALLATION

3.1 Checking Equipment Before You Install

- Inspect the unit completely upon receipt from the freight carrier before signing the bill of lading. Inspect the appliance and all accompanying parts for signs of impact or mishandling. Verify the total number of pieces shown on packing slips with those actually received. Contact the freight carrier immediately if any damage or shortage is detected.
- Check the data decal on the appliance. Be sure the electrical, water and gas supply is adequate for the installation.
- Carefully remove all side and top shipping supports and bracing. If possible, do not remove the wooden base/skid assembly until the product has been moved to its final location for installation and operation (see: Handling and Locating the Water Heater)

3.2 Codes

The equipment must be installed in accordance with those installation regulations in force in the local area where the installation is to be made. Authorities having jurisdiction must be consulted before installation is made. In the absence of such requirements, the installation must be in accordance with the instructions in this manual, appliance markings and supplemental instructions and in compliance with the latest edition of the National Fuel Gas Code, ANSI Z223.1/NFPA 54. Where required by the Canadian authority having jurisdiction, the equipment must be installed in accordance with the latest edition of the CSA B149.1 Natural Gas and Propane Installation Code and applicable Provincial Regulations. All appliances conform to the current edition of the ASME Boiler and Pressure Vessel Code, Section IV, Part HLW.

3.3 Electrical Requirements

See appliance rating decal for electrical service requirements. The appliance must be electrically supplied and grounded in accordance with the requirements of the authority having jurisdiction or in the absence of such requirements, with the latest edition of the National Electrical Code ANSI/NFPA No. 70. In Canada, the electrical service must conform to local electrical codes and/or CSA C22.1, Canadian Electrical Code, Part 1.

- All wiring between the unit and field installed devices must be made with type T copper wire.
- Line voltage wire exterior to the appliance must be enclosed in approved conduit or approved metal clad cable.
- To avoid serious damage, **DO NOT** energize the unit until the system and appliance is full of water.

Utiliser du fil de cuivre de la taille appropriée pour le service électrique entrant. Les dommages résultant de l'utilisation de fil d'aluminium seront exclus du champ d'application de la garantie de cet appareil.

3.4 Handling and Locating the Water Heater

WARNING: Use industry standard safe rigging methods, such as strapping around the water heater base/skid assembly and using spreader bars, when attempting to lift or move this product. Failure to follow industry standard safe rigging methods can result in property damage, serious injury or death.

WARNING: This product should NOT be oriented in any direction other than vertical. Failure to comply may result in equipment damage not covered by the warranty.

1. The water heater must be located indoors.
2. Locate the water heater in an area that is not exposed to freezing temperatures.
3. Locate on a level surface. Although not generally required, a housekeeping pad may be necessary when additional elevation is required to properly drain condensate.
4. Locate the water heater near a floor drain. Locate the unit so if the tank or water connections should leak, water damage will not occur to the adjacent area or to lower floors of the building. When such locations are unavoidable, install an adequately drained metal drain pan underneath the water heater. The manufacturer's warranty does not cover water damage.
5. Floor mounting provisions and tie down anchor points are provided. Pilot holes are indicated on the jacket for securing the equipment. Code requirements vary by geographical location, additional strapping or braces may be required. Please refer to your local codes for specific requirements.
6. Protect associated electrical components and electrical connections from water (dripping, spraying, rain, etc.) during appliance operation and service.
7. Locate the water heater where the vent and air intake piping, when installed, will remain within the maximum equivalent lengths allowed. See Venting.
8. Place the appliance on a level, non-combustible floor. Concrete over wood is not considered non-combustible.

MAXIM 3 WATER HEATER

9. Do not install on carpet or other combustible floor coverings. If installation over a combustible floor is required, follow these guidelines:
- Use a base of hollow clay tile or concrete blocks from 8" to 12" thick and extending 24" beyond the sides.
 - Place the blocks in line so that the holes line up horizontally to provide a clear passage through the blocks.
 - Install 1/2" fireproof millboard with a 20-gage sheet metal cover over the block base.
 - Center the unit on the base. Also follow this procedure if electrical conduit runs through the floor, and beneath the appliance. A field-installed base must meet all local fire and safety code requirements.

3.5 Clearances To Combustible Surfaces

The minimum clearance to combustible material is 24" from the front and 8" from the rear, top, left and right sides of the appliance. The appliance must be installed on a non-combustible floor.

La distance minimale de matières combustibles est de 61cm à partir de l'avant et de 20cm à partir des côtés supérieurs droit et gauche, arrière, de l'appareil. L'appareil doit être installé sur une surface incombustible.

3.6 Service Clearances

Additional clearance beyond the minimum required to combustible material should be considered to facilitate easy access for inspection and service of items such as the burner, gas controls and plumbing connections. Also allow sufficient space for installing and servicing building water, gas, vent, combustion air, electrical, pump and other auxiliary/optional equipment and connections.

3.7 Other Code and Regulatory Clearances and Requirements

Additional clearance beyond the minimum required to combustible materials and service recommendations may be required to comply with local, state or national codes and regulations. It is to the responsibility of the installer to comply with these requirements. Examples of codes or regulations that may apply are the National Electric Code, State/Regional/National drain water and flue emissions regulations, the National Fuel Gas Code, Building Construction and Safety Codes, the Americans with Disabilities Act (ADA) and, in states where a water heater above a certain input or storage capacity is considered a boiler, the applicable boiler code requirements, the applicable boiler installation requirements in "Safety Code for Controls and Safety Devices for Automatically Fired Boilers" (CSD-1) and other regulatory requirements.

4 GENERAL PIPING GUIDELINES

WARNING: Hot outlet and cold water piping materials connected to this product must be suitable for temperatures up to 212°F at normal operating water pressures.

4.1 Inlet and Outlet Connections

1. Use only non-ferrous water piping and fittings. When connecting to the tank, there is no requirement to use di-electric nipples and they are not recommended. Also, do not use galvanized or steel pipe or fittings. Over time, rust can form inside of steel, galvanized or di-electric pipe, nipples or fittings.
2. Install shut-off valves and unions on the inlet and outlet water piping for servicing. Use caution when threading pipe nipples into tank connections to prevent cross threading, or over-tightening. Always use a back-up wrench on tank nipples when tightening unions, valves, etc.
3. Insulate hot water and return circulation lines. Insulate cold water supply lines if subject to freezing during shutdown periods. **IMPORTANT:** Do not use the plumbing connected to the appliance as a ground for welding or any other purpose.
4. Pipe the drain valve to a suitable open drain capable of receiving discharge temperatures up to 212°F.

MAXIM 3 WATER HEATER

4.2 Building Return Piping

To maximize water heater efficiency, do not connect the building return or dishwasher recirculation piping (≈ 5 gpm) directly to the cold inlet. Connect directly to the dedicated building return fitting located at the rear of the tank at mid-tank level.

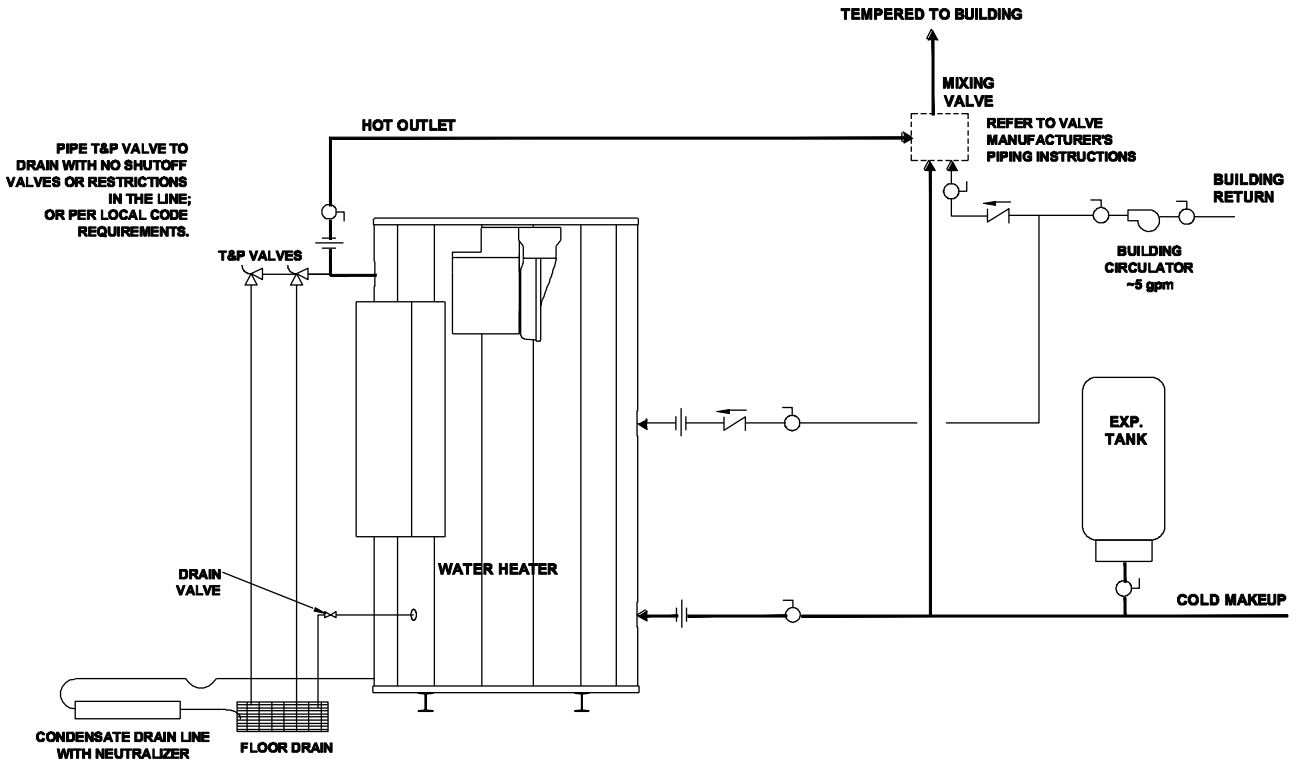

SINGLE WATER PIPING

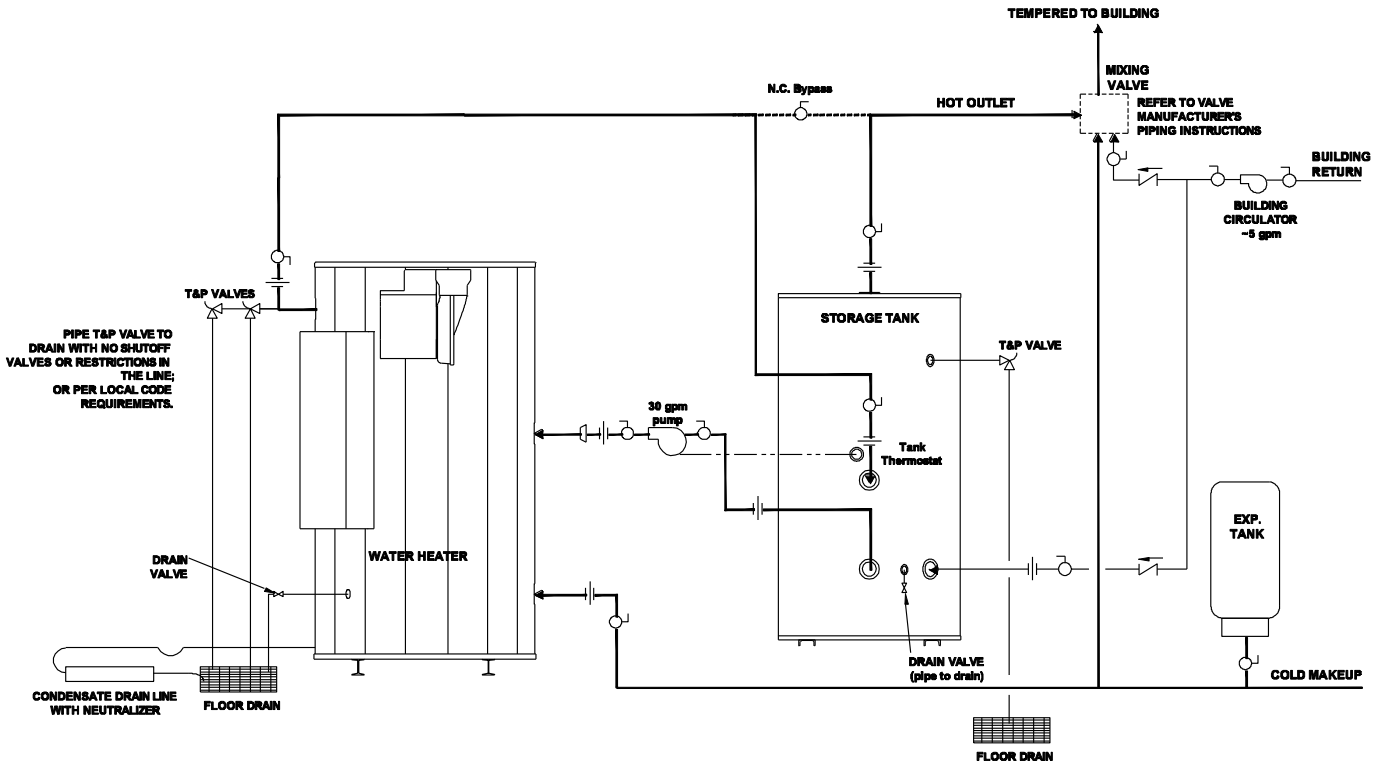

SINGLE STORAGE WATER HEATER WITH SUPPLEMENTAL STORAGE TANK

MAXIM 3 WATER HEATER

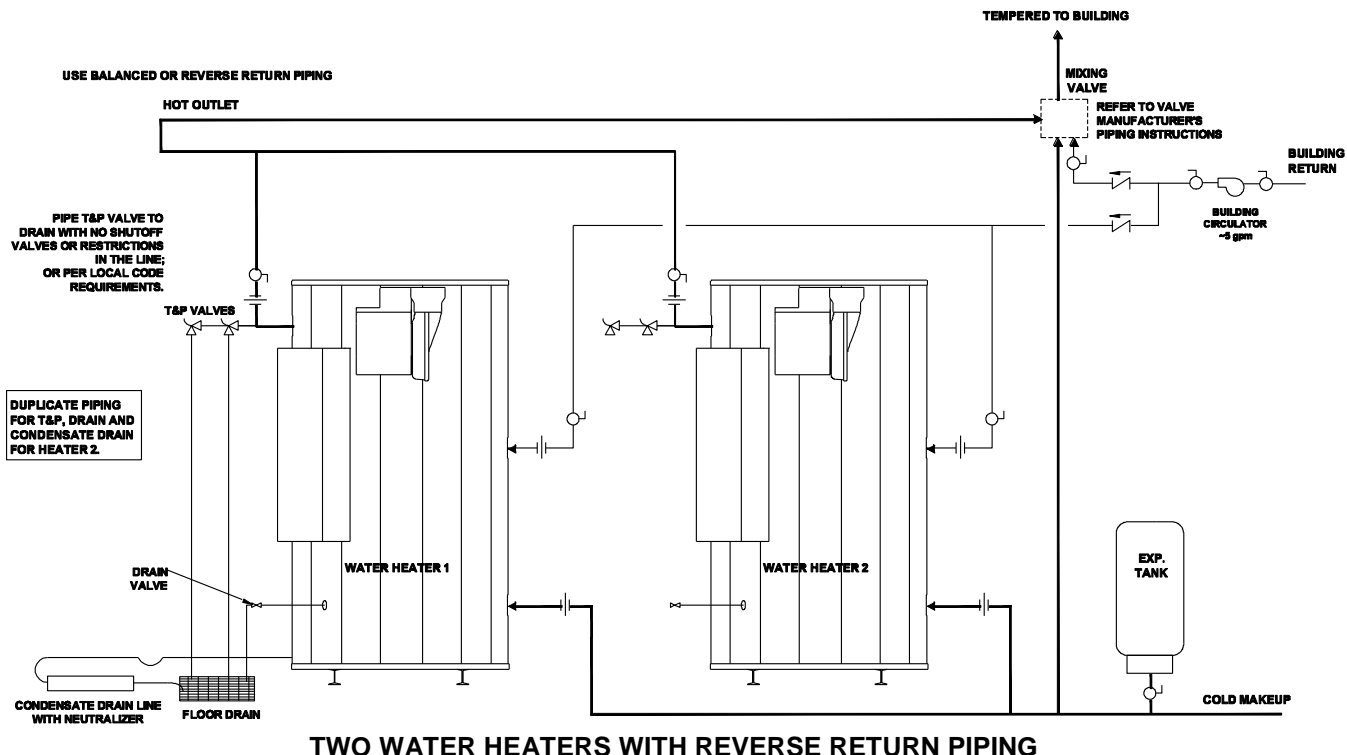

TWO WATER HEATERS WITH REVERSE RETURN PIPING

5 GAS SUPPLY AND PIPING

Verify that the type of gas specified on rating plate is supplied to the unit. This unit is orificed for operation up to 2000 feet altitude. Appliance Btu/h output derates 4% per 1000 feet elevation above sea level. Consult Factory for installations above 2000 feet elevation.

5.1 Gas Train and Controls Certification

NOTE: The gas train and controls assembly provided on this unit have been tested under the applicable Nationally Recognized Standard to comply with safety and performance criteria such as ignition, combustion and safety shutdown operation.

5.2 Gas Control Train

All models include the following gas control train components: manual shutoff valve, two safety shutoff valves, zero governor type regulator, manual test valve and manifold pressure taps. These components may be separate or combined in a common housing.

WARNING: Do not adjust or remove any screws or bolts on gas train control components which are secured with a red or blue sealing compound. In addition to voiding warranties and certification listings, such adjustment or disassembly can cause improper operation which could result in property damage, personal injury or death.

5.3 Inlet Pressure

Measure at the inlet pressure tap located at the main gas cock. The inlet pressure must remain within the minimum and maximum values while the unit is at rest and while the unit is operating at maximum firing rate.

INLET PRESSURE	NAT. GAS	PROPANE
Maximum Static Pressure (Inches-Water Column)	14"	14"
Minimum Flow Pressure (Inches-Water Column)	4.5"	11"

MAXIM 3 WATER HEATER

5.4 Manifold Pressure

Measure at the pressure tap located downstream side of the manual valve closest to the burner. The rated manifold pressure appears on the product data label located near the front of the appliance.

5.5 Gas Piping Size

Do not use the gas pipe connection size to determine the gas supply piping. Designing and sizing a gas supply piping system requires consideration of many factors and must be done by a gas supply piping expert. Always follow NFPA 54 National Fuel Gas Code for gas pipe sizing and gas pipe system design. The following charts provide examples of some of the information used by the gas supply piping expert to determine proper pipe sizes.

Use the values in the following table to add the equivalent straight pipe for each elbow or tee to obtain the total distance from the meter:

CONVERT FITTINGS TO EQUIVALENT STRAIGHT PIPE*								
Diameter Fitting (inches)	3/4"	1"	1 1/4"	1 1/2"	2"	3"	4"	5"
Equivalent Length of Straight Pipe (feet)	2'	2'	3'	4'	5'	10'	14'	20'

Use the following table to determine the possible pipe size based on distance from gas meter for a Single Unit Installation using Schedule 40 Metallic Gas Pipe.*

Equivalent Feet From Meter	SINGLE UNIT INSTALLATION SUGGESTED PIPE SIZE					
	Maximum Capacity for Natural Gas* MBtu/hr Based on 0.5" W.C. Pressure Drop**					
	1-1/4"	1-1/2"	2"	2 1/2"	3"	4"
25	860	1320	2475	3900	7000	-
40	660	990	1900	3000	5300	-
60	-	810	1520	2400	4300	-
80	-	690	1300	2050	3700	-
100	-	620	1150	1850	3250	6700
125	-	-	1020	1650	2950	6000
150	-	-	950	1500	2650	5500
175	-	-	850	1370	2450	5000
200	-	-	800	1280	2280	4600

*See NFPA 54 National Fuel Gas Code for actual pipe size selection and for sizing Propane gas piping

MULTIPLE UNIT INSTALLATIONS SCHEDULE 40 METALLIC GAS PIPE SIZE CHART*														
Maximum Capacity of Pipe in Thousands of Btu's per hour for gas pressures of 14 Inches Water Column (0.5 PSIG) or less and a pressure drop of 0.05 Inch Water Column (Based on NAT GAS, 1025 Btu's per Cubic Foot of Gas and 0.60 Specific Gravity).*														
Nominal Iron Pipe Size, Inches	Length of Pipe in Straight Feet													
	10	20	30	40	50	60	70	80	90	100	125	150	175	200
3/4	369	256	205	174	155	141	128	121	113	106	95	86	79	74
1	697	477	384	328	292	267	246	256	210	200	179	164	49	138
1 1/4	1400	974	789	677	595	543	502	472	441	410	369	333	308	287
1 1/2	2150	1500	1210	1020	923	830	769	707	666	636	564	513	472	441
2	4100	2820	2260	1950	1720	1560	1440	1330	1250	1180	1100	974	871	820
2 1/2	6460	4460	3610	3100	2720	2460	2310	2100	2000	1900	1700	1540	1400	1300
3	11200	7900	6400	5400	4870	4410	4000	3800	3540	3300	3000	2720	2500	2340
4	23500	16100	13100	11100	10000	9000	8300	7690	7380	6870	6150	5640	5130	4720

*See NFPA 54 National Fuel Gas Code for actual pipe size selection and for sizing Propane gas piping

MAXIM 3 WATER HEATER

5.6 Appliance Isolation during Gas Supply Piping Pressure Test

1. The appliance and its provided manual shutoff valve must be disconnected from the gas supply piping system during any pressure testing of that system at test pressures in excess of ½ PSI (3.5 kPa).
2. The appliance must be isolated from the gas supply piping system by closing its individual manual shutoff valve during any pressure testing of the gas supply piping system at test pressures equal to or less than ½ PSI (3.5 kPa).
3. The appliance and its gas connection must be leak-tested before placing it in operation.

5.7 Gas Connection

1. Safe operation of unit requires adequate gas supply with the required static and dynamic (flow) pressures. Actual piping selection depends on many variables that must be carefully considered by the gas piping system designer.
2. Do not select gas pipe sizes based only on the supplied tables. These tables are for use by the gas piping system designer as a reference in checking pipe size selections.
3. Gas pipe size may be larger than heater connection.
4. Installation of a union is suggested for ease of service.
5. Install a manual main gas shutoff valve on the gas supply piping connected to the appliance to isolate the burner and gas train from the main supply gas in compliance with NFPA 54 National Fuel Gas Code and most local Codes.
6. The gas system installer should clearly identify the emergency shut-off device.
7. A sediment trap (drip leg) MUST be provided in the inlet of the gas connection to the unit.
8. The combination gas valves and/or gas regulators incorporate either an internal vent limiter or an externally mounted vent limiting orifice and 1/4" aluminum tube located in a "T" attached to the regulator vent port. Venting to outdoors is not required. Never remove, cut, splice or alter the flexible tubing attached directly to the regulator vent port or to a vent limiting fitting attached externally to the regulator, as this will cause unreliable ignition and can cause improper operation.

Although not required, a connection to the open end of the 1/4" aluminum tube can be made and routed to the outdoors. No other connection point is allowed. Do not remove the aluminum tubing and connect directly to the "T", as damage to the required vent limiter and improper gas control could result.

MAXIM 3 WATER HEATER

6 COMBUSTION AND VENTILATION AIR

Provisions for adequate combustion and ventilation air to the mechanical room must be in accordance with Section "Air for Combustion and Ventilation" in the latest edition of the NFPA 54 National Fuel Gas Code, ANSI Z223.1 and/or CSA B149.1, Natural Gas and Propane Installation Code or applicable provisions of the local building codes. Any method addressed in NFPA 54 National Fuel Gas Code section "Air for Combustion and Ventilation is acceptable and several are outlined below.

6.1 Equipment Located In Confined Spaces

Equipment located in confined spaces requires two openings, one commencing within 12" (30.5 cm) from the top of the enclosure/room and one commencing within 12" from bottom of the enclosure/room to assure adequate combustion air and proper ventilation. The total input of all gas utilization equipment installed in the room must be used to determine the required minimum air volume needed for combustion, ventilation and dilution of flue gasses. Also consider makeup air requirements from other equipment within the mechanical room or other rooms that are pressure connected with the mechanical room. Some examples of other makeup air requirements are from kitchen exhaust hoods, clothes dryers, powered exhaust fans, etc.

- **All Air from Outdoors:**

Each opening requires a minimum free area of 1 square inch per 4000 Btu/hr of the total input rating of all appliances in the enclosure, if directly communicating with the outdoors or communicating to the outdoors through vertical ducts.

Each opening requires a minimum free area of 1 square inch per 2000 Btu/hr of the total input rating of all appliances in the enclosure, if communicating with the outdoors through horizontal ducts.

- **All Air from Inside the Building:**

Follow the requirements of NFPA 54 National Fuel Gas Code, ANSI Z223.1 section "Indoor Combustion Air."

- **Combination of Air from the Indoors and from the Outdoors:**

Follow the requirements of NFPA National Fuel Gas Code, ANSI Z223.1 section "Combination Indoor and Outdoor Combustion Air."

- **From Outdoors Through One Opening:**

Follow the requirements of NFPA National Fuel Gas Code, ANSI Z223.1 section "One Permanent Opening Method."

- **Remote Air Intake System:**

This unit may be installed with a remote air intake system which uses a make-up air duct to draw combustion air directly from outdoors.

NOTE: Use of double-wall vent or insulated material for the combustion air inlet pipe is recommended in cold climates to prevent the condensation of airborne moisture in the incoming combustion air.

WARNING: Adequate clean combustion air must be provided to the appliance. The appliance must never operate under a negative pressure. Particular care must be taken when exhaust fans, compressors, air handling units, etc. may rob air from the appliance. The combustion air supply must be completely free of any chemicals or fumes, which may be corrosive to the appliance. Some common chemical fumes to avoid are fluorocarbons and other halogenated compounds, most commonly present as refrigerants or solvents, such as Freon, trichloroethylene, perchlorethylene, chlorine, etc. These chemicals, when in contact with the equipment or when burned, form acids which quickly attack the tubes, flue collector, stack and other appliance and auxiliary equipment. Failure to provide adequate clean combustion air or operating under negative pressure can cause premature, unwarranted product failure or unsafe operation producing carbon monoxide that could escape into the building. Exposure to carbon monoxide can lead to personal injury or death.

MAXIM 3 WATER HEATER

6.2 Maximum Allowed Remote Combustion Air Inlet Length (Equivalent Length)

A vertical or horizontal remote air inlet system can be connected to this appliance without modification. The maximum length of field supplied single wall pipe, such as galvanized ventilation pipe, is shown in the chart below titled Maximum Air Inlet Duct Equivalent Length. Use metal tape or RTV sealant to seal each pipe joint.

Maximum Air Inlet Duct Equivalent Length / Max Elbows		
Duct Size	6" Duct	8" Duct
Max Equivalent Length	100 feet / 5	250 feet / 10

To determine the maximum straight length of duct allowed, use the Duct Fitting Equivalent Length chart below to find the total equivalent length for all duct fittings in your combustion air system. Then subtract this number of feet from the total equivalent length allowed in Maximum Air Inlet Duct Equivalent Length chart above. The sum of this calculation is the maximum length of straight duct allowed. If a longer length is required, repeat the calculation using a larger duct size. No additional deduction is required for the addition of the duct system terminal.

Duct Fitting Equivalent Length		
Duct Pipe:	6" Duct	8" Duct
90° Elbow	8 feet	10 feet
90° Long Radius Elbow	5 feet	5 feet
45° Elbow	5 feet	5 feet

The following remote air duct information is provided for use in design calculations, if needed.

Remote Air Duct Specifications	
Input MBtu/hr	Required Air (SCFM)
1000	217
1500	350
1800	420
2000	467

6.3 Remote Combustion Air Cap

A UL Listed air intake vent termination cap **MUST** be attached to the remote combustion air vent termination to adequately protect the combustion air inlet from wind and weather. A UL Listed air intake termination cap is available from PVI Industries and may have shipped with the water heater as a purchased option.

6.4 Vertical or Horizontal Remote Air Duct Termination

- Air inlet and exhaust vents must terminate in the same wind pressure area.
- Air inlet must be located no less than 3 feet (0.91m) below the exhaust terminal if they are within 10 feet (3.05 m) of each other, unless the flue outlet terminates with a straight discharge. If the flue outlet terminates with a straight discharge, the air inlet can be located no less than 18 inches (0.46m) below the exhaust terminal.
- If terminating through the roof, the air inlet must terminate at least 12 inches (0.3 m) above roof level and at least 12 inches (0.3 m) above snow levels.
- If terminating through a sidewall, the air inlet must terminate at least 12 inches (0.3 m) above grade and/or at least 12 inches (0.3 m) above possible snow levels.

MAXIM 3 WATER HEATER

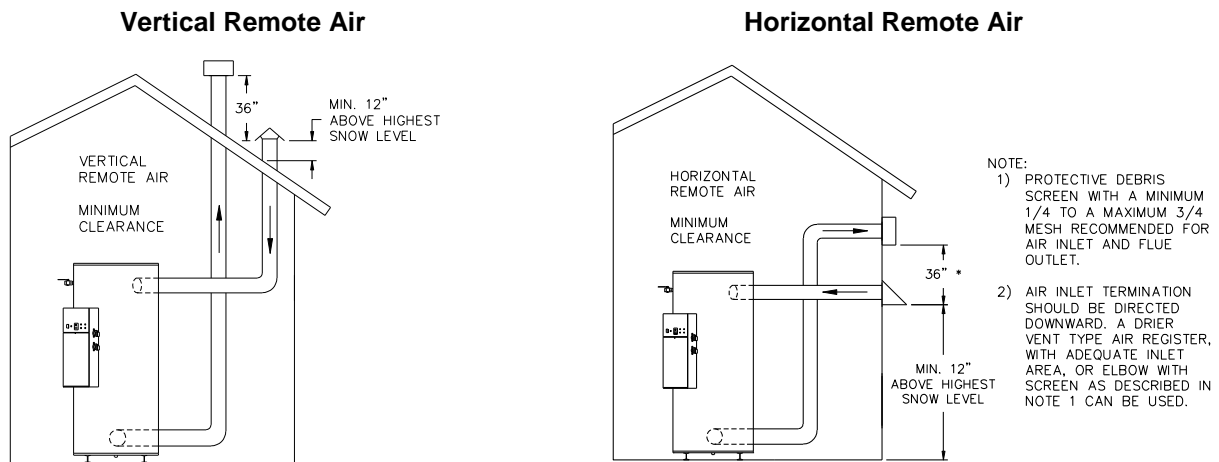

* When flue outlet is terminated with a straight discharge, separation of terminations must be a minimum of 18".

6.5 Combining Remote Air Ducting

Each water heater **MUST** have separate intake piping, unless the air inlet piping, exhaust duct and other system considerations have been fully evaluated and a combined duct system designed by one of the duct design firms identified at www.pvi.com/vent-design.html. Before operation of a combined remote air ducting system, all of the duct design firm's system installation and operation requirements must be in place, their instructions followed and the system must be properly maintained.

Combined air intake piping must incorporate a variable speed blower capable of providing and regulating positive pressure air supplied to all water heaters in the system. **The pressure of the supplied air must not be less than 0.0" W.C. and must not exceed 0.25" W.C.**

The common combustion air supply system must be interlocked, so the water heaters will not begin operation until the common combustion air supply is proved to be within the range of 0.0 to 0.25" W.C. See Section on **Remote Connections** for a discussion of how to connect the proving circuit.

WARNING: Do not combine remote air ducting of multiple appliances into a single remote air duct unless the combined remote air ducting system has been evaluated and designed by a specified duct design firm and the combined remote air duct system is installed, operated and maintained following instructions from that firm. Combining remote air ducting without following these requirements can result in failure of the water heater and venting system and/or exposure to carbon monoxide and can result in property damage, personal injury or death.

7 VENTING

7.1 Venting the Unit using Category I, III or IV Venting Materials

The following instructions can be used to install the Maxim 3 using UL, ULC, ETL or CSA listed, Category I, negative pressure, non-condensing vent materials, like type B venting or it can be installed using smaller diameter UL, ULC, ETL or CSA listed, stainless steel, Category III, positive pressure, non-condensing venting materials. UL, ULC, ETL or CSA listed, stainless steel, Category IV, positive pressure, condensing ready venting materials can also be used to substitute for the Category III venting materials.

Look at the main information decal attached near the front of the unit to determine whether the appliance is for installation utilizing Category I venting only, Category III venting only or if the appliance is for installation utilizing Category I, III or IV venting. Follow the instructions below for the specific Category of venting selected and that appears on the main information decal. Once the Category is selected, follow only the instructions given for that Category.

WARNING: Venting instructions for Category I (negative vent pressure) and Category III/IV (positive vent pressure) must not be mixed. Mixing or following instructions for a different Category can cause inadequate venting or allow carbon monoxide to enter an occupied space, resulting in property damage, personal injury or death.

MAXIM 3 WATER HEATER

7.2 Category I Venting

When properly installed with UL, ULC, ETL or CSA listed Category I venting, the appliance operates with a non-positive vent static pressure and with a vent gas temperature that **avoids excessive condensate production in the vent.**

Category I venting should terminate above the roof surface and must be installed in accordance with the "Venting of Equipment" section of the current edition of the National Fuel Gas Code, ANSI Z223.1 or, in Canada, the "Venting Systems and Air Supply for Appliances" section of the current edition of the CAN/CSA B149 Installation Codes, or applicable provisions of the local building codes.

- Do not use the vent connection size to determine the necessary vent connector, vent or stack size. For proper sizing use the National Fuel Gas Code "Fan-assisted" table.
- Locate unit(s) as close as possible to the vent or stack. The vent connector from the appliance vent connection to the vertical vent or stack that terminates outside and above the building roof must be made with listed Type "B" double wall (or equivalent), must be as direct as possible and must have no blockage or reduction in diameter.
- Support horizontal portions of the venting system to prevent sagging. Horizontal runs must slope upwards not less than 1/4 inch per foot (21 mm/m) from the appliance to the vent terminal. Follow manufacturer's instructions.
- Do not attach the vent connector of any appliance vented by natural draft to any portion of a mechanical draft system operating under positive pressure.
- A barometric damper (draft control) is supplied with all models. Attach the properly sized vent increaser to the water heater vent connection with three sheet metal screws. A properly installed and adjusted barometric damper helps stabilize draft and regulate high updraft. Conventional vented multiple unit installations with combined venting require barometric dampers to regulate draft at each unit. Adjust the barometric damper to 0.04 inches water column updraft, when used. Follow the barometric damper manufacturer's installation instructions.
- **The draft in vent should be within a range of $-.02$ and $-.08$ " W.C.**
- A UL, ULC, ETL or CSA listed vent terminal, suitable for Category I products, **must** be installed to adequately protect the gas vent from wind and weather.
- The vent terminal must extend at least 3 ft (.09 m) above the highest point where it passes through the roof of a building and at least 2 ft (.06 m) higher than any portion of a building within a horizontal distance of 10 ft. (3.0 m).
- The vent cap must terminate at least 3 feet (0.91 m) above any forced air inlet within 10 feet (3.05 m); 4 feet (1.22 m) below, 4 feet (1.22 m) horizontally from or 1 foot (0.3 m) above any door, window or gravity air inlet to the building; 1 foot (0.3 m) above grade, 1 foot (0.3 m) above the highest snow levels and must terminate at least 7 feet (2.13 m) above grade when located adjacent to public walkways or gathering areas.
- The vent terminal must not be installed closer than 3 feet (0.91 m) from an inside corner of an L-shaped structure.

WARNING: Do not combine appliances utilizing Category I or Category II venting into the same vent system with appliances utilizing Category III or Category IV venting. This could cause unsafe operation and the potential for poisonous carbon monoxide to enter occupied areas. Such improper installation can cause property damage, personal injury, exposure to hazardous materials or death.

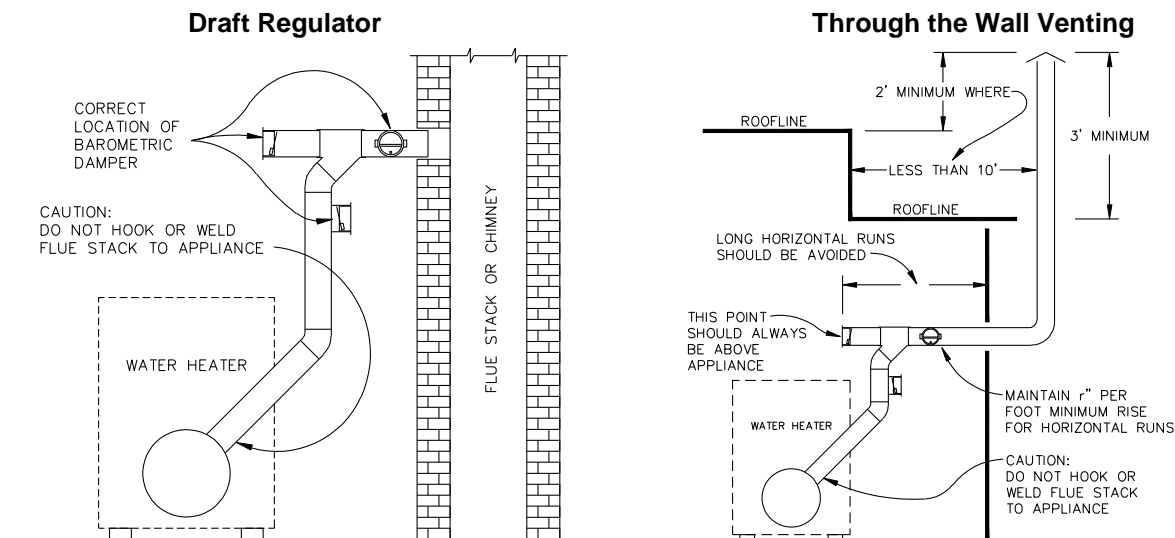

7.3 Category III or IV Venting

MAXIM 3 WATER HEATER

When properly installed with a UL, ULC, ETL or CSA listed, stainless steel, Category III or Category IV vent, the appliance operates with a positive vent static pressure and with a vent gas temperature that **avoids excessive condensate production in the vent**. Although the appliance can be installed to operate and require Category III vent materials, Category IV vent materials can be substituted, but are not required.

The listed Category III or Category IV, stainless steel gas vent connected to this appliance may terminate either above the roof surface or through the side wall. It must comply with the latest edition of the National Fuel Gas Code, ANSI Z223.1 or, in Canada, CAN/CSA B149 Installation Codes, and the applicable provisions of the local building codes.

- **IMPORTANT:** Do not use plastic venting of any type.
- Remove the vent increaser (if equipped) from the water heater vent connection. The Category III or IV venting systems must connect directly to the 5-7/8 inch water heater vent connection and must not use the vent increaser as part of the vent system.
- Obtain the correct adapter for attaching and sealing to the water heater 5-7/8 inch vent connection outlet from the manufacturer of the listed Category III or IV venting system being installed. Attach this adapter to the Maxim 3 vent connection outlet following the instruction provided by the adapter's manufacturer.
- Follow the Category III or Category IV vent manufacturers' instruction for installation, sealing and support of their vent system.
- For proper vent operation and to protect the gas vent from wind and weather, use **ONLY** the listed vent terminal specified by the Category III or Category IV vent system manufacturer.
- **IMPORTANT:** Do not use a barometric damper when applying Category III or Category IV venting.
- This product uses the positive pressure generated by the burner system blower to push combustion products out of the vent. The vent system must be a stainless steel and UL, ULC, ETL, or CSA certified for use with an appliance requiring a Category III or Category IV, pressurized vent system. Seal all joints and support horizontal lengths of vent and follow all installation instructions required by the vent manufacturer.

WARNING: Use only stainless steel venting listed by a nationally recognized testing laboratory for Category III or Category IV, positive pressure, gas appliance venting. Use of plastic pipe of any type or use of venting material other than specified in these instructions can result in failure of the venting system and/or exposure to carbon monoxide, which can result in property damage, personal injury or death.

WARNING: When using Category III or Category IV venting, do not connect this appliance to an existing or traditional gas vent or chimney or combine the vent with any other appliance, except as provided in the section on "Combining Category III or Category IV Vents." Such venting could result in failure of the venting system and/or exposure to carbon monoxide which can result in property damage, personal injury or death.

7.3.1 Maximum Category III or Category IV Vent Length (Equivalent Length)

If a vertical or horizontal Category III or Category IV vent system is used with this appliance, the maximum length of field supplied venting is shown in the chart below.

Maximum Allowable Equivalent Vent Length / Max Elbows		
Vent Size	6" Vent	8" Vent
Max Equivalent Length	100 feet / 15	250 feet / 10

Pipe fittings reduce the maximum allowable vent length. Use the Category III or Category IV vent manufacturer's equivalent length deduction for all elbows, terminations, etc. If the information is not readily available from the vent manufacturer, use the Vent Fitting Equivalent Length chart below to find the total equivalent length for all vent fittings in your combustion air system. Then subtract this number of feet from the total equivalent length allowed in Maximum Category III – Category IV Vent Equivalent Length chart above. The sum of this calculation is the maximum length of straight vent allowed. If a longer length is required, repeat the calculation using a larger vent size. When using this chart, no additional deduction is required for the addition of the vent system terminal.

Vent Pipe Fitting Equivalent Length for all Models		
Vent Pipe:	6" Vent	8" Vent
90° Elbow	8 feet	10 feet
90° Long Radius Elbow	5 feet	5 feet
45° Elbow	5 feet	5 feet

MAXIM 3 WATER HEATER

The following vent information is provided for use in design calculations, if needed.

Venting Specifications		
Input MBtu/h	Required Air (cfm)	Max Vent Press. "W.C.
1000	340	1.3
1500	350	1.7
1800	420	2.0
2000	467	2.0

7.3.2 Vertical or Horizontal Vent Termination

1. The vent terminal must have a minimum clearance of 4 feet (1.22 m) horizontally from, and in no case be located above or below, unless a 4 foot (1.22 m) horizontal distance is maintained from electric meters, gas meters, regulators and relief equipment.
2. The vent must terminate at least 3 feet (0.91 m) above any forced air inlet within 10 feet (3.05 m).
3. The vent shall terminate at least 4 feet (1.22 m) below, 4 feet (1.22 m) horizontally from or 1 foot (0.3 m) above any door, window or building air inlet to the building.
4. The vent system shall terminate at least 1 foot (0.3 m) above grade and at least 1 foot (0.3m) above possible snow accumulation levels and shall terminate at least 7 feet (2.13 m) above grade when located adjacent to public walkways or gathering areas.
5. To avoid a blocked flue condition, keep the vent cap clear of snow, ice, leaves, debris, etc.
6. The vent must not exit over a public walkway, near soffit vents or crawl space vents or other areas where condensate or vapor could create a nuisance or hazard or cause property or could be detrimental to the operation of regulators, relief valves or other equipment.
7. A horizontal vent must extend one foot beyond the wall.
8. A horizontal vent terminal must not be installed closer than 3 feet (0.91m) from an inside corner of an L-shaped structure.
9. A vertical vent must exhaust outside the building at least 3 feet (0.91m) above the point of the exit and at least 2 feet (0.61 m) above the highest point of the roof within a 10-foot (3.05 m) radius of the termination.
10. A vertical termination less than 10 feet (0.91 m) from a parapet wall must be a minimum of 2 feet (0.61 m) higher than the parapet wall.

7.3.3 Combining Category III or Category IV Vents

Combined Maxim 3 Category III or Category IV gas vent systems must incorporate an Exhausto, Tjernlund or U.S. Draft variable speed, modulating, mechanical draft inducer capable of maintaining the appropriate negative draft at the end of the common flue, to assure that all water heaters in the combined vent system operate with a negative draft. **Do not exceed negative 0.25" W.C.** See "Combining Vents with a Draft Inducer" illustration below.

WARNING: Do not connect multiple water heaters vents into a single unpowered or fixed speed powered vent. This could cause unsafe operation and the potential for poisonous carbon monoxide to enter occupied areas. Such improper installation can cause property damage, exposure to hazardous materials, personal injury or death.

WARNING: Do not combine appliances utilizing Category I or Category II venting into the same vent system with appliances utilizing Category III or Category IV venting. This could cause unsafe operation and the potential for poisonous carbon monoxide to enter occupied areas. Such improper installation can cause property damage, personal injury, exposure to hazardous materials or death.

MAXIM 3 WATER HEATER

Conventional Venting

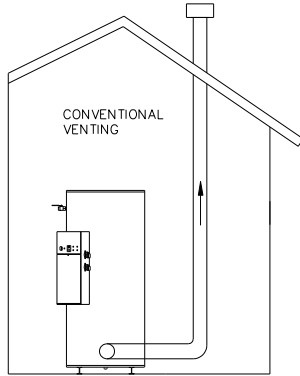

Through the Wall Venting

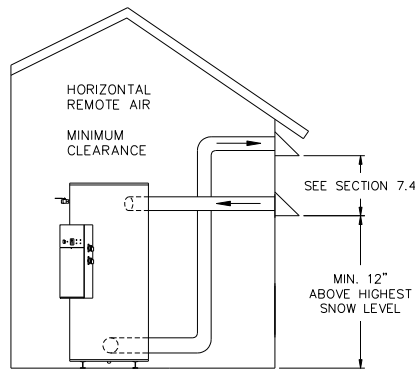

Combining Vents with a Draft Inducer

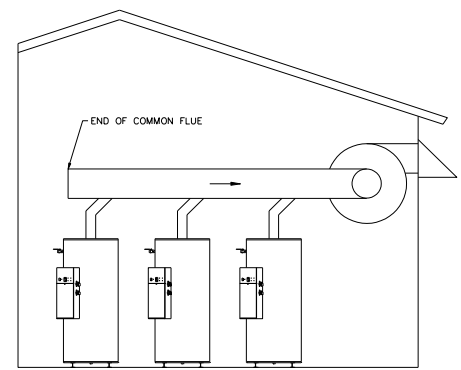

8 OPERATING AND SAFETY CONTROLS

WARNING: Turn off all electrical service to the appliance when accessing the limit or other controls located inside the control cabinet. This cabinet contains High Voltage wiring and terminals. If the electrical service is not turned off and these terminals are touched, a dangerous shock causing personal injury or death could occur. Close and fasten the control cabinet cover before restoring electrical service to the appliance.

Coupez l'alimentation avant intervention sur l'appareil.

8.1 Temperature and Pressure Relief Valve(s)

A Temperature and Pressure Relief Valve(s) sized in accordance with the ASME Boiler and Pressure Vessel Code, Section IV HLW is installed in the tank.

WARNING: Secure the relief valve discharge pipe to a suitable floor drain such that very hot water does not openly splash during a significant relief valve discharge. If the relief valve discharge pipe is not routed and secured to a suitable drain, hot water discharge can result in property damage, scalding and personal injury or death.

- Follow the temperature and pressure relief valve manufacturer's installation instructions and all local, regional and national codes applicable to temperature and pressure relief valve installation and discharge piping.
- The relief valve discharge pipe must not be smaller than the relief valve opening and must be secured to prevent it from lifting out of the drain under discharge pressure and must be routed to allow complete drainage of the valve and line.
- Do not plug the relief valve (s) or install a reducing coupling, valve or other restriction in the relief valve(s) discharge line(s), as this will eliminate the critical water temperature and pressure protection it provides.
- Thermal Expansion - A relief valve that periodically discharges may result from thermal expansion if the water heater is installed in a system closed by components, such as a backflow preventer or check valve in the cold water supply. These systems must be provided with means to control expansion. Contact a water heater or plumbing professional to resolve this situation.

WARNING: Do not plug the relief valve(s), use discharge piping smaller than the relief valve opening or install a reducing coupling, valve or other restriction in the relief valve discharge line. Failure to comply with these relief valve and discharge piping requirements can prevent the relief valve from providing its intended temperature and pressure protection, which can result in property damage, personal injury or death..

MAXIM 3 WATER HEATER

8.2 Cathodic Protection

PVI water heaters do not utilize cathodic protection. However, in hot water systems utilizing cathodic protection, hydrogen gas can be produced when the hot water system has not been used for a long period of time (generally two weeks or more). **Hydrogen gas is extremely flammable.** To prevent the possibility of injury under these conditions, one of the hot water system faucets should be opened for several minutes before using any electrical device connected to the hot water system. If hydrogen is present, there will be an unusual sound such as air escaping through the pipe as the hot water begins to flow. Do not smoke, have open flames or turn electrical switches on or off near the faucet at the time it is open.

8.3 Electronic Low Water Cut-Off (Optional)

When the water level is above the electrode position in the tank, the reset pushbutton will energize the control (LED will be lit). The control remains energized until the water level recedes below the electrode position (LED will not be lit). Unless otherwise specified, there is a three-second time delay on decreasing level. Water level must be below tank probe location for full three seconds before control de-energizes.

8.4 Operating Temperature Control

An adjustable digital operating control is located in the front control panel. The control is factory pre-set at approximately 120°F. To adjust the setpoint to deliver the desired water temperature, press and release the Set 1 key on the face of the control. When setpoint adjustment is enabled, use the arrow keys to adjust the set point to the desired system temperature. See TempTrac Electronic Controller Panel in this manual for more information.

Le thermostat est réglé à environ 49 degrés Celsius. Températures de l'eau supérieures à 52 degrés Celsius peut causer instantanément de graves brûlures ou la mort de brûlures. Suivez les instructions dans le manuel d'installation et de maintenance pour modifier la température de l'eau.

8.5 High Water Temperature Limit Control

The appliance is equipped with adjustable limit and high limit controls to control the maximum discharge water temperature. These controls are located inside the control cabinet and are accessed by removing the bottom cover. The high limit control is optionally available as the manual reset type and may be reset by pressing the limit reset button accessible through a hole in the top left of the control panel cover. Pressing the reset on the high limit control will not cause the control to reset until the water temperature has dropped below the set point of the manual reset high limit control. The adjustable limit is of the auto reset type and can be dial adjusted to operate just above the set point of the main operating temperature control.

9 TEMPTRAC® ELECTRONIC CONTROLLER PANEL

9.1 Principle of Operation

The water heater operates to satisfy the setpoint of the TempTrac® digital control whose sensor is located near the top of the water heater tank. Demand (flow) will typically create a drop in temperature, thus activating the water heater to add heat to the stored water. This setpoint is the desired water temperature to maintain.



MAXIM 3 WATER HEATER

9.2 Lower LED Readout

The default display of the lower readout (Probe 1) is the stored water temperature sensed near the top of the water heater tank. This is used to regulate the temperature of the water heater.

9.3 Upper LED Readout

The default display of this readout will display “nu”. This readout can display a temperature reading from a 2nd probe. The 2nd probe can be installed in a thermal well (this optional probe and thermal well, with heat conductive paste, is custom and must be ordered from your PVI representative or directly from PVI) to remotely monitor water temperatures, such as blended water temperature, downstream of a thermal mixing valve or a remote storage tank. Both Probe 1 and Probe 2 temperatures are available for monitoring through the optional MODBUS RTU interface.

9.4 Control Buttons

SET	Displays and modifies the temperature set points. In programming mode, it selects a parameter or confirms an operation.
UP	Displays and modifies the energy saving (Night Time setback) settings. In programming mode, it browses the parameter codes or increases a displayed value.
DOWN	Displays the working hours of the load relays. In programming mode, it browses the parameter codes or decreases a displayed value.
CLOCK	Changes lower display from the stored water temperature to current time and day.
EXT	Changes upper display from Probe 2 temperature to Probe 1 or 3 temperatures (when installed). Also displays the temperature difference of the stored water temperature minus Probe 2 temperature and firing rate of the burner from 0 to 100%. In programming mode it sets the 4-20mA output (password is required).
ON/OFF	Switches the control ON or OFF. The BAS can still monitor the probe temperatures. The heater will not heat when in the off-state.

(See TempTrac User Manual PV500-41 for full description)

9.5 To View the Setpoint

- Push and release the **SET** key to see the set point value.
- To return to normal display, press **SET + UP** or wait 30 seconds without pressing any key.

9.6 To Change the Setpoint

- Push the **SET** key. The upper display will show the “St1” parameter name, while the lower display will show its value.
- Use the **UP** or **DOWN** key to cycle through the parameter names.
- Push the **SET** key to modify a parameter value. The value starts flashing in the lower display.
- To change it push the **UP** or **DOWN** keys. Push the **SET** key again to confirm the value and pass to the setting of next set point.
- Repeat the operations described at points 3, 4, 5.
- **To Exit:** press **SET + UP** or wait 30 seconds without pressing any key.

NOTE: Each point has a time out of 30 seconds. If any key is pushed within 30 seconds the controller exits the set points programming procedure.

NOTE: The set value is stored even when the procedure is exited by waiting the time-out to expire.

MAXIM 3 WATER HEATER

9.7 To Change Other Parameters

- Push the **SET and DOWN** arrow simultaneously for 3 seconds.
- Select the required parameter. The name of the parameter is on the upper display; its value is on the lower display.
- Press the **SET** key: the value of the parameter will start blinking.
- Use **UP** or **DOWN** to change the value.
- Press **SET** to store the new value and move to the following parameter.
- **To Exit:** Press **SET + UP** or wait 30 seconds without pressing a key.















9.8 LED Display Alarm Messages

Alarm messages are displayed in the upper LED readout and alternate with the default display. An alarm LED ICON is also illuminated. (See TempTrac User Manual PV500-41 for full description.)

ALARM MESSAGE	CAUSE	RESULTS OF ALARM CONDITION	RECOMMENDED ACTION
"P1"	TP1 probe failure	Tank temperature sensor is not connected or is reading incorrectly. Call for heat and burner modulation output signal will revert to low fire.	Check wiring and sensor Terminals 14 & 17
"P2"	TP2 probe failure	Temperature sensor is not connected or is reading incorrectly.	Check wiring and sensor Terminals 15 & 17
"P3"	TP3 probe failure	Temperature sensor is not connected or is reading incorrectly or flue gas temperature protection is disabled (if used).	Check wiring and sensor Terminals 16 & 17
"HA"	High temperature limit setpoint exceeded	Audible alarm sounds, operation continues.	Manual reset required
"LA"	Low temperature alarm	Audible alarm sounds, operation continues.	
AL2	Digital input 3 is activated for one or more of the following: Flame failure or any control component failure, if equipped with alarm on any failure option	Unit de-energized after time delay. Audible alarm sounds. On some products, the alarm contacts (Output 2) may close for remote indication of alarm. Internal alarm register will communicate an alarm condition through the Modbus RTU communication link (if equipped).	Manually reset required
AL3	Digital input 2 is activated	Unit de-energized after timer delay.	Manually reset required
Mn1	Maintenance alarm for output 1	Audible alarm sounds, operation continues.	Check wiring and sensor
Mn2	Maintenance alarm for output 2	Audible alarm sounds, operation continues.	Check wiring and sensor
Mn3	Maintenance alarm for output 3	Audible alarm sounds, operation continues.	Check wiring and sensor
"rtc"	The real time clock has lost its setting	Energy saving function disabled.	Reprogram clock

MAXIM 3 WATER HEATER

9.9 LED Icon Legend

LED	MODE	Function
°F	ON	Temperatures are displayed in degrees Fahrenheit
°C	ON	Temperatures are displayed in degrees Celsius
	Flashing	Call for heat time delay or remote enable/disable is in standby (disabled)
	ON	Call for heat is on
	Flashing	Second stage time delay (<i>On 2-stage units only</i>)
	ON	Second stage on or the AL2 alarm output is enabled.
	Flashing	Output 3 time delay
	ON	Output 3 relay on
	ON	Modulation output signal is in manual control mode or forced to the i1S setting by digital input 1
	ON	Modulation output signal is automatically controlled by temperature probe 1
	Flashing	Modulation output time delay is activated.
Ext	ON	Probe 3 is displayed
	FLASHING	Digital input 2 (alarm) is activated
	FLASHING	Digital input 3 (alarm) is activated
	ON	Lower display is displaying the time
	FLASHING	Alarm signal
	FLASHING	Programmed working hours limit is exceeded
	ON	Working hours are displayed in Lower LED readout
ES	ON	The energy saving function is running

MAXIM 3 WATER HEATER

10 REMOTE CONNECTIONS – TERMINAL STRIP

10.1 Making BMS/BAS Remote Connections for Analog and Binary (on/off) Signals

A terminal strip for the remote connection is located behind the hinged control panel at the top of the cabinet and is accessed by removing the bottom cover and then removing the screws at the top of the hinged cover.

IMPORTANT: Do not use single strand bell wire for remote field connections to terminals R1-R2 and C1-C2. Use only multi-strand copper wire. See table below for wire length and gauge:

Wire Gauge	18 GA	16GA	14 GA	12 GA
Maximum Length	30 FT	50 FT	75 FT	100 FT

WARNING: Turn off all electrical service to the appliance when accessing the remote connections located inside the control cabinet. High voltage is present within the control cabinet. If the electrical service is not turned off and these terminals are touched, a dangerous shock causing personal injury or death could occur. Close and fasten the control cabinet cover before restoring electrical service to the appliance.

Coupez l'alimentation avant intervention sur l'appareil.

10.2 The Following Describes The Functions Of Each Of These Terminals And The Factory-Installed Options Required To Activate The Terminals:

NOTE: Terminals **P1-P2** are functional only when the water heater is equipped with the factory installed options required to activate the terminals. Terminals **R1-R2**, **A1-A2**, **C1-C2** and **T1-T2** are standard pre-wired functions on all models.

R1-R2: Used to activate /de-activate water heater from remote master control.

Terminals are wired to a relay in a remote Energy Management System. When relay closes, circuit from R1 to R2 is completed and appliance controls are enabled. Appliance ships from factory with jumper between terminals. Remove jumper when connecting to a remote controller. It is recommended to have a minimum 10A contact located at or close to the heater to provide a proper circuit; 14AWG wire minimum.

A1-A2: Used to activate a remote alarm, signaling shutdown of combustion control.

Provides a maximum 10 amp relay contact closure when the flame safeguard terminates combustion due to a tripped safety interlock (i.e.: air proving switch, high limit switch, low water flow switch or flame sensor, etc.).

P1-P2: Activates remote equipment and requires confirmation signal back to the appliance.

Provides a maximum 10-amp relay contact closure to activate a remote device (i.e.: mechanical room air louvers, draft inducer or power vent, etc.). The remote device must send return signal via proving switch to confirming proper operation to terminals C1-C2, prior to the appliance being able to energize. **Options Required - Consult Factory.**

C1-C2: Used for proving operation of remote device.

Terminals are wired to a proving switch on a remote device such as a power venter. When relay closes, circuit from C1 to C2 is completed and appliance controls are enabled. This appliance ships from the factory with jumper between terminals.

T1-T2: Used for external modulation control.

To connect external modulation control, disconnect and cap the purple wire connected to terminal T2 and connect the external modulating signal to terminals T1 (negative) and T2 (positive).

MAXIM 3 WATER HEATER

11 SEQUENCE OF OPERATION

1. Incoming power

- a. Full time power from 120 VAC control transformer or 120 VAC house power to the Main Control Switch.
- b. Full time power to the Variable Frequency Drive; this can be other voltages. House power as specified by heater specifications.

2. Power On - When the main control switch is turned on:

- a. 120V is applied to the step-down transformer (24V).
- b. 120V is applied to the L.W.C.O. terminal L1 (if used).
- c. 120V is applied to the Fenwal Flame Safeguard Control.
- d. 24V is applied to the TempTrac operating temperature control terminal L1.

3. Call For Heat - If the TempTrac operating control senses a call-for-heat condition:

- a. The high gas pressure and low gas pressure switch (both optional) are energized and their safe condition is proved.
- b. The thermostat contact on the Fenwal Flame Safeguard Control is energized.
- c. The flame control will then verify the Airflow-Proving Switch is in the open position, which must exist before the blower is powered.
- d. If the airflow proving switch is not in the closed position, the flame control's fan terminals F1-F2 will power the Variable Frequency Drive (VFD) blower system at low speed for pre-purge. Energizing the blower should close the airflow proving switch.
- e. If the airflow-proving switch does not close following the blower being energized, the flame control will lockout.

4. Proof of Air Pressure Switch - The control will look for a signal from the airflow-proving switch, indicating that the blower is operating:

- a. When the airflow generated by the blower is sufficient to cause the differential air switch to close, the 15 second pre-purge delay will start.
- b. During this period any flue products or combustible gases which may have settled in the water heater are evacuated.

5. Heat-Up - Following the pre-purge delay, the hot surface igniter will be energized:

- a. The flame control will monitor the current applied to the hot surface igniter.
- b. If the flame control determines the proving current meets the threshold, a dwell time delay starts to assure the hot surface igniter has sufficient time to reach ignition temperature.

6. Ignition - When dwell time is completed a 4-second Trial for Ignition (TFI) period is initiated:

- a. The Delay-On (Low Fire Hold) Relay and the Gas Safety Valves are energized.
- b. During TFI the flame safeguard control will monitor the flame using flame rectification through the hot surface igniter.
- c. If the flame control senses the presence of flame before the end of the TFI period, the igniter will be de-energized and the flame control will continue to monitor the flame, through the igniter, until the operating thermostat ends the call for heat condition.

7. Loss of Flame Signal

- a. If the igniter fails to sense flame at any time, the igniter and gas valve will be de-energized and the flame control will reset and begin the call-for-heat sequence again. This will occur 3 times (one time if CSD-1) before the flame control will lockout.
- b. When the call for heat condition ends or flame failure occurs following the third TFI period (one time if CSD-1), a 30-second post-purge period will begin. This period of blower operation will exhaust any remaining combustion products from the system.

MAXIM 3 WATER HEATER

- 8. Delay-On Relay** - Once the Delay-On (Low Fire Hold) Relay has timed out, it energizes the Modulation Release Relay (SPDT) to enable the analog signal from the TempTrac to the VFD to regulate the speed of the blower.
- The TempTrac will continue to monitor the stored water temperature in the tank.
 - When the setpoint temperature is reached the call-for-heat signal to the flame safeguard control is discontinued. The gas valve is de-energized and post-purge period begins.
 - After the post-purge period, the flame safeguard control de-energizes the VFD blower system and the gas valve, thereby suspending burner operation.
 - As heat is transferred to the building, the water heater loop temperature will fall below the set point. The TempTrac will sense this condition and begin the call-for-heat sequence again.
- 9. Flame Safeguard LED Diagnostic Indicator** - If the Fenwal Flame Safeguard Control at any time during the operating sequence senses an improper operating state and locks out, the diagnostic red LED located on the control board will flash to indicate one of the following conditions exist:

LED INDICATION	FAULT MODE
On	Normal Operation
OFF	Internal Control Failure – check power
1 Flash	Airflow Fault
2 Flashes	Erroneous Flame Signal
3 Flashes	Ignition Lockout
4 Flashes	Hot Surface Igniter Fault
5 Flashes	Low Voltage (24 VAC)
6 Flashes	Valve Relay Problem

MAXIM 3 WATER HEATER

12 INITIAL STARTUP

12.1 Initial Startup Requirements

Installation should be complete prior to performing initial startup; and the startup must be complete prior to placing the water heater into service. Starting the water heater without proper piping, combustion air, venting or electrical systems can be dangerous and may void the product warranty. The following startup instructions should be followed precisely in order to achieve safe and efficient operation to assure trouble-free service life.

WARNING: Proper startup must be made by a qualified installer or service agency, who must read and follow the supplied instructions and appliance markings. Failure to complete proper startup before use, tampering with controls or not following all instructions and markings may damage this equipment, void the warranty and may result in property damage, personal injury or death.

A Start-up Form is included with each product and must be completed by the qualified installer or service agency conducting the startup and must be returned to the manufacture to register the warranty. Copies are available at www.pvi.com.

WARNING: Turn off all power to the water heater when servicing or accessing the blower drive. The blower drive still has power when appliance switch is off. Failure to turn off all power to the water heater can cause personal injury, property damage or death.

12.2 Tools and Instrumentation Required

- Stack Temperature Gauge
- Stack Draft Gauge
- Electronic Combustion Analyzer
- Manometer for checking gas pressure (2 minimum)
- AC/DC Multi-meter (with 20,000 OHM/Volt rating)
- Amp Meter
- Normal Hand Tools

12.3 Resources

- Product Installation & Maintenance Manuals
- Start-up Report with instructions
- Local, State, & Federal Codes
- Toll Free 24-Hour Technical Support: 1-800-433-5654

12.4 On Site Considerations

- Electrical Supply in accordance with Nameplate Rating
- Uncontaminated Combustion Air
- Adequate Fuel Supply
- Treated Water Supply
- Consistent Draft

12.5 Startup Procedure

1. Carefully study the burner start-up information included in this manual.
2. Fill system tank with water.
 - a. Close the drain valve.
 - b. Open a nearby hot water faucet to permit the air in the system to escape.
 - c. Fully open the cold water inlet valve to fill the tank.
 - d. Close the hot water faucet opened in step b when water starts to flow.
 - e. If venting through the safety valve when filling the appliance, insure gags or fixtures are removed from the safety valve prior to start-up. Open the safety valve to allow air in the tank to escape.
3. Be sure all connections into the tank are tight, as leaks at tank fittings will damage the insulation.

MAXIM 3 WATER HEATER

4. **CAUTION:** Conduct the following gas train leakage test before start-up, at annual intervals and prior to investigating the cause of any reported occurrences of delayed ignition.
 - a. Using an appropriate bubble detection solution, thoroughly coat all gas train pipe connections. If any bubbles are detected, the leaking connection must be tightened, recoated, and rechecked to assure stoppage of the leak.
 - b. Attach a manometer to measure the gas pressure at the manual gas shutoff valve located just upstream of the gas train. Adjust gas train inlet pressure to the specified value (e.g. 14" W.C.), and tightly close the gas train manual shutoff valve closest to the burner.
 - c. Reattach the manometer to the gas train manual shutoff valve at the burner and record the measured gas pressure in inches of water column (W.C.). Measure gas pressure again after 15 minutes. If gas pressure has increased 0.5" W.C. or more, the gas leak must be isolated to one or more of the operating gas valves. (For example, a solenoid actuated gas shutoff valve.) After any leaking valve is replaced, the reassembled gas train must be leak tested again before start-up is attempted.
5. Remove enclosure panel cover on the appliance to expose control circuit. A wiring diagram, included with the appliance, will show the controls used in our circuitry.
6. Visually check that all components are intact and no damage has occurred during transit.
7. Check all connections within the control cabinet. A loose connection could cause intermittent shutdowns.
8. The burner will use a hot surface igniter (HSI) as the ignition source. They may utilize a single gas train of a pressure regulator and valves, or a valve regulator combination or utilize multiple gas trains.
9. Connect a test meter to the ignition control to read the flame current in microamps.
NOTE: Some flame controls read the flame signal in micro amps and some in volts DC.
10. **CAUTION:** Be sure the tank is filled with water. Dry firing can cause unwarranted damage to the appliance.
11. Check the inlet gas pressure before start-up, using a manometer or a 0 to 28" W.C. pressure gauge for inlet gas pressure. (This is the pressure measured before all components in the gas train.) This manometer must stay connected throughout the testing, as the inlet pressure must be monitored during the firing of the burner. Record static pressure; it must not exceed 14" W.C. Pressures above this could cause damage to the diaphragm in the gas valve or pressure regulator. The inlet gas pressure must not fall below 3.5" W.C.
12. Connect a second manometer to the manifold test port at the shutoff valve closest to the burner.
13. **Turn-off main gas shutoff valve.**
14. **Disable or jumper out any BMS/BAS control interface to allow independent setup and adjustment of each water heater. If utilizing Modbus RTU, you can unplug the Modbus cable to disable. If utilizing remote contact, you can jumper T1-T2 terminals**
15. Turn unit on using the rocker switch on the front of the control enclosure assembly. When the burner fails to light, the flame control will lockout.
The burner combustion must be optimized during startup.
16. **Turn-on main gas shutoff valve and reset low gas pressure switch (if equipped).**
17. If the TempTrac operating control switch is closed (indicated by the  icon), the burner blower should come on and pre-purge begins.
18. If nothing happens, check for a safety device lockout. Some safety devices such as the Low Water Cut-off, Gas Pressure Switches (if equipped) and the High Temperature limit will require manual reset after lockout and therefore can be easily identified.
19. When the blower motor starts, the Flame Ignition Control will not be energized until positive air flow is established and the Remote Proving Interlock, when used, has closed. If the Flame Ignition Control does not energize, see the troubleshooting guide for help.
20. The Air Proving Switch can be easily identified by checking for 24V on both sides of the switch.
21. If the amber colored call-for-heat indicating light is not illuminated, it is likely that the Remote proving interlock is open. Check remote device.
22. After the pre-purge, the flame control energizes the HSI for the heat up period, approximately 30 seconds. At the end of that period the gas valve is opened for approximately 4 seconds. After the burner has lit and the primary safety control senses a flame, the burner will remain on until the call for heat is satisfied or operation is interrupted by a safety device.
23. If the burner fails to light, the flame control will recycle two more times before lockout. When lockout occurs, press the reset button on the side of the control enclosure to recycle the burner. When the burner fails to ignite, the most common cause at startup is air in the gas supply. This can usually be corrected with multiple cycles or bleeding the line manually. If the burner lights but blows out, insure that the burner firing rate is locked in low fire and check for improper combustion or weak flame signal as a possible cause.

MAXIM 3 WATER HEATER

24. Once the main burner flame is established the firing rate will be controlled by the TempTrac control. Refer to TempTrac manual PV500-41.

Burner Combustion Adjustment

Burner combustion should only be adjusted using a combustion analyzer. Do not attempt to adjust burner by sound or sight. With the burner firing, insert the combustion analyzer probe in the flue vent approximately two feet from the appliance. **See Gas Train Illustration below for details.**

With the burner firing, adjust the regulator screw clockwise to increase gas flow or counter clockwise to decrease flow. The desired CO₂ in the combustion products should be between 8.0 and 9.0% for natural gas, 9.5% to 10.5% for LP gas. Do not attempt to adjust combustion based on manifold pressure alone. Manifold pressure should only be used as a reference point.

CAUTION: If at any point carbon monoxide is in excess of 300ppm, contact PVI Industries customer service for assistance.

25. Enable or reconnect any BMS/BAS control interface removed prior to the setup and adjustment of each water heater.

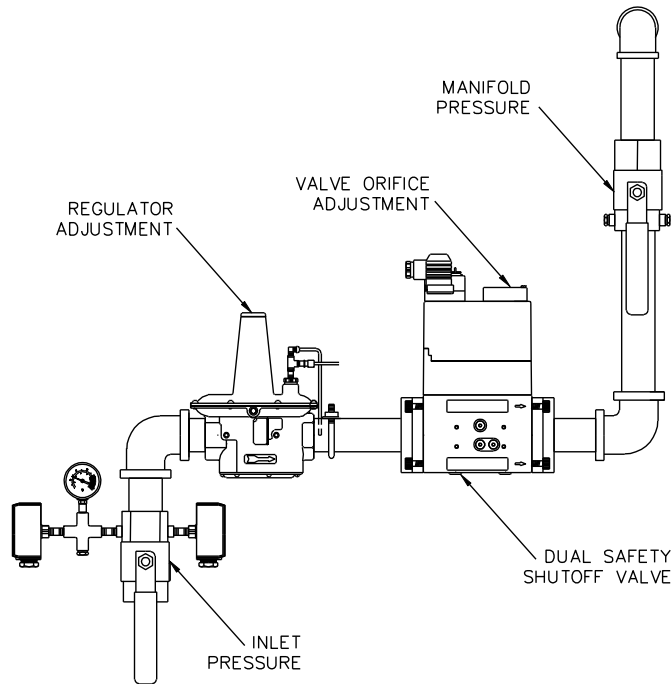

Gas Train Illustration
(Optional components may not be shown)

MAXIM 3 WATER HEATER

13 TROUBLESHOOTING GUIDE

Problem	Probable Cause	Corrective Action	
Starting or Pre-purge Failure	Power Supply	Check fuse and/or circuit breaker. Check voltage at 120/24V step-down transformer.	
	On-Off Switch	Check if On-Off switch is lighted	
	Temperature Control (TempTrac)	Check that the operating temperature control is set higher than the temperature of the water heater. See Table 10.8 for indications of control or sensor faults.	
	Flame Safeguard Control	Check for bad ground or bad control. Replace if necessary. Reset control.	
	Remote enable/disable open	Enable water heater or place jumper between terminals R1-R2.	
	Combustion Air blower		Check if fan connection terminals on flame control are closed.
			Check for 24V at field access terminal C2. Remote interlock may be open.
			Blower motor may have failed.
			Fan VFD may be defective. Verify proper voltage.
	Air-proving Switch		Check switch contacts are closed.
			Check for 24V at the N.O. side of air switch.
			Check for 24V at the common side of air switch.
			Check if switch tubing is connected on both ends.
		Check for proper blower pressure setting – adjust if required. Air switch may be defective.	
Blocked Filter Switch	Check for 24V at the N.C. side of the blocked filter switch. Replace filter or switch as required.		
Flame Control Pressure Switch	Check for 24V at the pressure switch terminal.		
Loose Wire Connections	Check connections to all components.		
Flame Failure	Power Supply	Check fuse and/or circuit breaker. Check voltage at 120/24V step-down transformer.	
	Flame Safeguard Control	Check for bad ground or bad control. Replace if necessary. Reset control.	
	Hot Surface Igniter	Check resistance at room temperature and then the amperage draw during heat-up. Replace if the measured amperage is not within 3.5 to 5.0 Amps or if measured resistance is not within 40-100 ohms (at room temperature). Also, check for overheating condition due to damaged refractory around igniter.	
	Air-proving Switch	Check if switch is bouncing. Adjust or replace. Check VFD for proper speed settings.	
	Gas Pressure	Check for proper inlet static and dynamic gas pressure, 3.5" W.C. minimum.	
	Combustion	Inadequate flame signal may result from improper combustion. Adjust to proper CO2 levels at low fire. Inability to achieve proper combustion throughout the modulation range may be caused by a defective gas valve, regulator or blockage in the in the burner or combustion air supply.	
	Grounding	Check for proper ground from flame control to burner housing.	
	Safety Limits	Check all safety limits for fault condition and correct as required.	

MAXIM 3 WATER HEATER

13.1 Troubleshooting Guide to be used with Wiring Diagram:

Verify power from ground lug to:

L1 -120VAC Check circuit breaker and/or disconnect

L1 FUSED – 120VAC Check switch, check fuse

L2 – 0VAC Check electrical connections from building

L3 – 24VAC Check transformer and fuse

L4 – 0VAC Check ground wiring in control panel

Have setpoint high enough, it should be heating:

Take readings from Ground lug to the following with meter on VAC. This is in order of signal and should be followed in order for the cause to be valid. FAT – Field Access Terminal strip at top behind TempTrac. TS – Terminal Strip inside lower control cabinet going in lower left side, arranged vertically.

POINT TO TEST	Good reading	Bad Reading	CAUSE: What to look at, if not a good reading
R1 (FAT)	24VAC	0VAC	No signal from TempTrac, verify that it is turned on, and operational.
R2 (FAT)	24VAC	0VAC	Remote ON/OFF contact is open.
ELWCO (TS)	0VAC	24VAC	Low Water Cutoff is tripped.
HIGH TEMP LIMIT (TS)	24VAC	0VAC	Manual or auto temp limit is tripped.
HIGH PRESS GAS (TS)	0VAC	24VAC	High gas pressure is tripped.
LOW PRESS GAS (TS)	0VAC	24VAC	Low gas pressure is tripped.
C1 (FAT)	24VAC	0VAC	If R1 is good, then one of the above items.
C2 (FAT)	24VAC	0VAC	Remote proving contact is open.
VALVE (TS) has brown wires going to it	24VAC After Purge	0VAC	Fenwal has not finished purging. Verify the VFD is operating. Verify air proving and filter switch. Fenwal is locked out. Fenwal failure.
		7-21VAC	Large voltage drop in one of the above devices. Transformer cannot supply load. Valve solenoid is drawing too much current.

REPLACEMENT PARTS

MAXIM 3 WATER HEATER

14.1 Control Panel

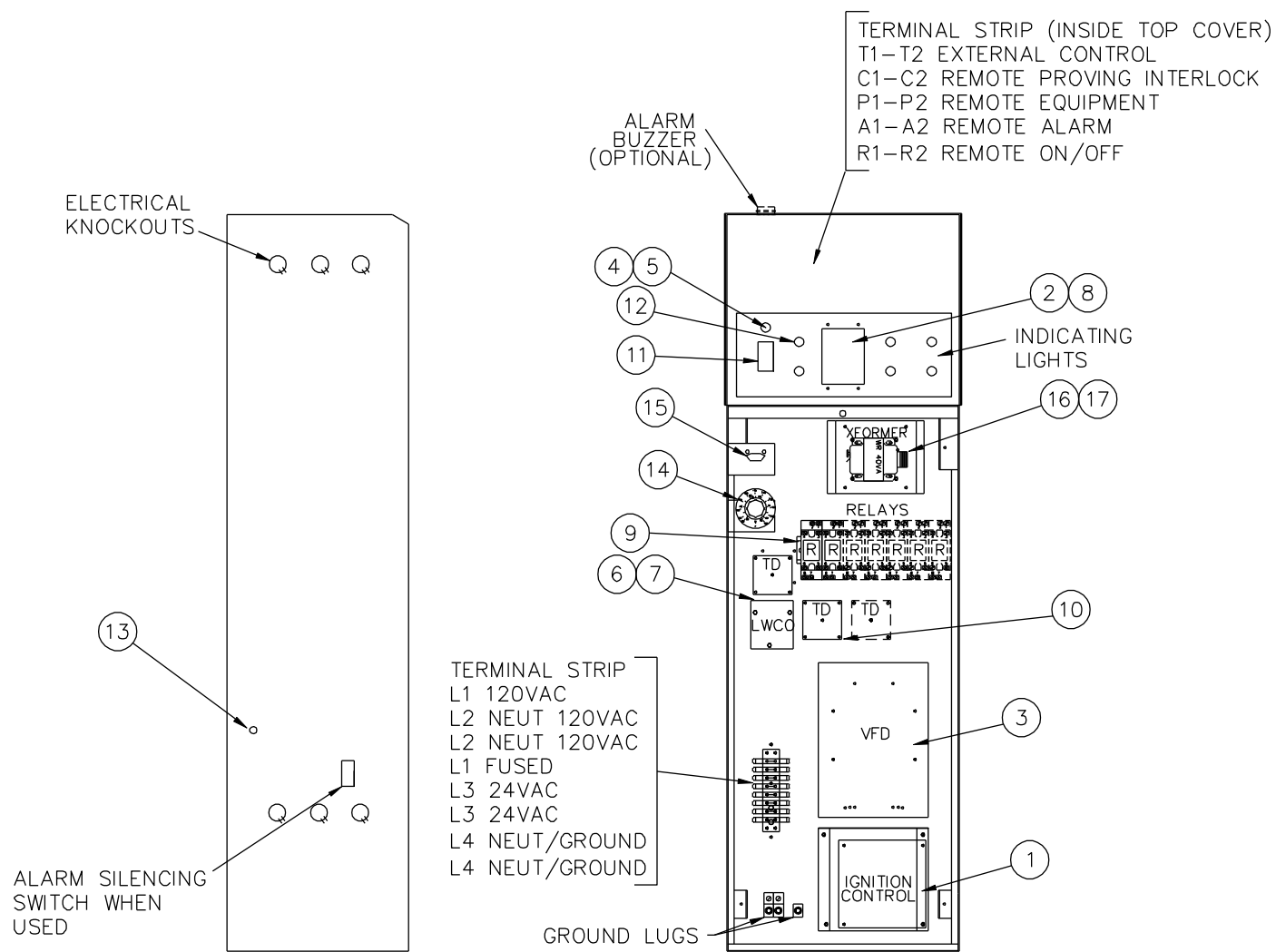

MAXIM 3 WATER HEATER

14.2 Control Panel Components (Optional components may not be included)

Key No.	Part No.	Description	Qty.	U/M
1	*	CONTROL, HOT SURFACE IGNITION FENWAL	1	EA
2	*	CONTROL, TEMPERATURE TEMPTRAC	1	EA
3	*	DRIVE, VARIABLE FREQUENCY AC EMERSON	1	EA
4	5613	FUSEHOLDER, PANEL TYPE #HTB-28I	1	EA
5	76267	FUSE, MDA 10 AMP BUSS 250V NO SUBSTITUTE	1	EA
6	129013	LWCO, PROTODESIGN #LW-3-C-1-A-03	1	EA
7	58154	PROBE, LWCO WARRICK #3L1D002.75 W/1/8 MPT 316 SST	1	EA
8	105266	PROBE, THERMOSTAT DIXELL #50DSS-NTC-1.5M SST	1	EA
9	115156	RELAY, DPDT 10A 24V OMRON #LY2-AC24 SQUARE BASE	*	EA
10	102835	RELAY, TIME DELAY ON SSAC #TDU3000A 24-120 VAC/DC 1 TO 102	*	EA
11	70565	SWITCH, CARLING #LTILA51-6SBLAM-NBL/125N/INDP BLACK W/AMBER	1	EA
12	70573	SWITCH, SPST N.C. MOMENTARY CONTACT SELECTA #SS229	*	EA
13	75908	SWITCH, SPST N.O. MOMENTARY CONTACT SELECTA #SS228	*	EA
14	129201	THERMOSTAT, JUMO #00660365 75-194 DEG W/DIAL 3.3 CAP, STR BULB	1	EA
15	*	THERMOSTAT, JUMO #6060002384 200 DEG AUTO RESET 3.3 CAP STR BULB	1	EA
16	120521	TRANSFORMER, CONTROL GE #9T58K2876 .150KVA 120/240V 12/24V 60 HZ	1	EA
17	75842	FUSE, MDA 6 AMP BUSS 250V	1	EA

* Contact factory for more information

MAXIM 3 WATER HEATER

14.3 Burner Assembly

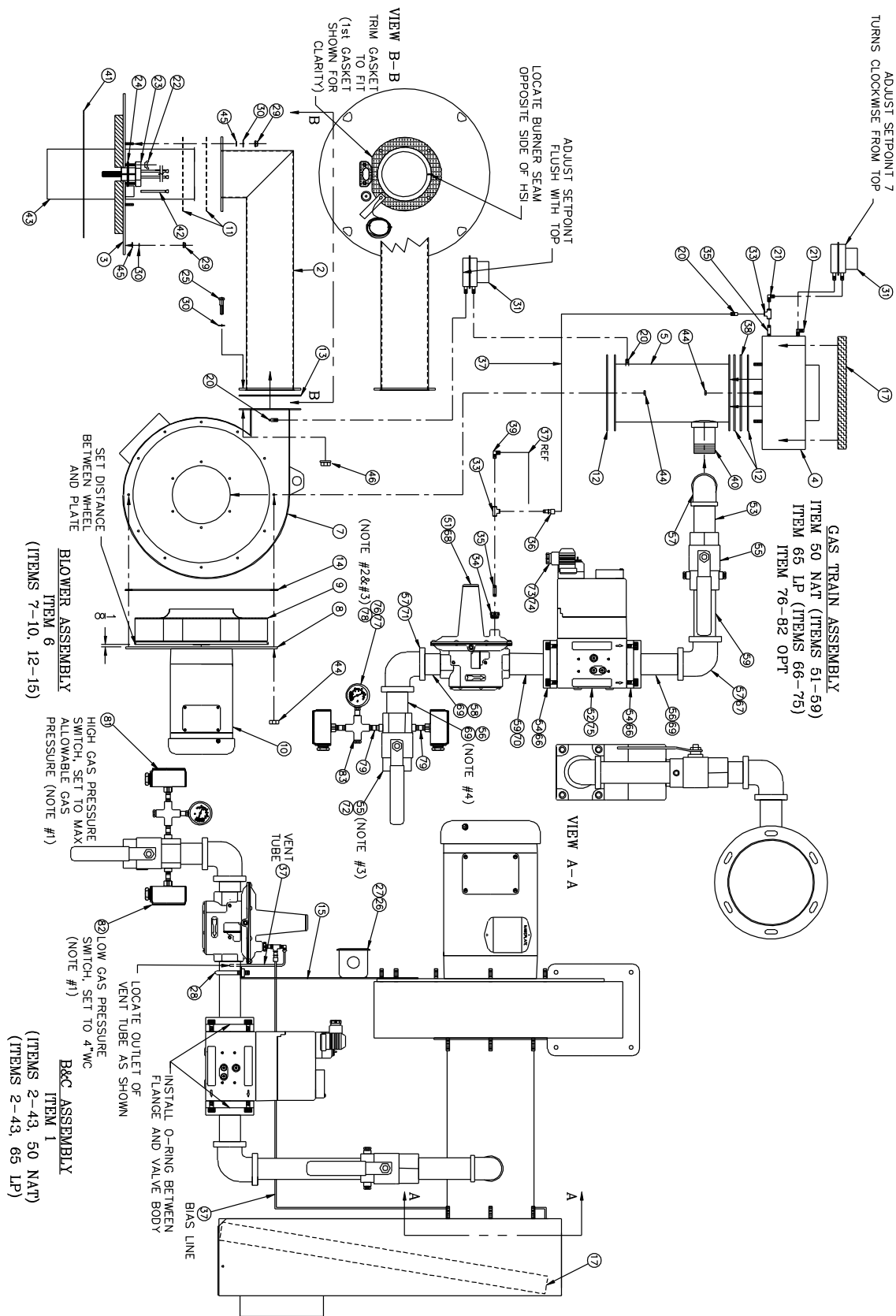

Optional components may or may not be shown

MAXIM 3 WATER HEATER

14.4 Burner Assembly Components (Optional components may not be included)

Item No.	Qty.	PVI Part No.	Description
BURNER ASSEMBLY COMPONENTS			
1		117188	B&C, 2000 MBtu MXIF/PVIF
2	1	117189	Assy, Burner PVIF 2000M
3	1	113752	Assy, Burner Top Plate / Return Tube 17
4	1	117190	Assy, Filter Box 12 X 24 PVIF
5	1	117191	Gas / Air Filter Tube
6	1	117192	Assy, Blower Housing FB14 2000M PVIF
7	1	117193	Housing, Blower FB14 PVIF
8	1	117194	Plate, Mtg Blower Motor 14 PVIF
9	1	110467	Wheel, Fan Punker HL45 plated
10	1	**	Motor, 1 1/2 hp BLDR
11	2	126509	Gasket, Flange Burner 1/8 232 Craneglas 5.750 ID
12	3	111037	Gasket, Blower Inlet 8 round
13	1	143357	Gasket, Blower Outlet 6 1/2 Square
14	4.00	104911	Strip, Adhesive 3/4 X 3/16 Vinyl Foam
15	1	117195	Support, Gas Train FB14 PVIF
16	35	3475	Nut, Hex 1/4 X 20NC Zinc plt
17	1	110265	Filter, Air 12 X 24
18	4	116637	Stud, Threaded 5/16 X 18NC X 2 316L SST
19	33	15607	Washer, Flat 1/4 plt
20	3	6480	Connector, 1/8 mpt X 1/4 comp
21	2	6493	Eil, 1/8 mpt X 1/4 comp
22	2	79972	Nut, Wing 1/4 X 20NC Steel
23	**	107775	Igniter, Hot Surface 271Y 1" Insertion
24	1	111791	Gasket, Igniter 232 Craneglas Y271
25	4	3425	Bolt, 5/16 X 18NC A 1 1/4
26	1	5616	Box, Handy 2 X 2 X 4
27	1	5617	Cover, Handy Box 2 X 2 X 4
28	1	100476	U-Bolt 1/4 X 2 X 3 1/4 w/plate
29	8	3476	Nut, Flange Lock 5/16 X 18NC
30	12	3495	Washer, Lock 5/16
31	**	59189	Switch, Air Proving Antunes SMD
32	35	3494	Washer, Lock 1/4 Plt
33	2	6437	Tee, Brass 1/8
34	1	6549	Bushing, Brass 1/2 X 1/8
35	2	6508	Nipple, Brass 1/8 X CL
36	1	6480	Connector, 1/8 mpt X 1/4 compression
37	20	3299	Tubing, Cut Aluminum 1/4 In
38	1	**	Orifice, Air Intake
39	1	5196	Snubber, 90 deg 1/4 tube x 1/8 mpt #80 Orifice
40	1	6057	Nipple, Black 1 1/2 x 4
41	1	126506	Insulation, Pyrolite 15 3/8 OD x 5 3/4 x 1
42	1	127816	Electrode, Flame Crown #26779 w/1/2 x 14 gland nut
43	1	SEE BOM	Burner, Worgas
44	36	141178	Nut, Lock Flange 1/4 x 20NC Nylon insert
45	8	3506	Washer, Flat 5/16 Zinc plt Use 138392
46	4	141498	Nut, Lock Flange 5/16 x 18NC Nylon insert

continued on next page...

MAXIM 3 WATER HEATER

BURNER GAS TRAIN COMPONENTS			
50	1	114530	Pkg, Gas Train 1 1/2 M X 3/8 P X 1 1/2 C
51	1	116921	Regulator, 1 1/2 Maxitrol #210EZ Zero Governor
52	1	102836	Valve, Gas Dungs DMV-D 703/6 24vac
53	**	6056	Nipple, Black 1 1/2 x 3 1/2
54	2	102838	Flange, Black 1 1/2 Dungs
55	2	45327	Valve, Shutoff 1 1/2 Gas Combu
56	2	69559	Nipple, Black 1 1/2 x 4 1/2
57	3	6168	Ell, Black 89 deg 1 1/2
58	1	6053	Nipple, Black 1 1/2 X 2
59	1	6059	Nipple, Black 1 1/2 X 6
LP BURNER GAS TRAIN COMPONENTS			
65	1	116124	Pkg, Gas Train 1 M X 1 1/2 C
66	2	76448	Flange, Valve 1 Dungs
67	1	6169	Ell, Black 90 deg 1 1/2 X 1
68	1	79524	Regulator, 1
69	3	6014	Nipple, Black 1 X 4
70	1	6018	Nipple, Black 1 X 7
71	1	6163	Ell, Black 90 deg 1
72	1	52823	Valve, Shutoff 1
73	1	117067	Adapter, Conduit 1/2 Dungs
74	1	114995	Connector, Din Dungs
75	1	102837	Valve, Gas Dungs
OPTIONAL GAS TRAIN COMPONENTS			
76	See BOM	39622 *	Gauge, Pressure
77	See BOM	22263 *	Cross, Black 1/4
78	See BOM	22264 *	Nipple, Black 1/4 x 4
79	See BOM	5972 *	Nipple, Black 1/4 x 1
80	See BOM	5973 *	Nipple, Black 1/4 x 2
81	See BOM	143481 *	Switch, Pressure HGP-G Antunes Man
82	See BOM	101201 *	Switch, Pressure LGP-G Antunes Man
83	See BOM	5940 *	Plug, Black 1/4

* Used on Nat & LP Gas Train

** Contact factory for more information

MAXIM 3 WATER HEATER

15 PERIODIC MAINTENANCE

Listed below are items that must be checked to ensure safe reliable operations. Maintenance must be performed by a qualified service or maintenance provider. To ensure proper maintenance, the following instructions should be posted near the appliance and maintained in legible condition. Verify proper operation after servicing.

WARNING: When servicing the controls, use exact, Factory authorized, replacement parts and label all wires prior to disconnection. Verify proper operation after servicing. Incorrect parts substitution and wiring errors can cause damage, improper operation, fire, carbon monoxide and other unexpected and unsafe conditions that could result in fire, injury or death.

1. Examine the appliance and venting system at least once a year. Check more often in first year to determine inspection interval.
 - a. Check all joints and pipe connections for tightness, corrosion or deterioration.
 - b. Check the electronic-ignition system for quick ignition and a proper flame signal.
 - c. Check all safety controls including thermostats for proper operation.
 - d. Check safety shut-off valves for operation and tightness.
 - e. Have the entire system, including, but not limited to, the burner, heat exchanger and venting system, periodically inspected by a qualified service agency.
2. Exposure to Dusty or Dirty Combustion Air: An appliance installed in a dust or dirt contaminated atmosphere will require an optional air inlet filter box. Replace the filter on a 3 to 6 month schedule or more often, based on severity of contamination. Without an inlet air filter, contaminants or non-combustible particulate matter such as dust, dirt, dryer lint, concrete dust, dry wall dust or the like can block burner ports and cause unsafe operation and a non-warrantable failure. Do not remove filter until a suitable replacement is available. The air filter is available through your PVI Industries dealer or use any standard capacity MERV 7, pleated air filter, 12"x24"x1".
3. Any sign of soot on the heat exchanger or in the flue indicates the need for a combustion inspection. Properly installed and adjusted units seldom need heat exchanger cleaning. If soot has formed, the most common causes are restricted combustion air or excessive gas. A blocked heat exchanger can cause unsafe operation and will reduce efficiency. To inspect and clean the heat exchanger, a qualified service agent or installer should use the procedures described in item 4, 5 & 6 below.
4. All gaskets on disassembled components must be replaced on reassembly with exact, Factory Authorized, replacement parts only. Gasket kits are available from your PVI Industries® Representative or by contacting PVI Industries®, LLC.
5. Burner and/or Heat Exchanger Inspection and Cleaning Procedure:
 - a. Turn off main power to unit.
 - b. Turn off gas supply.
 - c. Write notes and/or take pictures during this process to aid in correct reassembly.
 - d. Disconnect electrical the components by disconnecting the wires going to terminal strip in the top control enclosure and the respective conduit connections on the back of the control enclosure. If a wiring diagram is not attached to the back of the enclosure door or otherwise provided with the water heater, make careful notes of the locations for all the wires.
 - e. Remove the hot surface igniter, (HSI) from the burner. Be very careful not to bump the igniter element due to the fragility of the igniter.
 - f. Remove the nuts that secure the burner top plate to the burner flange and lift the burner top plate up until it is completely extracted from the burner.
 - g. Inspect top plate refractory for damage. The refractory should provide a tight seal against the top edge of the burner deck. The silicone foam gasket located on the top plate flange should also be checked for damage or excessive compression set.
 - h. With the burner top plate removed, inspect the deck surface of the burner for lent or other blockage carried in the fuel air stream. If blockage has accumulated, use brush to loosen debris and use a vacuum to remove from the burner cavities. Do not brush or scrub the metal fiber burner surface as this can cause permanent damage to the burner material.
 - i. Replace any damaged components and reassemble in reverse order. (4-5 ft/lbs).
 - j. Cycle unit and test to verify all safety and operating controls are properly functioning and the burner top plate flange is free of leaks.

MAXIM 3 WATER HEATER

6. The combustion air filter should be replaced every six months. If filter blockage becomes excessive the filter safety switch will not allow the burner to fire. To avoid nuisance shutdown in dirty environments, check and replace filter more frequently.
7. Inspect low water cutoffs (if equipped) and relief valves for proper operation at every six months, or more often if indicated by inspection.
8. Keep appliance area clear and free from combustible materials, gasoline and other flammable vapors and liquids.
9. Check frequently to be sure the flow of combustion and ventilation air is unobstructed to the appliance.
10. When electrical controls are serviced or replaced, label all connections as they are removed, to know the proper placement on the replacement part.
11. All replacement parts are available through your PVI Industries® Dealer. If you need assistance identifying or contacting your local dealer, you may contact PVI Industries, LLC directly at the address and telephone number located on the first and last page of this manual.
12. If the appliance is to be shut down for an extended period of time, the primary gas valve and the water supply should be shut off. When the appliance is returned to service, a thorough inspection of all utilities and general appliance condition should be conducted.

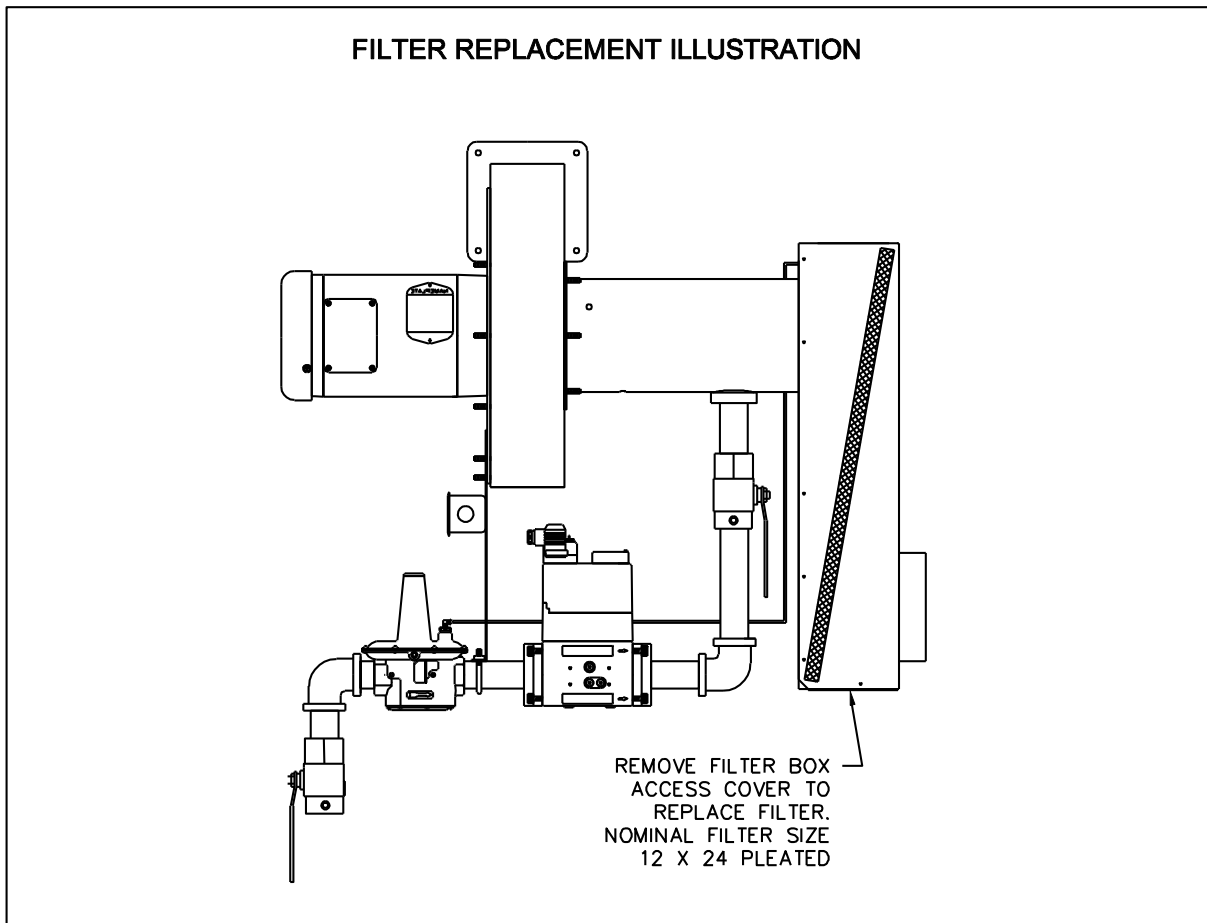

MAXIM 3 WATER HEATER

16 RECOMMENDED MAINTENANCE SCHEDULE

1. Annual Maintenance

- a. Check all joints and pipe connections for tightness, corrosion or deterioration.
- b. Check the electronic-ignition system for quick ignition and a proper flame signal.
- c. Check all safety controls including thermostats for proper operation.
- d. Check safety shut-off valves for operation and tightness.
- e. Test flame failure detection system.
- f. Test high limit and operating temperature controls.
- g. Conduct a combustion test.
- h. Perform leakage test on pilot and main gas valves.
- i. Test air switch functionality.

2. Semi-Annually

- a. Recalibrate all indicating and recording gauges.
- b. Check flame failure detection system components.
- c. Check firing rate control.
- d. Check piping and wiring of all interlocks and shutoff valves.
- e. Inspect burner components.
- f. Check igniter.
- g. Test high and low gas pressure interlocks (if equipped).
- h. If equipped, check air filter and replace if required.

3. Monthly Maintenance

- a. Test low-water cutoff device and alarm (if equipped).
- b. Check air filter (if equipped) every 3-6 months (sooner in dirty environment).
- c. Check flue, vent, stack, or outlet dampers.
- d. Check flame signal strength.
- e. Check flame failure detection system.
- f. Check firing rate control.
- g. Listen to and visually check the pilot and main fuel valves.

4. Daily Maintenance

- a. Check gauges, monitors, and indicators.
- b. Check instrument and equipment settings.

5. As Required

- a. Check drip leg and gas strainers.
- b. Test flame failure detection system.
- c. Test temperature and pressure relief valves in accordance with ASME Boiler and Pressure Vessel Code Sections VI & VII.
- d. Tank flush and cleanout. (Chauffage d'eau feront précipitants qui se déposent au fond de la cuve. Enlever ces précipitants deux fois par an ou plus souvent dans certains endroits.)

MAXIM 3 WATER HEATER

Warranty Forms Ship Separately with Each Product

MODEL NUMBER: _____

SERIAL NUMBER: _____

INSTALLATION DATE: _____

PVI INDUSTRIES®, LLC • 3209 Galvez Ave. • Fort Worth, Texas 76111 • Phone 1-800-433-5654 • www.pvi.com