

Rainwater Harvesting - Booster Pump

Job Name _____

Contractor _____

Job Location _____

Approval _____

Engineer _____

Contractor's P.O. No. _____

Approval _____

Representative _____

Tag _____

RWP-3-DVM Duplex Vertical Multistage Booster Pump Package

Specification

Watts RWP-3-DVM Duplex Multistage Booster Pump Package provides flow and pressure of rainwater in RainCycle commercial rainwater harvesting systems. Rated for flows up to 150 GPM and 125 PSI, this package includes Goulds e-SV vertical multistage pumps to maximize energy efficiency, service life and reduce maintenance.

The package is pre-plumbed on a stainless steel skid base for fast installation and includes check valves, safety pressure relief valves, isolation valves and pressure gauges. Variable speed drives with a 4-20mA pressure sensor are included when ordered with a Rainwater Control Station using a CR, VP, or VC control panel. The variable speed drive shall be installed on the Rainwater Control Station skid for ease of system installation, operation and maintenance.



Features

Booster Pump

- Top fill plug with air vent
- Replaceable mechanical seal without pump disassembly
- Self-aligning replaceable diffuser wear rings made from PPS glass filled technopolymer for maximum durability
- Tungsten carbide/silicone carbide intermediate bush bearing

Motor

- Standard NEMA TC Frame motors with open drip proof rating
- 3500 RPM nominal
- 1.25 Service Factor
- Motor insulation class F
- Energy efficient with EISA compliance

Skid Package

- Pre-plumbed with check valve, safety pressure relief valve, isolation valves and pressure gauges
- Includes duplex variable speed drives when ordered with a RainCycle Rainwater Control Station
- Durable stainless steel skid base
- Factory tested package

Ordering Base Code
RWP-3-DVM

Piping Material: (required)		
Suffix	Description	
-PVC	PVC Schedule 80	<input type="checkbox"/>
-CTL	Copper Type L	<input type="checkbox"/>
-304	304 Stainless Steel (schedule 10)	<input type="checkbox"/>
-316	316 Stainless Steel (schedule 10)	<input type="checkbox"/>

Electrical Supply: (required)		
Suffix	Description	
-208V	208V/3ph/60hz Supply Power	<input type="checkbox"/>
-240V	240V/3ph/60hz Supply Power	<input type="checkbox"/>
-480V	480V/3ph/60hz Supply Power	<input type="checkbox"/>
-575V	575V/3ph/60hz Supply Power	<input type="checkbox"/>

Watts product specifications in U.S. customary units and metric are approximate and are provided for reference only. For precise measurements, please contact Watts Technical Service. Watts reserves the right to change or modify product design, construction, specifications, or materials without prior notice and without incurring any obligation to make such changes and modifications on Watts products previously or subsequently sold.



Dimensions

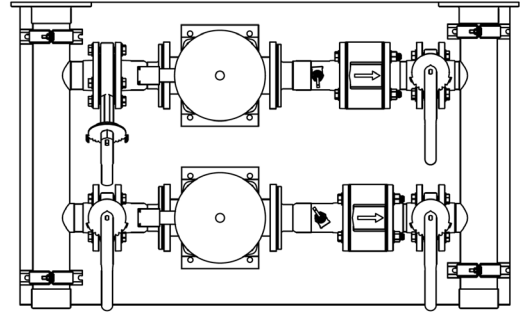
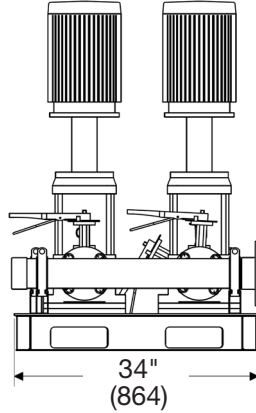
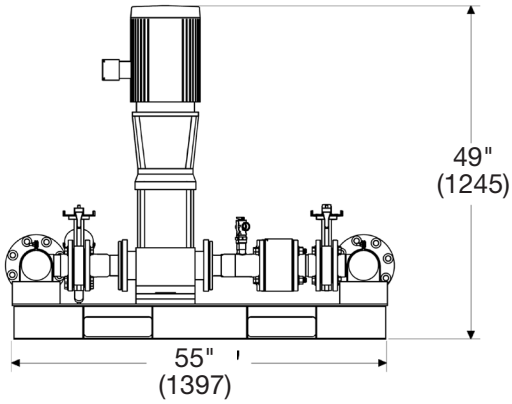

Complete Model #	RWP-3-DVM		
	Base Code	Piping	Electrical

Additional Information Required:

Required Flow		Gallons Per Minute
Required Total Dynamic Head (THD)*		Feet
Distance from storage tank**		Feet
Toilet Type		Flush Valve or Flapper
Pump Configuration		Lead/Lag or Alternating

* Prior to sizing, inform Watts Engineering if the booster pump will be installed at a distance greater than 100 feet from the Rainwater Control Station or at a different elevation.

Contact Watts Engineering for a comprehensive submittal package based upon the selected configuration.

NOTICE

The information contained herein is not intended to replace the full product installation and safety information available or the experience of a trained product installer. You are required to thoroughly read all installation instructions and product safety information before beginning the installation of this product.

WARNING

Rainwater supplied by Watts rainwater systems is non-potable water and is not intended for potable water applications. DO NOT DRINK WATER supplied from Watts rainwater systems and related equipment. Users shall determine the suitability of the product for the intended application before using.



USA: Tel: (978) 689-6066 • Fax: (978) 975-8350 • Watts.com

Canada: Tel: (905) 332-4090 • Fax: (905) 332-7068 • Watts.ca

Latin America: Tel: (52) 81-1001-8600 • Fax: (52) 81-8000-7091 • Watts.com