

Engineering Specification

Job Name _____

Contractor _____

Job Location _____

Approval _____

Engineer _____

Contractor's P.O. No. _____

Approval _____

Representative _____

Ball-Plex™ Cast Iron Screwed Ends Duplex Strainers

Model: 791SA, Class 125
Sizes: ¾" – 3" (20 – 80mm)

Strainers provide economical protection for costly pumps, meters, valves, and other similar mechanical equipment by straining foreign matter from the connected piping system. Installation of a strainer before mechanical equipment can ensure trouble free service and avoid costly shutdowns for repair or replacement of equipment damaged by foreign matter. The size of the perforation or mesh in the basket screen will determine the smallest particles captured. See Strainer Information section of the Mueller Steam Specialty Engineering binder for detailed information including sizes and materials available.

Typical Service

- Duplex Strainers are designed for use in fluid handling systems where the flow cannot be shut down for basket cleaning.
- Typical services include cooling water, compressors, condensers, fire lines, fuel lines, lubrication systems, salt and fresh water systems, chemical process systems, pump suction service, and more.
- Consider strainer body and screen material as well as gasket and seat materials for suitability for particular service.

Features

- Ball-Plex™ Duplex Strainers use 3-way balls as the diverter valves.
- Balls are 316SS for corrosion resistance, strength, and resistance to build-up of solids on the balls' surfaces.
- PTFE seats provide bubble-tight sealing, superior to metal seats in other designs. This eliminates potentially dangerous leakage into the chamber being cleaned.
- Two part body casting allows true and easy in-line service
- After removal of the cover and basket, all working parts are easily accessible even with the unit in line.
- The handle covers the pressurized chamber. This prevents accidental opening of the pressurized chamber, and allows easy access to the chamber to be cleaned.

Baskets

- Large open area ratios ensure minimum pressure drop across the unit.
- See Pressure Drop Charts in Technical Data section of the Mueller Steam Specialty Engineering Binder.

Mueller Steam Specialty product specifications in U.S. customary units and metric are approximate and are provided for reference only. For precise measurements, please contact Mueller Steam Specialty Technical Service. Mueller Steam Specialty reserves the right to change or modify product design, construction, specifications, or materials without prior notice and without incurring any obligation to make such changes and modifications on Mueller Steam Specialty products previously or subsequently sold.



Model 791SA

Pressure/Temperature–Non-Shock

Model	Material	Rating
791SA	Cast Iron	175psi @ -20°F to 150°F 12.07 bar @ 65.56°C 150psi @ 250°F 10.34 bar @ 121.11°C

*Max. temp. can be limited by gasket and seat material. Consult factory.

⚠ WARNING

Bolted Covers required above 150 psi or 200°F.

STANDARD (WATER)

MODEL	SIZES	MATERIAL	OPENING
791SA	¾" – 3"	304SS	.062 perf

NOTICE

The information contained herein is not intended to replace the full product installation and safety information available or the experience of a trained product installer. You are required to thoroughly read all installation instructions and product safety information before beginning the installation of this product.

Mueller Steam Specialty™

A WATTS Brand

Material

791FA	
Body	Cast Iron ASTM A126-B
Cover	Cast Iron ASTM A126-B
Seats	PTFE
O-Rings	Buna-N

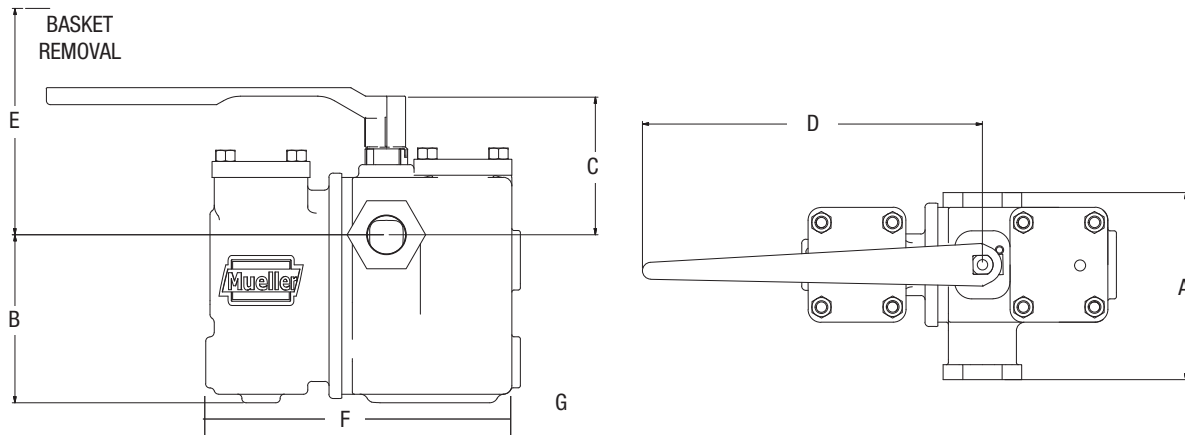

Model 791SA

Dimensions and Weights

SIZE		DIMENSIONS												WEIGHT			
		A		B		C		D		E Screen Removal		F		G (NPT)			
in.	mm	in.	mm	in.	mm	in.	mm	in.	mm	in.	mm	in.	mm	in.	mm	lbs.	kgs.
3/4"	20	5 1/2	140	4 15/16	125	4 5/8	118	10	254	7 3/4	197	10 3/16	259	3/4	20	30	13.6
1"	25	5 1/2	140	4 15/16	125	4 5/8	118	10	254	7 3/4	197	10 3/16	259	3/4	32	30	13.6
1 1/4"	32	7 1/2	191	6 3/4	171	4 3/8	111.1	10	254	10 3/8	264	12 3/4	324	1 1/4	32	53	24
1 1/2"	40	7 1/2	191	6 3/4	171	4 3/8	111.1	10	254	10 3/8	264	12 3/4	324	1 1/4	32	54	24
2"	50	10	254	8 3/16	208	7 1/8	181	20	508	12 5/8	321	16 3/8	416	1 1/4	40	105	47
2 1/2"	65	11 1/2	292	12	309	8 1/16	205	20	508	17 11/16	449	20 3/8	518	1 1/2	40	195	88
3"	80	11 1/2	292	12	309	8 1/16	205	20	508	17 11/16	449	20 3/8	518	1 1/2	40	200	90

Apply For Certified Drawings.

Limited Warranty: Mueller Steam Specialty warrants each product to be free from defects in material and workmanship under normal usage for a period of one year from the date of original shipment. In the event of such defects within the warranty period, the Company will, at its option, replace or recondition the product without charge. This shall constitute the sole and exclusive remedy for breach of warranty, and the Company shall not be responsible for any incidental, special or consequential damages, including without limitation, lost profits or the cost of repairing or replacing other property which is damaged if this product does not work properly, other costs resulting from labor charges, delays, vandalism, negligence, fouling caused by foreign material, damage from adverse water conditions, chemical, or any other circumstances over which the Company has no control. This warranty shall be invalidated by any abuse, misuse, misapplication or improper installation of the product. **THIS WARRANTY IS IN LIEU OF ALL OTHER WARRANTIES, EXPRESS OR IMPLIED, INCLUDING ANY IMPLIED WARRANTIES OF MERCHANTABILITY OR FITNESS FOR A PARTICULAR PURPOSE.** Any implied warranties that are imposed by law are limited in duration to one year.

Some States do not allow limitations on how long an implied warranty lasts, and some States do not allow the exclusion or limitation of incidental or consequential damages. Therefore the above limitations may not apply to you. This Limited Warranty gives you specific legal rights, and you may have other rights that vary from State to State. You should consult applicable state laws to determine your rights.



A WATTS Brand

USA: T: (800) 334-6259 • F: (800) 421-6772 • MuellerSteam.com

Latin America: T: (52) 55-4122-0138 • MuellerSteam.com