

Engineering Specification

Job Name _____
 Job Location _____
 Engineer _____
 Approval _____

Contractor _____
 Approval _____
 Contractor's P.O. No. _____
 Representative _____

Marine Bronze Duplex Strainer

Model: 690 Bronze, Class 125
Size: 3"

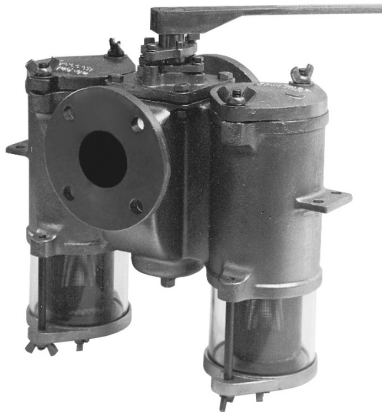

Model 690

Strainers provide positive and inexpensive protection for costly pumps, meters, valves, and other similar mechanical equipment by straining foreign matter from the connected piping system. Installation of a strainer before mechanical equipment can ensure trouble free service and avoid costly shutdowns for repair or replacement of equipment damaged by foreign matter. The size of the perforation or mesh in the basket screen will determine the smallest particles captured. See Strainer Information section of the Mueller Steam Specialty Engineering binder for detailed information including sizes and materials available.

Typical Service

- As with all duplex strainers, these are used where flow cannot be shut down for basket cleaning.
- These sight glass duplex strainers are typically used in engine cooling water systems in seawater and heat exchanger applications.
- When supplied with fine mesh lined baskets, they can be used to clarify potable water supplies.

Features

- Clear acrylic basket chambers allow direct visual inspection of the fluid flow and basket condition.
- Flow diversion is accomplished by a single tapered plug diverter that moves 90°, thereby opening one chamber while closing the other.
- Sight glass chambers and baskets are accessed for easy cleaning, inspection, and replacement by removal of two wing nuts.

Construction

- All body parts are heavy castings.
- Covers are bolted, clamped covers are available (limited to 150psig, 100°F).

Pressure/Temperature – Non-Shock	
Model	GWP
690	50psi @ 150°F 3.4bar @ 66°C

Not recommended for steam applications.

Baskets

Standard (Water)			
Model	Sizes	Material	Opening
690	3"	Monel	.062 perf

NOTICE

The information contained herein is not intended to replace the full product installation and safety information available or the experience of a trained product installer. You are required to thoroughly read all installation instructions and product safety information before beginning the installation of this product.

Mueller Steam Specialty product specifications in U.S. customary units and metric are approximate and are provided for reference only. For precise measurements, please contact Mueller Steam Specialty Technical Service. Mueller Steam Specialty reserves the right to change or modify product design, construction, specifications, or materials without prior notice and without incurring any obligation to make such changes and modifications on Mueller Steam Specialty products previously or subsequently sold.



A WATTS Brand

Material

690	
Body and Plug Covers	ASTM B-62 Bronze
Sight Glass Chambers	Acrylic Plastic
Cap Screws	Silicon Bronze
Baskets	Monel
Seals	Buna-N
Stem Packing	PTFE

Dimensions and Weights

SIZE		DIMENSIONS								WEIGHT							
		A		B		C		D		E Screen Removal		F		G			
in.	mm	in.	mm	in.	mm	in.	mm	in.	mm	in.	mm	in.	mm	in.	mm	lbs.	kgs.
3	80	11 ¹ / ₆	281	12 ¹ / ₂	318	19 ¹ / ₂	495	12	305	15 ⁷ / ₈	403	20 ⁵ / ₈	524	19 ¹ / ₂	495	155	70.4

Apply For Certified Drawings.

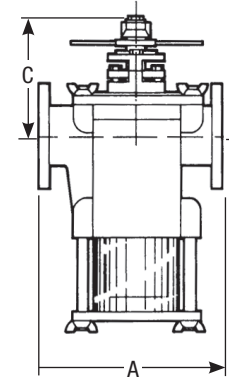
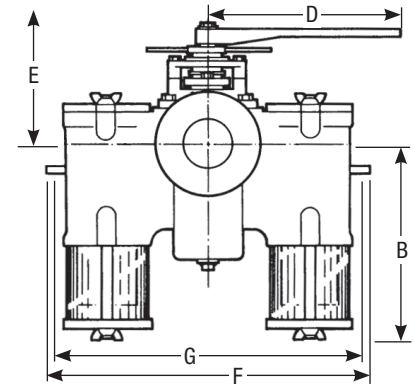

Model 690

Limited Warranty: Mueller Steam Specialty warrants each product to be free from defects in material and workmanship under normal usage for a period of one year from the date of original shipment. In the event of such defects within the warranty period, the Company will, at its option, replace or recondition the product without charge. This shall constitute the sole and exclusive remedy for breach of warranty, and the Company shall not be responsible for any incidental, special or consequential damages, including without limitation, lost profits or the cost of repairing or replacing other property which is damaged if this product does not work properly, other costs resulting from labor charges, delays, vandalism, negligence, fouling caused by foreign material, damage from adverse water conditions, chemical, or any other circumstances over which the Company has no control. This warranty shall be invalidated by any abuse, misuse, misapplication or improper installation of the product. **THIS WARRANTY IS IN LIEU OF ALL OTHER WARRANTIES, EXPRESS OR IMPLIED, INCLUDING ANY IMPLIED WARRANTIES OF MERCHANTABILITY OR FITNESS FOR A PARTICULAR PURPOSE.** Any implied warranties that are imposed by law are limited in duration to one year.

Some States do not allow limitations on how long an implied warranty lasts, and some States do not allow the exclusion or limitation of incidental or consequential damages. Therefore the above limitations may not apply to you. This Limited Warranty gives you specific legal rights, and you may have other rights that vary from State to State. You should consult applicable state laws to determine your rights.



A WATTS Brand

USA: T: (800) 334-6259 • F: (800) 421-6772 • MuellerSteam.com
Latin America: T: (52) 55-4122-0138 • MuellerSteam.com