

## Engineering Specification

Job Name \_\_\_\_\_

Contractor \_\_\_\_\_

Job Location \_\_\_\_\_

Approval \_\_\_\_\_

Engineer \_\_\_\_\_

Contractor's P.O. No. \_\_\_\_\_

Approval \_\_\_\_\_

Representative \_\_\_\_\_

# Aluminum Bronze, Carbon Steel, or Stainless Steel CHEXTER™ Check Valves

**Model 1601, Class 125**  
**Sizes: 2" - 36" (50 - 900mm)**

### Typical Services

Can be used in a vast number of industries and applications.

Included are:

- Commercial Construction (institutions, multi-story buildings, schools, etc.)
  - Chilled and hot water systems
  - Refrigeration, plumbing, air conditioning
- Industrial and Marine
  - Gas and liquid applications
  - Water filtration, oxygen systems, boiler feed lines
  - Centrifugal pump and compressor systems
- Utilities
  - All gas and liquid applications
- Process Industries (Refining, petro-chemical, mining, textiles, pulp and paper, etc.)
  - Variety of materials and trims for corrosive services

### Features

- Compact design with short face-to-face dimensions for minimum space requirements.
- Single moving part insures long, trouble-free service life.
- Seal-ring is one piece, easily replaceable in the field.
- Interchangeable parts for ease of maintenance.
- Operates fully at low pressure differential.
- Spring returns disc to fully closed position prior to reverse flow, minimizing water hammer.
- Disc is counter-weighted, utilizing gravity to additionally insure closure.
- Soft seal is located out of the flow path to reduce erosion effects.
- High  $C_V$  values due to aerodynamic disc shape and near full port opening.
  - Superior to other check valve designs, similar to Butterfly valves.



Model 1601  
Front



Open

### Pressure/Temperature - Non-Shock

Model	Material	Rating
1601-E	Aluminum Bronze	195psi @ 100°F 13 bar @ 38°C 140psi @ 450°F 10 bar @ 232°C
1601-A	Carbon Steel	285psi @ 100°F 20 bar @ 38°C 185psi @ 450°F 13 bar @ 232°C
1601-C	Stainless Steel	275psi @ 100°F 19 bar @ 38°C 185psi @ 450°F 13 bar @ 232°C

### Construction

- Robust cast body is wafer style, featuring compact face-to-face dimensions to fit in small spaces.
- Designed to fit within ANSI bolt circles.
- Variety of trim and seat materials are available, both soft and metal-to-metal.
  - Parts are interchangeable.
- Disc rotates on the hinge pin, creating very low pivot friction, so little wear in operation.

### Installation

- Can be installed horizontally or vertically.
  - Consult factory for downward vertical flow applications.
  - In horizontal applications, valve should be installed top up, with shaft aligned horizontally with the top up (hinge pin plugs are above the pipe centerline).
- Good piping practice recommends installing a distance of 5 to 10 pipe diameters from elbows, pumps, or others turbulence-creating devices.
- Mueller Steam Specialty strongly recommends the installation of a strainer ahead of the pump to ensure protection of both the pump and the valve from foreign particles.

### NOTICE

The information contained herein is not intended to replace the full product installation and safety information available or the experience of a trained product installer. You are required to thoroughly read all installation instructions and product safety information before beginning the installation of this product.

Mueller Steam Specialty product specifications in U.S. customary units and metric are approximate and are provided for reference only. For precise measurements, please contact Mueller Steam Specialty Technical Service. Mueller Steam Specialty reserves the right to change or modify product design, construction, specifications, or materials without prior notice and without incurring any obligation to make such changes and modifications on Mueller Steam Specialty products previously or subsequently sold.

**Mueller Steam Specialty™**

**A WATTS Brand**

## Materials

- See Information section of the CHEXTER™. Check section of the Mueller Steam Specialty Engineering binder for standard materials
- See Information section of the CHEXTER™. Check section of the Mueller Steam Engineering Specialty binder for Ordering instructions.

## Dimensions

### Raised Face And Flat Face Valves

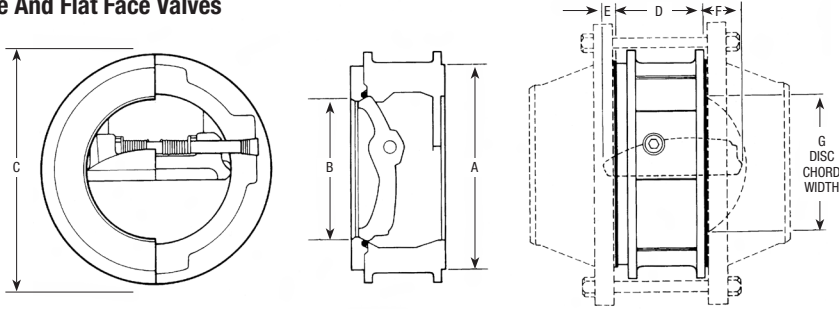

2" – 14" (50 – 350)

LINE SIZE		DIMENSIONS												
		A		B	C		D*		E		F		G	
				SAME VALVE FITS SCHEDULE 40 AND 80 LINE SIZES	125 & 150 CLASS									
in.	mm	in.	mm		in.	mm	in.	mm	in.	mm	in.	mm	in.	mm
2	50	3 <sup>5</sup> / <sub>8</sub>	92.1			4 <sup>1</sup> / <sub>8</sub>	104.8	1 <sup>1</sup> / <sub>2</sub>	38.1	1 <sup>1</sup> / <sub>8</sub>	3.2	1 <sup>1</sup> / <sub>2</sub>	12.7	1 <sup>15</sup> / <sub>16</sub>
2 <sup>1</sup> / <sub>2</sub>	65	4 <sup>1</sup> / <sub>8</sub>	104.8	4 <sup>7</sup> / <sub>8</sub>		123.8	1 <sup>15</sup> / <sub>16</sub>	49.2	1 <sup>1</sup> / <sub>8</sub>	3.2	9 <sup>1</sup> / <sub>16</sub>	14.3	2 <sup>3</sup> / <sub>16</sub>	55.6
3	80	5	127.0	5 <sup>5</sup> / <sub>8</sub>		136.5	2 <sup>1</sup> / <sub>8</sub>	54.0	1 <sup>1</sup> / <sub>4</sub>	6.4	3 <sup>1</sup> / <sub>4</sub>	19.1	2 <sup>7</sup> / <sub>8</sub>	73.0
4	100	6 <sup>3</sup> / <sub>16</sub>	157.2	6 <sup>7</sup> / <sub>8</sub>		174.6	2 <sup>3</sup> / <sub>4</sub>	69.9	1 <sup>1</sup> / <sub>4</sub>	6.4	1 <sup>1</sup> / <sub>8</sub>	28.6	3 <sup>7</sup> / <sub>8</sub>	98.4
5	125	7 <sup>5</sup> / <sub>16</sub>	185.7	7 <sup>3</sup> / <sub>4</sub>		196.9	3 <sup>1</sup> / <sub>2</sub>	88.9	9 <sup>1</sup> / <sub>16</sub>	14.3	1 <sup>3</sup> / <sub>8</sub>	34.9	4 <sup>1</sup> / <sub>16</sub>	103.2
6	150	8 <sup>1</sup> / <sub>2</sub>	215.9	8 <sup>3</sup> / <sub>4</sub>		222.3	4 <sup>1</sup> / <sub>8</sub>	104.8	3 <sup>1</sup> / <sub>4</sub>	19.1	1 <sup>1</sup> / <sub>4</sub>	31.8	4 <sup>15</sup> / <sub>16</sub>	125.4
8	200	10 <sup>5</sup> / <sub>8</sub>	269.9	11		279.4	5 <sup>3</sup> / <sub>8</sub>	136.5	1 <sup>1</sup> / <sub>16</sub>	27.0	1 <sup>15</sup> / <sub>16</sub>	49.2	6 <sup>7</sup> / <sub>8</sub>	174.6
10	250	12 <sup>3</sup> / <sub>4</sub>	323.9	13 <sup>3</sup> / <sub>8</sub>		339.7	6 <sup>1</sup> / <sub>16</sub>	169.9	1 <sup>7</sup> / <sub>16</sub>	38.1	2 <sup>3</sup> / <sub>8</sub>	60.3	8 <sup>3</sup> / <sub>8</sub>	212.7
12	300	15	381.0	16 <sup>1</sup> / <sub>8</sub>		409.6	8	203.2	2 <sup>1</sup> / <sub>16</sub>	52.4	2 <sup>7</sup> / <sub>16</sub>	61.9	9 <sup>3</sup> / <sub>8</sub>	238.1
14	350	16 <sup>1</sup> / <sub>4</sub>	412.8	17 <sup>3</sup> / <sub>4</sub>		450.9	8 <sup>3</sup> / <sub>4</sub>	222.3	1 <sup>1</sup> / <sub>2</sub>	38.1	2 <sup>1</sup> / <sub>4</sub>	57.2	9 <sup>1</sup> / <sub>4</sub>	235.0

\*\*D" dimensions (overall face-to-face) are for 125-600 Class.

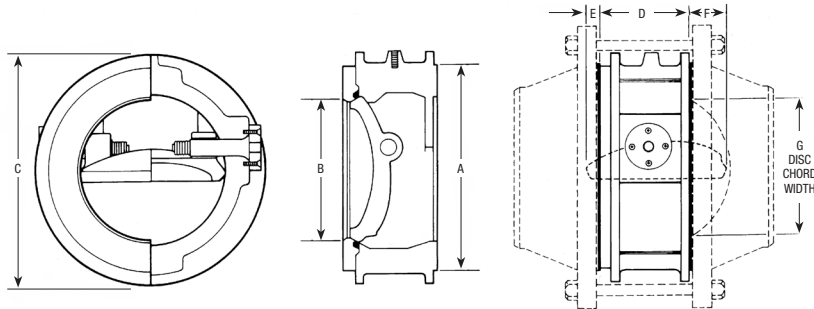

16" – 36" (400 – 900)

LINE SIZE		DIMENSIONS												
		A		B	C		D*		E		F		G	
				SAME VALVE FITS SCHEDULE 40 AND 80 LINE SIZES	125 & 150 CLASS									
in.	mm	in.	mm		in.	mm	in.	mm	in.	mm	in.	mm	in.	mm
16	400	18 <sup>1</sup> / <sub>2</sub>	469.9			20	508.0	9 <sup>1</sup> / <sub>4</sub>	235.0	1 <sup>13</sup> / <sub>16</sub>	46.0	4 <sup>5</sup> / <sub>8</sub>	117.5	13 <sup>3</sup> / <sub>4</sub>
18	450	21	533.4	21 <sup>1</sup> / <sub>4</sub>		539.8	10 <sup>3</sup> / <sub>8</sub>	263.5	1 <sup>1</sup> / <sub>2</sub>	38.1	5"	127.0	15 <sup>1</sup> / <sub>2</sub>	393.7
20	500	23	584.2	23 <sup>1</sup> / <sub>2</sub>		596.9	11 <sup>1</sup> / <sub>4</sub>	285.8	2 <sup>1</sup> / <sub>2</sub>	63.5	6 <sup>1</sup> / <sub>8</sub>	155.6	17 <sup>5</sup> / <sub>8</sub>	447.7
24	600	27 <sup>1</sup> / <sub>4</sub>	692.2	27 <sup>7</sup> / <sub>8</sub>		708.0	12 <sup>1</sup> / <sub>2</sub>	317.5	3 <sup>1</sup> / <sub>4</sub>	82.6	6 <sup>3</sup> / <sub>4</sub>	171.5	20 <sup>3</sup> / <sub>4</sub>	527.1
30	760	33 <sup>3</sup> / <sub>4</sub>	857.3	34 <sup>3</sup> / <sub>8</sub>		873.1	15 <sup>1</sup> / <sub>2</sub>	393.7	5 <sup>5</sup> / <sub>8</sub>	142.9	8 <sup>3</sup> / <sub>16</sub>	208.0	26 <sup>1</sup> / <sub>2</sub>	673.1
36	900	40 <sup>1</sup> / <sub>4</sub>	1022.4	40 <sup>7</sup> / <sub>8</sub>		1038.2	18"	457.2	5 <sup>5</sup> / <sub>16</sub>	134.9	12"	304.8	33 <sup>3</sup> / <sub>4</sub>	844.6

**Limited Warranty:** Mueller Steam Specialty warrants each product to be free from defects in material and workmanship under normal usage for a period of one year from the date of original shipment. In the event of such defects within the warranty period, the Company will, at its option, replace or recondition the product without charge. This shall constitute the sole and exclusive remedy for breach of warranty, and the Company shall not be responsible for any incidental, special or consequential damages, including without limitation, lost profits or the cost of repairing or replacing other property which is damaged if this product does not work properly, other costs resulting from labor charges, delays, vandalism, negligence, fouling caused by foreign material, damage from adverse water conditions, chemical, or any other circumstances over which the Company has no control. This warranty shall be invalidated by any abuse, misuse, misapplication or improper installation of the product. **THIS WARRANTY IS IN LIEU OF ALL OTHER WARRANTIES, EXPRESS OR IMPLIED, INCLUDING ANY IMPLIED WARRANTIES OF MERCHANTABILITY OR FITNESS FOR A PARTICULAR PURPOSE.** Any implied warranties that are imposed by law are limited in duration to one year.

Some States do not allow limitations on how long an implied warranty lasts, and some States do not allow the exclusion or limitation of incidental or consequential damages. Therefore the above limitations may not apply to you. This Limited Warranty gives you specific legal rights, and you may have other rights that vary from State to State. You should consult applicable state laws to determine your rights.



A WATTS Brand

USA: T: (800) 334-6259 • F: (800) 421-6772 • MuellerSteam.com

Latin America: T: (52) 55-4122-0138 • MuellerSteam.com