

## Engineering Specification

Job Name \_\_\_\_\_  
 Job Location \_\_\_\_\_  
 Engineer \_\_\_\_\_  
 Approval \_\_\_\_\_

Contractor \_\_\_\_\_  
 Approval \_\_\_\_\_  
 Contractor's P.O. No. \_\_\_\_\_  
 Representative \_\_\_\_\_

# Cast Iron Globe Check Style Foot Valve Assembly

**Models: 105MAP-FV, Class 125**  
**Sizes: 2" – 24" (50 – 600mm)**

### Typical Service

- Used at the intake side of a Suction Pipe and Pump.
- Design includes a Model 105 Globe Style Silent Check valve with a built-in strainer.
- The check valve opens when the pump is started, allowing liquid to enter the suction pipe and prime the pump. It closes as the pump stops and before a reverse flow condition develops. The prime to the pump is therefore maintained, eliminating the need to prime the pump each time it is started.
- The strainer removes unwanted debris from the intake, helping to protect the pump from damage.

### Features

- Spring closes the disc before flow reversal, preventing surge and water hammer.
- Mating surfaces of the disc and seat are hand lapped for best possible sealing.
- Disc is fully guided at top and bottom to insure alignment and sealing at any installation angle.
- Disc begins to open at .5 psi.
- Disc opens 1/3" per inch of line size, greater than similar competitive products, for enhanced flow.
- Bodies are designed to accommodate 110% flow of equivalent pipe size.

### Installation

- Can be installed horizontally, vertically or at any angle.
  - Normal installation is vertical with upward flow.
- A shutoff valve and an additional strainer will normally also be installed prior to the pump.
  - See Butterfly Valve Section for 87/88 Style Butterfly Valves for shutoff.
  - See Y Strainer or Basket Strainer Sections for various strainer options.

Mueller Steam Specialty product specifications in U.S. customary units and metric are approximate and are provided for reference only. For precise measurements, please contact Mueller Steam Specialty Technical Service. Mueller Steam Specialty reserves the right to change or modify product design, construction, specifications, or materials without prior notice and without incurring any obligation to make such changes and modifications on Mueller Steam Specialty products previously or subsequently sold.

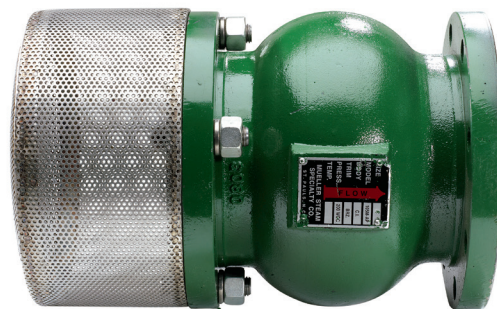

**Model 105MAP-FV**

### Pressure/Temperature Rating

Model	Sizes	Rating
105MAP-FV	2" – 12" (50 – 300mm)	200psi @ 150° F 13.8 bar @ 66°C
105MAP-FV	14" - 24" (350 – 600mm)	150psi @ 150° F 10.3 bar @ 66°C

Max. temp. can be limited by seat or spring material. Consult Factory.

Not Recommended for Steam Service.

### Construction

- Globe body design for greatest flow capacity in a foot valve.
- Integrally cast flanges for ease of installation, Class 125 pattern is standard, 250 is also available.
- Cast Iron body with bronze trim is standard. Other materials available on request, consult factory.
- 302SS springs are standard. Many variations in material and weight are available on specification, consult factory.
- Variety of trim and seat materials are available.
  - See "How To Order" chart.
- Standard strainer screen is 304SS perforated. Other screen materials, perforations and meshes are readily available as specified.

### NOTICE

The information contained herein is not intended to replace the full product installation and safety information available or the experience of a trained product installer. You are required to thoroughly read all installation instructions and product safety information before beginning the installation of this product.

**Mueller Steam Specialty™**

**A WATTS Brand**

## Ordering Information

- All pertinent information relating to the operating conditions for which the valve is intended should be supplied. These include operating pressure, temperature, flow rates, velocity, pump type, conveyance of corrosive fluids, etc.
- Barring specific information, standard springs and materials will be supplied.
- Other materials are available on request, including carbon steel, stainless steel, or other alloys.
- See Silent Check Valve Section for full listing of options available in the valve.
- See Strainer Information Section for a description of materials, perforations, and meshes available.
  - Special strainer designs can be supplied, consult factory.

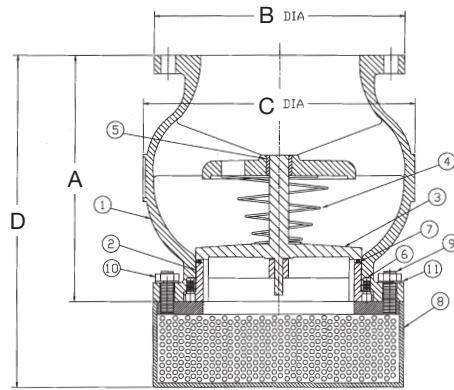

**Model 105MAP-FV**

## Dimensions and Flow Data

SIZE		DIMENSIONS							
		A		B		C		D	
in.	mm	in.	mm	in.	mm	in.	mm	in.	mm
<b>105MAP</b>									
2	50	6¼	159	6	152	4⅝	117	9¼	235
2½	65	7	178	7	178	5½	140	10	254
3	80	7½	191	7½	191	6¼	159	10¼	260
4	100	8½	216	9	229	8⅝	219	11½	292
5	125	9½	241	10	254	10	254	14½	368
6	150	10½	267	11	279	11⅞	283	15½	394
8	200	13½	343	13½	343	14⅝	371	19½	495
10	250	16¼	413	16	406	17⅞	441	24¼	616
12	300	20¼	514	19	483	21¾	552	28¼	718
14	350	22¾	578	21	533	24	610	32¾	832
16	400	24¾	629	23½	597	26⅞	670	34¾	883
18	450	22½	572	25	635	29⅞	752	34½	876
20	500	24	610	27½	699	32¾	832	36	914
24	600	24	610	32	813	37	940	40	1016
30	750	30	762	38¾	984	42½	1080	46	1168

Apply For Certified Drawings.

## Materials

		Description
Body	1	Cast Iron A126-GR. B
Seat	2	Bronze B-62
Disc	3	B-16 Bronze Plate
Spring	4	302 Stainless Steel ASTM A276-302
Bushing	5	Bronze ASTM B-98
Cap Screws	6	Socket HD 18-8 Stainless Steel
O-ring	7	Buna-N
Screen	8	304 Stainless Steel
Stud	9	A193-B7
Nut	10	A194-2H
Lockwasher	11	Carbon Steel

## Pressure Drop

- See Dimensional Data Chart for Pressure Drop and  $C_v$  values.

**ISO 9001-2008**  
CERTIFIED

**Limited Warranty:** Mueller Steam Specialty warrants each product to be free from defects in material and workmanship under normal usage for a period of one year from the date of original shipment. In the event of such defects within the warranty period, the Company will, at its option, replace or recondition the product without charge. This shall constitute the sole and exclusive remedy for breach of warranty, and the Company shall not be responsible for any incidental, special or consequential damages, including without limitation, lost profits or the cost of repairing or replacing other property which is damaged if this product does not work properly, other costs resulting from labor charges, delays, vandalism, negligence, fouling caused by foreign material, damage from adverse water conditions, chemical, or any other circumstances over which the Company has no control. This warranty shall be invalidated by any abuse, misuse, misapplication or improper installation of the product. **THIS WARRANTY IS IN LIEU OF ALL OTHER WARRANTIES, EXPRESS OR IMPLIED, INCLUDING ANY IMPLIED WARRANTIES OF MERCHANTABILITY OR FITNESS FOR A PARTICULAR PURPOSE.** Any implied warranties that are imposed by law are limited in duration to one year.

Some States do not allow limitations on how long an implied warranty lasts, and some States do not allow the exclusion or limitation of incidental or consequential damages. Therefore the above limitations may not apply to you. This Limited Warranty gives you specific legal rights, and you may have other rights that vary from State to State. You should consult applicable state laws to determine your rights.



**A WATTS Brand**