

Installation, Operation and Maintenance

3" Commercial Water Softeners

Series: PWS30, PWS30-2 & PWS30-P

WATTS[®]
pure water



PWS30 Simplex Systems



PWS30-2 Duplex Alternating Systems



PWS30-P Duplex, Triplex and Quadplex
Progressive Systems

Congratulations on your purchase of this Watts® commercial water softening solution.

You have made a great choice to protect your plumbing system against the damaging effects of hard water. This system has been engineered for trouble free operation and produced using top quality components. Simple programming, corrosion resistant mineral tank(s) and an easy to service design ensures this system will be durable and easy to maintain.

Thank You!

The Watts Team

Softened water provides a wide variety of benefits such as reducing the potential of lime scale formation in boilers, water heaters and heat exchangers to protecting the remainder of the plumbing system from costly maintenance and down time associated with the negative effects of hard water.

⚠ WARNING

Please read carefully before proceeding with installation. Your failure to follow any attached instructions or operating parameters may lead to the product's failure. Keep this Manual for future reference.

**⚠ WARNING**

If you are unsure about installing your Watts water softener contact a Watts representative or consult a professional water treatment dealer or plumber.

You are required to thoroughly read all installation instructions and product safety information before beginning the installation of this product. **FAILURE TO COMPLY WITH PROPER INSTALLATION AND MAINTENANCE INSTRUCTIONS COULD RESULT IN PRODUCT FAILURE WHICH CAN CAUSE PROPERTY DAMAGE, PERSONAL INJURY AND/OR DEATH.** Watts is not responsible for damages resulting from improper installation and/or maintenance. Local building or plumbing codes may require modifications to the information provided. You are required to consult the local building and plumbing codes prior to installation. If this information is not consistent with local building or plumbing codes, the local codes should be followed.

Save manual for future reference.

Refer to the enclosed for operating parameters to ensure proper use with your water supply.

- As with all plumbing projects, it is recommended that a trained professional water treatment dealer or contractor install the water conditioning system. Please follow all local plumbing codes for installing this water conditioning system.
- Inspect the water conditioning system for carrier shortage or shipping damage before beginning installation. Replace any damaged component immediately, before beginning installation.
- Use caution when installing soldered metal piping near the water conditioning system. Heat can adversely affect the system's components.
- Use only lead-free solder and flux for sweat-solder connections, as required by state, province and federal codes.
- Handle all components of the system with care. Do not drop, drag or turn components upside down.
- Be sure the floor under the system is clean, level and strong enough to support the system while in operation.
- Install the system in a protected area.
- Do not attempt to treat water over 110°F (43°C) or under 34°F (1°C) with the system.
- Always connect the system to the main water supply pipe before the water heater.
- Do not install in direct sunlight as overheating of electronics may occur and ultraviolet rays from the sun may cause damage.
- Do not use on water that is microbiologically unsafe or of unknown quality. This system will not make microbiologically unsafe water safe. Water that is unsafe must be treated separately from this conditioner.
- Operating ambient temperature: 34° to 100°F (1° to 43°C).
- Operating water pressure range : 25 to 125psi (171 kPa to 8.6 bar).
- All plumbing connections to the system should be made using industry accepted best practices. Plumbing tape or paste may be used on metal inlet and outlet plumbing connections. Do not use paste type pipe thread sealants on the system's plastic plumbing connections.

- Do not use petroleum-based lubricants such as Vaseline, oils or hydrocarbon-based lubricants on O-rings or valve seals. Use only 100% silicone lubricants.
- Use only the power transformer supplied with this water conditioning system.
- All electrical connections must be completed according to local codes.
- The power outlet must be grounded.
- For installations where plastic plumbing is used, install an appropriate grounding strap across the inlet and outlet piping of the building's metal plumbing to ensure that a proper ground is maintained.
- To disconnect power, unplug the AC adapter from its power source.
- Observe drain line requirements.
- Support the full weight of the plumbing system with pipe hangers or other means.
- Do not allow this water conditioning system to freeze. Damage from freezing will void this water conditioning system's warranty.
- It is established that when daytime water pressure exceeds 80psi (5.5 bar), the maximum pressure rating of 125psi (8.6 bar) can be exceeded. A pressure regulator must be installed on this system or warranty is voided.
- Periodic cleaning and maintenance is required for system to function properly.
- Observe all warnings that appear in this manual.
- Keep the media tank in the upright position. Do not turn upside down or drop. Turning the tank upside down or laying the tank on its side can cause media to enter the valve.
- Use only regenerants designed for water conditioning. Do not use ice melting salt, block salt or rock salt.

How To Use This Manual

This installation manual is designed to guide the installer through the process of installing and starting up this commercial water conditioning systems.

This manual is a reference and will not include every system installation situation. The person installing this equipment should have:

- Training on the control valve.
- Knowledge of water conditioning and how to determine proper control settings.
- Adequate plumbing skills.

⚠ WARNING

Do not use with water that is microbiologically unsafe or of unknown quality without adequate disinfection before or after the system.

Table of Contents	Page
Safety Information	3
How To Use This Manual	3
Introduction	4
Project Data Sheet	5
System Specifications	6-7
Set Up	8
Operating Parameters	8
System Installation	9-10
Start Up Instructions	11
Installation Diagrams - Series PWS30 Simplex Systems	12
Installation Diagrams - Series PWS30-2 Duplex Alternating Systems	13
Installation Diagrams - Series PWS30-P Progressive 2-4 Tank Systems	14
Controller Electrical Connections	15
Wiring Diagram	16
NXT2 Controller Programming and Operation	17
Controller Display	18
Controller Operation	19
Controller Features	20-21
Master Programming Mode Flow Chart	22-23
User Programming Mode Flow Chart	23
Diagnostic Programming Mode Flow Chart	24
Time of Day Programming Mode Flow Chart	25
NXT2 Programming Parameters and Ranges	26
Replacing the Media	27-28
Replacement Parts - Major System Components	29-30
Replacement Parts - 3900 Upper Powerhead	31
Replacement Parts - NXT2 Controller Assembly	32
NXT to NXT2 Conversion Kit	33
Replacement Parts - 3900 Lower Powerhead	34
Replacement Parts - 3900 Control Valve Body	35
Replacement Parts - 1800 Brine Valve	36
Replacement Parts - 1800 Injector Assembly	37
Replacement Parts - 3" Stainless Steel Electronic Meter	38
Troubleshooting	39-40
Water Softener Flow Diagrams	41-42
Flow Data and Injector Draw Rates - Down Flow	43
Injector Nozzle and Throat Chart for 1800 Brine Systems	44
Warranty	44

Introduction

Principals of Softening- Ion Exchange

In nature, water acts as a solvent that dissolves substances it comes in contact with such as solid rock. When water dissolves limestone rock, which is composed of calcium and magnesium, the solid calcium and magnesium become ions. This means they have been dissolved into the water and are now a liquid. An ion with a positive electrical charge is called a cation. Calcium and magnesium hardness ions in water are positively charged cations. When water dissolves enough calcium and magnesium hardness cations it is classified as hard water, which can cause lime scale build up in plumbing systems, water spots, and an increase in soap and cleaning product usage.

Ion exchange water softening is a process where an ion exchange resin is used to effectively exchange calcium and magnesium hardness cations for sodium cations in the water.

New, or freshly regenerated, ion exchange resin is saturated with sodium cations. As calcium and magnesium hardness cations come in contact with the ion exchange resin, they attach to the resin and sodium cations are released into the water. This is possible because the hardness cation are more attracted to the ion exchange resin than the sodium cations. Therefore, scale forming calcium and magnesium cations have been exchanged for non-scale forming sodium cations as the water is treated. If the calcium and magnesium content of the water is reduced to less than 17.1 mg/L, that water is classified as soft water.

Eventually the ion exchange resin will become exhausted, depleted of sodium, and will need to be regenerated with a sodium brine solution to restore its capacity to soften water. This system includes a flow meter to track treated water volume and initiate the regeneration process before resin exhaustion occurs.

Regeneration occurs automatically and consists of 5 steps:

Step 1- Backwash

Approximate Duration 10 Minutes- Fresh water flow is directed upward through the resin bed, to remove solid particles the resin bed has captured, sending them to drain.

Step 2- Brine Draw

Approximate Duration 15-20 Minutes- Brine water is drawn from the brine tank, rinsed over the ion exchange resin, driving away the calcium and magnesium cations and restoring sodium cations within the resin. Calcium and magnesium is sent to drain.

Step 3- Slow Rinse

Approximate Duration 40-45 Minutes- Once the brine tank is emptied of brine water, fresh water will continue to rinse over the resin and rinse calcium and magnesium cations to drain.

Step 4- Rapid Rinse

Approximate Duration 10 Minutes- After the conclusion of slow rinse, fresh water will rinse over the resin to ensure any residual sodium brine has been cleaned from the resin before it returns to service.

At the conclusion of Rapid Rinse:

Simplex single tank systems return to the "In Service" position. Multi tank systems remain in the "Stand By" position.

Step 5- Brine Tank Refill

Approximate Duration User Adjustable- In this final step of regeneration, water is added back into the brine tank so that a brine solution can be prepared for the next regeneration.

Project Data Sheet

Job Details

Job Number: _____

Model Number/Serial Number: _____

Water Hardness: _____ ppm or gpg

Capacity Per Unit: _____

Mineral Tank Size: _____ Diameter: _____ Height: _____

Salt Setting per Regeneration: _____

Regenerant Flow: _____ Upflow _____ Downflow _____

1. Meter Size:

A. ¾" Paddle Wheel

B. ¾" Turbine

C. 1" Paddle Wheel

D. 1" Turbine

E. 1½" Electronic Inline Plastic Turbine

F. 1½" Paddle Wheel

G. 2" or 3" Paddle Wheel: Stainless Steel _____ Brass _____ Plastic _____

H. Generic _____ Pulse Count _____ Meter Size _____

2. System Type:

A. System #4: 1 Mineral Tank, 1 Meter, Immediate, or Delayed Regeneration

B. System #7: 2 Mineral Tanks, 1 Meter, Immediate Regeneration

C. System #14: 2-8 Mineral Tanks, 2-8 Meters, Immediate Regeneration,

Progressive Flow Tank Staging- GPM Threshold for Progressive

Feature _____

D. _____ Other: System # Description _____

3. Controller Program Settings:

A. Backwash: _____ Minutes

B. Brine and Slow Rinse: _____ Minutes

C. Rapid Rinse: _____ Minutes

D. Brine Tank Refill: _____ Minutes

E. Pause Time: _____ Minutes

4. Drain Line Flow Control: _____ gpm

5. Brine Line Flow Control: _____ gpm

6. Injector Size#: _____

7. Water Pressure: _____

8. Water Temperature: _____

System Specifications

Dimensions - Weights

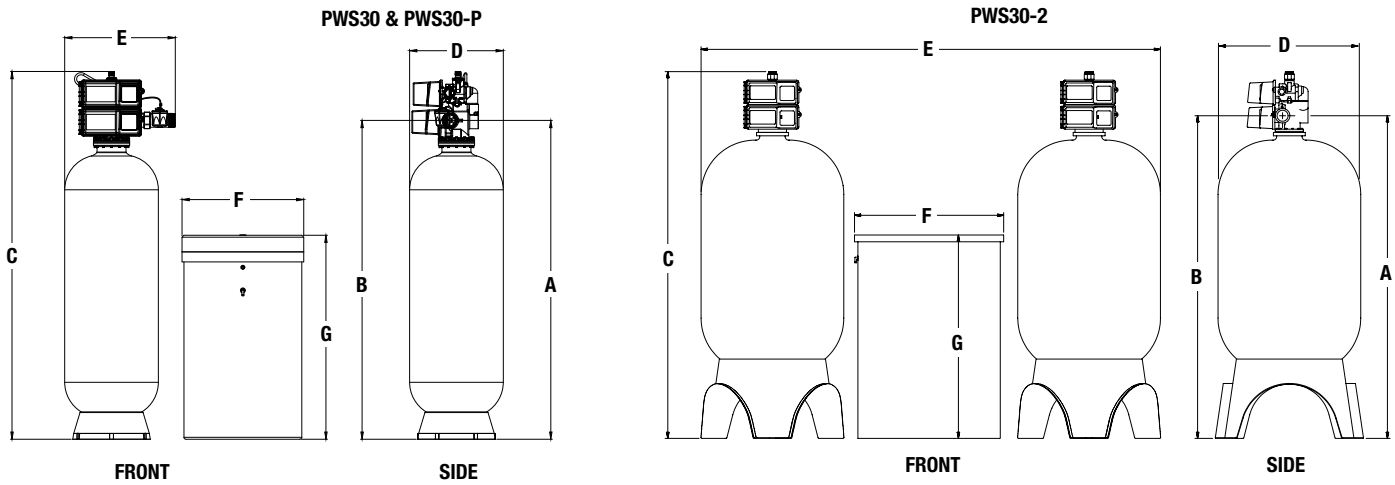

NOTICE

Dimensional data is for a single mineral tank system ONLY. PWS30-P models are composed of multiple PWS30 systems which can be arranged accordingly to suit floor space availability. See Space Required in table below for single tank systems and estimate 2 spaces for duplex, 3 spaces for triplex and 4 spaces for quadplex PWS30-P series systems.

Series PWS30 & PWS30-P

MODEL NO.	DIMENSIONS												SHIPPING WEIGHT lbs		
	A		B		C		D		E		F			G	
	mm	in.	in.	mm	in.	mm	in.	mm	in.	mm	in.	mm		in.	mm
PWS30151H11	79 ⁷ / ₁₆	2017	79 ⁷ / ₁₆	2017	95 ¹ / ₄	2419	24 ¹ / ₂	622	28 ⁵ / ₈	733	30	762	50	1270	1070
PWS30151I11	81 ⁷ / ₁₆	2068	81 ⁷ / ₁₆	2068	96 ¹ / ₄	2457	30 ³ / ₈	765	31 ³ / ₈	797	39	991	48	1219	1600
PWS30151J11	87 ¹ / ₄	2216	87 ¹ / ₄	2216	101	2565	36 ¹ / ₈	917	36 ¹ / ₈	917	39	991	60	1524	2015
PWS30151K11	95 ¹ / ₄	2419	95 ¹ / ₄	2419	108	2743	44	1118	44	1118	42	1067	60	1524	3245
PWS30151L11	99 ⁵ / ₈	2530	99 ⁵ / ₈	2530	112 ³ / ₈	2854	50 ³ / ₈	1280	50 ³ / ₈	1280	50	1270	60	1524	4295

Series PWS30-2

MODEL NO.	DIMENSIONS												SHIPPING WEIGHT lbs		
	A		B		C		D		E		F			G	
	in.	mm	in.	mm	in.	mm	in.	mm	in.	mm	in.	mm		in.	mm
PWS30151H21	79 ⁷ / ₁₆	2017	79 ⁷ / ₁₆	2017	95 ¹ / ₄	2419	24 ¹ / ₂	622	85	2159	30	762	50	1270	2070
PWS30151I21	81 ⁷ / ₁₆	2068	81 ⁷ / ₁₆	2068	96 ³ / ₄	2457	30 ³ / ₈	765	100	2540	39	991	48	1219	3000
PWS30151J21	87 ¹ / ₄	2216	87 ¹ / ₄	2216	101	2565	36 ¹ / ₈	917	111	2819	39	991	60	1524	4015
PWS30151K21	95 ¹ / ₄	2419	95 ¹ / ₄	2419	108	2743	44	1118	126	3200	42	1067	60	1524	6245
PWS30151L21	99 ⁵ / ₈	2530	99 ⁵ / ₈	2530	112 ³ / ₈	2854	50 ³ / ₈	1280	150	3810	50	1270	60	1524	8295

NOTICE

Service gpm is for a single mineral tank system ONLY. For PWS30-P Series systems, you will need to multiply the Service gpm by (x2) for Duplex, (x3) for Triplex and (x4) for Quadplex systems.

Specifications

MODEL NO.	MINERAL TANK			BRINE TANK		SOFTENING CAPACITY		LBS. SALT PER REGENERATION		FLOW RATE & PRESSURE		
	TANK SIZE	RESIN FT ³	GRAVEL (LBS) 1/4X1/8 / #20	TANK SIZE	SALT FILL	MAX	MIN	MAX	MIN	SERV GPM	DROP PSI	BKW GPM
	PWS30151H11	24" X 72"	10	100 / 100	30" X 50"	1400	300 K	200 K	150	60	120/170	15/25
PWS30151I11	30" X 72"	15	200 / 200	39" X 48"	2200	450 K	300 K	225	90	158/212	15/25	25
PWS30151J11	36" X 72"	20	300 / 200	39" X 60"	2700	600 K	400 K	300	120	185/250	15/25	35
PWS30151K11	42" X 72"	30	400 / 300	42" X 60"	3100	900 K	600 K	450	180	200/268	15/25	45
PWS30151L11	48" X 72"	35	700 / 300	50" X 60"	4500	1050 K	700 K	525	210	213/280	15/25	60

System Specifications

General System Information for 3" Simplex (PWS30) and Duplex Alternating (PWS30-2) Softeners

MODEL NO.	ORDERING CODE	DESCRIPTION	SPACE REQUIRED D X W X H	SHIPPING WEIGHT LBS
PWS30151H11	7100045	10 Cubic Foot 3" Simplex Softener with Flow Meter	39" X 74" X 103"	1070
PWS30151I11	7100046	15 Cubic Foot 3" Simplex Softener with Flow Meter	39" X 77" X 107"	1600
PWS30151J11	7100047	20 Cubic Foot 3" Simplex Softener with Flow Meter	39" X 81" X 109"	2015
PWS30151K11	7100048	30 Cubic Foot 3" Simplex Softener with Flow Meter	42" X 90" X 117"	3245
PWS30151L11	7100049	35 Cubic Foot 3" Simplex Softener with Flow Meter	50" X 104" X 117"	4295
PWS30151H21	7100050	10 Cubic Foot 3" Duplex Alternating Softener with Flow Meter	39" X 100" X 103"	2070
PWS30151I21	7100051	15 Cubic Foot 3" Duplex Alternating Softener with Flow Meter	39" X 117" X 107"	3000
PWS30151J21	7100052	20 Cubic Foot 3" Duplex Alternating Softener with Flow Meter	39" X 129" X 109"	4015
PWS30151K21	7100053	30 Cubic Foot 3" Duplex Alternating Softener with Flow Meter	42" X 144" X 117"	6245
PWS30151L21	7100054	35 Cubic Foot 3" Duplex Alternating Softener with Flow Meter	50" X 164" X 117"	8295

General System Information for 3" Duplex Progressive (PWS30-P) Softeners

MODEL NO.	ORDERING CODE	DESCRIPTION	SPACE REQUIRED D X W X H	SHIPPING WEIGHT LBS
PWS30151H22	7100651	10 Cubic Foot 3" Progressive Duplex Softener with Flow Meters	59" x 82" x 106"	2140
PWS30151I22	7100652	15 Cubic Foot 3" Progressive Duplex Softener with Flow Meters	74" x 92" x 107"	3200
PWS30151J22	7100653	20 Cubic Foot 3" Progressive Duplex Softener with Flow Meters	80" x 98" x 111"	4030
PWS30151K22	7100654	30 Cubic Foot 3" Progressive Duplex Softener with Flow Meters	90" x 100" x 118"	6490
PWS30151L22	7100655	35 Cubic Foot 3" Progressive Duplex Softener with Flow Meters	106" x 114" x 123"	8590

General System Information for 3" Triplex Progressive (PWS30-P) Softeners

MODEL NO.	ORDERING CODE	DESCRIPTION	SPACE REQUIRED D X W X H	SHIPPING WEIGHT LBS
PWS30151H33	7100656	10 Cubic Foot 3" Progressive Triplex Softener with Flow Meters	59" x 131" x 106"	3210
PWS30151I33	7100657	15 Cubic Foot 3" Progressive Triplex Softener with Flow Meters	74" x 137" x 107"	4800
PWS30151J33	7100658	20 Cubic Foot 3" Progressive Triplex Softener with Flow Meters	80" x 147" x 111"	6045
PWS30151K33	7100659	30 Cubic Foot 3" Progressive Triplex Softener with Flow Meters	90" x 150" x 118"	9735
PWS30151L33	7100660	35 Cubic Foot 3" Progressive Triplex Softener with Flow Meters	106" x 171" x 123"	12885

General System Information for 3" Quadplex Progressive (PWS30-P) Softeners

MODEL NO.	ORDERING CODE	DESCRIPTION	SPACE REQUIRED D X W X H	SHIPPING WEIGHT LBS
PWS30151H44	7100757	10 Cubic Foot 3" Progressive Quadplex Softener with Flow Meters	59" x 175" x 106"	4280
PWS30151I44	7100758	15 Cubic Foot 3" Progressive Quadplex Softener with Flow Meters	74" x 180" x 107"	6400
PWS30151J44	7100759	20 Cubic Foot 3" Progressive Quadplex Softener with Flow Meters	80" x 190" x 111"	8060
PWS30151K44	7100760	30 Cubic Foot 3" Progressive Quadplex Softener with Flow Meters	90" x 200" x 118"	12980
PWS30151L44	7100761	35 Cubic Foot 3" Progressive Quadplex Softener with Flow Meters	106" x 228" x 123"	17180

Notes: Capacities are based on resin manufacturer's data and are dependent upon influent water TDS, temperature, bed depth, and flow rates. Feed water must be free of oil and color. Pipe size, tank size, and space requirements are in inches. Capacities and flow rates expressed above are per tank. For Series PWS30-P systems, service flow rates are stated with all mineral tanks in service. During regeneration, the overall system service flow rate will be reduced by a factor of one mineral tank and must be sized accordingly. Flow rates listed at 25psi drops are for intermittent peak flow rates and are not to be used as continuous flows.

Set Up

Unpack system and make sure all components are accounted for according to the diagram below according to your specific series number. If any components are missing or damaged contact your Watts representative. If they can not be reached contact Watts customer service at 800-224-1299.

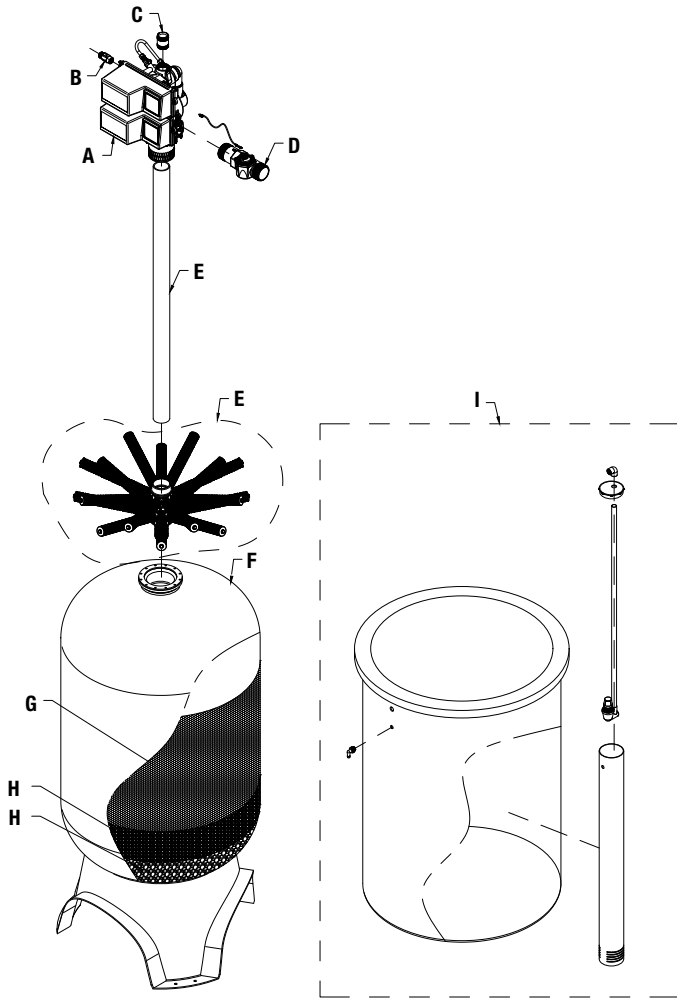

Operating Parameters

pH 6 to 10
 Hardness (maximum) Depends on customer's acceptable hardness leakage level
 Water Pressure 25psi to 125psi (171 kPa to 8.6 bar)
 Temperature 34 - 110°F (1 - 43°C)
 Free Chlorine (maximum) 1 mg/L
 Iron (maximum) 1 mg/L
 Oil and H₂S None Allowed
 Turbidity Less than 5.0 NTU
 Total Dissolved Solids Must be below 750 mg/L for the softener to produce less than 1 grain per gallon soft water
 Minimum Ambient Temperature 34°F/1°C
 Maximum Ambient Temperature 120°F/52°C
 Maximum Humidity 75%
 Power Supply Input Voltage 100-240 VAC
 Power Supply Input Frequency 50/60 Hz
 Power Supply Output Voltage 24 VDC
 Power Supply Output Current 2.7 amps (per control valve)
 Maximum Altitude 2,000 meters above sea level
 Water known to have heavy loads of dirt and debris may require pre-filtration prior to the water softening system.
 For all other guideline information please contact your Watts representative.

QUANTITY OF MAJOR COMPONENTS BY SERIES

COMPONENT LABEL	COMPONENT	PWS30 SIMPLEX	PWS30-2 DUPLEX ALTERNATING	PWS30-P DUPLEX PROGRESSIVE	PWS30-P TRIPLEX PROGRESSIVE	PWS30-P QUADPLEX PROGRESSIVE
A	Number of Control Valves	1	2	2	3	4
B	Number of Brine Line Flow Controllers*	1	1	2	3	4
C	Number of Drain Line Flow Controllers*	1	2	2	3	4
D	Number of Flow Meters	1	1	2	3	4
E	Number of Distributor Tubes*	1	2	2	3	4
F	Number of Mineral Tanks	1	2	2	3	4
G	Resin**	Quantity Varies Depending On System Size				
H	Gravel**	Quantity Varies Depending On System Size				
I	Number of Brine Tanks	1	1	2	3	4

*Drain line and brine line flow controllers may come factory assembled on control valve's drain port depending on size. Carefully inspect control valve and brine tank packaging for these items before discarding any packaging. Distributor tubes ship inside mineral tanks.

**Resin and gravel are supplied in bulk on pallets. The proper amount is supplied for the system.

Divide resin and gravel equally between the number of mineral tanks. See page 6 Specifications table for media quantity by tank size.

System Installation

Pre-Installation Considerations

- A minimum of 25psi of water pressure is required for regeneration valve to operate effectively.
- A continuous 115 volt, 60 Hertz current supply is required. Make certain the current supply is always hot and cannot be turned off with another switch.
- Condition of existing plumbing should be free from lime and iron buildup. Piping that is built up heavily with lime and/or iron should be replaced. If piping is clogged with iron, a separate iron filter unit should be installed ahead of the water softener.
- The softener should be located close to a drain.
- Always provide for the installation of a bypass valve.
- The full weight of the plumbing system must be supported by pipe hangers or other means.
- Do not install the system where it would block access to the water heater, main water shutoff, water meter, or electrical panels.
- Install the system in a place where water damage is least likely to occur if a leak develops.
- If applicable, use di-electric unions where dissimilar metals are present.

NOTICE

All plumbing connections have right-hand threads. Turn clockwise to install.

NOTICE

If O-ring lubricant is required, only use a silicone based compound formulated for potable water O-ring applications. Watts recommends Ordering Code #7300948 Silicone Lubricant. The use of other types of lubricants may attack the control's plastic or rubber components. Petroleum-based lubricants can cause swelling in rubber parts, including O-rings and seals.

⚠ WARNING

Do not exceed water pressure of 125psi (8.6 bar). Do not exceed 110°F (43°C). Do not subject unit to freezing conditions.

General Installation Instructions

1. Turn off water heater(s).
2. Turn off the main water supply to the building and open a treated water faucet (cold and hot) to relieve any pressure within the plumbing system.

NOTICE

Mineral tanks with 42" and 48" diameters include a bottom center PVC flange cover. Please make sure flange bolts are tight before proceeding with the installation.

3. Place the mineral tank(s) in the desired installation location. Make sure that the location is level and sturdy enough to support the weight of the system once it is in operation.
4. After the mineral tank(s) have been placed into their final position, and will not need to be moved again, load the mineral tanks with resin and gravel media following the instructions below:
 - 4a. Inspect the distributor screens for damage, and make sure all screens are present before loading the mineral tank with media. Before proceeding with installation, replace any damaged components immediately.

- 4b. Cap the top open end of the distributor tube with tape and plastic sheeting to keep all media and foreign debris from entering the distributor tube. This cap must be secure and not come off during media loading.
- 4c. Place the distributor tube, screen end down, into the mineral tank and center it in the bottom. The top of the distributor tube should be flush with the top of the tank. Test the tape cap to make sure it can not come off during the media loading process.
- 4d. Fill the mineral tank $\frac{1}{3}$ full with water to prevent breakage of the distributor tube screens during the media loading process.
- 4e. Make sure the plastic and tape cap is secure to the top of the distributor tube, place a funnel on the top of the tank and load first the gravel (load the largest gravel first, then the smaller gravel) then the softening resin into the tank. The cap must not come off of the distributor tube during the loading of the media.
- 4f. Remove the funnel from the top of the tank and plastic cap and tape from the top of the distributor tube. DO NOT PULL UP ON THE DISTRIBUTOR TUBE when removing the cap. The distributor tube top must remain at the proper height to the top of the tank.
- 4g. Clean any media from the control valve seating area on top of the mineral tank. Media on the O-ring sealing surface of the tank can prevent the control valve's O-ring seal from sealing properly.
- 4h. Lubricate all O-rings on the bottom of the control valve and control valve's flange base (distributor tube port O-ring and top of tank O-rings). Use nonpetroleum based silicone lubricant only.
- 4i. Press the factory supplied stainless steel upper diffuser basket, flared side up, into the top flange port of the mineral tank. The flare will seat on the inside of the tank flange when fully inserted. Then position valve flange components on top of tank flange. See page 35 for assembly diagram.
- 4j. Place the control valve on top of the tank. When performing this step, seat the top of the distributor tube inside the distributor port located on the bottom of the control valve first, then press the control valve down until the control valve come in contact with the tank flange. This ensures that the distributor tube is properly seated into the bottom of the control valve. Then place the 2 flange segments over the control valve's base and insert flange bolts. See page 35 for assembly diagram.

⚠ WARNING

The weight of this control valve exceeds 115 pounds. Do not attempt to install or remove control valve alone. Team lifting and proper scaffolding should be used. A 2" male NPT X Eye Bolt fitting has been provided with each control valve. This assembly is intended to be threaded into the control valve's drain port, tightened with a wrench, and used as a lifting point when placing control valve onto tank flange.

- 4k. Tighten flange bolts.

System Installation

- 5*. Install flow meter(s). For PWS30 Simplex and PWS30-P Progressive Series systems, apply a suitable thread sealant to the male threads of the meter(s) and with the meter's direction of flow arrow pointing in the direction of water flow, install the meter(s) directly into the outlet port(s) of the system control valve(s). For PWS30-2 Series Duplex Alternating systems, apply a suitable thread sealant and install the meter in the common outlet water line of the two control valves within 30" of the nearest control valve's controller. The meter's direction of flow arrow must point in the direction of water flow.
- 6*. Rotate meter(s) clockwise to tighten, by gripping the meter(s) on the hexagonal surface with a wrench, and continue to tighten the water meter(s) until the meter dome(s) is pointing straight up.
- 7*. Connect the cold water supply to the inlet port of the water softening system's control valve(s). When constructing the supply line, install an inlet water isolation valve and plumbing union fitting (user supplied) in the supply line of each control valve and close the isolation valve. The union fitting(s) should be located between the isolation valve and the systems inlet port.
- 8*. Install an inlet water sample port in the supply line and close it.
- 9*. If risk of vacuum exists, install Watts # 0556031 vacuum relief valve in the supply line to protect the system against vacuum damage.
- 10*. Connect the outlet water connection of the water meter(s) for PWS30 and PWS30-P systems, and to the control valve outlet water ports for PWS30-2 systems, to the water line requiring softened water. When constructing this outlet water line, install an outlet water isolation valve and plumbing union fitting (user supplied) in the outlet line of each control valve and close the isolation valve. The union fitting(s) should be located between the outlet of the control valve(s) and the outlet isolation valve(s).
- 11*. Install an outlet water sample port on the outlet water line of the system and close it.
- 12*. Install a bypass valve between the inlet and outlet plumbing water lines and close it.
- 13*. If not already factory installed on the control valve, attach the drain line flow controller directly to the control valve's drain port. See pages 12-13 for connection detail. The flow arrow on the drain line flow controller must point towards the drain receptacle. Only plumbing tape is allowed on the drain line flow controller fitting threads.

⚠ WARNING

Operating a system without a drain line flow controller will cause all media to flow out of the system through the drain line.

- 14*. Construct the drain line routing it to an appropriate drain receptacle abiding by all local building and plumbing codes. DO NOT construct drain line to elevations that exceed 4 feet above the drain port of the control valve, or reduce the drain line diameter to smaller than that of the drain line flow controller. Install a plumbing union fitting in the drain line close to the drain line flow controller. The drain line must be anchored to the floor.
- 15*. Connect the brine tank to the water softener's control valve brine port using Sch. 40 PVC pipe with a minimum pipe diameter of 1". Install the brine line flow controller(s) (BLFC) for the PWS30 and PWS30-P series systems directly to the control valve's brine connection port(s). For PWS30-2 series systems, install the BLFC on the brine tank's brine connection port. See pages 12-13 for connection detail. All BLFC direction of flow arrows must point in the direction of the brine tank. Install a plumbing union fitting in the brine line close to the BLFC. The brine tank should set on a common elevation as the mineral tank and within 10 feet of the water softener control valve. Add enough water (6") to the brine tank so that water covers the top of the air check. DO NOT add salt to the brine tank at this time.
16. Connect meter cable(s) into meter dome(s) according to Figure 1. NXT2 & SXT controller meter cable(s) must use side port on meter dome(s). Connect the other end of the meter cable(s) to the control valve's P5 port located on the control valve's controller of the control valve the meter is plumbed into. For PWS30-2 series systems, connect the meter cable to a single control valve controller. See pages 15 & 16 for P5 location.
17. Connect the 24V transformer power supply wire(s) to the P14 port(s) of the control valve controller(s). See pages 15 & 16 for P14 location.
18. If applicable, install a metal bonding strap across metal inlet and outlet plumbing lines to maintain electrical continuity.

The system is now ready for Start Up.

*See Installation Diagrams pages 12-14 of this manual for additional information.

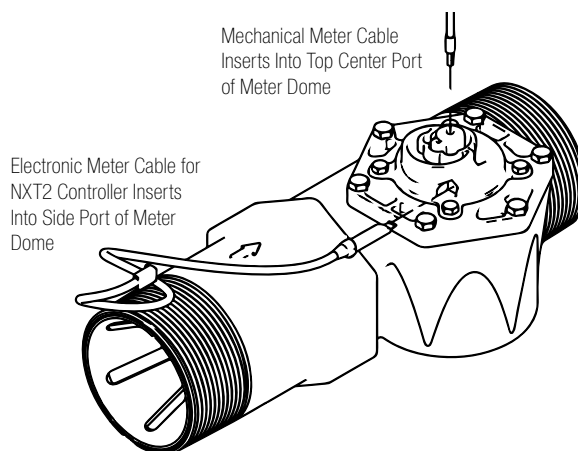

Figure 1

Start Up Instructions

1. Ensure all inlet and outlet isolation valves and the bypass valves are in the closed position and the treated water faucet hot and cold side are in the open position.
2. Open the main water supply valve to the building.
3. Check for leaks and repair as needed.
4. Plug the power cord of the control valve into an electrical outlet to energize system.
5. Locate "Manually Initiating a Regeneration" on page 19 of this manual and follow the steps to place the system into the backwash position. Once the system cycles into the backwash position, unplug the control valve from the power outlet to keep the system in the backwash position.
6. Open the inlet isolation valve slightly until water can be heard flowing through the isolation valve and allow the mineral tank to fill with water. Air will come out of the drain line until the mineral tank is full of water. Once water flow at the drain line is observed, fully open the inlet valve and allow water flow to drain for 10 minutes to flush the resin bed of any color. If water at the drain shows any discoloration, continue to flush the resin bed until water at the drain is clear.
7. After resin bed flushing is complete, plug the system back in to the power outlet so that it will return to the service position. Repeat steps 4, 5, 6 and 7 on the other tank(s) if this is a Series PWS30-2 Duplex Alternating or PWS30-P Progressive system.
8. For PWS30-P or PWS30-2 series systems, connect the factory supplied inner-connecting communication cable(s) between the P1 and P3 ports of the control valve's controllers shown on pages 15 & 16.
9. Program each control valve according to the Master Programming section beginning on page 22. See page 21 for definitions of system number types.
10. Put the appropriate amount of water in the brine tank(s). This is accomplished by manually cycling the control valve(s) to cycle step 4 "Brine Tank Refill" and allowing a complete brine tank refill cycle to conclude. This step must be done for each brine tank in the system only after the proper brine tank refill time has been programmed into each controller.
11. Put the appropriate amount of salt in each brine tank. Do Not fill the salt level past the brine well lid.
12. Fully open the outlet isolation valve(s).
13. Ensure the bypass valve is in the closed position.
14. Check for leaks and repair as needed.
15. Allow water to flow from the hot and cold side treated faucet until all air has been purged from the plumbing system. Then close both the hot and cold side treated water faucet.
16. Turn on water heaters.

Start up is now complete and the system is ready for operation.

Installation Diagrams - Series PWS30 Simplex Systems

Installation Reference Notes For All System Installation Drawings:

1. All dimensions are on page 6 of this manual & unless otherwise noted & are ± 1 inch (25mm).
2. All items shown in phantom line are to be provided by others.
3. All dimensions are subject to change without any notice.
4. Install unions fittings on inlet, outlet & drain plumbing connections.
5. Provide a 2 feet minimum clearance above mineral tank for filling media.
6. A GFCI equipt electrical outlet should be provided within 5 feet of equipment location.
7. Use dielectric unions on plumbing connections of control valve when dissimilar metals are present.
8. Provided system shall not be subject to any vacuum. If risk of vacuum is present, install siphon break on drain line & install vacuum relief valve Watts ordering code # 0556031 on inlet line.
9. Brine tank dimensions shown on table are factory selected for use with the specified system size.
10. Do not install drain line directly to a drain. For proper drain connection follow all national, state and local codes. Do not construct drain line to elevations that exceed 4 feet above the control valve's drain port.
11. The full weight of the piping and valves must be supported by pipe hangers or other means.
12. Inlet and outlet headers need to be sized according to flow rate requirements by others.
13. Power requirements: 115v/60hz 2.7 Amps per control valve unless otherwise specified.

14. Brine tank must be located within 10 feet of system control valve and on a common floor elevation with mineral tank to ensure proper brine draw operation.
15. Use a minimum of 1 inch sch 40 pvc piping for construction of brine line.
16. Limit inlet pressure to not exceed maximum published operating pressure.

Drain and Brine Connection Detail for PWS30 & PWS30-P Series

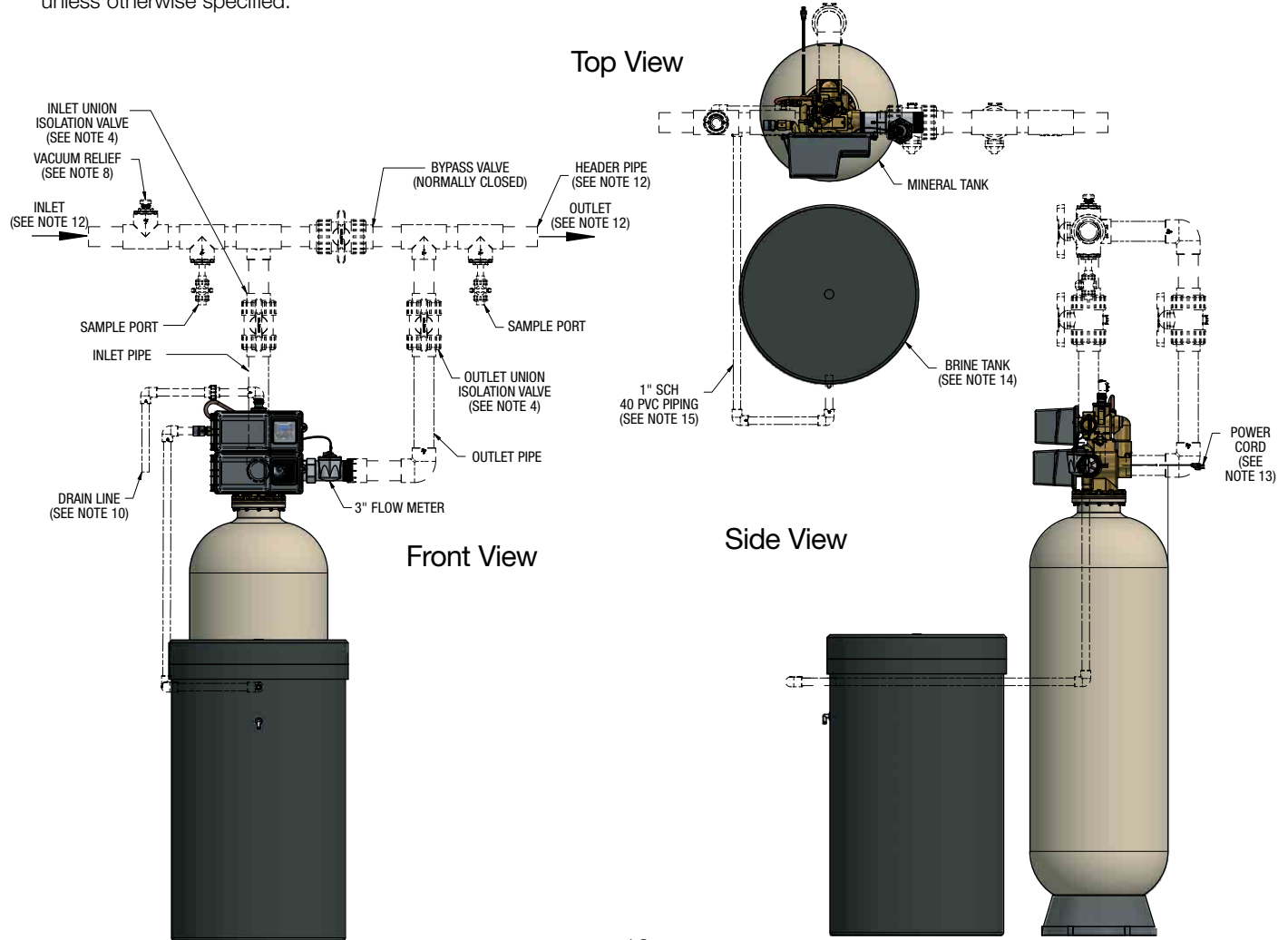
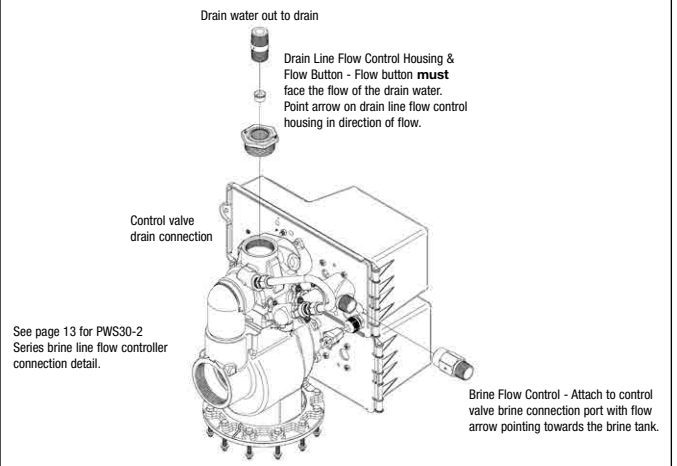

Installation Diagrams - Series PWS30-2 Duplex Alternating Systems

Side View

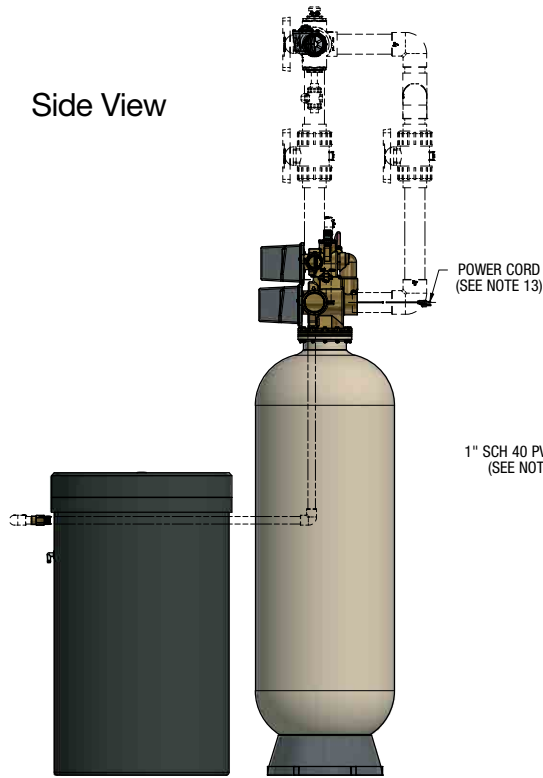

Top View

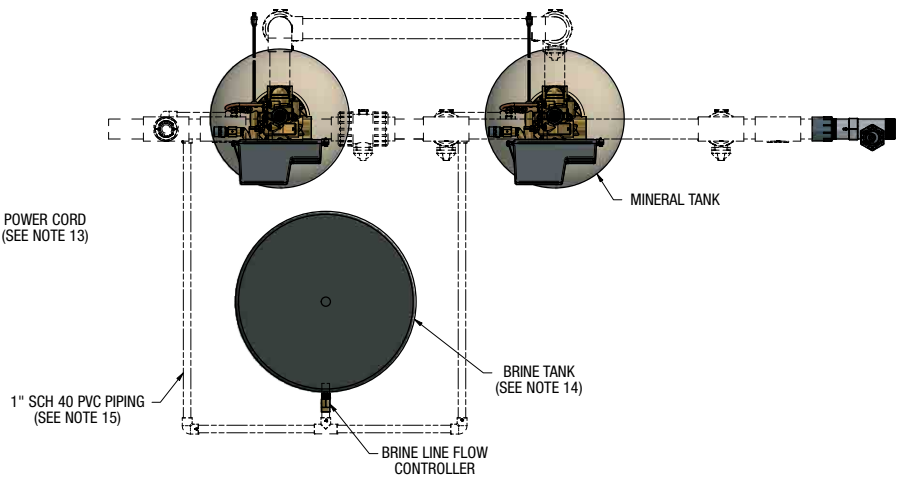

Front View

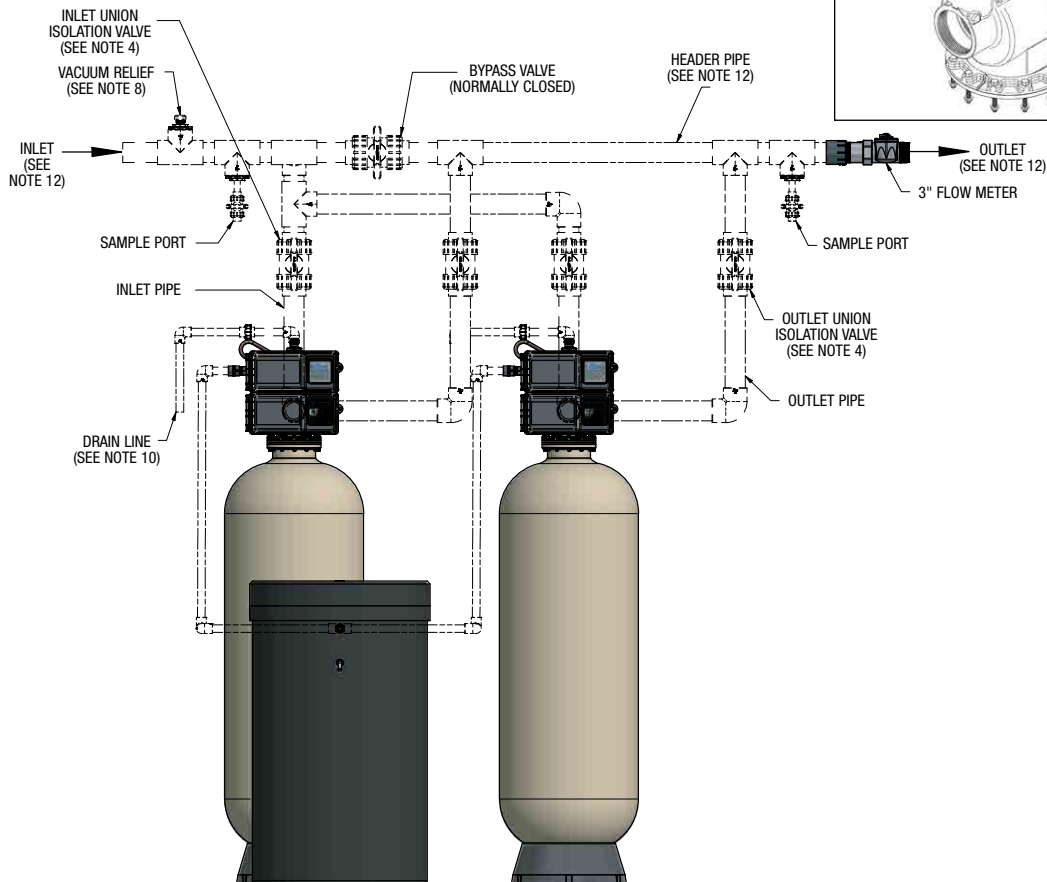

Drain and Brine Connection Detail for PWS30-2 Series

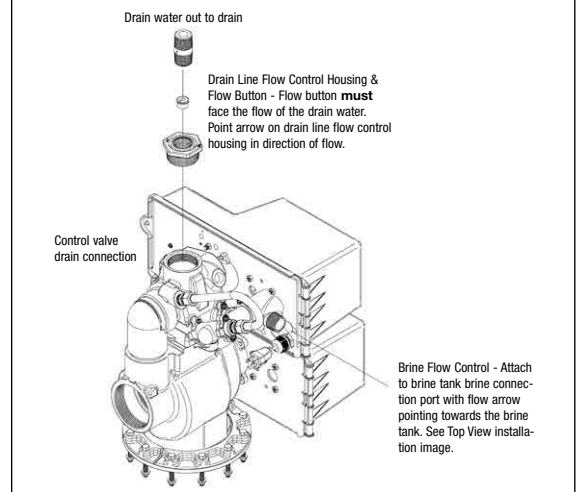

Installation Diagrams - Series PWS30-P Progressive 2-4 Tank Systems

Side View

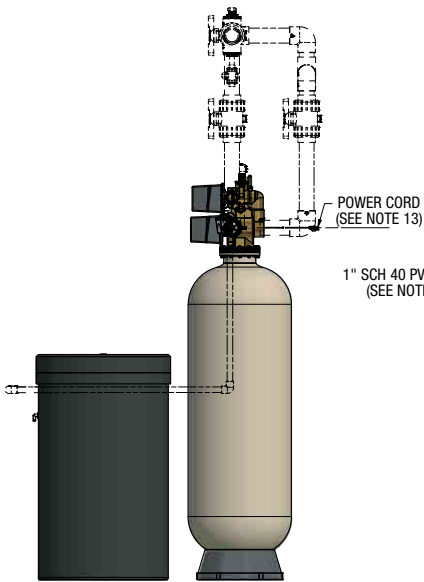

Top View

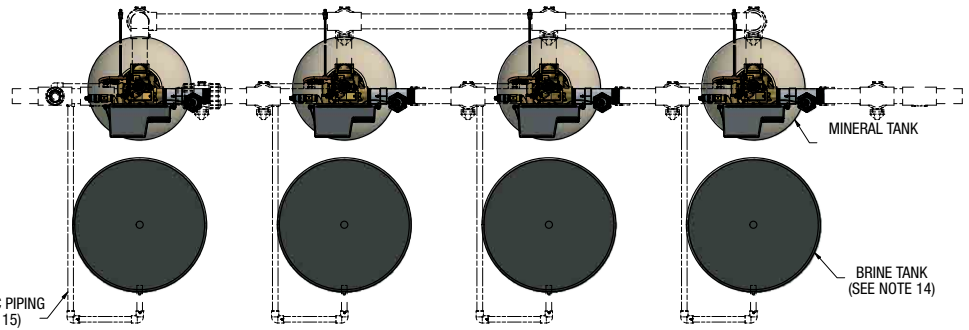

Front View

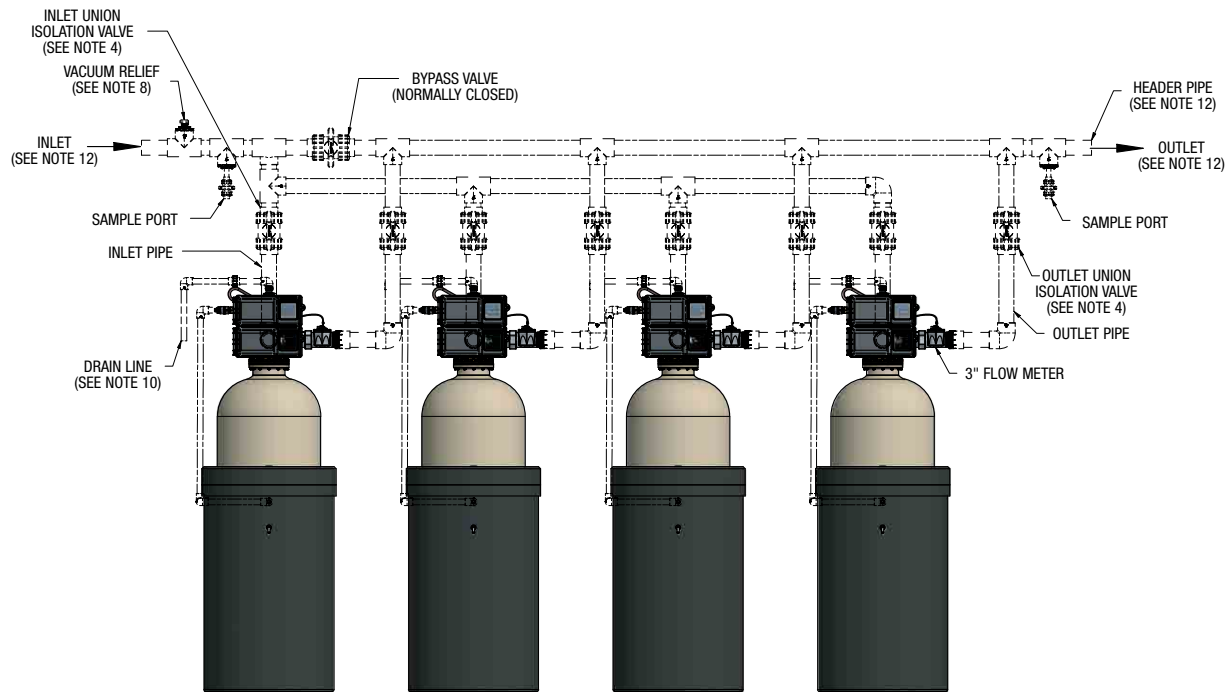

Controller Electrical Connections

Power Supply Connections

Installing the Power Supply:

Note: Power Supply includes a harness with 2 black wires that connect to circuit board, see page 16.

1. Insert black and black transformer wires into 24VDC input of control.

Network / Communication Cables and Connections

Use a shielded CAT5 Network/Communication cable.

Connect the network/communication cable first before programming.

Cable length between timers/units should not exceed 25 feet.

Connect each unit in series (do not form a loop) together from one communication port to the next communication port. It does not matter which one goes to the next one.

2510/2750/2815/2850/2900 Valves*:

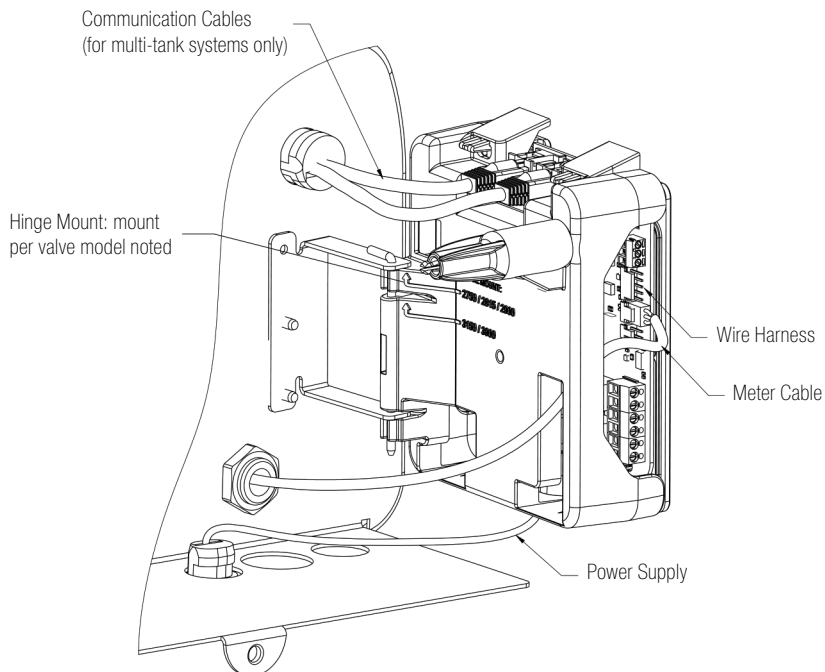

44404 Rev A

3150/3900 Valves*:

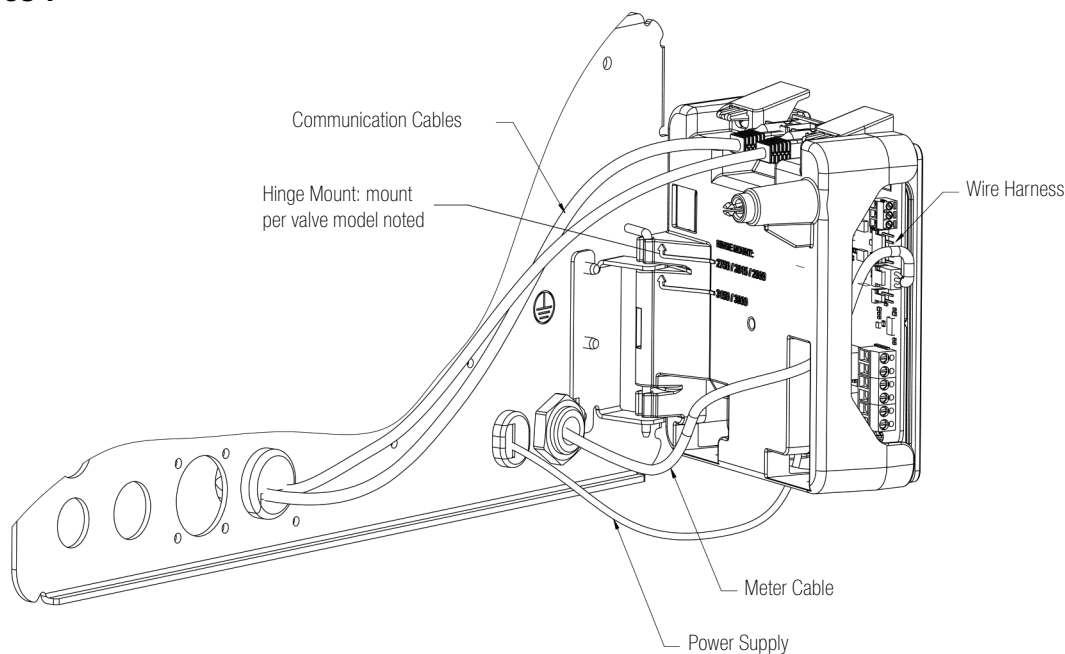

44403 Rev A

*PWS30, PWS30-2 & PWS30-P Systems use 3900 Type Control Valves.

Wiring Diagram

*Wiring diagrams are reference only. All wiring should be done by a certified electrician and meet all electrical codes.

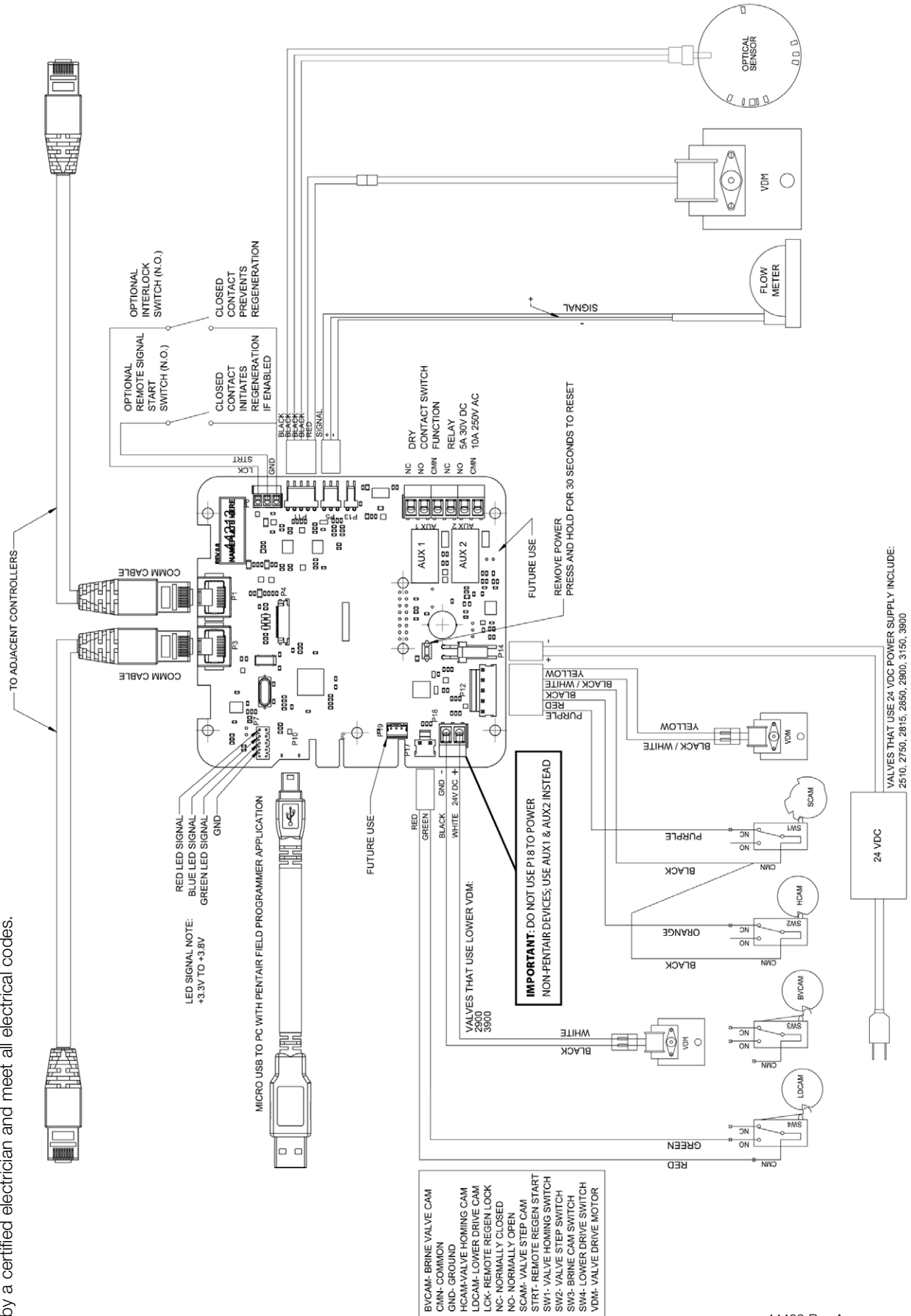

- BVCAM- BRINE VALVE CAM
- CMN- COMMON
- GND- GROUND
- HCAM-VALVE HOMING CAM
- LDCAM-LOWER DRIVE CAM
- LCK- REMOTE REGEN LOCK
- NC- NORMALLY CLOSED
- NO- NORMALLY OPEN
- SCAM- VALVE STEP CAM
- STR1- REMOTE REGEN START
- STR2- VALVE HOMING SWITCH
- SW1- VALVE STEP SWITCH
- SW2- BRINE CAM SWITCH
- SW3- LOWER DRIVE SWITCH
- SW4- VALVE DRIVE MOTOR

NXT2 Controller Programming and Operation

This system uses the NXT2 controller which is capable of operating single or multi-tank systems.

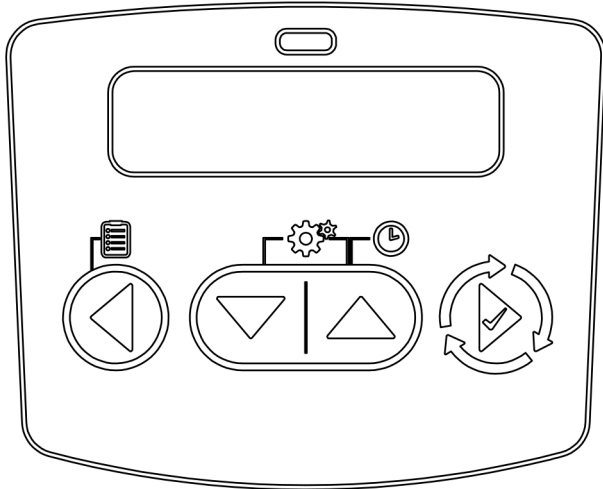

Modes of Operation

System Type	4 - Single Unit 5 - Parallel Interlock (2-8 Unit) 6 - Parallel Series Regeneration (2-8 Units) 7 - Alternating Interlock (2 Units) 8 - Alternating Delayed (2 Units) 9 - Alternating with Standby Units (2-8 Units) 14 - Progressive Demand Recall (2-8 Units)
Valve Type*	2510 2750 2815 2850 2900S 2910 (Europe only) 3150 3900
Regeneration Type	Softener/Filter Meter Delayed Softener/Filter Meter Immediate Time Clock Day of the Week Remote Regeneration
Regeneration Flow	Downflow Upflow Filter

Features

- On-screen multilingual support: English, Francais, Deutsch, Italiano, Espanol, Nederlands, Portugues
- Time of day super capacitor backup for 12-hour power loss
 - 2 to 4 line scrolling text OLED display, high contrast easy to read in low light conditions and at a distance
 - Full functional user interface with easy programming allowing forward and backwards menu navigation
 - Network two to eight valves via shielded CAT5 cables
 - LED Status Indicator
 - Blue: In Service
 - Flashing Blue: Regeneration Queued
 - Green: Regeneration
 - Flashing Green: Standby
 - Red: Error condition present
 - Two Programmable Auxiliary relay outputs
 - Time-based
 - Volume based (Chemical pump)
 - Alarm-based
 - Cycle-based
 - Standby
 - Remote input
 - Remote Lockout
 - Remote Regeneration
 - Easy installation with plug-in wiring harnesses
 - Assistance Name and Phone Number contact fields
 - Error Log History
 - Water Usage Daily (up to 13 weeks)
 - Push Settings
 - Capacitive Touch buttons
 - Two Regeneration Lockout Windows
 - Reset to factory default settings or from saveable custom settings
 - Full calendar display
 - Master Programming Lockout
 - Code-based
 - Time-based
 - Delayed
 - Icons for easy system status identification
 - Dynamic network addressing
 - Diagnostics
 - Real-time Flow Rate
 - Peak Flow Rate (can be reset)
 - Totalizer (can be reset)
 - Reserve Capacity
 - Use Since Last Regeneration
 - Last Regeneration
 - Identifiable Software Version
 - Total Number of Regenerations
 - Regeneration Interval
 - Last Settings Change
 - Error Log History
 - Average Daily Usage (per weekday, 3 month history)

*PWS30, PWS30-2 & PWS30-P Systems use 3900 Type Control Valves.

Controller Display

System Number Network Indicator Valve State Flow Indicator Status LEDs Master Indicator Time of Day

Blue LED
On - Unit in Service
Blinking - Regeneration Queued

Green LED
On - Unit in Regeneration
Blinking - Unit in Standby

Red LED
On - Error present

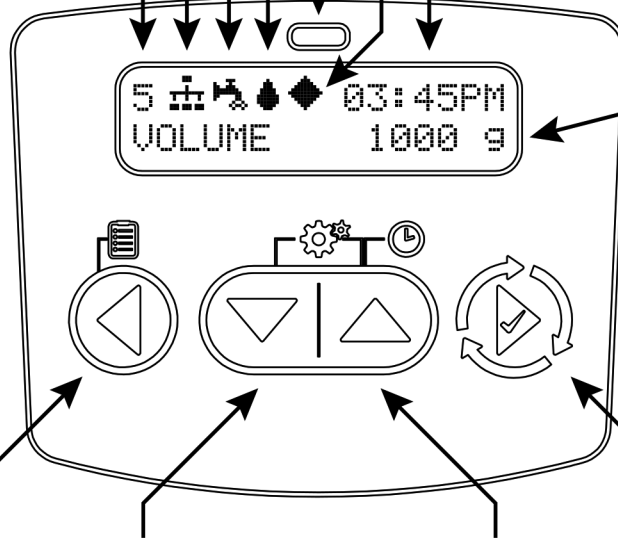

Display Screen
Alternates between Date, Flow Rate, and Volume Remaining (If a regeneration is queued, displays time until regeneration)

<p>Left Button Press: Navigate to previous menu option</p> <p>Press and Hold: Enter Diagnostic menu</p>	<p>Down Button Press: Adjust menu value down</p> <p>Press and Hold: Enter Time of Day menu</p>	<p>Up Button Press: Adjust menu value up</p> <p>Press and Hold: Enter Time of Day menu</p>	<p>Extra Cycle Button Press: Navigate to next menu option</p> <p>Press and Hold: Initiate a regeneration</p>
<p>Left Button + Down Button Press and Hold - Enter Master Programming</p>		<p> Down Button + Up Button Press and Hold - Enter User Programming</p>	

Display Icons

- | | | | |
|--|----------------------------------|--|-------------------------|
| | Valve State: Service | | Lock Window |
| | Valve State: Standby | | Initializing |
| | Flow Indicator (flashing) | | Upper Drive Movement |
| | Regeneration | | Lower Drive Movement |
| | Master Unit (auto-assigned) | | Remote Regeneration |
| | Network Indicator - Connected | | Master Programming |
| | Network Indicator - Disconnected | | User Programming |
| | Network Indicator - Unit Missing | | Diagnostics |
| | USB Connected (Field Programmer) | | Time of Day Programming |
| | Error Condition Present | | |
| | Remote Lock | | |

Controller Operation

Setting the Time of Day

Note: Set Time of Day on any unit and the rest of the units in the system will update the Time of Day automatically.

1. Press and hold the Up button for 2 seconds. The "Time" value is displayed. Press the Up or Down buttons to adjust as desired.
2. Press the Extra Cycle button to advance to the "Year" field. Press the Up or Down buttons to adjust as desired.
3. Press the Extra Cycle button to advance to the "Month" field. Press the Up or Down buttons to adjust as desired.
4. Press the Extra Cycle button to advance to the "Calendar Day" field. Press the Up or Down buttons to adjust as desired.
5. Press the Extra Cycle button to return to the normal display screen.

NOTE: Press and hold the Left button to exit without saving.

Manually Initiating a Regeneration

1. When controller is In Service or Standby, press and hold the Extra Cycle button on the main screen.
2. The controller advances to Regeneration Cycle Step #1, and begins programmed time count down.
3. Press the Extra Cycle button once to advance valve to Regeneration Cycle Step #2 (if active).
4. Press the Extra Cycle button once to advance valve to Regeneration Cycle Step #3 (if active).
5. Press the Extra Cycle button once to advance valve to Regeneration Cycle Step #4 (if active).
6. Press the Extra Cycle button once to advance valve to Regeneration Cycle Step #5 (if active).
7. Press the Extra Cycle button once more to advance the valve back to In Service.

NOTE: A manually initiated or queued regeneration can be cleared by pressing and holding the Back button. A system queued regeneration can only be cleared by stepping through a manual regeneration. If regeneration occurs for any reason prior to the delayed regeneration time, the manual regeneration request shall be cleared. Pressing the Extra Cycle button while in regeneration will cause the upper drive to advance to the next step immediately.

Controller Operation During Regeneration

In the Regeneration Cycle step display, the controller shows the current regeneration cycle name the valve is in, or has reached, and the time remaining in that step. Once all regeneration steps are complete, the controller returns to In Service and resumes normal operation.

CYCLE 1/5	
BACKWASH	00:10:00

CYCLE 2/5	
DRAW	00:60:00

CYCLE 3/5	
RAPID RINSE	00:10:00

CYCLE 4/5	
TANK REFILL	00:12:00

CYCLE 5/5	
PAUSE	00:00:00



Press the Extra Cycle button during a system queued Regeneration Cycle to immediately advance the valve to the next cycle step position and resume normal step timing.

Controller Operation During Programming

The controller enters the Program Mode in Standby or Service Mode as long as it is not in regeneration. While in the Program Mode, the controller continues to operate normally monitoring water usage. Controller programming is stored in memory permanently.

Controller Operation During A Power Failure

All program settings are stored in permanent memory. Current valve position, cycle step time elapsed, and time of day are all stored during a power failure, and will be restored when power is re-applied. Time is kept during a power failure, and time of day is adjusted upon power up (as long as power is restored within 12 hours).

NOTE: The time of day on the main display screen will flash for 5 minutes when there has been a power outage. The flashing of the time of day can be stopped by pressing any button on the display.

Flow Meter Equipped Controller

As treated water is used, the Volume Remaining display counts down from the calculated system capacity to zero. When zero is reached, a Regeneration Cycle begins if no other units are in regeneration.

Controller Features

Remote Lock

The controller does not allow the unit/system to go into Regeneration until the Regeneration Lockout Input signal to the unit is cleared. This requires a contact closure to activate the unit. The recommended gauge wire is 16 AWG with a maximum wire length run of 50 feet.

Regeneration Day Override Feature

If the Day Override option is turned on and the valve reaches the set Regeneration Day Override value, the Regeneration Cycle starts if no other unit is in Regeneration. If other units are in regeneration, it is added to a regeneration queue. This occurs regardless of the remaining volume available.

Lock Settings (access to Master Programming)

Lock Settings prevents the user from accessing Master Programming. In Master Programming, select the desired Lock Settings option (Off, Time Based, Delayed, or Enter Code).

Time Based - User must set clock to 12:01 pm to unlock

Delayed - User must press and hold the Left and Down buttons for 60 continuous seconds to unlock

Enter Code - User must input code "1201" to unlock

Capacitive Buttons

Capacitive button entry warrant different consideration than tactile button entry. Do not wear gloves. Be sure to keep your hands and the capacitive buttons free of debris, grease, or water. Buttons may become temporarily unresponsive if environmental conditions change such as sudden humidity or temperature changes. If buttons become unresponsive, wait 5 to 10 minutes for the buttons to recalibrate.

LED Status indicator

Blue - Unit in Service

Flashing Blue - Regeneration Queued

Green - Unit in Regeneration

Flashing Green - Unit in Standby

Red - Error with codes

Power Loss Backup

Time of day super capacitor backup for power loss; rated to last minimum 12 hours

Continuous Flow Detect

Alert appears when specified continuous flow rate is detected during service over a specified duration. Continuous flow rate is adjustable from 0.1 to 99999.9 GPM/LPM (accuracy of flow rate detected will vary based on capability of meter). Duration range is adjustable from 1 to 255 hours.

Remote Regeneration

Ability to trigger a regeneration via a remote input.

Regeneration Types

Softener/Filter Meter Delayed - When volume remaining reaches zero and the scheduled regeneration time is reached (default 2 a.m. softener; 12 a.m. filter), the unit will regenerate.

Softener/Filter Meter Immediate - When volume remaining reaches zero, the unit will regenerate.

Time Clock - Once volume remaining reached zero and the selected regeneration time is reached (default 2 a.m. softener; 12 a.m. filter), the unit will regenerate.

Day of the Week - Once volume remaining reaches zero and the selected Day of the Week is reached, the unit will regenerate.

Remote Regeneration - Remote Regeneration is accomplished by a 3rd party device completing a contact closure connected to the remote regeneration input connector. The 3rd party device must complete the signal duration time that was set in the duration signal time in programming to start a regeneration. You can set the remote regeneration for immediate regeneration or delayed regeneration at the set time that was programmed for regeneration time in programming.

Reset to Factory Defaults

While powering up the unit, when the Pentair Diamond logo® logo appears, press and hold the Extra Cycle button to access the Reset menu then select Reset to Factory Defaults. Press the Extra Cycle Button to confirm your selection and to advance to the service screen. Furthermore, you may select Reset to Non-Factory Defaults to save a set of unique control parameters.



Power on the unit. When Pentair logo appears, press and hold the Extra Cycle button. The Reset menu appears.

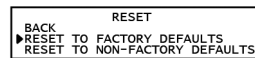

Use the up/down buttons to select.



Press the Extra Cycle button to set the desired option and return to the Service screen.



END

Lock Window

Lock Window prevents the unit from regenerating during a specified time frame. Two lock windows are available (Lock Window #1 and Lock Window #2). In Master Programming, enable a Lock Window then select the desired Lock Start time and Lock End time.

Settings Review

To prevent unintentional changes to Master Programming, enable Settings Review to view and navigate through Master Programming settings without the ability to edit.

The Pentair Diamond logo® is a trademark owned by Pentair plc or its affiliates.

Controller Features

Push Settings

The ability to transmit user settings from one unit to all other connected units. Select the desired Master Programming settings on one unit then push the same settings to all other connected units. After the push settings have completed, you may still make unique changes to individual units.

Auxiliary Relays

The NXT2 has two auxiliary relays that may be activated based on cycle, time, or volume.

AUX. 1: CYCLE BASED ...
SP BW BD RR RF SB
X X ✓ X X X

Activates during selected cycle step

AUX. 1: TIME BASED-START TIME #1 ...
1 M

Activates upon selected start time
(Range: 0-91 minutes)

AUX. 1: TIME BASED-END TIME #1 ...
5 M

Deactivates upon selected end time
(Range: Start Time plus 1 minute)

AUX. 1: VOLUME BASED - VOLUME-G ...
00100

Activates when selected volume (gallon)
is reached (Range: 0-99999)

AUX. 1: VOLUME BASED - DURATION-S ...
0010

Selected duration in seconds
(Range: 0-9999 seconds)

System 4 - Single Unit

Single Tank configuration Time Clock: No Meter Immediate:
One Meter Delayed: One Meter Remote Signal Start

System 5 (2-8 Units) Parallel Interlock)

All tanks in parallel supplying treated water. Each unit in the system will have its own flow meter/sensor input. The control will delay the start of Regeneration if another unit is already in Regeneration. Once that unit has completed a Regeneration cycle, and has returned to Service, the unit with the longest regeneration queue time will begin Regeneration. No more than one unit will be in Regeneration at a time.

System 6 (2-8 Units) Parallel Series Regeneration

All tanks in parallel supplying treated water. Only #1 control will monitor flow meter/sensor input. When a regeneration is required for the system, it will regenerate valve address #1 first, immediately followed by #2, then #3, then #4 if installed. No more than one unit will be in Regeneration at a time.

System 7 (2 Units) Alternating Immediate

One tank online supplying treated water, one tank in Standby. Only #1 control will monitor its flow meter/sensor input. Regeneration of a unit will begin after the other control has left Standby and returned to Service. When the Regeneration cycle is complete, the regenerated unit will enter Standby. Standby on each tank is controlled by the relay on the NXT2 circuit board.

System 8 (2 Units) Alternating Delayed

Immediate Transfer Delayed Regeneration One tank online supplying treated water, one tank in Standby. Only #1 control will monitor its flow meter/sensor input. Online unit depletes its volume. Once this occurs the offline unit comes online. The previously online unit goes offline and delays its regeneration until the programmed regeneration time has been reached.

System 9 (2-8 Units) Alternating with Standby Units

Up to 7 tanks online supplying treated water, one tank in Standby. Meter/sensor input is required on each tank. Regeneration of a unit will begin after the other control has left Standby and returned to Service. When the Regeneration cycle is complete, the regenerated unit will enter Standby. Standby on each tank is controlled by the relay on the NXT2 circuit board.

System 14 (2-8 Units) Progressive Demand Recall

Meter input is required on each tank. Unit #1 will begin In Service with #2, #3, and #4 (if installed) will begin in Standby. At least one unit is In Service at all times. When flow rate to the Primary Service Unit increases to a user specified rate, the next unit in sequence will move from Standby to Service. As the flow rate falls below the user specified rate, subsequent tanks will return to Standby. When the Primary Service Unit regenerates, the next unit in sequence will become the new Primary Service Unit. As each units capacity is reached, the controller will initiate a Regeneration of that unit. Depending on the number of units in the system and flow rate demand, the regenerated unit will then be placed either into Standby or Service. Only one unit will be in Regeneration at a time.

Master Programming Mode Flow Chart

CAUTION

Before entering Master Programming, please contact your local professional water dealer.

NOTICE

To identify your model softener, locate the diameter and height dimensions from the mineral tank label and check the specification charts within this manual to identify which model uses that size mineral tank.

NOTE: Depending on current option settings, some values cannot be viewed or set.

Master Programming Mode

1. Press and hold the Left and Down buttons simultaneously for 3 seconds to enter Master Programming mode.
2. To navigate, press the Extra Cycle button to advance to the next value. Press the Left button to retreat to the previous value.
3. Where applicable, use the Down and Up buttons to adjust a value as desired. When entering data into text fields (such as Assistance Name) or numerical fields (such as Hardness), press the Extra Cycle button to advance to the next character/digit and press the Left button to retreat to the previous character/digit. Proceed through all available characters/digits to advance to the next value.
4. To reset/clear a value (such as Assistance Name), while on the value, press and hold the Down and Up buttons simultaneously for 5 seconds.
5. To exit Master Programming Mode, progress through all available values or after 5 minutes of inactivity the controller will exit automatically. To exit master programming without saving changes, press the Left button until you return to the service screen.
6. Depending on the current controller programming, certain values may not be able to be viewed or set.
7. The controller will display local information, not system information.
8. In the event of a regeneration occurring while displaying master programming, the regeneration step and time remaining will be displayed. When regeneration has been completed, the display will return to the main screen.

	SETTINGS REVIEW ON OFF	Example: On: View settings without the ability to alter settings. Off: User has ability to alter settings.
	LANGUAGE PORTUGUES ENGLISH FRANCAIS	Example: English, Francais, Duetsch, Italiano, Espanol, Nederlandse, Portugues
	ASSISTANCE NAME 1 ▲	Example: 12 characters maximum.
	ASSISTANCE NAME 2 ▼	Example: 12 characters maximum.
	ASSISTANCE PHONE ▼	Example: 14 characters maximum.
	SYSTEM SYSTEM 4 SYSTEM 5 SYSTEM 6	Example: 4, 5, 6, 7, 8, 9, 14
	NUMBER OF TANKS 3 2 8	Example: 2, 3, 4, 5, 6, 7, 8
	TRIP POINT #1 - GPM 0001 ▲	Example: Trip Points only available/visible when System Type 14 is selected.
	TRIP POINT #1 - SERVICE DURATION 1 S	Example: Range: 1-90 seconds
	TRIP POINT #1 - STANDBY DURATION 60 S	Example: Range: 60-300 seconds
	VALVE 2815 2850 2900	Example: 2510, 2750, 2815, 2900, 3150, 3900: PWS30, PWS30-2 & PWS30-P Systems use 3900 Type Control Valves.
	REGEN. FLOW UPFLOW DOWNFLOW FILTER	Example: Upflow Downflow Filter
	REGEN. TYPE SOFTENER METER DEL SOFTENER METER IMM TIME CLOCK	Example: Softener Meter Delayed Softener Meter Immediate Time Clock Day of the Week
	UNITS METRIC US	Example: Metric US
	CAPACITY - GRAINS 0023828 ▲	Example: Range: 0-9,999,999 grains
	HARDNESS - GPG 025 ▲	Example: Range: 0-199 GPG
	RESERVE FIXED VOLUME WEEKLY RESERVE VARIABLE RESERVE	Example: Fixed Volume Weekly Reserve Variable Reserve Fixed %
	REMOTE REGENERATION DELAYED OFF IMMEDIATE	Example: OFF Off, Immediate, Delayed
	REMOTE SIGNAL DURATION 1 S	Example: Range: 1-9999 seconds
	DAY OVERRIDE/TIME-DRIVEN 10 D	Example: Range: Off - 99 Days
	REGEN. TIME 02:00HR	Example: Range: 0 - 23 Hours 59 Minutes

Master Programming Mode Flow Chart - Cont'd

Example:

Range: 0 - 23 Hours 59 Minutes

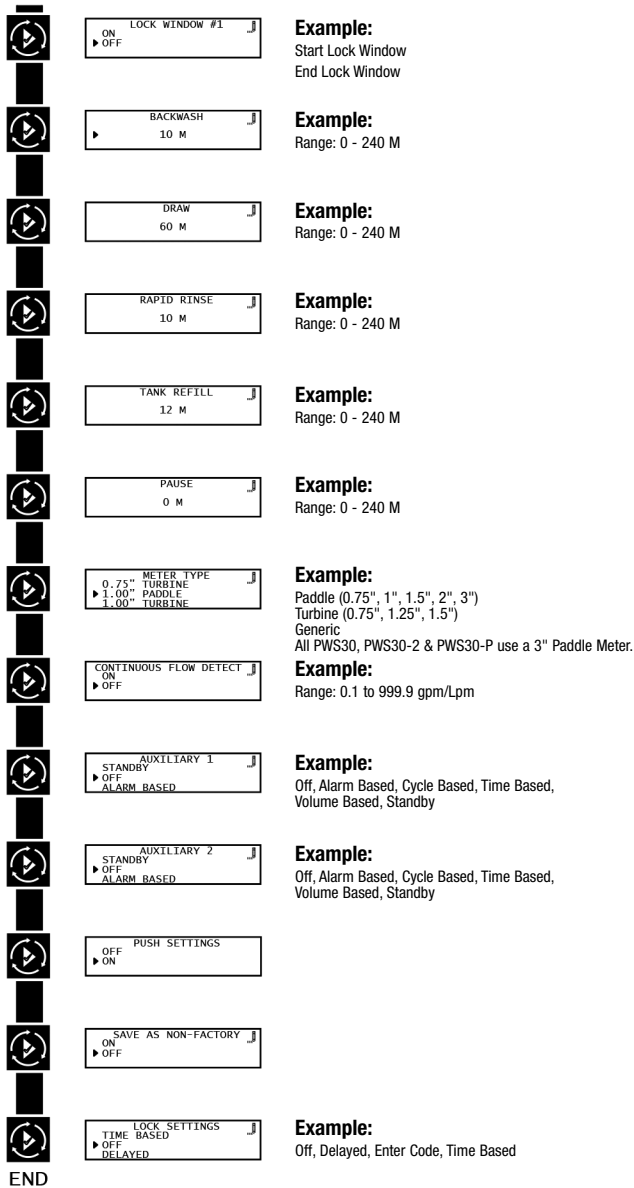

User Programming Mode Flow Chart

User Programming Mode

1. Press and hold the Down and Up buttons simultaneously for 3 seconds to enter the User Programming mode.
2. To navigate the menu, press the Extra Cycle button to advance to the next value. Press the Left button to retreat to the previous value.
3. Where applicable, use the Up and Down buttons to adjust a value as desired.
4. After progressing through all available values, the controller will return to Normal operation.
5. To exit diagnostic mode, progress through all cycles, or press & hold Left button at any time, or simply wait 5 minutes and controller will automatically return to normal operation.
- 6 Depending on the current controller settings, certain values may not be able to be viewed or set.
7. The controller will display local information, not system information.
8. In the event of a regeneration occurring while displaying user programming, the regeneration step and time remaining will be displayed. When regeneration has been completed, the display will return to the main screen.

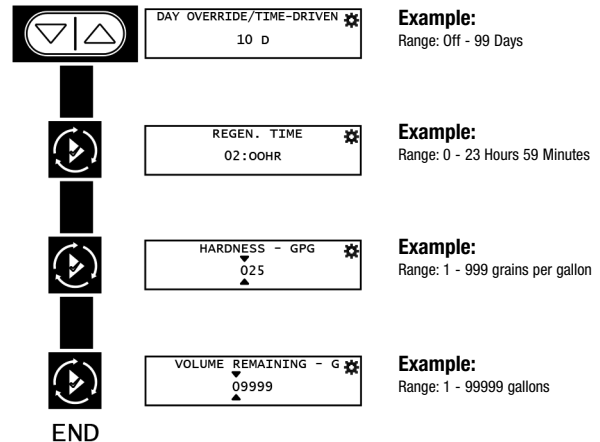

Diagnostic Programming Mode Flow Chart

Diagnostic Programming Mode

1. Press and hold the Left button to enter Diagnostic Programming mode.
2. To navigate, press the Extra Cycle button to advance to the next value. Press the Left button to retreat to the previous value.
3. Where applicable, use the Up and Down buttons to adjust a value as desired.
4. To reset/clear a value (such as Totalizer or Error Log), while on the value, press and hold the Up and Down buttons simultaneously.
5. After progressing through all available values, the controller will return to normal operation.
6. To exit diagnostic mode, press and hold the Left button at anytime or after 5 minutes of inactivity the controller will return to normal operation automatically.
7. Depending on the current controller programming, certain values may not be able to be viewed or modified.
8. The controller will display local information, not system information.
9. In the event of a regeneration occurring while displaying diagnostics, the regeneration step and time remaining will be displayed. When regeneration has been completed, the display will return to the main screen.

	FLOW RATE 29.7 GPM	Example: Real-time flow rate reading
	PEAK FLOW 30.1 GPM	Example: Peak flow since last regeneration
	TOTALIZER 482474 G	Example: Gallons at the outlet since installation
	RESERVE 1588 G	Example: Reserve Capacity setting
	USE SINCE REGEN 7331 G	Example: Gallons at the outlet since last regeneration
	LAST REGEN. 4 H	Example: Time since last regeneration
	SOFTWARE VERSION 13026	Example: Installed software version
	NO. OF REGENS 32	Example: Total number of regenerations since installation
	REGEN INTERVAL 3 D 21 H	Example: Duration between regenerations
	LAST SETTINGS CHANGE 14 H 0 M	Example: Last time programming settings were changed.

	ERROR LOG ERROR LOG EMPTY	Example: Record of error events chronologically
	SUN-AVERAGE USAGE 29.7 G	Example: Average usage from past Sunday
	SUN-DAILY USAGE 2017-10-10 0 G 2017-01-02 0 G 2017-12-26 0 G	Example: Average usage from past 3 Sundays
	MON-AVERAGE USAGE 29.7 G	Example: Average usage from past Monday
	MON-DAILY USAGE 2016-10-10 0 G 2017-01-02 0 G 2016-12-26 0 G	Example: Average usage from past 3 Mondays
	TUE-AVERAGE USAGE 29.7 G	Example: Average usage from last Tuesday
	TUE-DAILY USAGE 2016-10-10 0 G 2017-01-02 0 G 2016-12-26 0 G	Example: Average usage from past 3 Tuesdays
	WED-AVERAGE USAGE 29.7 G	Example: Average usage from last Wednesday
	WED-DAILY USAGE 2016-10-10 0 G 2017-01-02 0 G 2016-12-26 0 G	Example: Average usage from past 3 Wednesdays
	THU-AVERAGE USAGE 29.7 G	Example: Average usage from last Thursday
	THU-DAILY USAGE 2016-10-10 0 G 2017-01-02 0 G 2016-12-26 0 G	Example: Average usage from past 3 Thursdays
	FRI-AVERAGE USAGE 29.7 G	Example: Average usage from last Friday
	FRI-DAILY USAGE 2016-10-10 0 G 2017-01-02 0 G 2016-12-26 0 G	Example: Average usage from past 3 Fridays.
	SAT-AVERAGE USAGE 29.7 G	Example: Average usage from last Saturdays
	SAT-DAILY USAGE 2016-10-10 0 G 2017-01-02 0 G 2016-12-26 0 G	Example: Average usage from past 3 Saturdays

END

Time of Day Programming Mode Flow Chart

Setting the Time of Day

NOTE: Set Time of Day on any unit and the rest of the units in the system will update the Time of Day automatically.

1. Press and hold the Up button for 2 seconds. The “Time” value is displayed. Press the Up or Down buttons to adjust as desired.
2. Press the Extra Cycle button to advance to the “Year” field. Press the Up or Down buttons to adjust as desired.
3. Press the Extra Cycle button to advance to the “Month” field. Press the Up or Down buttons to adjust as desired.
4. Press the Extra Cycle button to advance to the “Calendar Day” field. Press the Up or Down buttons to adjust as desired.
5. Press the Extra Cycle button to return to the normal display screen.

NOTE: Press and hold the Left button to exit without saving.

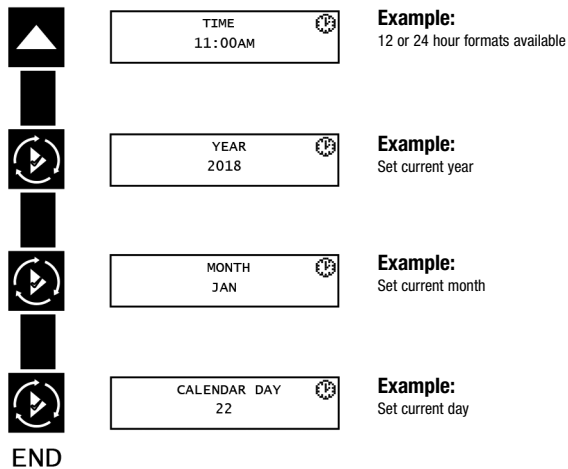

NXT2 Programming Parameters and Ranges

SYSTEM TYPE	4				5	6	7	8	9	14	PROGRAMMING PARAMETER RANGES		
	REGEN TYPE	TIME CLOCK	DAY OF THE WEEK	SOFTENER/FILTER METERED IMMEDIATE	SOFTENER/FILTER METERED DELAYED	INTERLOCK	SERIES	ALTERNATING	ALTERNATING	ALTERNATING	PROGRESSIVE DEMAND RECALL	US	METRIC
Settings Review	X	X	X	X	X	X	X	X	X	X	X	On, Off	
Language	X	X	X	X	X	X	X	X	X	X	X	English Francais Deutsch Italiano Espanol Nederlands Portugues	
Assistance Name 1, 2	X	X	X	X	X	X	X	X	X	X	X	Custom	
Assistance Phone	X	X	X	X	X	X	X	X	X	X	X	Custom	
Regen Type	X	X	X	X	X	X	X	X	X	X	X	Time Clock Day of the Week Softener/Filter Metered Immediate Softener/Filter Metered Delayed	
Valve	X	X	X	X	X	X	X	X	X	X	X	2510 2750 2815 2850 2900 3150 3900	
Regen Flow	X	X	X	X	X	X	X	X	X	X	X	Upflow, Downflow, Filter	
Units	X	X	X	X	X	X	X	X	X	X	X	US, Metric	
Remote Regeneration	X	X	X	X	X	X	X	X	X	X	X	Off, Immediate, Delayed	
Auxiliary 1, 2	X	X	X	X	X	X	X	X	X	X	X	Off, Alarm Based, Cycle Based, Time Based,	
Lock Window 1, 2	X	X	X	X	X	X	X	X	X	X	X	On, Off	
Meter Type			X	X	X	X	X	X	X	X	X	Paddle (0.75", 1", 1.5", 2", 3") Turbine (0.75", 1.25", 1.5") Generic	
Continuous Flow Detect			X	X	X	X	X	X	X	X	X	On, Off	
Save as Non Factory	X	X	X	X	X	X	X	X	X	X	X	On, Off	
Lock Settings	X	X	X	X	X	X	X	X	X	X	X	Off, Delayed, Enter Code, Time Based	
Day Override / Time Drive	X		X	X	X	X	X	X	X	X	X	Off-99 Days	
Regen Time	X	X		X		X		X				Any	
Day of the Week		X				X						SU, MO, TU, WE, TH, FR, SA	
Capacity			X	X	X	X	X	X	X	X	X	0-9,999,999 Grains	0-9,999,999 Grams, 0-560,287 Lx°DH, 0-1,000,000 Lx°FTH, 0-701,557 Lx°EH
Hardness			X	X	X	X	X	X	X	X	X	0-199 GPG	0-19,999 mg/L, 0-1,402 °EH, 0-199.9 °FTH, 0-112 °DH
International Hardness Units			X	X	X	X	X	X	X	X	X	mg/L, °EH, °FTH, °DH	
Reserve				X		X						Weekly Reserve, Variable Reserve, Fixed %, Fixed Volume	
Number of Tanks (Max)	1	1	1	1	8	8	2	2	8	8		2, 3, 4, 5, 6, 7, 8	
Push Settings					X	X	X	X	X	X	X	On, Off	
Trip Point #1-7 GPM											X	0-1,999 GPM	0-7,569 LPM
Trip Point #1-7 SD											X	1-90s	
Trip Point #1-7 STBD											X	60-300s	

Replacing the Media

NOTICE

Ion exchange resin may need to be replaced periodically due to physical breakdown caused by chlorine/chloramine disinfectants, or fouling caused by certain metals such as iron and manganese.

1. Mark the location of the mineral tanks on the floor incase they need to be moved once all water, resin and gravel has been removed. This will help with realignment of the plumbing after media replacement. DO NOT attempt to move a mineral tank that contains media and or water.
2. Open the bypass valve.
3. Close the inlet and outlet isolation valves for the mineral tank needing media replacement
4. Locate "Manually Initiating a Regeneration" on page 19 of this manual and follow the steps to place the system in the backwash position. This relieves any pressure inside the mineral tank. Once the system cycles into the backwash position, unplug the control valve from the power outlet to keep the system in the backwash position.
5. Disconnect the inlet, outlet, and drain union plumbing fittings. Then, if necessary for the removal of the control valve from the mineral tank, remove the remaining plumbing from the inlet, outlet and drain ports of the control valve.
6. Disconnect the meter cable from the from the from the meter dome and from the P5 port located on the back of the control valve controller. Store the meter cable in a safe location.
7. Disconnect the brine plumbing from the control valve's brine connection port.
8. Disconnect the power supply cable from P14 port located on the back of the control valve controller.
9. If this is a PWS30-2 or PWS30-P series system disconnect any interconnecting communication cables from the P1 and P3 ports located on the back of the control valve controllers.
10. Remove the control valve from the mineral tank by loosening and removing all flange bolt nuts. Remove flange bolts and flange segments then lift up on control valve to disconnect it from the tank flange. Store the control valve in a safe location.
11. Note the top of the distributor tube. It must be flush with the top of the tank. If it is above the top of the tank by more than ½" the distributor tube may have become disconnected from the distributor screen in the bottom of the mineral and must be reconnected.
12. Obtain a length of ¾" sch. 40 PVC that is the same height as the mineral tank and a length of 1" clear braided poly-vinyl hose. The hose must be long enough to reach the nearest floor drain. (Both of these can be acquired at a local hardware store).
13. Insert one end of the pipe inside the hose and the other end of the pipe into the top of the mineral tank and down into the resin media. Put the other end of the hose inside a water permeable bag and locate the bag over the floor drain.
14. Insert a garden hose into the bag side of the poly-vinyl hose to fill the hose and PVC pipe with water. Air will bubble out of the tank. Once all the air is out of the hose and pipe, remove the garden hose from the polyvinyl hose to establish a siphon. The resin can then be siphoned into the bag. Use the garden hose to maintain a full water level in the mineral tank to. The bag end of the poly-vinyl hose must remain lower in elevation then the end of the PVC pipe in the mineral tank to maintain the siphon. The bag will retain the resin while the water flows down the drain. Use caution not to allow resin to enter the floor drain.
15. Continue to siphon resin until it is completely evacuated from the mineral tank. Gravel will clogged the siphon hose and, if it must be removed due to fouling, or to repair or replace a damaged distributor tube and screen, must be evacuated by other means.
16. If replacing gravel, inspect lower distributor screens for damage and replace if necessary.
17. To add new media and reconnect control valve to mineral tank follow General Installation steps 3-4K located on page 9 of this manual.
18. Reconnect inlet, outlet, and drain plumbing to the control valve and tighten the plumbing union fittings on each of these plumbing lines.
19. Reconnect brine tubing to brine connection port of control valve.
20. Reconnect meter cable to meter dome. Then reconnect the other end of the meter cable to the P5 port located on the back of the control valve controller.
21. If this is a PWS30-2 or PWS30-P series system reconnect any interconnecting communication cables to the P1 and P3 ports located on the back of the control valve controllers.

⚠ WARNING

The weight of this control valve exceeds 115 pounds. Do not attempt to install or remove control valve alone. Team lifting and proper scaffolding should be used. A 2" male NPT X Eye Bolt fitting has been provided with each control valve. This assembly is intended to be threaded into the control valve's drain port (½ turn past fully hand tight) and used as a lifting point when removing control valve from tank flange.

Replacing the Media - Cont'd

22. Open the inlet isolation valve slightly, until water can be heard flowing through the isolation valve and allow the mineral tank to fill with water. Air will come out of the drain line until the mineral tank is full of water. Once water flow at the drain line is observed, fully open the inlet valve and allow water flow to drain for 10 minutes to flush the resin bed of any color. If water at the drain shows any discoloration, continue to flush the resin bed until water at the drain is clear.
23. After resin bed flushing is complete, reconnect the power supply cable to the P14 port located on the back of the control valve controller. Plug the system back in to the power outlet so that it will return to the service position.
24. Fully open inlet and outlet isolation valves and close bypass valve.
25. Check for leaks and repair as required.
26. Open hot and cold side of a treated water faucet to flush any air from the plumbing system.

If this is a PWS30-2 or PWS30-P series system replace media in each mineral tank according to this media replacement procedure.

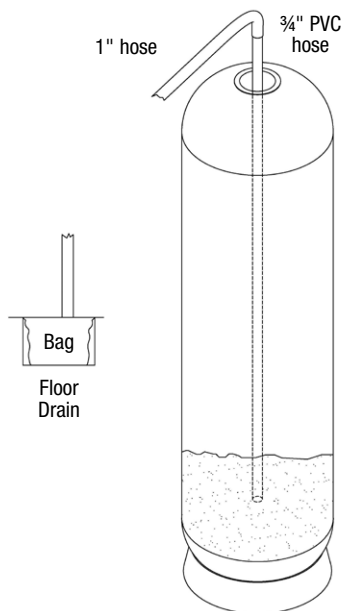

Replacement Parts - Major System Components

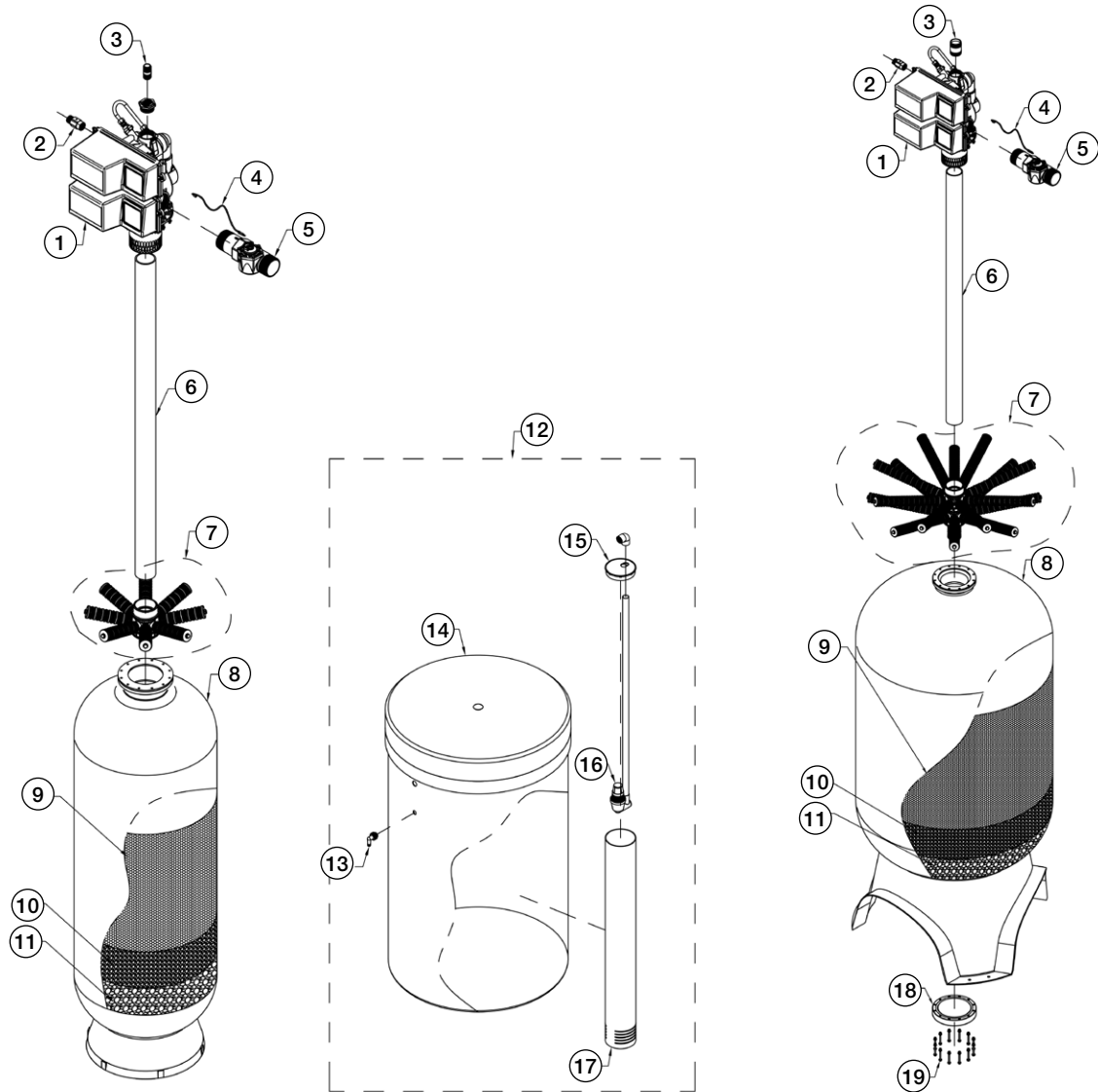

MAJOR SYSTEM COMPONENTS

ITEM NO.	QTY	ORDERING CODES	DESCRIPTION
1	1	68103969	K4041-NTH VALVE 3900/1800 120V HWBP FOR SIMPLEX MODELS
1	1	68103966	K4041-NT VALVE 3900/1800 120V NHWP FOR ALTERNATING & PROGRESSIVE MODELS
2	1	68104692	K4560710-2.0 BRINE FLOW CONTROLLER ASSEMBLY 2.0 GPM 1" MXF F/24" SOFTENER
2	1	68104693	K4560710-5.0 BRINE FLOW CONTROLLER ASSEMBLY 5.0 GPM 1" MXF F/30" & 36" SOFTENERS
2	1	68104690	K4560710-10 BRINE FLOW CONTROLLER ASSEMBLY 10 GPM 1" MXF F/42" SOFTENER
2	1	68104691	K4560710-15 BRINE FLOW CONTROLLER ASSEMBLY 15 GPM 1" MXF F/48" SOFTENER
3	1	68108485	V2003-A-15 DRAIN FLOW CONTROL 15 GPM PVC 1" MXM F/24" SOFTENER
3	1	68108500	V2005-A-25 DRAIN FLOW CONTROL 25 GPM PVC 1.5" MXM F/30" SOFTENER
3	1	68108502	V2005-A-35 DRAIN FLOW CONTROL 35 GPM PVC 1.5" MXM F/36" SOFTENER
3	1	68108508	V2006-50 DRAIN FLOW CONTROL 50 GPM PVC 2" MXM F/42" SOFTENER
3	1	68108510	V2006-60 DRAIN FLOW CONTROL 60 GPM PVC 2" MXM F/48" SOFTENER
4	1	68104399	K4519791-02 ELECTRONIC METER CABLE 25'
5	1	68104758	K4561935-10 METER ASSEMBLY 3" ELECTRONIC/MECHANICAL
6	7 FT	68103375	I7313 PIPE PVC SCH 40 3"
7	1	68101113	D2100 HUB & LATERAL S08- 8 TM DIST ASSEMBLY W/8- 8.25." LATERALS F/24" SOFTENER
7	1	68101114	D2102 HUB & LATERAL S08- 8 TM DIST ASSEMBLY W/8- 12" LATERALS F/30" SOFTENER

Continued on next page

Replacement Parts - Major System Components - Cont'd

Continued from previous page

MAJOR SYSTEM COMPONENTS			
ITEM NO.	QTY	ORDERING CODES	DESCRIPTION
7	1	68101115	D2104 HUB & LATERAL S08- 8 TM DIST ASSEMBLY W/8- 14.25" LATERALS F/36" SOFTENER
7	1	68101117	D2106D HUB & LATERAL S08 TM DIST ASSEMBLY W/16- 16.75" LATERALS F/42" & 48" SOFTENERS
8	1	68100700	C1036 FIBERGLASS MINERAL TANK 24X72 ALMOND W/ 6" TOP FLANGE
8	1	68100703	C1037 FIBERGLASS MINERAL TANK 30X72 ALMOND W/ 6" TOP FLANGE
8	1	68100706	C1038 FIBERGLASS MINERAL TANK 36X72 ALMOND W/ 6" TOP FLANGE
8	1	68100711	C1039 FIBERGLASS MINERAL TANK 42X72 ALMOND W/ 6" TOP & BOTTOM FLANGE
8	1	68100712	C1040 FIBERGLASS MINERAL TANK 48X72 ALMOND W/ 6" TOP & BOTTOM FLANGE
9	*	7300100	A4000 SOFTENING RESIN MEDIA WATTS BRAND HIGH CAPACITY SAC NA FORM
10	*	68100354	A7005A MEDIA GRAVEL #20 FLINT .06"X.125"
11	*	7300102	A7006A MEDIA GRAVEL .25"X.125"
12	1	68102512	G2009A BRINE TANK ASSY 30X50 BLK W/900 AIR CHECK
12	1	68102509	G2008C BRINE TANK ASSY 39X48 BLK W/900 AIR CHECK
12	1	68102554	G3015-1 BRINE TANK ASSY 39X60 BLK W/900 AIR CHECK
12	1	68102556	G3020A BRINE TANK ASSY 42X60 BLK W/900 AIR CHECK
12	1	68102558	G3025A BRINE TANK ASSY 50X60 BLK W/900 AIR CHECK
13	1	68102593	H1018 BRINE OVERFLOW SET
14	1	68102511	G2009 BRINE TANK 30X50 BLK EMPTY
14	1	68102507	G2008 BRINE TANK 39X48 BLK EMPTY
14	1	68102553	G3015 BRINE TANK 39X60 BLK EMPTY
14	1	68102555	G3020 BRINE TANK 42X60 BLK EMPTY
14	1	68102557	G3025 BRINE TANK 50X60 BLK EMPTY
15	1	68102592	H1017 BRINE WELL CAP 5"
16	1	68110335	K4560009-KIT AIR CHECK 900
17	1	68102606	H1071 BRINE WELL 5"X60" SLOTTED
18	1	68106636	Q7010 TANK CLOSURE 6" PVC W/O-RING F/48
19	1	68101188	D3341 BOLT SET FOR Q9058 TANK ADAPTOR INCLUDES 12 BOLTS
NOT SHOWN	1	7300787	K4541692 CAT5 COMMUNICATION CABLE F/PWS30-2 & PWS30-P

Replacement Parts - 3900 Upper Powerhead

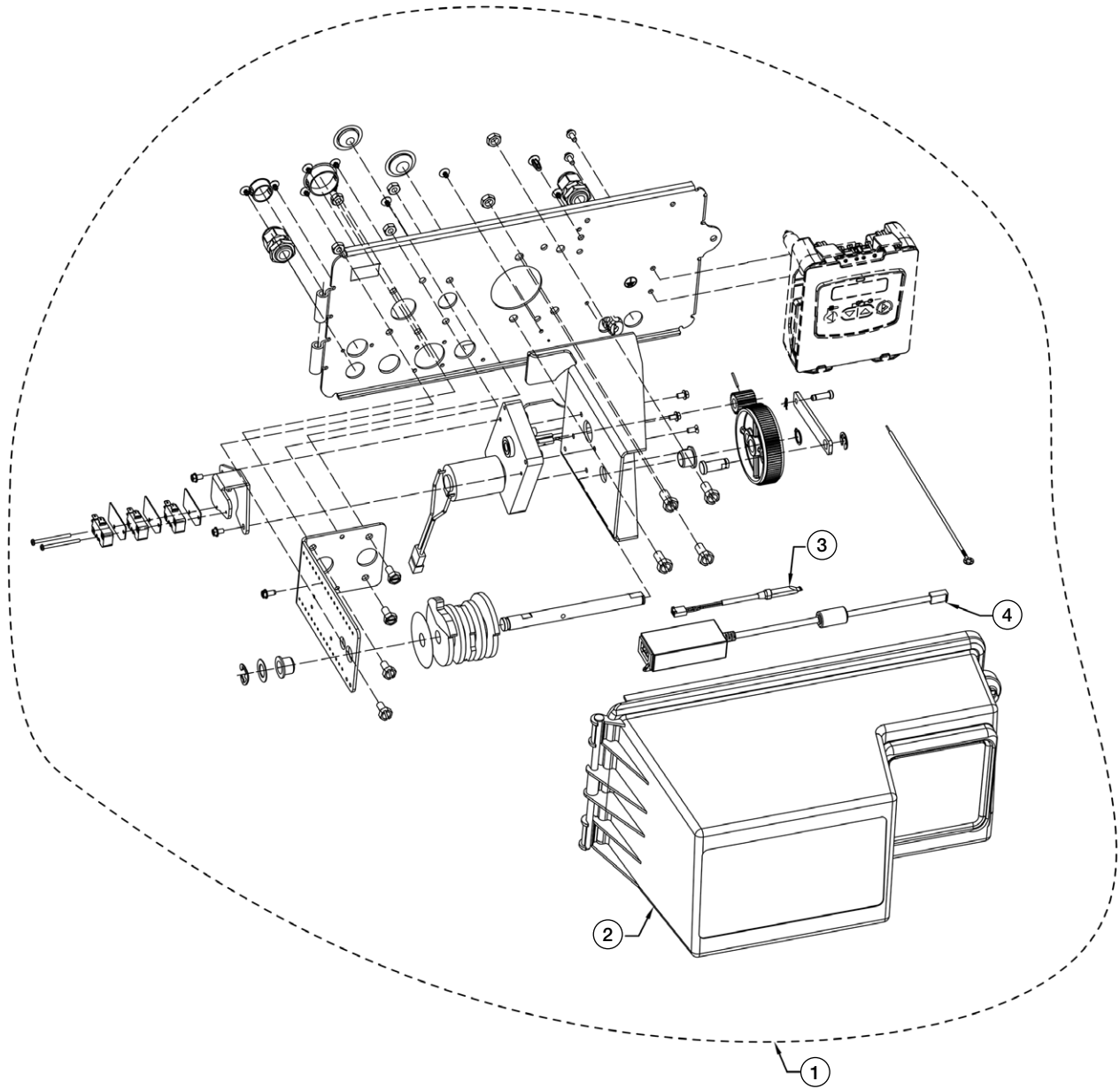

3900 UPPER POWERHEAD			
ITEM NO.	QTY	PART NUMBER	DESCRIPTION
1	1	68104640	K4560416-NT UPPER POWERHEAD F/ 3900 24V NTXT2 W/POWER SUPPLY F/120V USA WO/COVER
2	1	68104580	K4560240 COVER F/3150 & 3900 UPPER POWERHEAD
3	1	68104399	K4519791-02 ELECTRONIC METER CABLE 25'
4	1	68104471	K4544164 POWER SUPPLY CABLE 120V/24VDC F/NXT2

NXT2 Controller Assembly

1

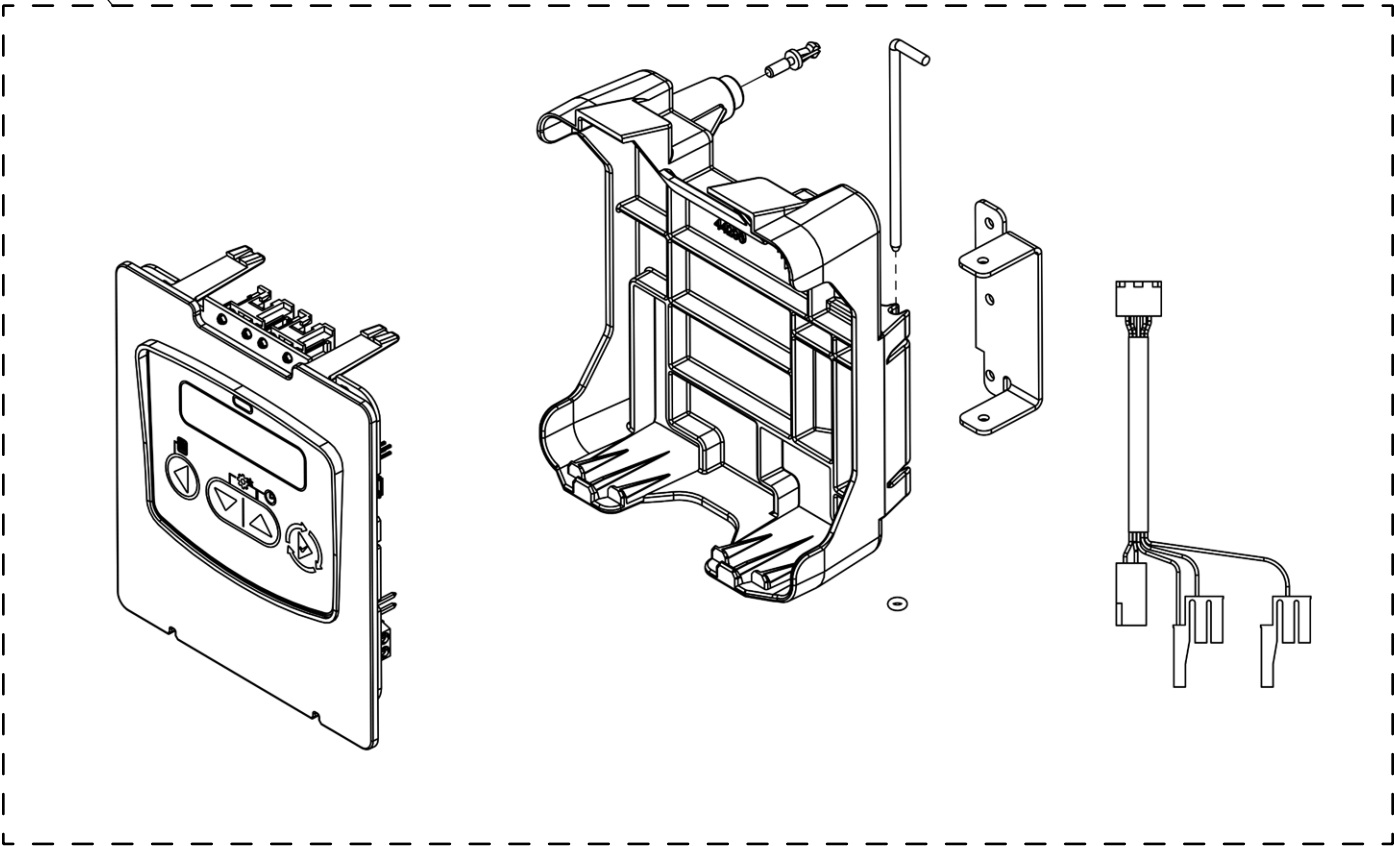

62115 Rev A

NXT2 CONTROLLER ASSEMBLY			
ITEM NO.	QTY	PART NUMBER	DESCRIPTION
1	1	68104777	K4562115 CONTROLLER ASSEMBLY NXT2

NXT to NXT2 Conversion Kit

1

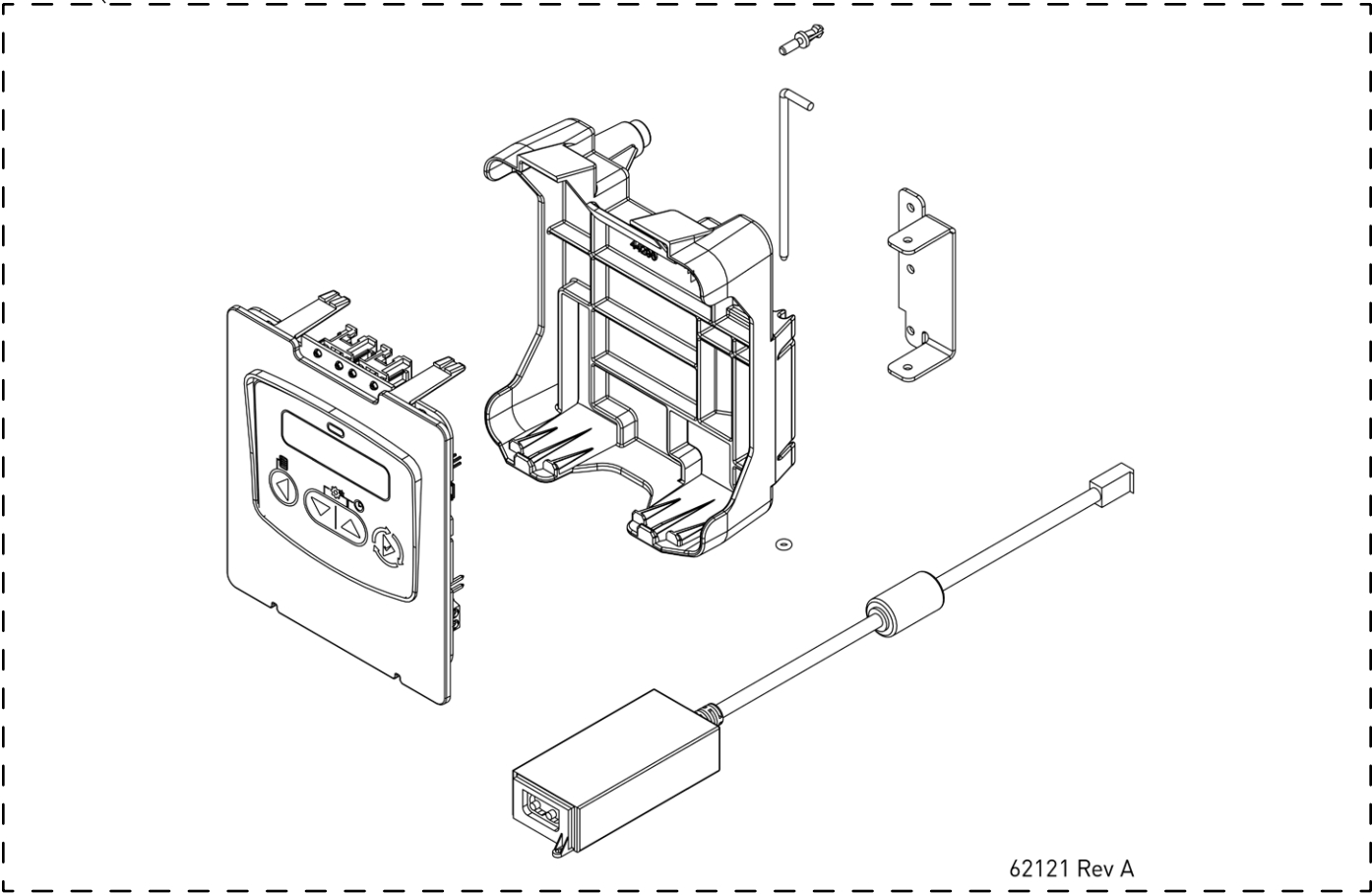

62121 Rev A

NXT TO NXT2 CONVERSION KIT			
ITEM NO.	QTY	PART NUMBER	DESCRIPTION
1	1	68104778	K4562121-01 CONTROLLER ASSY CONV KIT NXT TO NXT2 W/ POWER SUPPLY FOR USA

Replacement Parts - 3900 Lower Powerhead

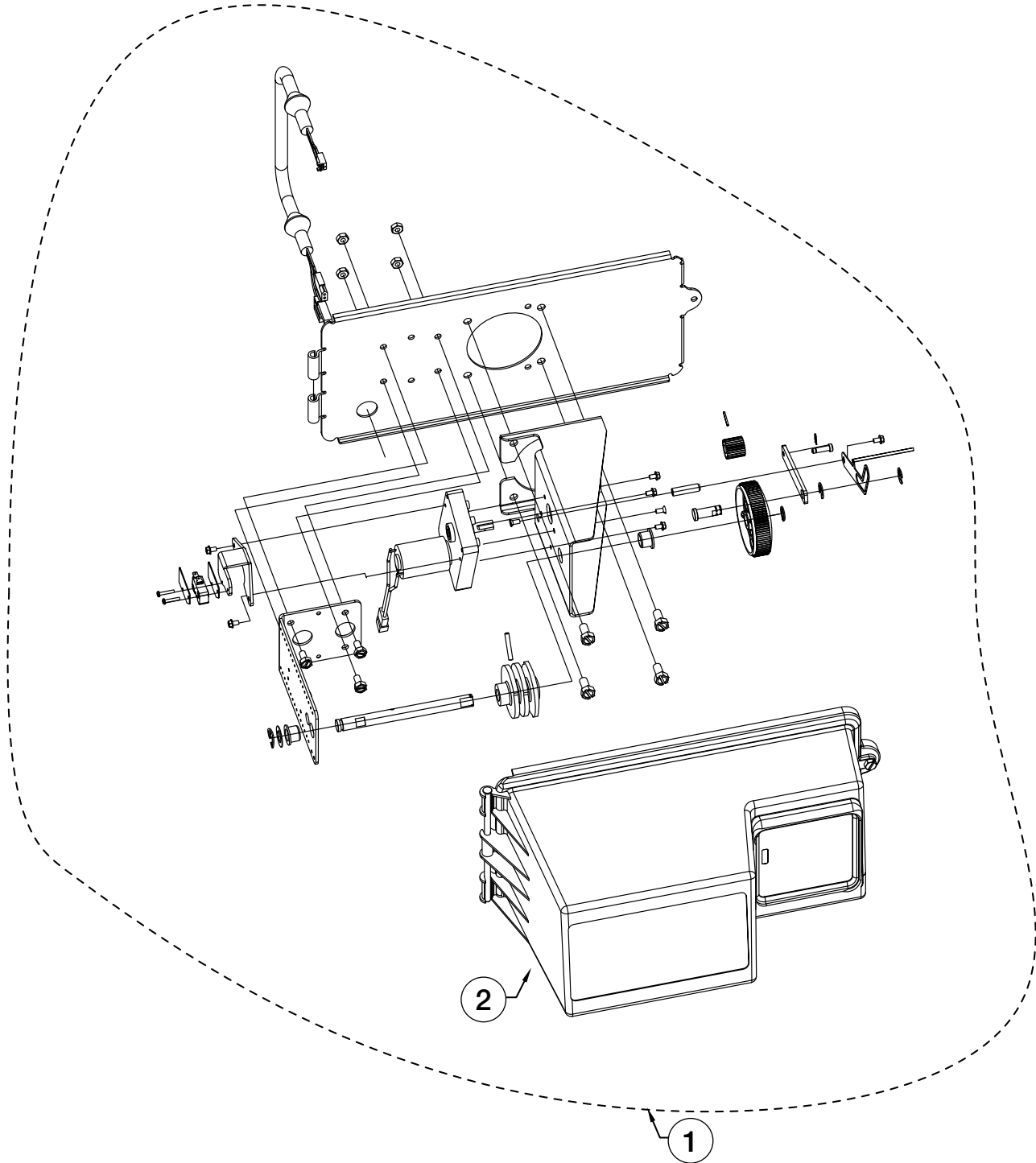

3900 LOWER POWERHEAD			
ITEM NO.	QTY	PART NUMBER	DESCRIPTION
1	1	68104642	K4560058-03 LOWER POWERHEAD F/ 3900 24V NTXT2 WO/ COVER
2	1	68104581	K4560240-22 COVER F/3900 LOWER POWERHEAD

Replacement Parts - 3900 Control Valve Body

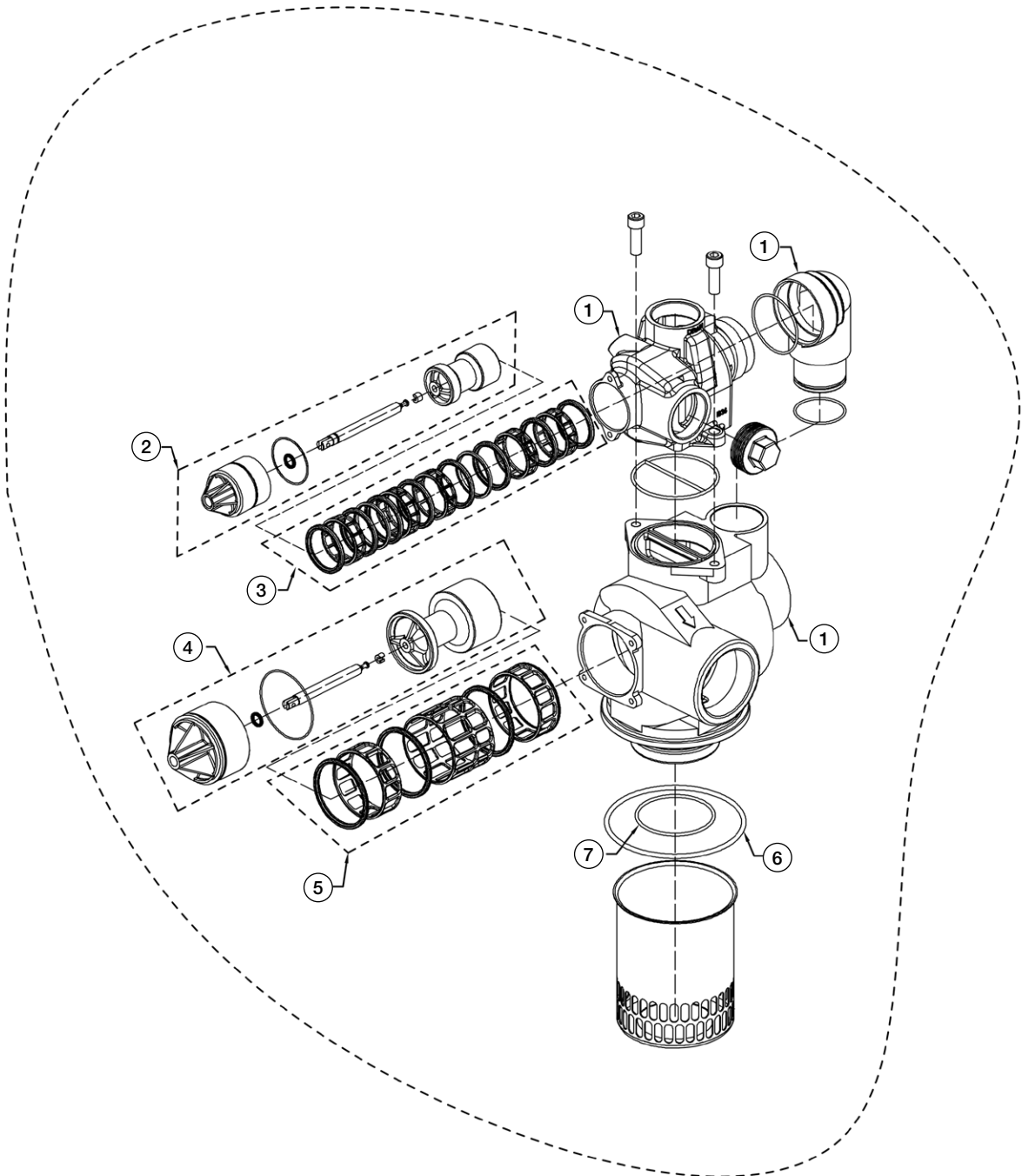

3900 DOWNFLOW CONTROL VALVE BODY ASSEMBLY			
ITEM NO.	QTY	ORDERING CODES	DESCRIPTION
1	1	-	VALVE BODY 3900 MACHINED, NPT U.S. TAP
2	1	7300799	K4560102-00 PISTON ASSEMBLY DOWNFLOW F/3150 & 3900 UPPER
3	1	7300800	K4560131 SEAL & SPACER KIT F/3150 & 3900 UPPER
4	1	7300801	K4560107-00 PISTON ASSEMBLY DOWNFLOW HWBP F/ 3900 LOWER
4	1	7300802	K4560107-10 PISTON ASSEMBLY DOWNFLOW NHWBP F/ 3900 LOWER
5	1	7300803	K4560132 SEAL & SPACER KIT F/ 3900 LOWER
6	1	68104308	K4516345 ORING #362 TANK TO VALVE F/3900
7	1	68104333	K4516800 ORING #238 F/3900 DISTRIBUTOR PILOT

Replacement Parts - 1800 Brine Valve

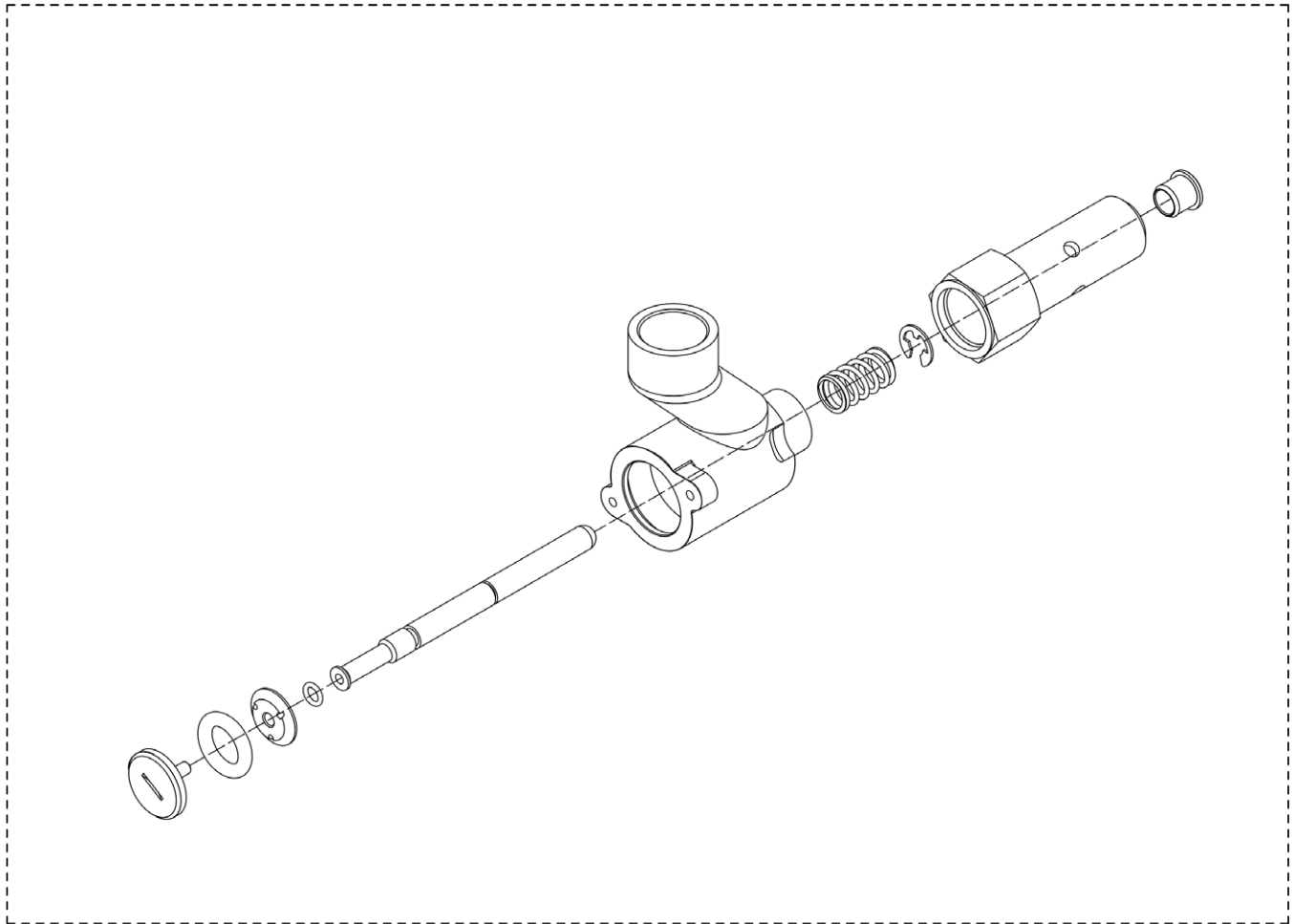

1

1800 BRINE VALVE ASSEMBLY			
ITEM NO.	QTY	PART NUMBER	DESCRIPTION
1	1	68104501	K4560036-02 BRINE VALVE ASSEMBLY 1800 BRASS DESIGN #3
1	1	68104582	K4560276-01 BRINE VALVE ASSEMBLY 1800 BRASS RETROFIT KIT TO UPDATE TO DESIGN #3

Replacement Parts - 1800 Injector Assembly

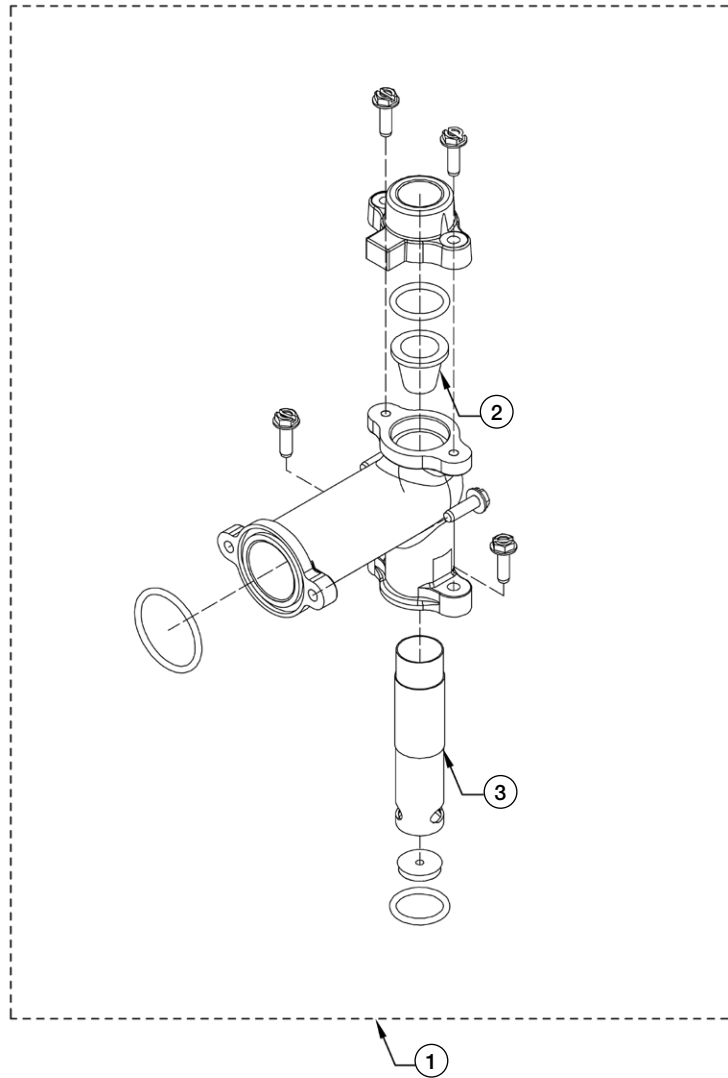

1800 INJECTOR ASSEMBLY			
ITEM NO.	QTY	PART NUMBER	DESCRIPTION
*1	1	68104583	K4560277-05 INJECTOR ASSEMBLY 1800 W/#5 INJECTOR
*1	1	68104584	K4560277-07 INJECTOR ASSEMBLY 1800 W/#7 INJECTOR
*1	1	68104585	K4560277-08 INJECTOR ASSEMBLY 1800 W/#8 INJECTOR
2	1	68104244	K4515128-04 INJECTOR NOZZLE 1800 #4 GREEN
2	1	68104245	K4515128-05 INJECTOR NOZZLE 1800 #5 RED
2	1	68104246	K4515128-06 INJECTOR NOZZLE 1800 #6 WHITE
2	1	68104247	K4515128-07 INJECTOR NOZZLE 1800 #7 BLUE
2	1	68104248	K4515128-08 INJECTOR NOZZLE 1800 #8 YELLOW
2	1	68104249	K4515128-09 INJECTOR NOZZLE 1800 #9 VIOLET
2	1	68104250	K4515128-10 INJECTOR NOZZLE 1800 #10 BLACK
3	1	68104237	K4515127-04 INJECTOR THROAT 1800 #4 GREEN
3	1	68104238	K4515127-05 INJECTOR THROAT 1800 #5 RED
3	1	68104239	K4515127-06 INJECTOR THROAT 1800 #6 WHITE
3	1	68104240	K4515127-07 INJECTOR THROAT 1800 #7 BLUE
3	1	68104241	K4515127-08 INJECTOR THROAT 1800 #8 YELLOW
3	1	68104242	K4515127-09 INJECTOR THROAT 1800 #9 VIOLET
3	1	68104243	K4515127-10 INJECTOR THROAT 1800 #10 BLACK

* 68104583, 68104584 & 68104585 INJECTOR ASSEMBLY COME WITH INJECTOR NOZZLE & THROATS LISTED IN THE DESCRIPTION. PLEASE SPECIFY TO ONE OF OUR SPECIALIST IF YOU REQUIRE A DIFFERENT INJECTOR NOZZLE & THROAT.

Replacement Parts - 3" Stainless Steel Mech/Electronic Meter

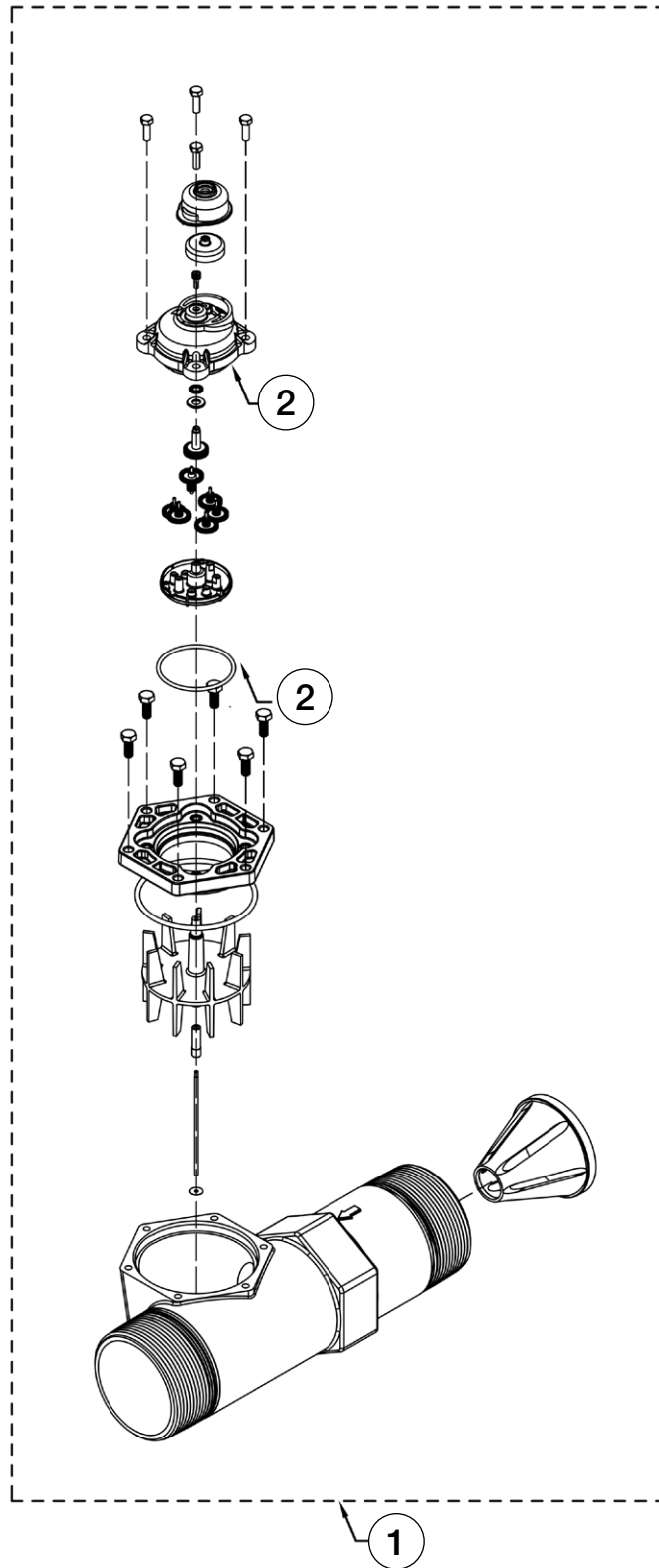

3 INCH STAINLESS STEEL METER ASSY			
ITEM NO.	QTY	PART NUMBER	DESCRIPTION
1	1	68104758	K4561935-10 METER ASSEMBLY 3" STAINLESS STEEL ELECTRONIC/MECHANICAL
2	1	68110068	K4561939 METER DOME MECH/ELEC STANDARD RANGE FOR .75"-3" METER W/ O-RING

Troubleshooting

Problem	Cause	Correction
Water conditioner fails to regenerate	Electrical service to unit has been interrupted	Assure permanent electrical service (check circuit breaker, GFCI, fuse, plug, pull chain, or switch)
	Controller is defective	Replace controller
	Power failure	Reset time of day
Softener delivers hard water	By-pass valve is open	Close by-pass valve
	No salt is in brine tank	Add salt to brine tank and maintain salt level above water level
	Injector screen plugged	Clean injector screen
	Insufficient water flowing into brine tank	Check brine tank fill time and clean brine line flow control if plugged
	Hot water tank hardness	Repeated flushings of the hot water tank is required
	Leak at distributor tube	Make sure distributor tube is not cracked. Check O-ring and tube pilot
	Internal valve leak	Replace seals and spacers and/or piston
	Reserve capacity has been exceeded	Check salt dosage requirements and adjust program to provide additional reserve
Unit used too much salt	Meter is not measuring flow	Clean meter of foreign debris. Replace meter dome
	Improper salt setting	Check salt usage and salt setting
Loss of water pressure	Excessive water in brine tank	See- Problem "Excessive water in brine tank"
	Iron buildup in line to water conditioner	Clean line to water conditioner
	Iron buildup in water conditioner	Clean control and add mineral cleaner to mineral bed. Increase frequency of regeneration
Loss of mineral through drain line	Inlet of control plugged due to foreign material broken loose from pipes by recent work done on plumbing system	Remove piston and clean control valve
	Air in water system	Assure that well system has proper air eliminator control. Check for dry well condition
Iron in conditioned water	Improperly sized drain line flow control	Check for proper drain rate
	Fouled mineral bed	Check backwash, brine draw, and brine tank fill. Increase frequency of regeneration. Increase backwash time.
Excessive water in brine tank	Plugged drain line flow control	Clean flow control
	Plugged injector system	Clean injector and screen
	Controller not cycling	Replace controller
	Foreign material in brine valve	Replace brine valve seat and clean valve
	Foreign material in brine line flow control	Clean brine line flow control
Softener fails to draw brine	Drain line flow control is plugged	Clean drain line flow control
	Injector is plugged	Clean injector
	Injector screen plugged	Clean screen
	Line pressure is too low	Increase line pressure to 20psi
	Internal control leak	Change seals, spacers, and piston assembly
	Service adapter did not cycle	Check drive motor and switches
Control cycles continuously	Misadjusted, broken, or shorted switch	Determine if switch or controller is faulty and replace it, or replace complete power head
Resin and gravel in outlet water	Damaged lower distributor screen	Replace distributor screen
High service flow rate pressure drop	Resin damaged by chlorine/chloramine	Replace resin
	Foreign material in distributor screen	Replace all media and distributor screens

Troubleshooting

Error Codes and Troubleshooting

Detected Errors

If a communication error is detected, an Error Screen will appear.

- All units In Service remain in the In Service position.
- All units in Standby go to In Service.
- Any unit in Regeneration when the error occurs completes Regeneration and goes to In Service.
- No units are allowed to start a Regeneration Cycle while the error condition exists, unless they are manually forced into Regeneration.
- When an error is corrected and the error no longer displays (it may take several seconds for all of the units in a system to stop displaying the error message), the system returns to normal operation.

NOTE: During the error condition, the control continues to monitor the flow meter and update the volume remaining. Once the error condition is corrected, all units return to the operating status they were in prior to the error. Regeneration queue is rebuilt according to the normal system operation. Or, if more than one unit has been queued for regeneration, then the queue is rebuilt according to which one communicates first.

Message Displayed	Causes for Error	Correction
Error Valve Count Mismatch	Number of NXT2 detected does not match selected system type in Master Programming	Push correct valve settings in Master Settings
Motor Stall No Changes Detected in the Optical Sensor for 6 Seconds	The motor is on but no encoder pulses are detected within a given duration while homing	Check the P11 connection and trigger a manual regeneration
Motor Run-On No CAM Switch Change Detected	The motor is on but no encoder pulses are detected or CAM Switches change state within a given duration	Verify correct valve type is chosen. Trigger a manual regeneration
Optical Sensor Undesired change detected by the Optical Sensor	The motor is off but additional encoder pulses are detected	Trigger a manual regeneration
Over-Current Motor Over-Current is Detected	Motor current exceeds thresholds	Trigger a manual regeneration
Flow Meter Error Continuous Flow Detected	Flow exceeded specified threshold for a specific duration	Trigger a manual regeneration
Error Send/Receive Failure	During a setting push, a packet was missing	Reconnect communication cables and push setting in Master Settings
Error System Type Mismatch on Network	The system type among connected units does not match	Push correct system settings in Master Settings
Microcontroller Error	Calibration or manufacturing test was not performed	Contact your Watts representative
100 Days Without Regen	100 Days have expired without a regeneration	Trigger a manual regeneration

Water Softener Flow Diagrams - Down Flow Brining

1 Service Position

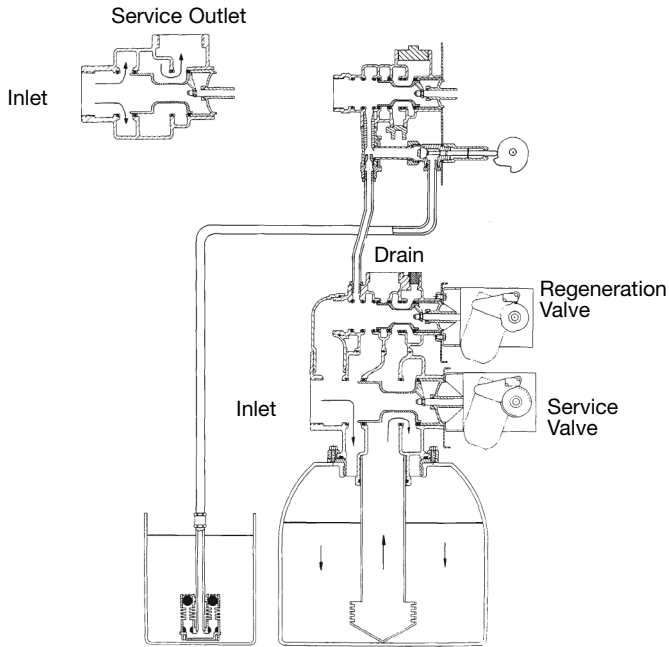

Hard water enters at valve inlet and flows down thru mineral to the bottom distributor. Conditioned water flows up thru the distributor tube, around the piston and out the outlet.

3 Brine Position

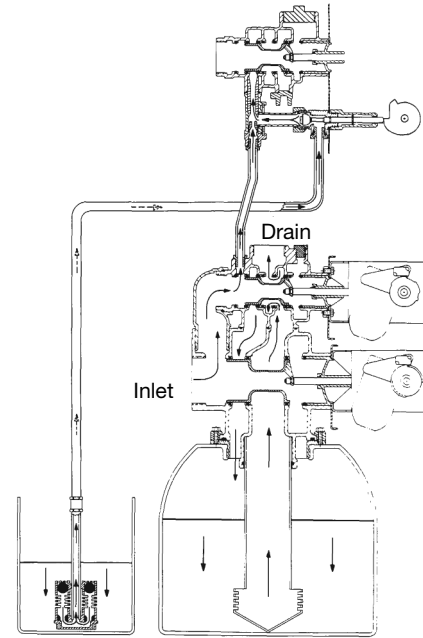

Hard water enters at valve inlet – flows thru injector nozzle and throat to draw brine from the brine tank. Brine flows down thru the mineral – into the bottom distributor – up the distributor tube – around the piston and out the drain.

2 Backwash Position

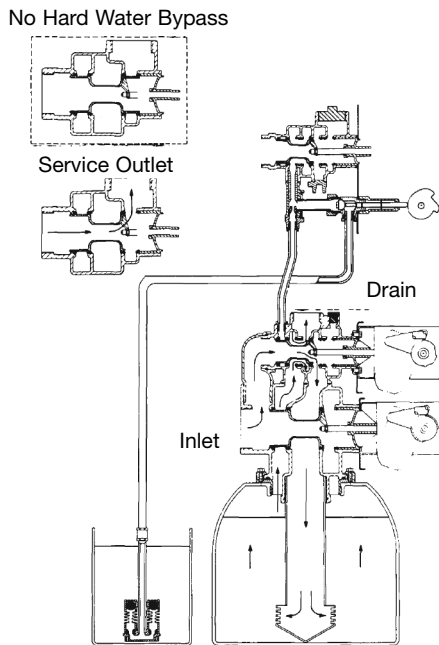

Hard water enters at valve inlet – flows thru service adapter piston for by-pass, and up thru regeneration valve inlet. Flow continues thru the regeneration valve piston – down the distributor tube – thru the bottom distributor and up thru the mineral – around the piston and out the drain. If optional no hard water by-pass piston is used, water flow to service outlet is prevented by an extension on the service outlet until the end of the rapid rinse cycle or brine tank refill cycle, depending on options chosen.

4 Slow Rinse Position

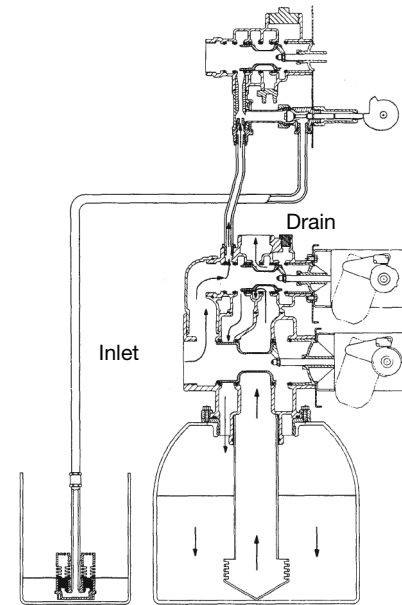

Hard water enters at valve inlet – flows thru injector nozzle and throat – down thru the mineral – into the bottom distributor – up the distributor tube – around the piston and out the drain.

Water Softener Flow Diagrams - Down Flow Brining

5 Rapid Rinse Position

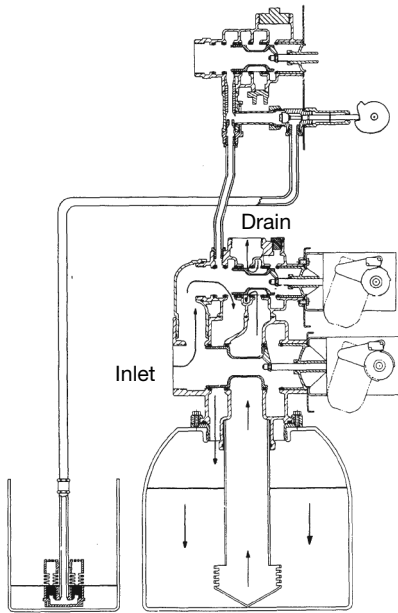

Hard water enters at valve inlet – flows thru the regeneration valve directly down thru the mineral – into the bottom distributor – up the distributor tube – around the piston and out the drain.

6 Brine Tank Refill Position

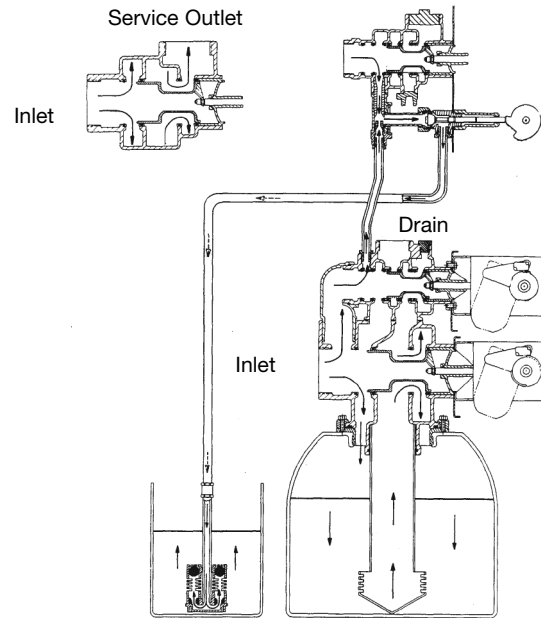

Hard water enters at valve inlet – flows thru nozzle and thru throat to brine valve to refill the brine tank. Inlet flow also continues down thru mineral to the bottom distributor. Conditioned water flows up thru the distributor tube, around the piston and out the outlet. Note: An option is available to keep service valve in by-pass position until the end of brine tank refill cycle.

Flow Data and Injector Draw Rates - Down Flow

3900 Valve & 3" Dist. Tube on 24" Tank

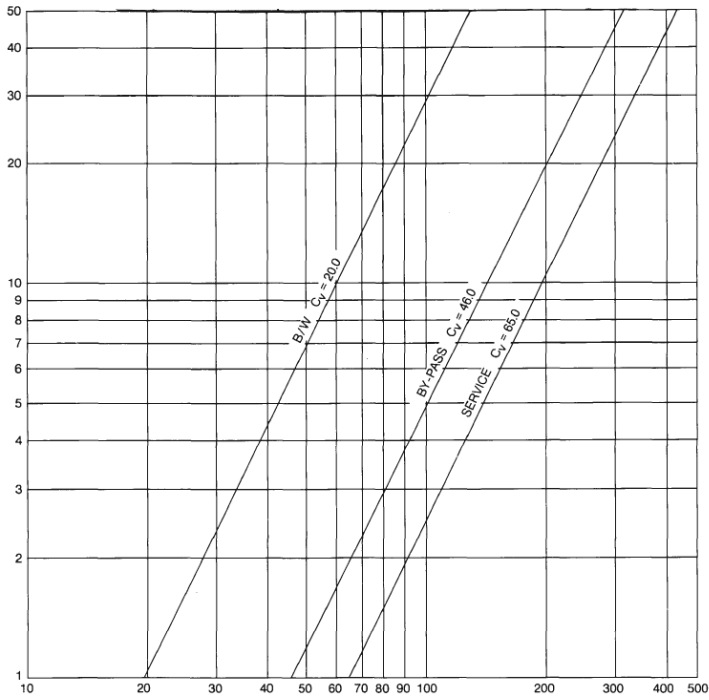

3900 on Empty Tank

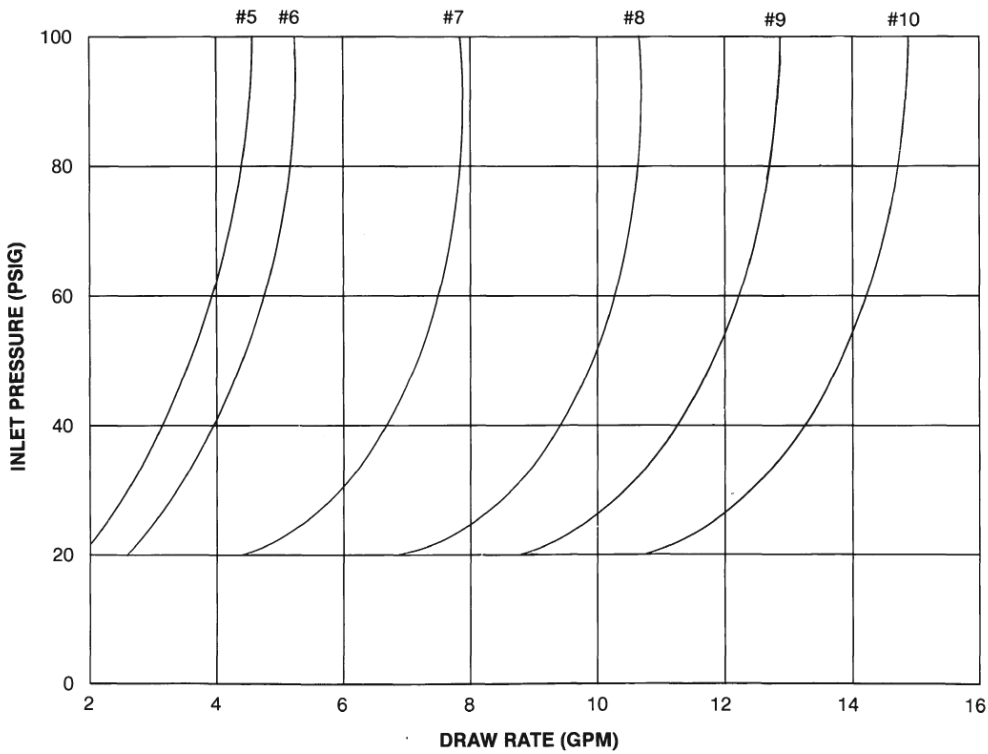

Injector Nozzle and Throat Chart for 1800 Brine Systems

1800 Brine System

Standard

Size	Color
#4	Green
#5	Red
#6	White
#7	Blue
#8	Yellow
#9	Violet
#10	Black

WATER SOFTENERS/FILTERS Limited Warranty:

The Company warrants each fiberglass tank 13 inches in diameter and smaller to be free from defects in material and workmanship under normal usage for a period of ten years from the date of original shipment.

The Company warrants each fiberglass tank 14 inches in diameter and larger to be free from defects in material and workmanship under normal usage for a period of five years from the date of original shipment.

The Company warrants any size Salt Tank (Brine Tank) to be free from defects in material and workmanship under normal usage for a period of five years from the date of original shipment.

The Company warrants each Control valve to be free from defects in material and workmanship under normal usage for a period of five years from the date of original shipment.

The Company warrants diaphragm valve nests and related controls to be free from defects in material and workmanship under normal usage for a period of one year from the date of original shipment.

The Company warrants all other components to be free from defects in material and workmanship under normal usage for a period of one year from the date of original shipment.

Water softener resins subjected to iron, manganese and chlorine levels greater than 1ppm are expressly not covered by this warranty. Manganese greensand media and expendable media such as activated carbon, Filox[®], Micro-Z[®] and neutralizing media are also not covered by this warranty. In the event of a covered defect within the warranty period, the Company will, at its option, replace or recondition the product without charge.

Disclaimer of Warranty. THE WARRANTY SET FORTH HEREIN IS GIVEN EXPRESSLY AND IS THE ONLY WARRANTY GIVEN BY THE COMPANY WITH RESPECT TO THE PRODUCT. THE COMPANY MAKES NO OTHER WARRANTIES, EXPRESS OR IMPLIED. THE COMPANY HEREBY SPECIFICALLY DISCLAIMS ALL OTHER WARRANTIES, EXPRESS OR IMPLIED, INCLUDING BUT NOT LIMITED TO THE IMPLIED WARRANTIES OF MERCHANTABILITY AND FITNESS FOR A PARTICULAR PURPOSE.

Limitation of Liability. The remedy described in the first paragraph of this warranty shall constitute the sole and exclusive remedy for breach of warranty, and the Company shall not be responsible for any incidental, special or consequential damages, including without limitation, lost profits or the cost of repairing or replacing other property which is damaged if this product does not work properly, other costs resulting from labor charges, delays, vandalism, negligence, fouling caused by foreign material, damage from adverse water conditions, chemical, or any other circumstances over which the Company has no control. This warranty shall be invalidated by any abuse, misuse, misapplication, improper installation or improper maintenance or alteration of the product

Some States do not allow limitations on how long an implied warranty lasts, and some States do not allow the exclusion or limitation of incidental or consequential damages. Therefore the above limitations may not apply to you. This Limited Warranty gives you specific legal rights, and you may have other rights that vary from State to State. You should consult applicable state laws to determine your rights. **SO FAR AS IS CONSISTENT WITH APPLICABLE STATE LAW, ANY IMPLIED WARRANTIES THAT MAY NOT BE DISCLAIMED, INCLUDING THE IMPLIED WARRANTIES OF MERCHANTABILITY AND FITNESS FOR A PARTICULAR PURPOSE, ARE LIMITED IN DURATION TO ONE YEAR FROM THE DATE OF ORIGINAL SHIPMENT.**



Watts Regulator Co.
815 Chestnut Street
North Andover, MA 01845-6098

USA: T: (800) 224-1299 • F: (978) 794-1848 • Watts.com/PureWater

Canada: T: (888) 208-8927 • F: (905) 481-2316 • Watts.ca/PureWater

Latin America: T: (52) 55-4122-0138 • Watts.com/PureWater