



Snow Melting

Replaces: New

Introduction

The Snow Melting Control 680 is designed to operate electric or hydronic equipment to melt snow or ice from any surface including driveways, walkways, business entrances, parking ramps, loading docks, hospital entrances, helipads and car wash bays. It communicates with Building Automation Systems using BACnet® or Modbus® for alert notification, remote monitoring and adjustment capability. The 680 uses a tekmar Snow/Ice Sensor 090 or a Snow Sensor 095 to automatically detect snow or ice on the snow melting slab. Up to two snow/ice sensors can be installed, thereby increasing detection area and providing backup redundancy in the case of sensor failure. Upon detection of snow or ice, the 680 operates electric heating cable, a single hydronic condensing or non-condensing boiler, or a steam valve to provide heat to the snow melt load. The 680 provides boiler return protection by operating a mixing valve or variable speed injection mixing. Monitoring of energy consumption is possible when it is connected to an optional flow sensor.

Features

- BACnet or Modbus communication
- Automatic snow/ice detection
- Supports both in-slab and retrofit aerial sensors
- Tandem snow/ice detection
- Energy monitoring
- Idling
- Storm
- EconoMelt
- Warm weather shut down
- Cold weather cut off
- Slab protection
- Exercising



Table of Contents

Important Safety Information.....	3	Sequence of Operation	35
Installation	4	Snow Melting Overview.....	35
Preparation	4	Melt Operation	35
Packaging Contents	4	Melt – Automatic Start and Stop	35
Physical Dimensions	4	Melt – EconoMelt.....	36
Installation Location.....	4	Additional Melting Time.....	36
Installing the Enclosure	5	Melt – Automatic Start and Timed Stop	36
Servicing the Control.....	5	Tandem Snow/Ice Detection	37
Rough-In Wiring.....	6	Melt – Manual Start and Timed Stop	37
Sensor Wiring	7	Idle Operation	38
Communication Wiring	10	Storm Operation	38
Control Wiring.....	11	Slab Temperature Control	38
Testing the Sensor Wiring	14	Slab Protection	39
Testing the Control Wiring	14	Warm Weather Shut Down.....	39
Manual Override – Maximum Heat	15	Cold Weather Cut Off.....	39
Manual Override – Purge	15	Snow Melt Zones and Priority	39
Manual Override – Test.....	15	Application Modes.....	40
Manual Override – Off.....	15	Electric Operation.....	40
Switch Settings.....	16	Pulse Width Modulation Zone Operation	40
Access Levels and Access Level Lock.....	16	Boiler Operation	41
User Interface.....	17	Mixing Operation	42
Home Screen.....	17	Boiler and Mixing Operation.....	42
System Operation.....	17	Outdoor Sensor	42
Symbols.....	18	Exercising	42
Help Screen.....	18	Post Purge	42
Status Menu Navigation	18	Troubleshooting.....	43
Slab Status Screen.....	19	Error Messages (1 of 4)	43
System Status Menu (1 of 2)	20	Error Messages (2 of 4)	44
System Status Menu (2 of 2)	21	Error Messages (3 of 4)	45
Settings Menu Navigation	22	Error Messages (4 of 4)	46
Setpoints Menu.....	23	Frequently Asked Questions	47
Setup – System Setup Menu (1 of 2)	24	Technical Data.....	48
Setup – System Setup Menu (2 of 2)	25	Limited Warranty and Product Return Procedure.....	48
Setup – Boiler Setup Menu (1 of 2)	26		
Setup – Boiler Setup Menu (2 of 2)	27		
Setup – Mixing Setup Menu	27		
BAS Menu (1 of 2).....	28		
BAS Menu (2 of 2)	29		
Monitor Menu (1 of 3).....	30		
Monitor Menu (2 of 3)	31		
Monitor Menu (3 of 3)	32		
Toolbox Menu	33		
Override Menu.....	34		

Getting Started

Congratulations on the purchase of your new Snow Melting Control!

This manual covers the complete installation, programming and sequence of operation for this control. You will also find instruction on testing, commissioning, and troubleshooting the control and system that it operates.

Important Safety Information

It is your responsibility to ensure that this control is safely installed according to all applicable codes and standards. tekmar is not responsible for damages resulting from improper installation and/or maintenance.



This is a safety-alert symbol. The safety alert symbol is shown alone or used with a signal word (DANGER, WARNING, or CAUTION), a pictorial and/or a safety message to identify hazards. When you see this symbol alone or with a signal word on your equipment or in this manual, be alert to the potential for death or serious personal injury.



This pictorial alerts you to electricity, electrocution, and shock hazards.



WARNING This symbol identifies hazards which, if not avoided, could result in death or serious injury.



CAUTION This symbol identifies hazards which, if not avoided, could result in minor or moderate injury.

NOTICE

This symbol identifies practices, actions, or failure to act which could result in property damage or damage to the equipment.

WARNING



Read manual and all product labels BEFORE using the equipment. Do not use unless you know the safe and proper operation of this equipment. Keep this manual available for easy access by all users. Replacement manuals are available at tekmarControls.com

WARNING

- It is the installer's responsibility to ensure that this control is safely installed according to all applicable codes and standards.
- Improper installation and operation of this control could result in damage to the equipment and possibly even personal injury or death.
- This control is not intended for use as a primary limit control. Other controls that are intended and certified as safety limits must be placed into the control circuit.

NOTICE

Do not attempt to service the control. There are no user serviceable parts inside the control. Attempting to service the control voids the warranty.

Radio Frequency Interference

The installer must ensure that this control and its wiring are isolated and/or shielded from strong sources of electromagnetic noise. Conversely, this Class B digital apparatus complies with Part 15 of the FCC Rules and meets all requirements of the Canadian Interference-Causing Equipment Regulations. However, if this control does cause harmful interference to radio or television reception, which is determined by turning the control off and on, the user is encouraged to try to correct

the interference by re-orientating or relocating the receiving antenna, relocating the receiver with respect to this control, and/or connecting the control to a different circuit from that to which the receiver is connected.

Cet appareil numérique de la classe B respecte toutes les exigences du Règlement sur le matériel brouilleur du Canada.

Installation

Preparation

Tools Required

- tekmar or jeweller screwdriver
- Phillips head screwdriver
- Needle-nose pliers
- Wire stripper

Materials Required

- 18 AWG LVT solid wire (low-voltage connections)
- 14 AWG solid wire (line-voltage connections)
- Four 1/8" - 1" wood screws

Packaging Contents

The following are included in the product packaging:

- 1 Snow Melting Control 680
- 3 Universal Sensor 082
- 1 Outdoor Sensor 070
- 1 screwdriver
- 1 Application Brochure 680_A
- 1 Installation and Operation Manual 680_D
- 1 BAS Integration Manual 680_B

Physical Dimensions

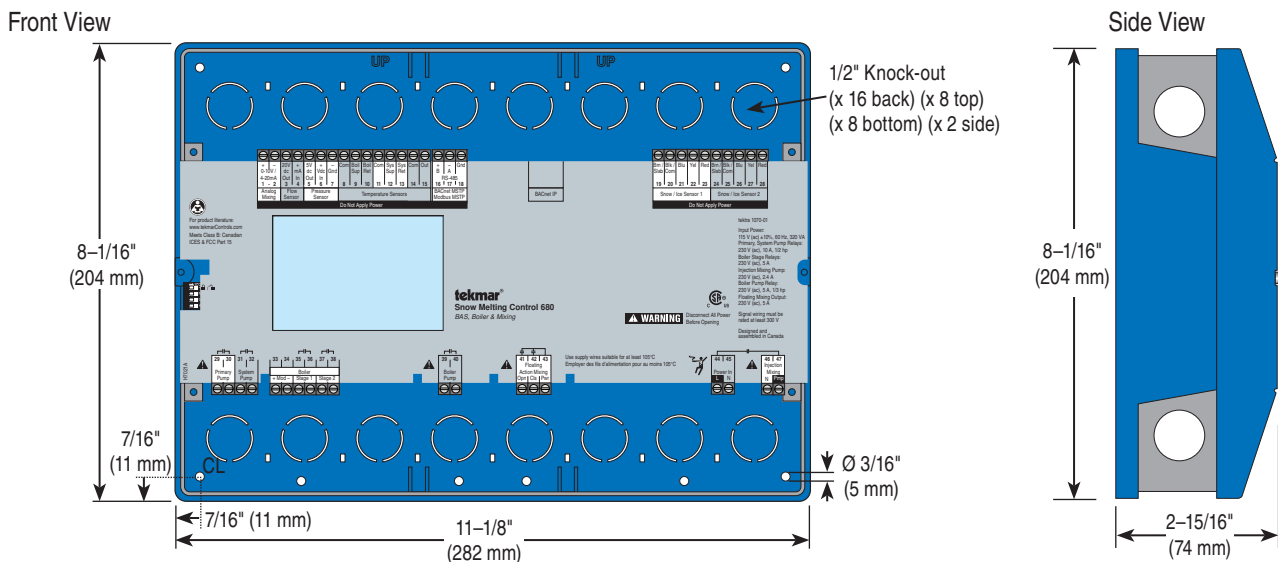

Installation Location

Choose the placement of the control early in the construction process to enable proper wiring during rough-in.

NOTICE

- Keep the control dry. Avoid potential leakage onto the control.
- Maintain relative humidity less than 90% in a non-condensing environment.
- Avoid exposure to extreme temperatures beyond 32-122°F (0-50°C).
- Install away from equipment, appliances, or other sources of electrical interference.
- Install to allow easy access for wiring, viewing, and adjusting the display screen.
- Install approximately 5 feet (1.5 m) off the finished floor.
- Locate the control near pumps and/or zone valves if possible.
- Provide a solid backing which the enclosure can be mounted to. Example: plywood or wall studs.
- Use the conduit knockouts provided on the upper, lower, back and sides of the enclosure for wiring.

Installing the Enclosure

- Install the control enclosure to a wall or to an electrical box.
- Three wiring chamber dividers are included. The dividers provide a barrier to keep low voltage wiring separated from line voltage wiring.
- If the dividers are not used, then low voltage circuits must use wire rated at least 300 V.

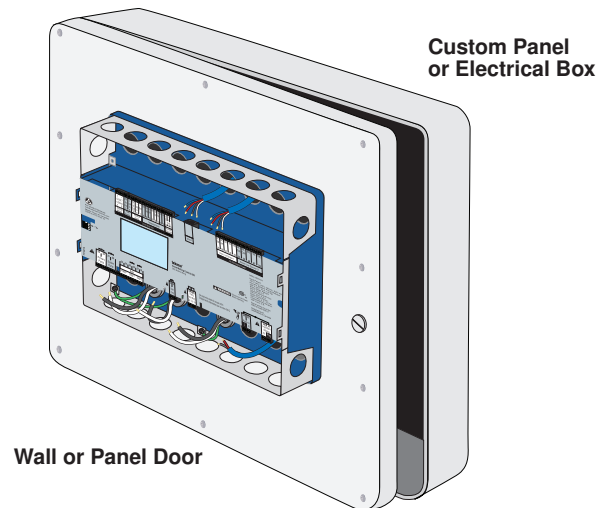

Servicing the Control

In the event that the control requires servicing or replacement, the control can be easily removed from the enclosure. This allows all wiring and conduit to remain installed.

⚠ WARNING



To prevent the risk of personal injury and/or death, make sure power is not applied to the control until it is fully installed and ready for final testing. All work must be done with power to the circuit being worked on turned off. Please be aware local codes may require this control to be installed or connected by an electrician.

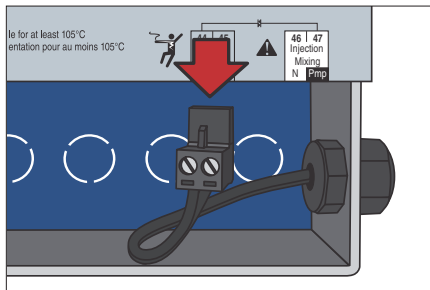

Step 1

Disconnect the wiring terminal plugs by pulling down in the lower wiring chamber and by pulling up in the upper wiring chamber.

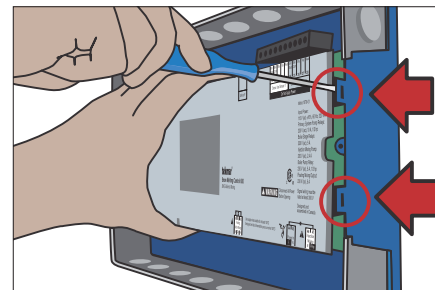

Step 2

There are two tabs located on the right side of the enclosure. Insert a screwdriver into the top of the tab and gently pry the tab away from the control while pulling the control toward you. Repeat for the second tab.

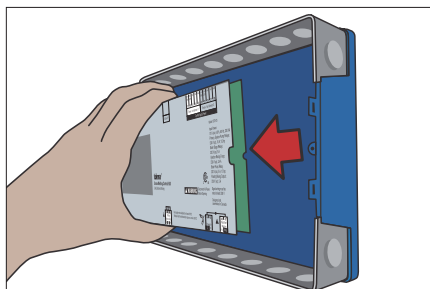

Step 3

Pull the control toward you.

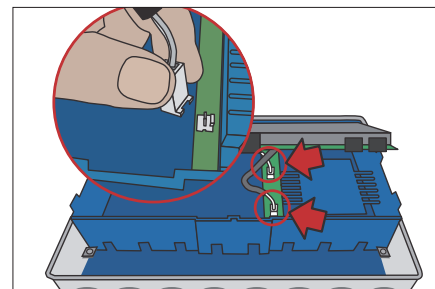

Step 4

Disconnect the two wiring plugs and remove the control.

Step 5

The new control is now ready to be installed in the reverse order.

Rough-In Wiring

⚠ WARNING



To prevent the risk of personal injury and/or death, make sure power is not applied to the control until it is fully installed and ready for final testing. All work must be done with power to the circuit being worked on turned off. Please be aware local codes may require this control to be installed or connected by an electrician.

NOTICE

- Install the supplied wiring compartment barriers by sliding them into the grooves provided to isolate the low and line-voltage wiring.
- Strip all wiring to a length of 3/8 in. or 10 mm for all terminals.
- A circuit breaker or power disconnect that provides power to the control should be located nearby and clearly labeled.
- Refer to the current and voltage ratings at the back of this manual before connecting devices to this control.

Low-Voltage Wiring

Pull two conductor 18 AWG LVT cable, up to 500 feet (150 m) long, for the following equipment:

- Outdoor temperature sensor
- System supply sensor
- System return sensor
- Boiler supply sensor
- Boiler return sensor
- Single-stage on/off boiler
- Modulating boiler 0-10 V (dc) or 4-20 mA
- Mixing valve or mixing injection pump using a 0-10 V (dc) or 4-20 mA signal
- Flow sensor

Pull three conductor 18 AWG LVT cable, up to 500 feet (150 m) long, for the following equipment:

- Mixing valves using a floating action signal
- Pressure sensor

Pull four conductor 18 AWG LVT cable, up to 500 feet (150 m) long, for the following equipment:

- Snow Sensor 095
- Two-stage on/off boiler

Pull the Snow/Ice Sensor 090 or 094 cable to the control.

Line-Voltage Wiring

Pull two conductor 14 AWG cable, up to 500 feet (150 m) long, for the following equipment:

- System pump
- Primary pump
- Boiler pump

Sensor Wiring

Wiring the Analog Mixing Output

The control can operate a mixing valve by providing a 0-10 V (dc) or a 4-20 mA signal to the valve actuating motor.

- If applicable, connect the mixing actuator positive (+) to terminal 1.
- If applicable, connect the mixing actuator negative (-) to terminal 2.

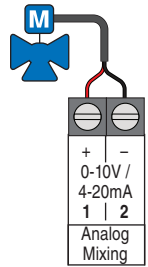

Wiring the Flow Sensor

An analog flow sensor can be connected to the control to provide flow and energy monitoring. The control supports a 4-20 mA style sensor. Examples of compatible aftermarket flow sensors include:

- Kele SDI series
- Kele 200 series with 310 transmitter
- Kele 2200 series
- Kele 3100 series
- Omega FV100 series
- Omega FV-500C series
- Omega FTD-40 series
- Omega FTD-47 transducer

Using the system supply sensor and the boiler return sensor, energy output can be calculated and displayed from the flow measurement. The control provides a 20 V (dc) powered output to the flow sensor.

- Connect the power input on the flow sensor to the 20 V dc Out terminal 3.
- Connect the signal return wire to mA (+) In terminal 4.

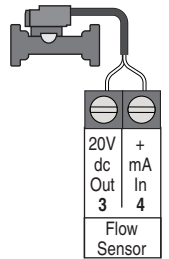

Wiring the Pressure Sensor

An analog pressure sensor can be connected to the control to provide water pressure monitoring. The control supports a 0.5-4.5 ratio metric V (dc) style pressure sensor. Examples of compatible pressure sensors include:

- Honeywell PX2 (AA) series
- Measurement Specialties 7100 series

To connect the pressure sensor to the control:

- Connect one wire from the power supply (+5 V dc) on the pressure sensor to the 5V dc Out terminal 5.
- Connect one wire from the pressure sensor signal output to the Vdc (+) In terminal 6.
- Connect one wire from the GND (0V) on the pressure sensor to the Gnd (-) terminal 7.

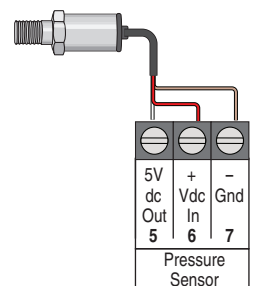

Mounting the Outdoor Sensor

- The temperature sensor (thermistor) is built into the sensor enclosure.
- Remove the screw and pull the front cover off the sensor enclosure.
- The outdoor sensor can either be mounted directly onto a wall or a 2" x 4" electrical box. When the outdoor sensor is wall mounted, the wiring should enter through the back or bottom of the enclosure. Do not mount the outdoor sensor with the conduit knockout facing upwards because rain could enter the enclosure and damage the sensor.
- In order to prevent heat transmitted through the wall from

affecting the sensor reading, it may be necessary to install an insulating barrier behind the enclosure.

- The outdoor sensor should be mounted on a wall which best represents the heat load on the building (a north-facing wall for most buildings and a south-facing wall for buildings with large south-facing glass areas). The outdoor sensor should not be exposed to heat sources such as ventilation or window openings.
- The outdoor sensor should be installed at an elevation above the ground that will prevent accidental damage or tampering.

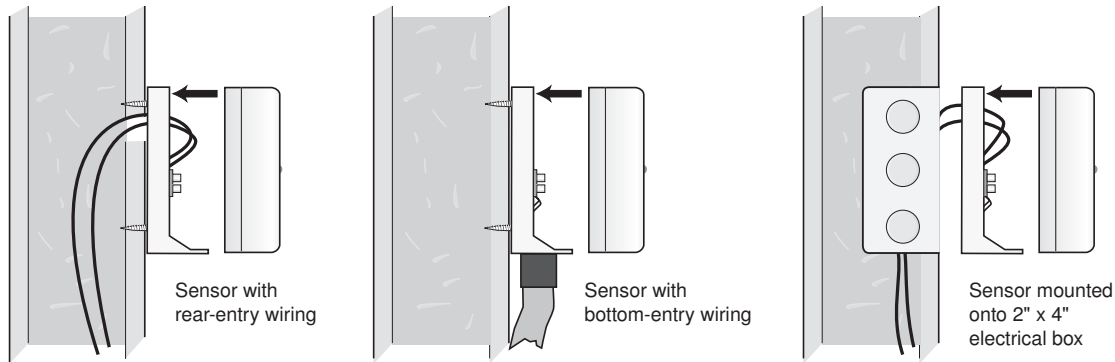

Wiring the Outdoor Sensor

- Connect 18 AWG or similar wire to the two terminals provided in the enclosure and run the wires from the outdoor sensor to the control. Do not run the wires parallel to telephone or power cables. If the sensor wires are located in an area with strong sources of electromagnetic interference (EMI), shielded cable or twisted pair should be used or the wires can be run in a grounded metal conduit. If using shielded cable, the shield wire should be connected to the Com or Com Sen terminal on the control and not to earth ground.
- Follow the sensor testing instructions in this manual and connect the wires to the control.
- Replace the front cover of the sensor enclosure.

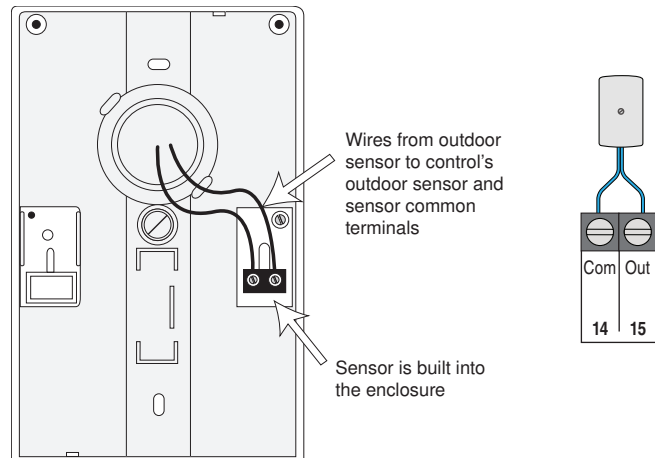

Mounting the Boiler and System Sensors

The Universal Sensor 082 is designed to mount on a pipe or in a temperature immersion well. The sensor should be placed downstream of a pump or after an elbow or similar fitting. This is especially important if large-diameter pipes are used as the thermal stratification within the pipe can result in erroneous sensor readings. Proper sensor location requires that the fluid is thoroughly mixed within the pipe before it reaches the sensor.

Strapped to Pipe

The Universal Sensor can be strapped directly to the pipe using the cable tie provided. Insulation should be placed around the sensor to reduce the effect of air currents on the sensor measurement.

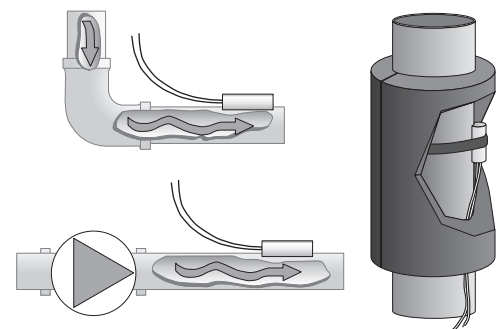

Immersion Well

If a Universal Sensor is mounted onto 1" (25 mm) diameter L type copper pipe, there is approximately an 8 second delay between a sudden change in water temperature and the time the sensor measures the temperature change. This delay increases considerably when mild steel (black iron) pipe is used. In general, it is recommended that a temperature well be used for steel pipe of diameter greater than 1-1/4" (32 mm). Temperature wells are also recommended when large diameter pipes are used and fluid stratification is present.

Conduit Connection

The Universal Sensor and Universal Sensor Enclosure 080 (sold separately) are specifically designed to mount onto a 3/8" (10 mm) ID temperature well that is supplied with an end groove. To install the well, plumb a tee into the pipe and fix the well into the tee. The 080 enclosure has a 7/8" (22 mm) back knockout that must be removed and fitted over the temperature well. The universal sensor is then inserted into the well and the retaining clip supplied with the enclosure is snapped onto the well end groove. If the well has a threaded end, the installer must supply a standard threaded conduit retaining ring. The two wires from the sensor are connected to the terminal block provided in the enclosure. The other side of the terminal block is used to connect wires from the control.

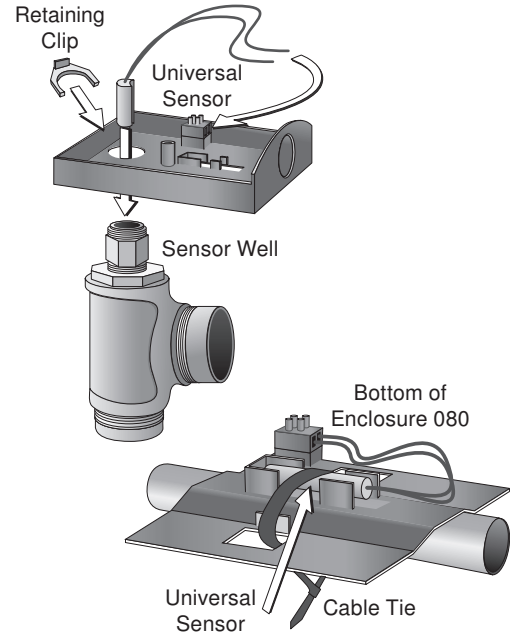

Mounting the Boiler Supply Sensor

The boiler supply sensor is used when operating a boiler.

- If applicable, connect the boiler supply sensor to terminals 8 and 9.

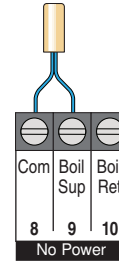

Wiring the Boiler Return Sensor

The boiler return sensor is only used when a mixing valve or variable speed injection mixing is installed. The boiler return sensor protects the boiler from cold return water temperatures.

- If applicable, connect the boiler return sensor to terminals 8 and 10.

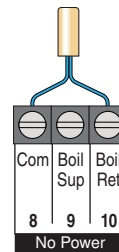

Mounting the System Supply Sensor

The system supply sensor is used in most hydronic applications except when only operating a boiler.

- If applicable, connect the system supply sensor to terminals 11 and 12.

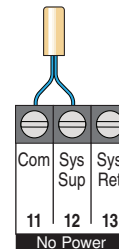

Wiring the System Return Sensor

The system return sensor is used in conjunction with the flow sensor to determine energy consumption. If applicable, connect the system return sensor to terminals 11 and 13.

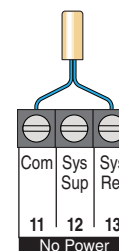

Communication Wiring

BACnet MS/TP and Modbus Communication

A Building Automation System (BAS) can be connected to the control for remote monitoring and adjustment capability. BACnet MS/TP and Modbus communications use an RS-485 connection. Use 18 AWG twisted shielded pair cable. The maximum cable length is dependent on the baud rate and whether terminating resistors are installed. Refer to the *BAS Integration Manual 680_B* for details on the maximum recommended cable length.

- Connect the B (+) terminal on the BAS network to the RS-485 B (+) terminal 16.
- Connect the A (-) terminal on the BAS network to the RS-485 A (-) terminal 17.
- Connect the ground (G) terminal on the BAS network to the Gnd terminal 18.

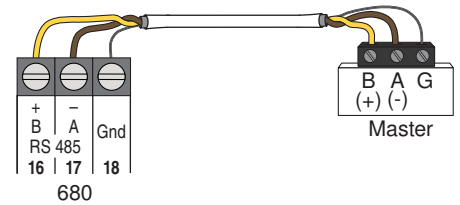

BACnet IP Communication

A Building Automation System (BAS) can be connected to the control for remote monitoring and adjustment capability. BACnet IP communications use an ethernet CAT-5E or CAT-6 cable. The maximum recommended cable length for CAT-5E is 150 feet (45 m) and 300 feet (90 m) for CAT-6.

- Connect the Ethernet RJ45 plug on the BACnet IP network to the ethernet RJ45 jack on the 680.

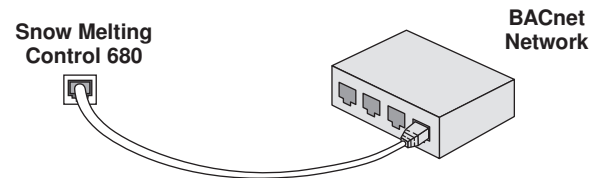

Snow/Ice Sensor

Up to two Snow/Ice Sensor 090 or 094 can be connected to the control. The 090 has a 65' (20 m) cable and the 094 has a 208' (63 m) cable. The cable may be extended to a total length of 500' (150 m) using 18 AWG cable. Any junction boxes must kept dry.

If the Snow/Ice Sensor 1 input is used:

- Connect the brown wire to terminal 19.
- Connect the black wire to terminal 20.
- Connect the blue wire to terminal 21.
- Connect the yellow wire to terminal 22.
- Connect the red wire to terminal 23.

If the Snow/Ice Sensor 2 input is used:

- Connect the brown wire to terminal 24.
- Connect the black wire to terminal 25.
- Connect the blue wire to terminal 26.
- Connect the yellow wire to terminal 27.
- Connect the red wire to terminal 28.

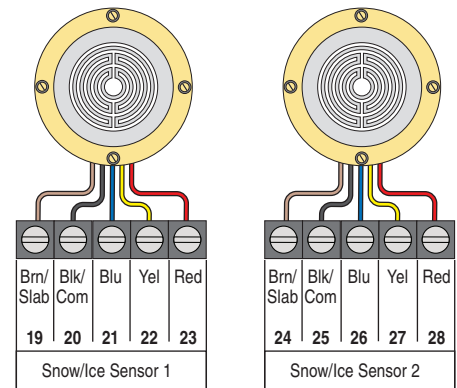

Snow Sensor

Up to two Snow Sensor 095s can be connected to the control.

If the Snow Sensor 1 input is used:

- Connect the black wire to terminal 20.
- Connect the blue wire to terminal 21.
- Connect the yellow wire to terminal 22.
- Connect the red wire to terminal 23.

If the Snow Sensor 2 input is used:

- Connect the black wire to terminal 25.
- Connect the blue wire to terminal 26.
- Connect the yellow wire to terminal 27.
- Connect the red wire to terminal 28.

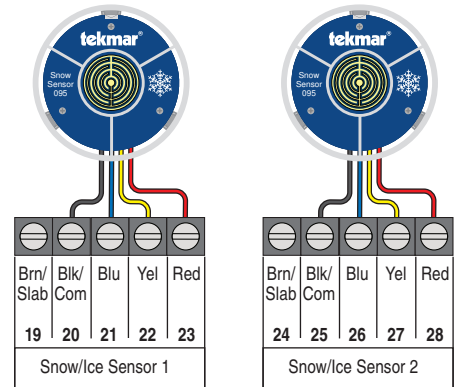

Slab Sensor

A Slab Sensor 072 or 073 can be installed either alone or together with a Snow Sensor 095.

If the Slab Sensor 1 input is used:

Connect the slab sensor to terminals 19 and 20.

If the Slab Sensor 2 input is used:

Connect the slab sensor to terminals 24 and 25.

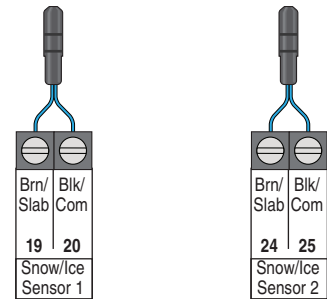

Control Wiring

Wiring the Primary Pump

A primary pump requiring up to 230 V (ac), 10 A, 1/2 hp can be switched through terminals 29 and 30. For simplicity in wiring and troubleshooting, a separate breaker for each pump is recommended.

- Connect the power source line wire (L) to terminal 29.
- Connect a wire from terminal 30 to the pump L.
- Connect a wire from the pump N back to the power source neutral.
- Connect the ground wire (G) to one of the ground screws provided in the wiring chamber.

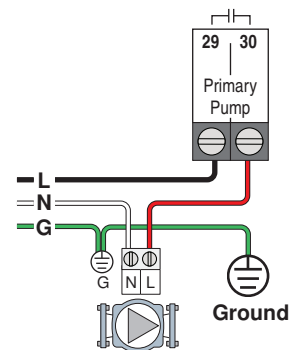

Wiring the System Pump

A system pump requiring up to 230 V (ac), 10 A, 1/2 hp can be switched through terminals 31 and 32. For simplicity in wiring and troubleshooting, a separate breaker for each pump is recommended.

- Connect the power source line wire (L) to terminal 31.
- Connect a wire from terminal 32 to the pump L.
- Connect a wire from the pump N back to the power source neutral.
- Connect the ground wire (G) to one of the ground screws provided in the wiring chamber.

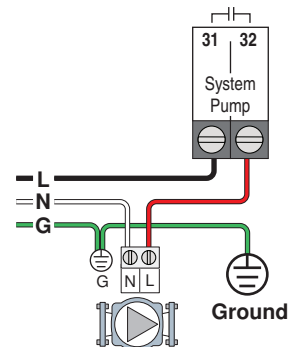

Wiring to a Single-Stage Boiler

A single-stage boiler is enabled through the T-T contacts.

- Connect Stage 1 terminals 35 and 36 to the boiler T-T contacts.

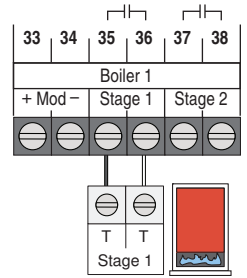

Wiring to a Two-Stage Boiler

A two-stage boiler is enabled through the T-T contacts.

- Connect Stage 1 terminals 35 and 36 to the boiler's stage 1 contacts.
- Connect Stage 2 terminals 37 and 38 to the boiler's stage 2 contacts.

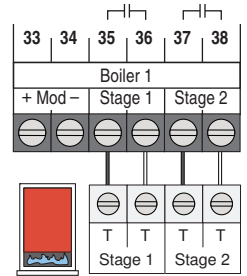

Wiring to a Modulating Boiler

The control provides either a 4-20 mA or a 0-10 V (dc) output to the boiler. Polarity must be observed.

- Connect the Mod + terminal from the boiler to terminal 33.
- Connect the Mod - terminal from the boiler to terminal 34.
- Some modulating boilers require an enable to start firing the boiler. Connect the boiler enable to the stage 1 terminals 35 and 36.

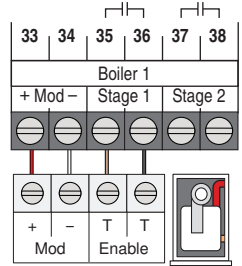

The 4 to 20 mA output can be converted to a 0 - 135 Ω output for a Modutrol IV™ gas valve actuating motor using a 0 - 135 Ω tekmar Converter 005 (sold separately).

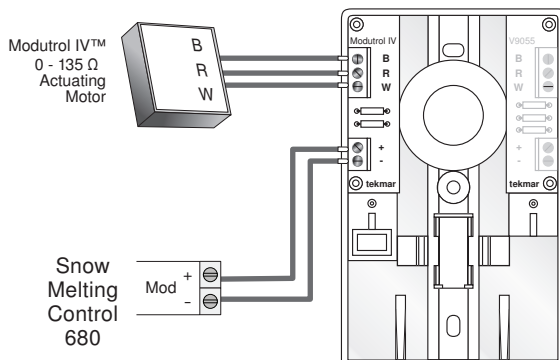

The 4 to 20 mA output can be converted to a 0 - 135 Ω output for a V9055™ gas valve actuating motor using a 0 - 135 Ω tekmar Converter 005 (sold separately).

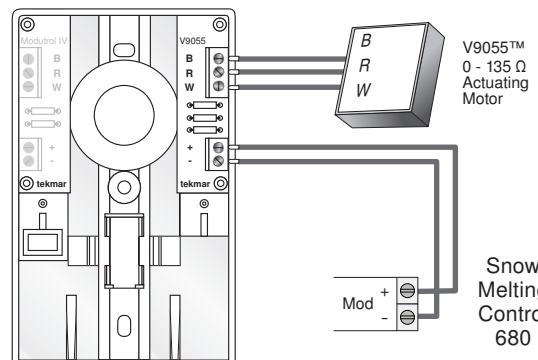

Modutrol IV™ and V9055™ are trademarks of Honeywell, Inc.

Wiring the Boiler Pump

A boiler pump requiring up to 230 V (ac), 5A, 1/3 hp can be switched through terminals 39 and 40. For simplicity in wiring and troubleshooting, a separate breaker for each pump is recommended.

- Connect the power source line wire (L) to terminal 39.
- Connect a wire from terminal 40 to the pump L.
- Connect a wire from the pump N back to the power source neutral.
- Connect the ground wire (G) to one of the ground screws provided in the wiring chamber.

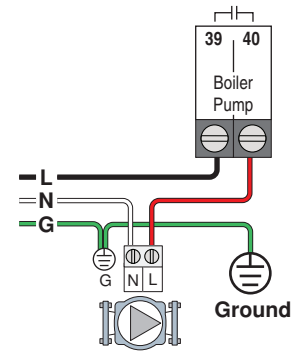

Wiring the Floating Action Mixing Output

The control provides a floating action signal to operate a floating action actuator. The floating action mixing output uses dry relay contacts that can switch either 24, 120, or 230 V (ac). When using 24 V (ac), a Transformer 009 is required to power the actuator. The actuator terminals are typically labelled for clockwise and counterclockwise rotation. The control's open and close terminals are wired to the actuator depending on the direction the valve rotates to open and close respectively.

- Connect the power source to the Pwr terminal 43 on the control.
- Connect the Opn terminal 41 to the actuator terminal that rotates the valve open.
- Connect the Cls terminal 42 to the actuator terminal that rotates the valve close.
- If using a 24 V (ac) transformer, connect the actuator common to the transformer C.
- If using a 120 V or 230 V(ac) power supply, connect the actuator common to the power supply neutral (N).
- If using 120 V or 230 V(ac), connect the ground wire (G) to one of the ground screws provided in the wiring chamber.

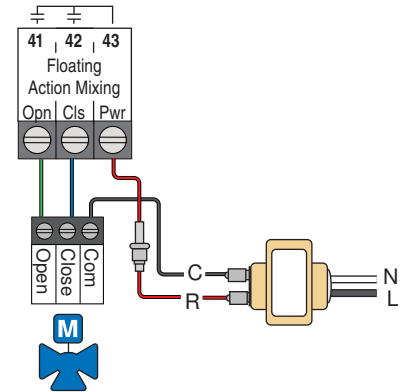

Wiring the Input Power

Provide a 15 A circuit for the input power.

- Connect the 115 V (ac) line wire (L) to terminal 44.
- Connect the neutral wire (N) to terminal 45.
- Connect the ground wire (G) to one of the ground screws provided in the wiring chamber.

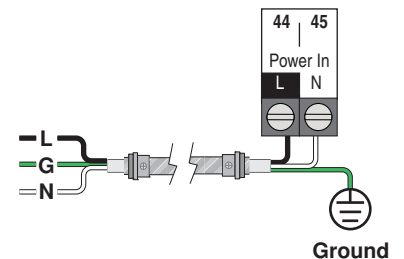

Wiring the Injection Mixing Pump

A variable speed injection mixing pump requiring up to 115 V (ac), 2.4 A is operated through terminals 46 and 47. For simplicity in wiring and troubleshooting, a separate breaker for each pump is recommended.

- Line-voltage is internally supplied through the control.
- Connect a wire from terminal 47 to the pump L.
- Connect a wire from terminal 46 to the pump N.
- Connect the ground wire (G) to one of the ground screws provided in the wiring chamber.

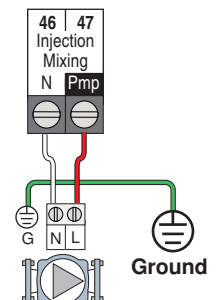

Testing the Sensor Wiring

A good quality test meter capable of measuring up to 5,000 k Ω (1 k Ω = 1000 Ω) is required to measure the sensor resistance. In addition, the actual temperature must be measured with either a high-quality digital thermometer, or if a thermometer is not available, a second sensor can be placed alongside the one to be tested and the readings compared.

First, measure the temperature using the thermometer and then measure the resistance of the sensor at the control. The wires from the sensor must not be connected to the control while the test is performed. Using the chart below, estimate

Temperature		Resistance	Temperature		Resistance	Temperature		Resistance	Temperature		Resistance
$^{\circ}\text{F}$	$^{\circ}\text{C}$	Ω	$^{\circ}\text{F}$	$^{\circ}\text{C}$	Ω	$^{\circ}\text{F}$	$^{\circ}\text{C}$	Ω	$^{\circ}\text{F}$	$^{\circ}\text{C}$	Ω
-50	-46	490,813	20	-7	46,218	90	32	7,334	160	71	1,689
-45	-43	405,710	25	-4	39,913	95	35	6,532	165	74	1,538
-40	-40	336,606	30	-1	34,558	100	38	5,828	170	77	1,403
-35	-37	280,279	35	2	29,996	105	41	5,210	175	79	1,281
-30	-34	234,196	40	4	26,099	110	43	4,665	180	82	1,172
-25	-32	196,358	45	7	22,763	115	46	4,184	185	85	1,073
-20	-29	165,180	50	10	19,900	120	49	3,760	190	88	983
-15	-26	139,403	55	13	17,436	125	52	3,383	195	91	903
-10	-23	118,018	60	16	15,311	130	54	3,050	200	93	829
-5	-21	100,221	65	18	13,474	135	57	2,754	205	96	763
0	-18	85,362	70	21	11,883	140	60	2,490	210	99	703
5	-15	72,918	75	24	10,501	145	63	2,255	215	102	648
10	-12	62,465	80	27	9,299	150	66	2,045	220	104	598
15	-9	53,658	85	29	8,250	155	68	1,857	225	107	553

the temperature measured by the sensor. The sensor and thermometer readings should be close. If the test meter reads a very high resistance, there may be a broken wire, a poor wiring connection or a defective sensor. If the resistance is very low, the wiring may be shorted, there may be moisture in the sensor or the sensor may be defective. To test for a defective sensor, measure the resistance directly at the sensor location.

Do not apply voltage to a sensor at any time as damage to the sensor may result.

Testing the Control Wiring

Remove the front cover from the control.

Testing the Power

- Use an electrical meter set to measure (ac) voltage.
- Measure between the L and N terminals.
- The reading should be 115 V (ac) +/- 10%.

Hand Manual Override

The control includes a Hand Manual Override menu to check if the control's relays are operating and that the control is wired correctly to the snow melting equipment.

Step 1: Press Settings button.

Step 2: Press Override button.

Step 3: Press Manual Override.

Step 4: Select Manual Override to Hand.

Step 5: Press Back button.

Step 6: The following outputs can be operated:

- System Pump relay
- Primary Pump relay
- Boiler Pump relay
- Boiler Stage 1 relay
- Boiler Stage 2 relay
- Boiler Modulation 0-10 V (dc) or 4-20 mA signal
- Mix System Output 0-10 V (dc) or 4-20 mA signal
- Mix System Output floating action relays
- Mix System Output variable-speed injection pump

For each relay output

- Use an electrical meter set to measure (ac) voltage.
- Measure between the relay wiring terminals.
- When the relay is off, the voltage should be 115 V (ac).
- When the relay is on, the voltage should be 0 V (ac).

For the Boiler Modulation

- Use an electrical meter set to measure V (dc) or mA.
- Set the Boiler Modulation to 100%.
- The voltage between the + and – wiring terminals should be 10 V (dc) or 20 mA.
- Set the Boiler Modulation to 0%.
- The voltage between the + and – wiring terminals should be 0 V (dc) or 4 mA.

For the Mix System Output – Floating Action

- Use an electrical meter set to measure (ac) voltage.
- Set the Mix System Output to 100%. The floating action open wiring terminal will be closed for the length of the motor speed setting (default is 105 seconds).
- When opening, the voltage between the open and common wiring terminals should be 24 V (ac) or 115 V (ac).
- When opening, the voltage between the close and common wiring terminals should be 0 V (ac).
- Set the Mix System Output to 0%. The floating action closed wiring terminal will be closed for the length of the motor speed setting (default is 105 seconds).
- When closing, the voltage between the open and common wiring terminals should be 0 V (ac).
- When closing, the voltage between the close and common wiring terminals should be 24 V (ac) or 115 V (ac).

For the Mix System Output – Analog Mixing

- Use an electrical meter set to measure V (dc) or mA.
- Set the Mix System Output to 100%.
- The voltage between the + and – wiring terminals should be 10 V (dc) or 20 mA.
- Set the Mix System Output to 0%.
- The voltage between the + and – wiring terminals should be 0 V (dc) or 4 mA.

For the Mix System Output – Variable Speed Injection Mixing

- Use an electrical meter set to measure V (ac).
- Set the Mix System Output to 100%.
- The voltage between the Pmp and N wiring terminals should be 115 V (ac).
- Set the Mix System Output to 0%.
- The voltage between the Pmp and N wiring terminals should be 0 V (ac).

Exiting the Hand Manual Override

- Exit the Manual Override by selecting Auto.
- Install the front cover.

Manual Override – Maximum Heat

In hydronic application modes, the control includes a Maximum Heat operation where the control operates the snow melting system to maintain the maximum allowed heating setpoints. This allows testing of the snow melting system during warm weather.

- Step 1: Press Settings button.
- Step 2: Press Override button.
- Step 3: Press Manual Override.
- Step 4: Select Manual Override to Max Heat.
- Step 5: Press Back button. The control starts the Max Heat operation.
- Step 6: Exit the Manual Override by selecting Auto.

Manual Override – Purge

When operating a hydronic snow melting system, it is necessary to purge and bleed all air out of the system. The control includes a Purge operation where the system, primary and boiler pumps are all turned on to assist in purging air from the system.

- Step 1: Press Settings button.
- Step 2: Press Override button.
- Step 3: Press Manual Override.
- Step 4: Select Manual Override to Purge.
- Step 5: Press Back button. The control starts the Purge operation.
- Step 6: Exit the Manual Override by selecting Auto.

Manual Override – Test

When operating an electric snow melting system, the control includes a Test operation where the electrical heating cables can be energized for 10 minutes, after which the control resumes normal operation. This allows testing of the electric snow melting system during warm weather.

- Step 1: Press Settings button.
- Step 2: Press Override button.
- Step 3: Press Manual Override.
- Step 4: Select Manual Override to Test.
- Step 5: Press Back button. The control starts the electric test operation for up to 10 minutes before exiting automatically.
- Step 6: Exit the Manual Override by selecting Auto.

Manual Override – Off

The snow melting system can be manually turned off and the control remains off until manually changed back to Auto. This allows the installer or end user to permanently disable the snow melting system without removing power from the control.

- Step 1: Press Settings button.
- Step 2: Press Override button.
- Step 3: Press Manual Override.
- Step 4: Select Manual Override to Off.
- Step 5: Press Back button. The control is now in the off manual override.
- Step 6: Exit the Manual Override by selecting Auto.

Switch Settings

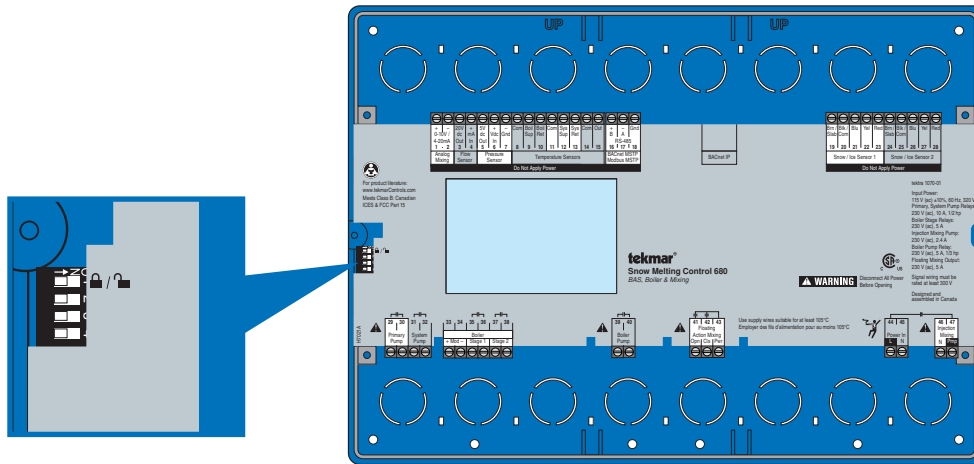

Switch	Position	Action
1	ON	LOCK ACCESS LEVEL The control is locked and the access level cannot be changed. Set to lock when installation has been completed.
	OFF	UNLOCK ACCESS LEVEL The control is unlocked and the access level may be changed. Go to the Toolbox menu to change the access level. Set to unlock during the installation process.
2	ON	Not used
	OFF	Not used
3	ON	Not used
	OFF	Not used
4	ON	Not used
	OFF	Not used

Access Levels and Access Level Lock

The control is shipped pre-programmed with common settings. The control has an “Installer” access level that allows full access to all settings and a “User” access level that restricts the number of settings available. The control defaults to the “User” access level after 12 hours of operation.

To change to the “Installer” access level:

- Step 1: Press the Settings button.
- Step 2: Press the Toolbox button.
- Step 3: Press Access Level.
- Step 4: Press the Installer radio button.

User Interface

Home Screen

The Home Screen UI consists of a central panel with the following elements:

- Time Remaining**: -- : -- hours (Callout: Remaining melting run time)
- Slab 1**: 23 °F (Callout: Slab and outdoor conditions information)
- System is Melting**: Warming Up (Callout: System operation information)
- Buttons**: Settings, Stop, Status (Callout: Touchscreen buttons)

System Operation

<p>Time Remaining -- : -- hours Slab 1 23 °F</p> <p>System is Melting Warming Up</p> <p>Settings Stop Status</p>	<p>SYSTEM IS MELTING</p> <ul style="list-style-type: none"> Warming Up: The slab has not yet reached the slab target temperature.
<p>Time Remaining -- : -- hours Slab 1 25 °F</p> <p>System is Off</p> <p>Settings Melt Status</p>	<p>SYSTEM IS OFF</p> <ul style="list-style-type: none"> Warm Weather Shut Down: The slab and outdoor temperature have exceeded the WWSD setting. Cold Weather Cut Off: The outdoor temperature has fallen below the CWCO setting. Melt Pending: System will resume melting once outdoor temperature increases above the CWCO setting.
<p>Time Remaining -- : -- hours Outdoor 32 °F</p> <p>System is Idling</p> <p>Settings Melt Status</p>	<p>SYSTEM IS IDLING</p>
<p>Time Remaining -- : -- hours Outdoor 32 °F</p> <p>Storm Predicted</p> <p>Settings Melt Status</p>	<p>STORM PREDICTED</p>
<p>Time Remaining -- : -- hours Outdoor 32 °F</p> <p>System in Override Hand</p> <p>Settings Melt Status</p>	<p>SYSTEM IN OVERRIDE</p> <ul style="list-style-type: none"> Hand: The control is in hand manual override. Max Heat: The control is operating at Max Heat for hydronic systems. Purge: The control is purging air from the hydronic system. Test: The electric heating cable is in manual override. Off: The system is permanently off.
<p>Time Remaining -- : -- hours Outdoor 32 °F</p> <p>System in Exercising System Pump</p> <p>Settings Melt Status</p>	<p>SYSTEM IN EXERCISING</p> <ul style="list-style-type: none"> Opening Mixing: Mixing valve is opening. Closing Mixing: Mixing valve is closing. System Pump: System pump is exercising. Primary Pump: Primary pump is exercising. Boiler Pump: Boiler pump is exercising. Injection Pump: Injection pump is exercising.

Symbols



WARNING SYMBOL

The control has an error message. Press the warning symbol to determine the error code and information on how to take corrective action. Refer to the Troubleshooting section for a list of error codes.

Help Screen

The display includes a Help screen for each setting. The Help screen provides a description of the setting that is identical to the description found in the Installation and Operation Manual.

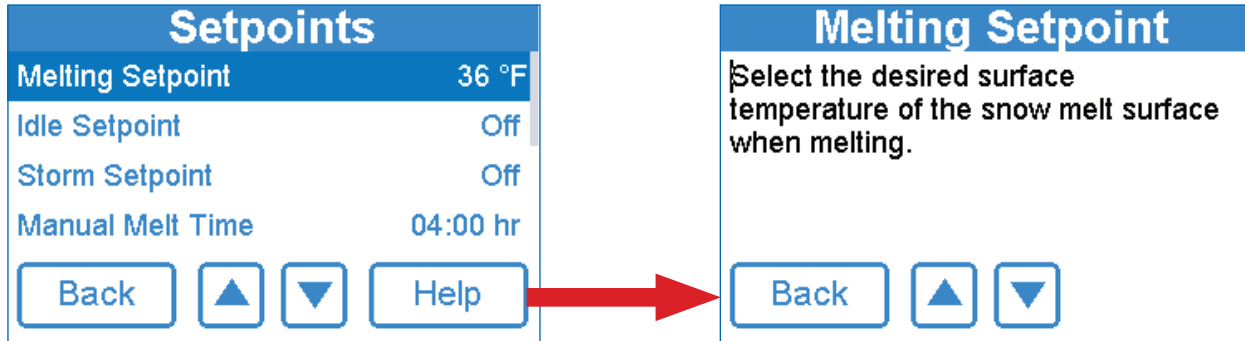

Status Menu Navigation

- Step 1: Press the Status button on the Home Screen.
- Step 2: Press either the System or Slab button.
- Step 3: Press up or down buttons to scroll through the list.

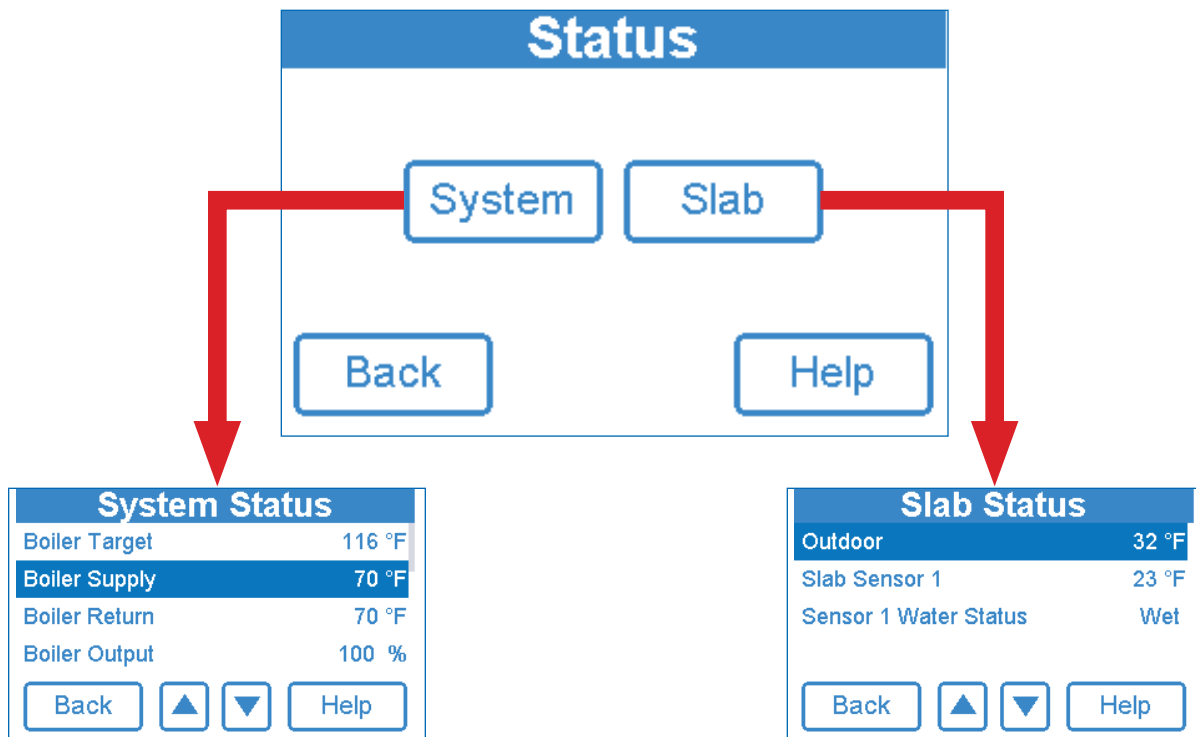

Slab Status Screen

Description	Range	Access
<p>OUTDOOR Current outdoor air temperature as measured by the outdoor sensor or provided by the BAS system. "----" is displayed when no outdoor sensor is available. Conditions: Always available.</p>	<p>---, -67 to 149°F (-55.0 to 65.0°C)</p>	<p>User Installer</p>
<p>SLAB TARGET The slab target calculated by the control based on outdoor temperature and the melting, idling, or storm setpoints. "- - -" is displayed when no heat is required. Conditions: Always available.</p>	<p>---, -76 to 149°F (-60.0 to 65.0°C)</p>	<p>Installer</p>
<p>SLAB SENSOR 1 Current slab sensor 1 temperature. Conditions: Snow/ice sensor 1 set to In-slab or Slab sensor 1 is set to On.</p>	<p>-58 to 167°F (-50.0 to 75.0°C)</p>	<p>User Installer</p>
<p>SENSOR 1 WATER STATUS Current status of snow/ice sensor 1 moisture detector. Conditions: Snow/ice sensor 1 is set to In-slab or Aerial.</p>	<p>DRY or WET</p>	<p>User Installer</p>
<p>SLAB SENSOR 2 Current slab sensor 2 temperature. Conditions: Snow/ice sensor 2 is set to In-slab or Snow sensor 2 is set to On.</p>	<p>-58 to 167°F (-50.0 to 75.0°C)</p>	<p>User Installer</p>
<p>SENSOR 2 WATER STATUS Current status of snow/ice sensor 2 moisture detector. Conditions: Snow/ice sensor 2 is set to In-slab or Aerial.</p>	<p>DRY or WET</p>	<p>User Installer</p>
<p>COLDEST SLAB The coldest temperature between the two slab sensors. Conditions: 1) Snow/ice sensor 1 is set to In-slab or slab sensor 1 is set to On, and 2) snow/ice sensor 2 is set to In-slab or slab sensor 2 is set to On.</p>	<p>-58 to 167°F (-50.0 to 75.0°C)</p>	<p>User Installer</p>
<p>COMBINED WATER STATUS Combined status of both snow/ice sensor 1 and 2 moisture detectors. If either sensor is wet then the status is "Wet". Conditions: Snow/ice sensor 1 and 2 are both set to In-slab or Aerial.</p>	<p>DRY or WET</p>	<p>User Installer</p>

System Status Menu (1 of 2)

Description	Range	Access
BOILER TARGET The boiler target calculated by the control based on outdoor temperature, slab temperature and the melting, idling, or storm setpoints. "--" is displayed when no heat is required. Conditions: Application mode is set to Boiler or Boiler+Mix.	---, 50 to 230°F (10.0 to 110.0°C)	User Installer
BOILER SUPPLY Current boiler supply water temperature. Conditions: Application mode is set to Boiler or Boiler+Mix.	-31 to 266°F (-35.0 to 130.0°C)	Installer
BOILER RETURN Current boiler return water temperature. Conditions: Application mode is set to Boiler or Boiler+Mix.	-31 to 266°F (-35.0 to 130.0°C)	User Installer
BOILER OUTPUT Current boiler plant percent output. Conditions: Application mode is set to Boiler or Boiler+Mix.	0 to 100%	User Installer
STAGE 1 Current status of the stage 1 relay. Conditions: Application mode is set to PWM Zone, Mixing, Boiler, or Boiler+Mix.	On or Off	User Installer
STAGE 2 Current status of the stage 2 relay. Conditions: Boiler type is set to Stage 2.	On or Off	User Installer
PRIMARY PUMP Current status of the primary loop pump. Conditions: Application mode is set to PWM Zone, Boiler or Boiler+Mix.	On or Off	User Installer
BOILER PUMP Current status of the boiler loop pump. Conditions: Application mode is set to Boiler or Boiler+Mix and the Boiler type is not set to Off.	On or Off	User Installer
MIX SYSTEM TARGET The mix system target calculated by the control based on outdoor temperature, slab temperature and one of either the melting, idling, or storm setpoints. "--" is displayed when no heat is required. Conditions: Application mode is set to Mixing or Boiler+Mix.	---, 70 to 200°F (21.0 to 93.5°C)	User Installer
SYSTEM SUPPLY Current system supply water temperature. Conditions: Application mode is not set to Electric.	-31 to 266°F (-35.0 to 130.0°C)	User Installer
SYSTEM RETURN Current system return water temperature. Conditions: 1) Application mode is set to PWM Zone, Mixing or Boiler+Mix and 2) a system return sensor is installed.	-31 to 266°F (-35.0 to 130.0°C)	User Installer
MIX SYSTEM OUTPUT Current position of the mixing valve or output of the variable speed injection pump. Conditions: Application mode is set to Mixing or Boiler+Mix.	0 to 100%	User Installer

System Status Menu (2 of 2)

Description	Range	Access
SYSTEM PUMP Current status of the system loop pump. Conditions: Application mode is set to PWM Zone, Mixing or Boiler+Mix.	On or Off	User Installer
SYSTEM FLOW RATE The system flow rate measured by the flow meter. Conditions: 1) Application mode is set to PWM Zone, Boiler, Mixing or Boiler+Mix and 2) Flow sensor is set to On.	0 to 1000 GPM (0 to 227 m ³ /h)	User Installer
SYSTEM PRESSURE The system pressure measured by the pressure sensor. Conditions: Application mode is set to PWM Zone, Boiler, Mixing or Boiler+Mix, and 2) a Pressure Sensor is installed.	0 to 300 psi (0 to 2069 kPa)	User Installer
ELECTRIC ENABLE RELAY Current status of the electric snow melt enable relay. Conditions: Application mode is set to Electric.	On or Off	User Installer

Settings Menu Navigation

Step 1: Press the Settings button on the Home Screen.

Step 2: Press one of the six buttons.

Step 3: Press up or down buttons to scroll through the list.

Step 4: Press the highlighted setting name to change the setting value.

In the BAS menu, settings using a number keypad require touching the number field and then pressing the "Clear" button before entering the number.

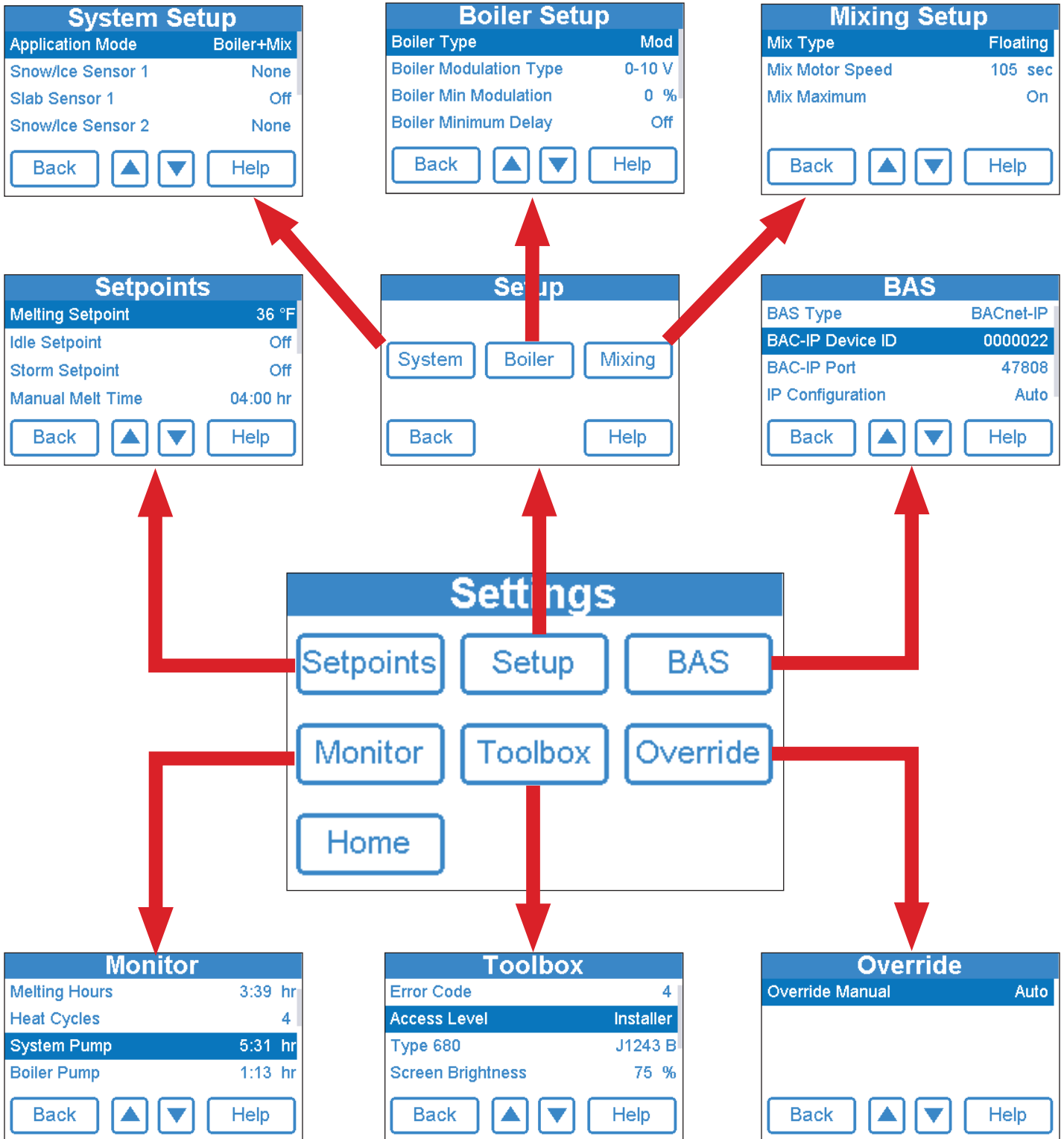

Setpoints Menu		
Description	Range	Access
<p>MELTING SETPOINT Select the desired temperature of the snow melt surface when melting. Conditions: Always available.</p>	32 to 95°F (0.0 to 35.0°C) Default = 36°F (2.0°C)	User Installer
<p>IDLING SETPOINT Select the desired temperature of the snow melt surface when idling. Idling pre-heats the slab when the slab is dry but cold and allows faster reaction time to reach the melting temperature when snow is detected. Recommended for commercial use only. Conditions: Always available.</p>	OFF, 20 to 95°F (-6.5 to 35.0°C) Default = Off	User Installer
<p>STORM SETPOINT Select the desired temperature of the snow melt surface while operating in the storm operation. Storm operation temporarily pre-heats the slab to allow faster reaction time to reach the melting temperature when snow is detected. Storm operation is activated through a BACnet or Modbus command. Conditions: Always available.</p>	OFF, 20 to 95°F (-6.5 to 35.0°C) Default = Off	User Installer
<p>MANUAL MELT TIME Select the amount of running time when manually starting the system. Conditions: Always available.</p>	0:30 to 24:00 hours Default = 4:00 hours	User Installer
<p>ADD MELT TIME Select the amount of additional melting time after the Snow/Ice Sensors are dry. This allows low spots on the slab to fully dry before the snow melting system is shut off. Conditions: 1) Snow/ice sensor 1 is set to In-slab or Aerial, or 2) Snow/ice sensor 2 is set to In-slab or Aerial.</p>	0:00 to 6:00 hours Default = 0:00 hours	Installer
<p>STORM RUN TIME Select the amount of storm run time to pre-heat the slab when advised of a winter storm warning. Conditions: Storm setpoint is set to a temperature.</p>	0:30 to 24:00 hours Default = 8:00 hours	Installer
<p>SENSITIVITY 1 Select how sensitive Snow/Ice Sensor 1 is to water detection. Conditions: Snow/ice sensor 1 is set to In-slab or Aerial.</p>	Auto, Min, -2, -1, Mid, +1, +2, Max Default = Auto	Installer
<p>SENSITIVITY 2 Select how sensitive Snow/Ice Sensor 2 is to water detection. Conditions: Snow/ice sensor 2 is set to In-slab or Aerial.</p>	Auto, Min, -2, -1, Mid, +1, +2, Max Default = Auto	Installer
<p>WWSD Select the temperature above which the snow melting system is shut off during warm weather. This allows the snow or ice to melt off the slab naturally. Conditions: Always available.</p>	Auto, 32 to 95°F (0.0 to 35.0°C) Default = Auto	Installer
<p>CWCO Select the temperature below which the snow melting system is shut off during extremely cold weather. Below this temperature, the heat loss of the slab exceeds the capacity of the boiler or heating appliance. Conditions: Always available.</p>	Off, -30 to 50°F (-34.5 to 10.0°C) Default = 10°F (-12.0°C)	Installer

Setup – System Setup Menu (1 of 2)

Description	Range	Access
<p>APPLICATION MODE The Application Mode selects the operation of the mechanical equipment. Application Mode “PWM Zone” operates a pump or zone valve to provide heat to the snow melting system.</p> <p>Application Mode “Mixing” operates a mixing valve or a variable speed injection mixing pump to heat the snow melting system. The heat source is enabled.</p> <p>Application Mode “Boiler” operates a modulating, 1-stage or 2-stage boiler to heat the snow melting system.</p> <p>Application Mode “Boiler+Mix” operates a mixing valve or a variable speed injection mixing pump and controls the boiler temperature to heat the snow melting system.</p> <p>Application Mode “Electric” uses electric cables to heat the snow melting system. Conditions: Always available.</p>	<p>PWM Zone Mixing Boiler Boiler+Mix Electric</p> <p>Default = Boiler+Mix</p>	<p>Installer</p>
<p>SNOW/ICE SENSOR 1 Select if a Snow/Ice Sensor 090 or 094 (In-slab), or a Snow Sensor 095 (Aerial) is installed on the Snow/Ice Sensor 1 input. Conditions: Always available.</p>	<p>None, In-slab, Aerial Default = In-slab</p>	<p>Installer</p>
<p>SLAB SENSOR 1 Select if a Slab Sensor 072 or 073 is installed on the Slab Sensor 1 input. Conditions: Available when snow/ice sensor 1 is set to None or Aerial.</p>	<p>Off or On Default = Off</p>	<p>Installer</p>
<p>SNOW/ICE SENSOR 2 Select if a Snow/Ice Sensor 090 or 094 (In-slab), or a Snow Sensor 095 (Aerial) is installed on the Snow/Ice Sensor 2 input. Conditions: Always available.</p>	<p>None, In-slab, Aerial Default = None</p>	<p>Installer</p>
<p>SLAB SENSOR 2 Select if a Slab Sensor 072 or 073 is installed on the Slab Sensor 2 input. Conditions: Available when snow/ice sensor 2 is set to None or Aerial.</p>	<p>Off or On Default = Off</p>	<p>Installer</p>
<p>SLAB PROTECTION Select if a concrete slab should be protected from large temperature differentials to avoid cracking the concrete due to high tensile stress. This limits the heat-up rate of the concrete slab. Slab protection is not required for installations with brick pavers, asphalt or other non-concrete materials. Conditions: Available when 1) Application mode is set to Mixing, Boiler or Boiler+Mix, 2) Snow/ice sensor 1 or 2 is set to 090 or Slab sensor 1 or 2 is set to On.</p>	<p>Off or On Default = On</p>	<p>Installer</p>
<p>ECONOMELT EconoMelt allows the user to mechanically remove snow then manually start the system to melt the remaining thin snow layer or ice. Conditions: Available when snow/ice sensor 1 or 2 is set to In-slab.</p>	<p>Off or On Default = Off</p>	<p>Installer</p>
<p>MAX MELT DAYS Limit the amount of melting run time after snow is automatically detected by a Snow/Ice Sensor 090 or 094, or a Snow Sensor 095. Conditions: Always available.</p>	<p>Off, 0.5 to 7 days Default = 3 days</p>	<p>Installer</p>
<p>OUTDOOR SENSOR Select if the outdoor air temperature is measured by the control or if the BAS system communicates the outdoor air temperature. Conditions: Always available.</p>	<p>Control or BAS Default = Control</p>	<p>Installer</p>

Setup – System Setup Menu (2 of 2)

Description	Range	Access
<p>PRESSURE SENSOR Select if a pressure sensor is installed. Conditions: Available when the Application Mode is not set to Electric.</p>	Off or On Default = Off	Installer
<p>PRESSURE RANGE Select the maximum pressure rating of the installed pressure sensor. Conditions: Available when 1) The Application Mode is not set to Electric, and 2) Pressure Sensor is set to On.</p>	50, 100, 150, 200, 250, 300 (345, 690, 1034, 1379, 1724, 2069 kPa) Default = 50 psi (345 kPa)	Installer
<p>LOW PRESSURE WARNING Select the low pressure limit below which a warning message is generated. Conditions: Available when 1) The Application Mode is not set to Electric, and 2) Pressure Sensor is set to On.</p>	Off, 5 to 25 psi (35 to 173 kPa) Default = Off	Installer
<p>FLOW SENSOR Select whether a flow sensor is installed. Conditions: Available when the Application Mode is not set to Electric.</p>	Off or On Default = Off	Installer
<p>FLOW @ 4 mA Select the flow rate when the meter's signal is 4 mA. Conditions: Available when 1) The Application Mode is not set to Electric, and 2) Flow Sensor is set to On.</p>	1 to 100 GPM (0 to 27 m ³ /h) Default = 1 GPM (0 m ³ /h)	Installer
<p>FLOW @ 20 mA Select the flow rate when the meter's signal is 20 mA. Conditions: Available when 1) The Application Mode is not set to Electric, and 2) Flow Sensor is set to On.</p>	1 to 1000 GPM (0 to 272 m ³ /h) Default = 50 GPM (11.36 m ³ /h)	Installer
<p>GLYCOL TYPE Select the type of glycol solution in the snow melt system. The type of glycol solution affects the energy meter calculation. Conditions: Available when 1) The Application Mode is not set to Electric, and 2) Flow Sensor is set to On.</p>	Ethylene or Propylene Default = Ethylene	Installer
<p>PERCENT GLYCOL Select the percent mixture of the glycol solution. The percent glycol solution affects the energy meter calculation. Conditions: Available when 1) The Application Mode is not set to Electric, and 2) Flow Sensor is set to On.</p>	10 to 70% Default = 40%	Installer
<p>ELECTRIC LOAD Set the size of the electric heating load in kilowatts for this zone. Conditions: Application mode is set to Electric.</p>	0 to 200 kW Default = 35kW	Installer

Setup – Boiler Setup Menu (1 of 2)

Description	Range	Access
<p>BOILER TYPE Select the type of boiler operated by the control. Mod = Modulating boiler with an adjustable firing rate using a 0-10V (dc) or 4-20 mA signal. 1 Stage = Single one-stage on/off boiler. 2 Stage = Single two-stage on/off boiler. EMS = Modulating boiler with an adjustable target temperature using a 0-10V (dc) or 4-20 mA signal. Conditions: Application Mode is set to Boiler or Boiler+Mix.</p>	Mod, 1 Stage, 2 Stage, EMS Default = Mod	Installer
<p>BOILER MODULATION TYPE Select between a 0-10 V (dc) or 4-20 mA signal to control the modulating boiler. Conditions: Available when 1) Application Mode is set to Boiler or Boiler+Mix, and 2) Boiler Type is set to Mod or EMS.</p>	0-10 V or 4-20 mA Default: 0-10 V	Installer
<p>BOILER MIN MODULATION Set the boiler minimum modulation of the boiler burner. Conditions: Available when 1) Application Mode is set to Boiler or Boiler+Mix, and 2) Boiler Type is set to Mod or EMS.</p>	0 to 50% Default = 0%	Installer
<p>BOILER MODULATION DELAY Set the time the boiler operates at the minimum firing rate before allowing the firing rate to change. This allows the boiler ignition system to establish a flame. Conditions: Available when 1) Application Mode is set to Boiler or Boiler+Mix, and 2) Boiler Type is set to Mod or EMS.</p>	Off, 10 to 180 seconds Default = Off	Installer
<p>BOILER MOTOR SPEED Set the time required for the modulating burner actuating motor to fully open the gas valve or ramp the burner fan speed from off to full speed. Set to 30 seconds unless otherwise recommended by the boiler manufacturer. Conditions: Available when 1) Application Mode is set to Boiler or Boiler+Mix, and 2) Boiler Type is set to Mod.</p>	30 to 230 seconds Default = 30	Installer
<p>BOILER DIFFERENTIAL The temperature differential that the control uses to cycle the boiler on and off. The differential is split evenly half above and half below of the boiler target. Conditions: Available when Application Mode is set to Boiler or Boiler+Mix.</p>	Auto, 2 to 42°F (1.0 to 23.5°C) Default = Auto	Installer
<p>BOILER MINIMUM The boiler return minimum protects both condensing and non-condensing boilers from cold return water temperatures. The mixing valve is closed or the variable speed injection mixing is reduced when the boiler return temperature falls below this setting. Conditions: Available when Application Mode is set to Mixing or Boiler+Mix.</p> <p>The minimum allowed boiler target temperature. Check the boiler manufacturer's manual for recommended return water temperatures. Conditions: Available when Application Mode is set to Boiler.</p>	Off, 50 to 180°F (10.0 to 82.0°C) Default = Off	Installer
<p>EMS SIGNAL MINIMUM The starting voltage for the EMS modulating boiler signal. This voltage corresponds to the EMS Low Temperature setting. Check the boiler manufacturer's manual for the starting voltage for the EMS signal range. Conditions: Available when 1) Boiler Type is set to EMS, and 2) Boiler Modulation Type is set to 0-10 V.</p>	0.5 to 10 Vdc Default = 0.5 Vdc	Installer
<p>EMS LOW TEMPERATURE The EMS modulating boiler target temperature that corresponds to the EMS Signal Minimum voltage or 4 mA. Check the boiler manufacturer's manual for the minimum EMS target temperature. Conditions: Available when Boiler Type is set to EMS.</p>	50 to 210°F (10 to 99.0°C) Default = 50°F (10.0°C)	Installer

Setup – Boiler Setup Menu (2 of 2)

Description	Range	Access
<p>EMS HIGH TEMPERATURE The EMS modulating boiler target temperature that corresponds to 10 V (dc) or 20 mA. Check the boiler manufacturer's manual for the maximum EMS target temperature. Conditions: Available when Boiler Type is set to EMS.</p>	50 to 210°F (10.0 to 99.0°C) Default = 210°F (99.0°C)	Installer

Setup – Mixing Setup Menu

Description	Range	Access
<p>MIXING TYPE Select the mixing output type. Floating = Floating action mixing output to operate a mixing valve. Injection = Injection mixing output to operate a wet-rotor, impedance protected pump with a current less than 2.4 A. 0-10 V = Analog mixing output provides a 0-10 V (dc) signal. 4-20 mA = Analog mixing output provides a 4-20 mA signal. Conditions: Available when Application Mode is set to Mixing or Boiler+Mix.</p>	Floating, Injection, 0-10 V, or 4-20 mA Default = Floating	Installer
<p>MIX MOTOR SPEED Set the time that the mixing actuating motor requires to operate from fully closed to fully open. Check the mixing actuator motor instruction manual for the motor speed time. Conditions: Available when 1) Application Mode is set to Mixing or Boiler+Mix, and 2) Mixing Type is set to Floating, 0-10 V, or 4-20 mA.</p>	30 to 230 seconds Default = 105 seconds	Installer
<p>MIX MAXIMUM Set the maximum operating temperature of the system supply water temperature. Conditions: Available when Application Mode is set to Mixing or Boiler+Mix.</p>	80 to 180°F, Off (26.5 to 82.5°C) Default = 140°F (60.0°C)	Installer

BAS Menu (1 of 2)

Settings using a number keypad require touching the number field and then pressing the "Clear" button before entering the number.

Description	Range	Access
<p>BAS TYPE Select the communication protocol used with the BAS network. None = No communication. The control operates in stand-alone. BACnet-IP = The control communicates to a BACnet-IP BAS system. BACnet-MSTP = The control communicates to a BACnet-MSTP BAS system. Modbus = The control communicates to a Modbus BAS system. Conditions: Always available.</p>	None, BACnet-IP, BACnet-MSTP, Modbus Default = None	Installer
<p>BACnet-IP DEVICE ID Select the BACnet-IP device identification number. Each device on the BACnet system must have a unique identification number. Conditions: Available when BAS Type is set to BACnet-IP.</p>	0 to 4194302 Default = 1	Installer
<p>BACnet-IP PORT Select the BACnet-IP port number. The default BACnet port is 47808 (0xBAC0 in hexadecimal). Conditions: Available when BAS Type is set to BACnet-IP.</p>	0 to 65535 Default = 47808	Installer
<p>IP CONFIGURATION Select if Dynamic Host Configuration Protocol (DHCP) is used to automatically provide an IP address (Auto) or use a manually set IP address (manual) on the BACnet-IP network. The Help screen shows the following information: <ul style="list-style-type: none"> • IP Configuration • IP Address • Subnet Mask • Gateway IP • Link Status • Speed Status Conditions: Available when BAS Type is set to BACnet-IP.</p>	Manual or Auto Default = Auto	Installer
<p>IP ADDRESS Set the IP address on the BACnet-IP network. All BACnet devices must share the same subnet in order to communicate. Conditions: Available when 1) BAS Type is set to BACnet-IP, and 2) IP Configuration is set to Manual.</p>	000.000.000.000 to 255.255.255.254 Default = 192.168.0.200	Installer
<p>IP SUBNET MASK Set the subnet mask on the BACnet-IP network. Conditions: Available when 1) BAS Type is set to BACnet-IP, and 2) IP Configuration is set to Manual.</p>	000.000.000.000 to 255.255.255.254 Default = 255.255.255.0	Installer
<p>IP GATEWAY Set the Gateway IP address on the BACnet-IP network. All BACnet devices must share the same subnet in order to communicate. Conditions: Available when 1) BAS Type is set to BACnet-IP, and 2) IP Configuration is set to Manual.</p>	000.000.000.000 to 255.255.255.254 Default = 192.168.0.1	Installer
<p>REGISTER FOREIGN DEVICES Select if a BACnet Broadcast Management Device (BBMD) is on the BACnet network. Conditions: Available when BAS Type is set to BACnet-IP.</p>	Off or On Default = Off	Installer

BAS Menu (2 of 2)

Description	Range	Access
<p>BBMD PORT Set the BACnet Broadcast Management Device (BBMD) UDP port on the BACnet network. Conditions: Available when BAS Type is set to BACnet-IP.</p>	<p>0 to 65535 Default = 47808</p>	<p>Installer</p>
<p>BBMD TIME Set the BACnet Broadcast Management Device (BBMD) time-to-live in seconds for foreign device registration on a BACnet network. Conditions: Available when 1) BAS Type is set to BACnet-IP, and 2) Register Foreign Device is set to On.</p>	<p>30 to 65535 seconds Default = 30 seconds</p>	<p>Installer</p>
<p>BBMD IP Set the BACnet Broadcast Management Device (BBMD) IP address on the BACnet network. Conditions: Available when 1) BAS Type is set to BACnet-IP, and 2) Register Foreign Device is set to On.</p>	<p>000.000.000.000 to 255.255.255.254 Default = 127.127.127.127</p>	<p>Installer</p>
<p>MAC ADDRESS This is the Media Access Control (MAC) address of this product. Conditions: Available when BAS Type is set to BACnet-IP.</p>	<p>XX:XX:XX:XX: XX:XX</p>	<p>Installer</p>
<p>BACnet-MSTP DEVICE ID Set the BACnet MSTP device identification number. Each device on the BACnet network must have a unique identification number. Conditions: Available when BAS Type is set to BACnet-MSTP.</p>	<p>0 to 4194302 Default = 1</p>	<p>Installer</p>
<p>BACnet-MSTP ADDRESS Set the MSTP address. Each MSTP device must have a unique address. Conditions: Available when BAS Type is set to BACnet-MSTP.</p>	<p>0 to 127 Default = 1</p>	<p>Installer</p>
<p>BACnet-MSTP BAUD RATE Select the BACnet-MSTP data communication rate. Higher data rates may restrict cable length and may require terminating resistors at the end of the RS-485 data bus. Conditions: Available when BAS Type is set to BACnet-MSTP.</p>	<p>9600, 19k2, 38k4, 57k6, 76k8, 115k Default = 9600</p>	<p>Installer</p>
<p>MODBUS ADDRESS Set the Modbus address. Each Modbus device must have a unique address. Conditions: Available when BAS Type is set to Modbus.</p>	<p>1 to 247 Default = 1</p>	<p>Installer</p>
<p>MODBUS DATA TYPE Select whether the Modbus network uses RTU or ASCII data frame format. Conditions: Available when BAS Type is set to Modbus.</p>	<p>RTU or ASCII Default = RTU</p>	<p>Installer</p>
<p>MODBUS BAUD RATE Select the Modbus data communication rate. Higher data rates may restrict cable length and may require terminating resistors at the end of the RS-485 data bus. Conditions: Available when BAS Type is set to Modbus.</p>	<p>2400, 9600, 19k2, 57k6, 115k Default = 19k2</p>	<p>Installer</p>
<p>MODBUS PARITY Select if the Modbus communication frame uses a parity bit. Conditions: Available when BAS Type is set to Modbus.</p>	<p>None, Even, Odd Default = Even</p>	<p>Installer</p>

Monitor Menu (1 of 3)

Description	Range	Access
<p>MELTING ENERGY Records the amount of energy used by the snow melting system since the counter was last reset. Conditions: Always available.</p>	<p><i>Hydronic</i> 0 to 999999 thm or GJ</p> <p><i>Electric</i> 0 to 999999 kWh</p>	<p>User Installer</p>
<p>MELTING HOURS Records the number of melting hours since the counter was last reset. Conditions: Always available.</p>	<p>0 to 999999 hours</p>	<p>User Installer</p>
<p>HEAT HOURS Records the number of hours the boiler fired or the electric cable heated since the counter was last reset. Conditions: Always available.</p>	<p>0 to 999999 hours</p>	<p>User Installer</p>
<p>HEAT CYCLES Records the number of cycles the boiler turned on or the electric cable heated since the counter was last reset. Conditions: Always available.</p>	<p>0 to 999999 cycles</p>	<p>Installer</p>
<p>SYSTEM PUMP Records the number of hours the system pump has operated since the counter was last reset. Conditions: Available when Application Mode is not set to Electric.</p>	<p>0 to 999999 hours</p>	<p>Installer</p>
<p>PRIMARY PUMP Records the number of hours the primary pump has operated since the counter was last reset. Conditions: Available when Application Mode is not set to Electric.</p>	<p>0 to 999999 hours</p>	<p>Installer</p>
<p>BOILER PUMP Records the number of hours the boiler pump has operated since the counter was last reset. Conditions: Available when Application Mode is set to Boiler or Boiler+Mix.</p>	<p>0 to 999999 hours</p>	<p>Installer</p>
<p>SLAB SENSOR 1 HIGH Records the highest measured slab 1 temperature since the counter was last reset. Conditions: Available when Snow/Ice Sensor 1 is set to In-slab or Slab Sensor 1 = On.</p>	<p>-58 to 167°F (-50.0 to 75.0°C)</p>	<p>Installer</p>
<p>SLAB SENSOR 1 LOW Records the lowest measured slab 1 temperature since the counter was last reset. Conditions: Available when Snow/Ice Sensor 1 is set to In-slab or Slab Sensor 1 = On.</p>	<p>-58 to 167°F (-50.0 to 75.0°C)</p>	<p>Installer</p>
<p>SLAB SENSOR 2 HIGH Records the highest measured slab 2 temperature since the counter was last reset. Conditions: Available when Snow/Ice Sensor 2 is set to In-slab or Slab Sensor 2 = On.</p>	<p>-58 to 167°F (-50.0 to 75.0°C)</p>	<p>Installer</p>
<p>SLAB SENSOR 2 LOW Records the lowest measured slab 2 temperature since the counter was last reset. Conditions: Available when Snow/Ice Sensor 2 is set to In-slab or Slab Sensor 2 = On.</p>	<p>-58 to 167°F (-50.0 to 75.0°C)</p>	<p>Installer</p>

Monitor Menu (2 of 3)

Description	Range	Access
OUTDOOR HIGH Records the highest measured outdoor air temperature since the counter was last reset. Conditions: Always available.	-67 to 149°F (-55.0 to 65.0°C)	Installer
OUTDOOR LOW Records the lowest measured outdoor air temperature since the counter was last reset. Conditions: Always available.	-67 to 149°F (-55.0 to 65.0°C)	Installer
BOILER SUPPLY HIGH Records the highest measured boiler supply temperature since the counter was last reset. Conditions: Available when Application Mode is set to Boiler or Boiler+Mix.	-31 to 266°F (-35.0 to 130.0°C)	Installer
BOILER SUPPLY LOW Records the lowest measured boiler supply temperature since the counter was last reset. Conditions: Available when Application Mode is set to Boiler or Boiler+Mix.	-31 to 266°F (-35.0 to 130.0°C)	Installer
BOILER RETURN HIGH Records the highest measured boiler return temperature since the counter was last reset. Conditions: Available when Application Mode is set to Boiler, Mixing, or Boiler+Mix.	-31 to 266°F (-35.0 to 130.0°C)	Installer
BOILER RETURN LOW Records the lowest measured boiler return temperature since the counter was last reset. Conditions: Available when Application Mode is set to Boiler, Mixing, or Boiler+Mix.	-31 to 266°F (-35.0 to 130.0°C)	Installer
SYSTEM SUPPLY HIGH Records the highest measured system supply temperature since the counter was last reset. Conditions: Available when Application Mode is set to PWM Zone, Mixing or Boiler+Mix.	-31 to 266°F (-35.0 to 130.0°C)	Installer
SYSTEM SUPPLY LOW Records the lowest measured system supply temperature since the counter was last reset. Conditions: Available when Application Mode is set to PWM Zone, Mixing or Boiler+Mix.	-31 to 266°F (-35.0 to 130.0°C)	Installer
SYSTEM RETURN HIGH Records the highest measured system return temperature since the counter was last reset. Conditions: Available when Application Mode is set to PWM Zone, Mixing or Boiler+Mix.	-31 to 266°F (-35.0 to 130.0°C)	Installer
SYSTEM RETURN LOW Records the lowest measured system return temperature since the counter was last reset. Conditions: Available when Application Mode is set to PWM Zone, Mixing or Boiler+Mix.	-31 to 266°F (-35.0 to 130.0°C)	Installer
PRESSURE HIGH Records the highest system pressure since the counter was last reset. Conditions: Available when 1) Application Mode is not set to Electric and 2) Pressure Sensor is set to On.	0 to 300 psi (0 to 2069 kPa)	Installer
PRESSURE LOW Records the lowest system pressure since the counter was last reset. Conditions: Available when 1) Application Mode is not set to Electric and 2) Pressure Sensor is set to On.	0 to 300 psi (0 to 2069 kPa)	Installer

Monitor Menu (3 of 3)

Description	Range	Access
FLOW RATE HIGH Records the highest system flow rate since the counter was last reset. Conditions: Available when 1) Application Mode is not set to Electric and 2) Flow Sensor is set to On.	0 to 1000 GPM (0 to 272 m ³ /h)	Installer
FLOW RATE LOW Records the lowest system flow rate since the counter was last reset. Conditions: Available when 1) Application Mode is not set to Electric and 2) Flow Sensor is set to On.	0 to 1000 GPM (0 to 272 m ³ /h)	Installer
RESET ALL? Resets all the counters in the monitor menu at once. Conditions: Always available.	N/A	Installer

Toolbox Menu		
Description	Range	Access
ERROR CODE The current error code is displayed. Conditions: Always available.	See Error Code Section	User Installer
ACCESS LEVEL Select the access level of the control. This determines which menus and items are available through the user interface. Conditions: Available when the DIP switch is set to Unlocked.	User or Installer Default = Installer	User Installer
TYPE 680 Product information. Product 680 tektra #: 107001 SW: J1243B SVN: 1054 Conditions: Always available.	J1243B Last letter indicates software version	User Installer
SCREEN BRIGHTNESS Select the screen brightness. Conditions: Always available.	0 to 100% Default = 75%	User Installer
TEMPERATURE UNITS Select Fahrenheit or Celsius temperature units. Conditions: Always available.	°F or °C Default = °F	User Installer
FLOW UNITS Select the units for measuring flow rates. Options include US gallons per minute (GPM), cubic meters per hour (m ³ /h) and liters per minute (LPM). Conditions: Available when Application Mode is not set to Electric.	GPM, m ³ /h, LPM Default = GPM	User Installer
ENERGY UNITS Select the units for measuring energy. Options include therms (thm), gigajoules (GJ), mega british thermal units (MBtu) and kilowatt-hours (kWh). Conditions: Available when Application Mode is not set to Electric.	thm, GJ, MBtu, or kWh Default = thm	User Installer
PRESSURE UNITS Select the units for measuring pressure. Options include pounds per square Inch (psi) or kilopascals (kPa). Conditions: Available when Application Mode is not set to Electric.	psi or kPa Default = psi	User Installer
LOAD DEFAULTS Select "Yes" to reload the factory defaults on the control. Conditions: Always available.	No or Yes	User Installer

Override Menu		
Description	Range	Access
<p>MANUAL OVERRIDE Manually override the normal automatic operation of the control to test the equipment or operate the system at the maximum temperature limits. Auto = Normal operation. Hand = Manual override of each relay output. Max Heat = Operate hydronic system at maximum heat. Test = Operate electric system for 10 minutes. Purge = Hydronic system purge operates pumps to help bleed air from the system. Conditions: Always available.</p>	Auto, Hand, Max Heat, Test, Purge, Off	User Installer
<p>SYSTEM PUMP Manually turn on the system pump during the HAND Manual Override. Conditions: Available when 1) Application Mode is set to PWM Zone, Boiler, Mixing or Boiler+Mix, and 2) Manual Override is set to Hand.</p>	Off or On Default = Off	Installer
<p>PRIMARY PUMP Manually turn on the primary pump during the HAND Manual Override. Conditions: Available when 1) Application Mode is set to PWM Zone, Boiler, Mixing or Boiler+Mix, and 2) Manual Override is set to Hand.</p>	Off or On Default = Off	Installer
<p>BOILER PUMP Manually turn on the boiler pump during the HAND Manual Override. Conditions: Available when 1) Application Mode is set to Boiler or Boiler+Mix, and 2) Manual Override is set to Hand.</p>	Off or On Default = Off	Installer
<p>BOILER MODULATION Manually set the modulating boiler firing rate during the HAND Manual Override. Conditions: Available when 1) Application Mode is set to Boiler or Boiler+Mix, 2) Manual Override is set to Hand, and 3) Boiler Type is set to Mod.</p>	0 to 100% Default = 0%	Installer
<p>BOILER STAGE 1 Manually turn on the boiler stage 1 during the HAND Manual Override. Conditions: Available when Manual Override is set to Hand.</p>	Off or On Default = Off	Installer
<p>BOILER STAGE 2 Manually turn on the boiler stage 2 during the HAND Manual Override. Conditions: Available when 1) Application Mode is set to Boiler or Boiler+Mix, 2) Manual Override is set to Hand, and 3) Boiler Type is set to Stage 2.</p>	Off or On Default = Off	Installer
<p>BOILER EMS Manually set the modulating boiler firing rate during the HAND Manual Override. Conditions: Available when 1) Application Mode is set to Boiler or Boiler+Mix, 2) Manual Override is set to Hand, and 3) Boiler Type is set to EMS.</p>	Off, 50 to 210 °F (10 to 99.0 °C) Default = Off	Installer
<p>MIX SYSTEM OUTPUT Manually set the mixing valve or injection mixing pump output during the HAND Manual Override. Conditions: Available when 1) Application Mode is set to Mixing or Boiler+Mix, and 2) Manual Override is set to Hand.</p>	0 to 100% Default = 0%	Installer
<p>HAND DURATION Select the amount of time that the HAND Override is in effect before returning to Automatic operation. Conditions: Available when 1) Application Mode is set to PWM Zone, Boiler, Mixing or Boiler+Mix, and 2) Manual Override is set to Hand.</p>	0:10 to 72:00 hours Default = 0:10 hour	Installer
<p>MAX HEAT DURATION Select the amount of time that Max Heat is in effect before returning to Automatic operation. Conditions: Available when 1) Application Mode is set to PWM Zone, Boiler, Mixing or Boiler+Mix, and 2) Manual Override is set to Max Heat.</p>	0:10 to 72:00 hours Default = 24:00 hour	Installer
<p>PURGE DURATION Select the amount of time that the Purge is in effect before returning to Automatic operation. Conditions: Available when 1) Application Mode is set to PWM Zone, Boiler, Mixing or Boiler+Mix, and 2) Manual Override is set to Purge.</p>	0:10 to 72:00 hours Default = 24:00 hour	Installer

Sequence of Operation

Snow Melting Overview

A snow melting system can offer a safe, convenient, and cost effective way of removing snow and ice from the snow melting slab and similar surfaces. Safety is increased by activating the snow melting system as soon as the snow falls rather than waiting for mechanical snow removal after snow has accumulated. This eliminates slip hazards and reduces the risk of injury by mechanized snow melting equipment, thereby reducing potential liability costs. The elimination of snow plow equipment and corrosive salts also reduces damage to the slab surface and to the environment. When controlled correctly, snow melting systems can be cost competitive compared to mechanical snow removal.

The snow melting control can operate in one of four different ways:

- Melt** Heats the slab to melt snow or ice
- Idle** Pre-heats the slab just below freezing to shorten the time required to melt snow
- Storm** Temporarily pre-heats the slab just below freezing to shorten the time required to melt snow
- Off** Snow melting system is off

The display shows the control operation in the home screen.

Melt Operation

The snow melting system operates the heating equipment to heat the slab from a cold start or from the idle or storm temperature to reach the melt temperature setting to melt snow or ice. Melt operation can be triggered automatically

using a snow/ice sensor, manually by pressing the Melt button on the display, or through the BACnet or Modbus protocol. The melt temperature setting affects calculated targets such as the slab target, boiler target and mix target.

Melt – Automatic Start and Stop

Automatic start and stop operation requires the installation of a Snow/Ice Sensor 090 (65' or 20 m cable) or 094 (208' or 63 m cable). The sensor is installed in-slab level with the melting surface. The control continually monitors the sensor for the presence of moisture and slab temperature conditions in which snow or ice may be present. When moisture is detected, the control shows "Sensor 1 Water Status Wet" in the Slab Status menu. When the sensor is dry the control shows "Sensor Water Status Dry". The control includes a Sensitivity setting in the Setpoints menu that allows the installer to adjust the amount of moisture required to start and stop the melting operation. In areas with low amounts of dust and/or air pollution, the sensitivity may need to be increased. The default sensitivity setting is Auto. This setting allows the control to automatically determine the best suitable sensitivity setting for the installation.

When moisture is detected and the slab and outdoor temperatures are at or below freezing, the control will automatically start the snow melting system. As the snow or ice melts and the slab dries off, the sensor also dries off at the same time. When the sensor is dry, the snow melt system automatically shuts off. If there are low spots on the slab surface that dry off slower than the sensor, additional melting run time can be included by adjusting the Additional Melt Time setting in the Setpoints menu.

If the snow melting system is manually stopped, the snow/ice sensor must fully dry before it is able to detect a new snow fall and automatically start the snow melting system.

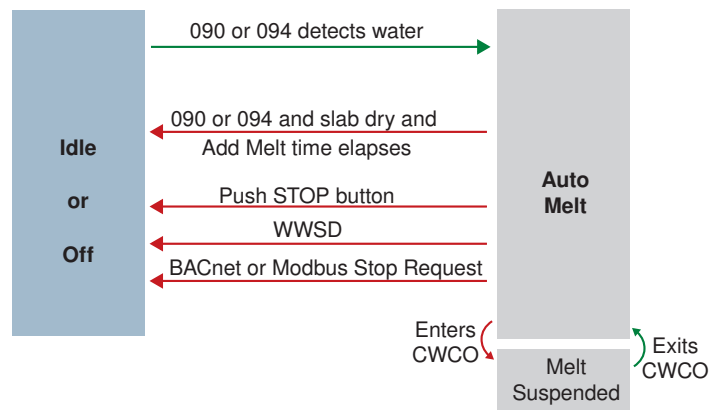

NOTICE

The slab temperature must reach the slab target in order for the system to shut off automatically. The capacity of the heat source must be sized to ensure melting as low as the cold weather cut off. In addition, the heat source maximum temperature setting

must be set to provide the full capacity of the heating appliance. For example, boiler aquastats should be set to 180°F (82°C). Failure to meet these requirements may result in the snow melting system not automatically shutting off when the slab is dry.

Melt – EconoMelt

When a Snow/Ice Sensor 090 or 094 is installed, the installer can choose to select to either automatically or manually start the snow melting system. Selecting EconoMelt to On allows snow removal using a snow plow or shovel. The remaining thin layer of snow or ice that mechanical snow removal methods are unable to remove can be melted using the manual start operation. The snow melting system stops when the sensor is dry. The factory default for EconoMelt is Off.

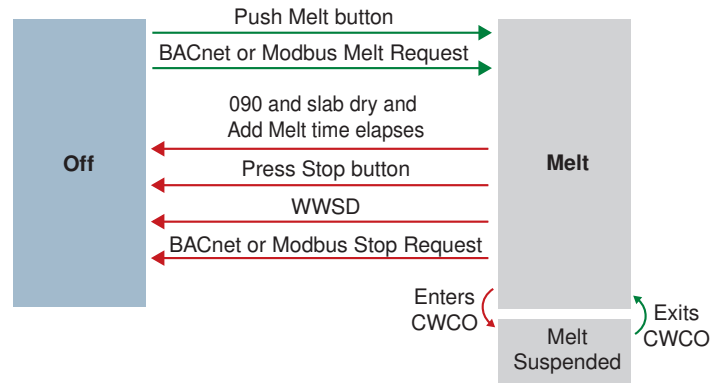

Additional Melting Time

A Snow/Ice Sensor 090 or 094 automatically shuts off the snow melting system when the water sensor is dry. Due to the construction of the slab and the layout of the heating pipe or electrical cable, there may be areas that do not melt completely. The Additional Melt Time setting in the Setpoints menu allows the installer to set addition melting time after the sensor is dry.

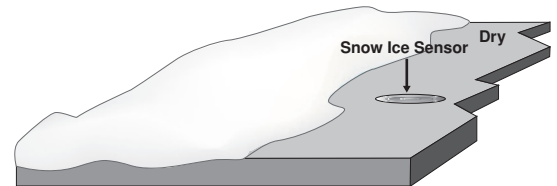

Melt – Automatic Start and Timed Stop

Automatic start with a timed stop operation requires the installation of a Snow Sensor 095. The sensor is aerial mounted on a pole near the melting surface. It is highly recommended to also install a Slab Sensor 072 (20' or 6 m cable) or 073 (40' or 12 m cable) in order to regulate the slab temperature and operate the snow melting system at the highest possible efficiency. The control continually monitors the snow sensor for the presence of moisture and slab temperature conditions in which snow or ice may be present. When moisture is detected, the control will show "Sensor Water Status Wet" in the Slab Status menu. When the sensor is dry the control will show "Sensor Water Status Dry". The control includes a Sensitivity setting in the Setpoints menu that allows the

installer to adjust the amount of moisture required to start and stop the melting operation. In areas with low amounts of dust and/or air pollution, the sensitivity may need to be increased. The default sensitivity setting is Auto. This setting allows the control to automatically determine the best suitable sensitivity setting for the installation.

When moisture is detected and both the slab and outdoor temperatures are below the Melting setting, the control automatically starts the snow melting system. The snow melting system operates to heat the slab to the slab target temperature and continues to operate until the time set by the Manual Melt Run Time in the Setpoints menu elapses.

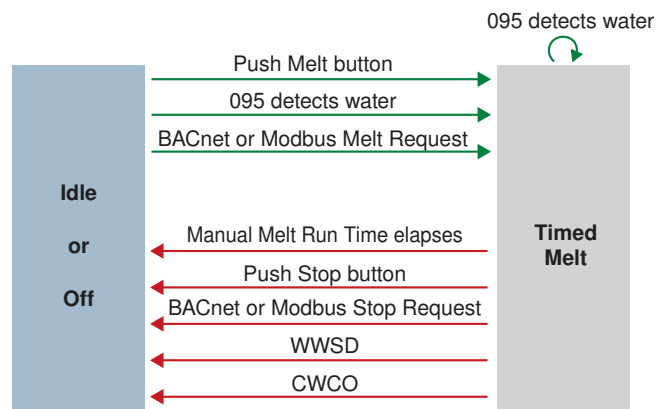

Tandem Snow/Ice Detection

The control allows any combination of two Snow/Ice sensors 090 or 094 or Snow Sensors 095 to be installed. This provides full redundancy and increases the snow detection area.

Both sensors are used to detect snow or ice and if either sensor is wet the snow melting zone starts melting. The control continues to operate until both sensors are dry. This allows snow or ice detection over a wider area. In the event of a sensor failure, the control continues to operate normally, giving building maintenance staff time to troubleshoot and replace the faulty sensor if necessary.

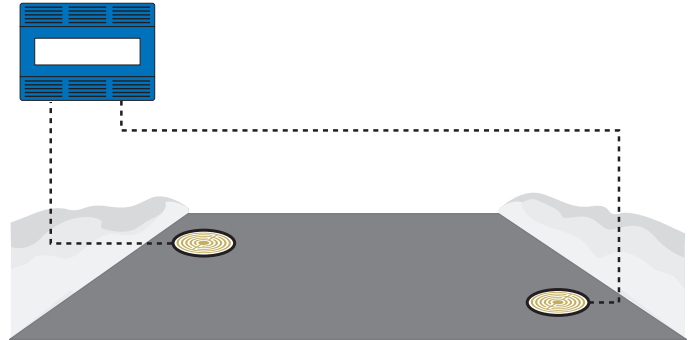

Melt – Manual Start and Timed Stop

The snow melting system can be started manually in one of two different methods:

- Touch the Melt button on the control display.
- The Melt/Stop Request parameter in the BACnet or Modbus communication protocol.

Once manually started, the snow melting system continues to operate until the time set by the Manual Melt Run Time setting in the Setpoints menu elapses.

If a manual start has been provided and a Snow/Ice Sensor detects water, the control changes from manual melt to automatic operation. The snow melting system will continue to operate until the sensor is dry and the Additional Melt Time elapses.

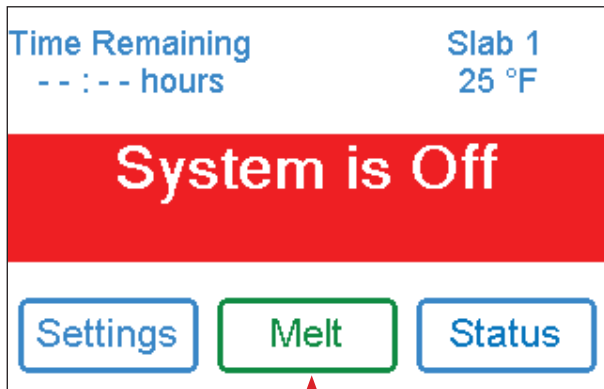

Press Melt button to start melting operation

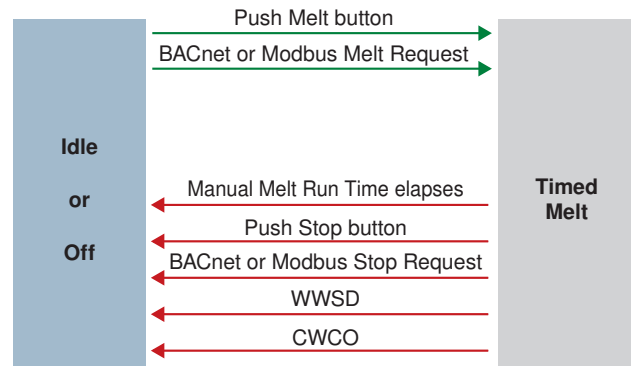

Idle Operation

When the snow melting system starts from a cold temperature, there may be a long time delay before the slab is warm enough to melt snow. This time delay allows snow to accumulate on the slab which is not acceptable in some commercial and institutional applications. To decrease the start-up time, the slab can be pre-heated to maintain a minimum temperature. This is known as the Idle temperature. Idling requires large energy consumption and is generally recommended for institutional and/or commercial installations where safety concerns are paramount. The display shows "System is Idling" when the control is in idle operation.

When designing a snow melting system, an engineer may specify the amount of allowed snow accumulation as the Snow-Free Area Ratio. There are three different levels. A Snow-Free Area Ratio of 1 is defined as a system that melts all snow as it falls with no allowed accumulation. This requires that the Idle temperature be set just below freezing. Examples of these types of applications include:

- Hospital emergency areas
- Helicopter landing pads
- Parking garage ramps

A Snow-Free Area Ratio of 0.5 is defined as a system with partial snow accumulation on the slab but not in all areas. These types of systems may also use Idling but usually set

at a temperature several degrees below freezing to reduce energy consumption. Applications may include:

- Steep residential driveways
- Commercial sidewalks
- Loading docks

A Snow-Free Area Ratio of 0 is defined as a system that allows snow accumulation. These systems operate the snow melting system from a cold start resulting in the lowest energy consumption costs and the longest times to start melting snow. In this case set the Idle to off. This is recommended for most residential applications such as:

- Flat residential driveways
- Patios
- Residential sidewalks

Some systems are designed for keeping a slab surface free of ice rather than free of snow. The most common applications include:

- Car wash bays and aprons
- Aircraft hanger aprons
- Turf conditioning on golf course greens

These systems require the use of Idling at or near freezing throughout the winter and may result in high energy consumption.

Storm Operation

For many applications it is too costly to Idle the snow melt system all winter. The Storm operation combines the benefits of a fast response time together with lower operating costs. The Storm operation does this by allowing the user to manually pre-heat the slab temporarily in preparation of a snowfall warning. In the event that snow falls and is detected by a Snow/Ice Sensor or a Snow Sensor or the system is manually started, the snow melt system heats the slab up to the melting temperature and completes a melting cycle. Should no snow fall during

the storm time period, the control exits Storm operation and returns to Off.

The Storm operation is set up by setting the Storm temperature and the Storm Run Time in the Setpoints menu. The Storm operation is activated by the Storm/Stop Request parameter in the BACnet or Modbus communication protocol.

Slab Temperature Control

Controlling the slab temperature is critical to minimizing the cost of snow melting. This requires that either a Snow/Ice Sensor 090 or 094 or a Slab Sensor 072 or 073 is installed. The Snow/Ice Sensor contains a built-in slab temperature sensor. While the control can operate without a slab sensor installed, operating costs are much higher.

The slab is operated using slab outdoor reset. As the outdoor temperature gets colder, the heat loss of the slab increases. In order to keep the slab surface at a constant temperature while operating, the inner core of the slab must be heated above the melt, idle or storm temperature setting. The amount that the slab inner core temperature is above the melt, idle or storm setting is proportional to the outdoor temperature. Since the slab sensor is installed below the surface of the slab, it is not measuring the true slab surface temperature but rather the inner core temperature. The control automatically compensates for this temperature difference. The Slab item in

the Status menu displays the actual measured temperature, so it is normal to view slab temperatures that exceed the melt, idle, or storm temperature settings.

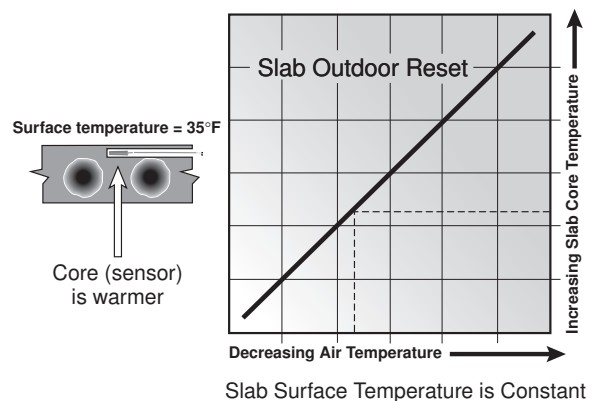

Slab Protection

In a hydronic snow melting system, the boiler or heating plant capacity may be much larger than the load of the snow melting zones. This can result in large temperature differentials between the supply water temperature and the slab creating large tensile stresses on the slab. Concrete is weak to tensile forces and when repeatedly exposed to tensile loads the concrete may crack. This may be prevented by selecting the Slab Protection setting in the System Setup menu to On. The control measures and limits the temperature differential between the supply water and the slab.

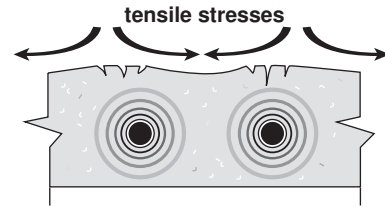

Warm Weather Shut Down

During warm weather, the slab is warm enough to naturally melt snow or ice. The control has a Warm Weather Shut Down (WWSD) setting in the Setpoints menu that prevents the control from entering Melt, Idle or Storm operation in order to conserve energy. The control shows, "System is Off – Warm Weather Shut Down" on the display when WWSD is in effect.

Automatic (Auto)

The control enters WWSD when both the slab temperature and the outdoor temperature exceed the Melting Setpoint temperature setting by more than 2°F (1°C).

Manual WWSD

The control enters WWSD when the outdoor air temperature exceeds the WWSD setting by 1°F (0.5°C) and when the slab temperature exceeds 34°F (1°C). The control exits WWSD when the outdoor air temperature falls 1°F (0.5°C) below the WWSD setting or if the slab temperature falls below 34°F (1°C). This allows the Melting Setpoint setting to be set higher than the WWSD. This is useful when high slab temperatures are required to melt the snow or ice. An example of this are installations using paving bricks on top of sand and concrete layers.

Cold Weather Cut Off

Maintaining the melting or idling setpoint temperature during extremely cold temperatures is not only expensive but may be impossible if the heat loss of the slab exceeds the input capacity of the heating plant or electric cable. The control turns the snow melting system off when the outdoor air temperature drops below the Cold Weather Cut Off (CWCO) temperature and the slab is below freezing. This is a safety and energy saving measure. The control shows, "System is

Off – Cold Weather Cut Off" on the display when CWCO is in effect. When the temperature reaches the CWCO setting in an actively melting system with an 090 or 094, melting is suspended until the outdoor temperature rises above the CWCO setting at which time melting is resumed. If an 090 or 094 is not installed, melting is stopped when CWCO is in effect and melting does not resume when the temperature rises above the CWCO setting.

Snow Melt Zones and Priority

Dividing a system into a number of snow melting zones and prioritizing the zone operation reduces the size requirements of the hydronic heating plant or the amperage of the electrical service panel. This results in lower initial capital cost of the snow melting system. The tradeoff is that some snow melt zones may not be able to melt as soon as the snow fall begins and the user must tolerate snow accumulation on the slab.

Prioritization of the snow melting zones can be accomplished using the BAS system. If two or more snow melting zones start automatically, the lower priority zone can be shut off using the Melt/Stop Request parameter in the BACnet or Modbus communication protocol. When the highest priority has finished melting, the BAS system can provide a Melt Request to manually start melting the zone. The zone will continue to operate until the snow/ice sensor is dry or the time has elapsed on the manual melt run timer.

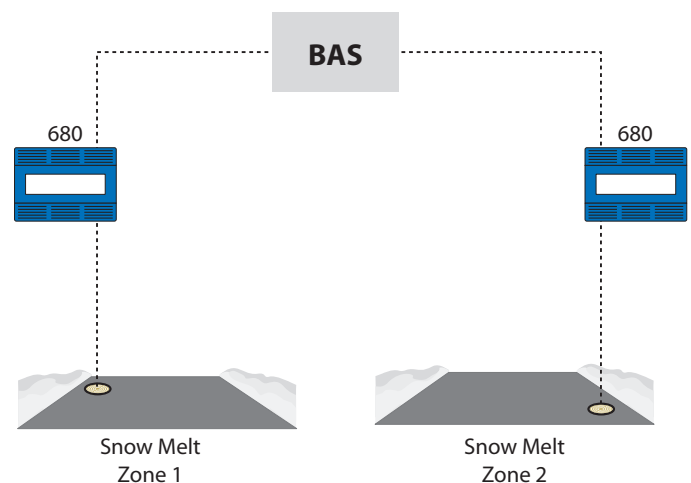

Application Modes

The snow melting control can operate either an electric or a hydronic snow melting system. A hydronic system can be categorized as boiler, mixing, boiler and mixing, or pulse width modulation zone operation. A dedicated boiler only provides heat for the snow melting system. A shared boiler provides heat for the snow melting system in addition to the space heating and/or a domestic hot water system. These choices affect which Application Mode is selected in the System Setup menu:

- | | |
|--------------|---------------------------------------|
| • PWM Zone | Pulse Width Modulation Zone Operation |
| • Boiler | Boiler Operation |
| • Mixing | Mixing Operation |
| • Boiler+Mix | Boiler and Mixing Operation |
| • Electric | Electrical Operation |

Electric Operation

The Application Mode should be set to Electric when operating an electric heating cable. The control operates the boiler stage 1 relay on a 20-minute pulse width modulation cycle. The boiler stage 1 relay in turn activates a line voltage electrical contactor to energize the electrical cable heater installed in the slab. The relay on time is determined by the calculated slab target and by the measured slab temperature reading. As the slab temperature reaches the slab target, the on-time per cycle of the relay is reduced to prevent the slab temperature from overshooting. If no slab sensor is installed the relay remains on 100% of the time until the Melt operation has completed. Idle and Storm operation are not available when a slab sensor is not installed. The electric operation requires the installation of an outdoor sensor. A slab sensor is highly recommended in order to reduce operating costs.

Relay operation:

- System pump — not used
- Primary pump — not used
- Boiler pump — not used
- Boiler stage 1 — cycles on/off using Pulse Width Modulation
- Boiler stage 2 — not used

Pulse Width Modulation Zone Operation

The Application Mode should be set to Pulse Width Modulation (PWM) Zone when the boiler or heat source is shared with the snow melting system and there is no mixing system. The snow melting system is considered to be part of a zone that includes space heating and domestic hot water.

The control operates the system pump to operate continuously during melt, idle and storm operation. The boiler stage 1 relay operates on a 20-minute pulse width modulation cycle. The relay on time is determined by the calculated slab target and by the measured slab temperature reading. As the slab temperature reaches the slab target, the on time per cycle of the relay is reduced to prevent the slab temperature from overshooting. If no slab sensor is installed the heat relay remains on 100% of the time until the Melt operation has completed. Idle and Storm operation are not available when a slab sensor is not installed. The PWM Zone operation requires the installation of an outdoor sensor. A slab sensor is highly recommended in order to reduce operating costs.

Relay operation:

- System pump — operates continuously during melt, idle or storm
- Primary pump — not used
- Boiler pump — not used
- Boiler stage 1 — cycles on/off using Pulse Width Modulation
- Boiler stage 2 — not used

Boiler Operation

The Application Mode should be set to Boiler when the snow melting system has a dedicated boiler or heat source and there is no mixing device. The boiler is piped primary-secondary to the snow melting loop, allowing the boiler to fire on and off while allowing continuous flow through the snow melting system loop. The control calculates a Boiler Target based upon the Slab Target, which in turn is based upon the measured outdoor temperature and the Melt, Idle or Storm temperature setting. The boiler is fired to maintain the Boiler Target at the Boiler Supply Sensor location. The control can operate a boiler in one of four different methods: modulating boiler, 1 stage, 2 stage and EMS. The Boiler Target is shown in the System Status menu. Settings for the boiler operation are located in the Boiler Setup menu.

1 Stage Boiler

The control turns the boiler stage 1 relay on or off to fire the boiler and maintain the Boiler Target temperature. The boiler supply temperature operates on a differential that is half above and half below the boiler target. The status of the boiler is shown in the System Status menu.

2 Stage Boiler

The control turns the boiler stage 1 and 2 relays on or off to fire a single boiler in order to maintain the Boiler Target temperature. The boiler supply temperature operates on a differential that is half above and half below the boiler target. The boiler staging is operated automatically using PID logic. The status of the boiler stages 1 and 2 is shown in the System Status menu.

Modulating Boiler

The control can operate a single hot-water modulating boiler using the modulating output and the boiler stage 1 contact. The control operates the boiler by first switching the boiler stage 1 contact to allow the modulating boiler to go through the ignition sequence. The boiler stage 1 contact may not be required on all modulating boilers. A 0-10 V (dc) or 4-20 mA analog signal is then used to modulate the boiler firing rate starting at 50% (5 V (dc) or 12 mA signal) for 30 seconds. After the 30-second delay has elapsed, the control will then allow the boiler to modulate down to the Boiler Minimum Modulation setting and hold it there for the Boiler Modulation Delay time setting. After the modulation delay has elapsed, the control uses PID logic to change the boiler firing rate signal in order to satisfy the boiler target temperature. When the firing rate signal is reduced down to the minimum modulating setting and the boiler supply temperature exceeds the boiler target by 1/2 of the differential, the control will shut off the boiler burner. The modulating signal output is shown by the Boiler Output in the System Status menu.

The Boiler Modulation Delay setting is determined by the boiler manufacturer. It is the amount of time that the burner must operate before the internal boiler control allows an external signal to operate the burner.

The Boiler Motor Speed sets the rate at which the modulating electrical signal can change. For most modulating boilers with an ECM fan, the boiler motor speed can be set to 30 seconds. For commercial boilers with a mod motor, set the boiler motor speed according to the time required by the mod motor to travel from the closed to open position.

EMS

When the boiler is required to operate, the control's boiler modulation output is adjusted to an appropriate analog signal corresponding to the boiler target temperature and then turns on the boiler stage 1 relay. The analog signal is proportional to the boiler target in a linear line defined by the EMS Signal Minimum, the EMS Low Temperature, and the EMS High Temperature settings.

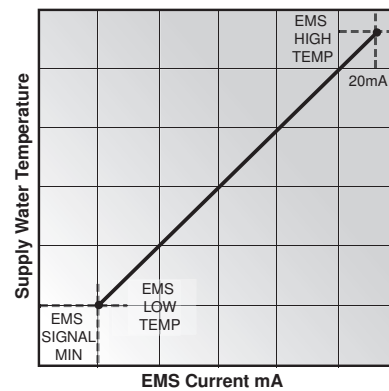
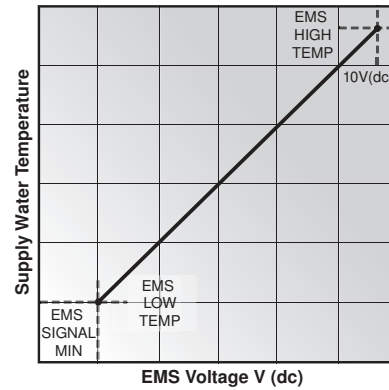

Relay operation:

System pump — operates continuously during melt, idle or storm

Primary pump — operates continuously during melt, idle or storm

Boiler pump — operates when the boiler is firing

Boiler stage 1 — cycles on/off based on boiler target

Boiler stage 2 — cycles on/off based on boiler target when using a two-stage boiler, otherwise off.

NOTICE

The boiler operator, or aquastat, remains in the burner circuit and acts as a secondary upper limit on the boiler temperature. It is recommended to set the boiler aquastat temperature at least to 180°F (82.0°C) in order to prevent short cycling of the burner.

Mixing Operation

The Application Mode should be set to Mixing when a mixing valve or a mixing injection pump is installed with a shared boiler plant. Four mixing options are available:

- Floating action mixing valve
- Variable-speed injection pump
- Analog mixing using 0-10 V (dc)
- Analog mixing using 4-20 mA

The control calculates the Slab Target temperature based on the outdoor air temperature and the Melting, Idling or Storm Setpoint. The control then determines the Mix System Target based on the Slab Target requirements. The Mix Maximum setting limits the upper temperature of the Mix System Target. The Mix System Target is shown in the System Status menu.

For design and sizing of the variable-speed injection mixing pump, please refer to the Essay E021.

Relay operation:

- System pump — operates continuously during melt, idle or storm

- Primary pump — operates continuously during melt, idle or storm
- Boiler pump — not used
- Boiler stage 1 — turns on when the valve is open or the injection mixing pump is operating.
- Boiler stage 2 — not used

If using Floating Action Mixing

- Floating action open — contact closes momentarily when pulsing actuator open
- Floating action closed — contact closes momentarily when pulsing actuator closed

If using Variable Speed Injection Mixing

- Injection Mixing Output — a variable speed signal is supplied to the pump

If using Analog Mixing

- Analog Mixing Output — a signal ranges between 0-10 V (dc) or 4 -20 mA

Boiler and Mixing Operation

The Application Mode should be set to Boiler+Mix when a mixing valve or a mixing injection pump is installed to regulate the supply water temperature to the snow melting system with a dedicated boiler plant. In this case, the control operates both the mixing device and the dedicated boiler at the same time.

The control calculates the Slab Target temperature based on the outdoor air temperature and the Melting, Idling or Storm Setpoint. The control then determines the Mix System Target based on the Slab Target requirements. The control then determines the required Boiler Target that is required to meet the Mix System Target. Refer to the Boiler and Mixing Operation sections for detailed information on the boiler and mixing operation.

Relay operation:

- System pump — operates continuously during melt, idle or storm
- Primary pump — operates continuously during melt, idle or storm

- Boiler pump — operates when the boiler is firing
- Boiler stage 1 — cycles on/off based on boiler target
- Boiler stage 2 — cycles on/off based on boiler target when using a two-stage boiler, otherwise off.

If using Floating Action Mixing

- Floating action open — contact closes momentarily when pulsing actuator open
- Floating action closed — contact closes momentarily when pulsing actuator closed

If using Variable Speed Injection Mixing

- Injection Mixing Output — a variable speed signal is supplied to the pump

If using Analog Mixing

- Analog Mixing Output — a signal ranges between 0-10 V (dc) or 4 -20 mA

Outdoor Sensor

The outdoor air temperature is required for all applications modes. The control has the option to measure an outdoor air sensor or the outdoor temperature can be provided through the

BACnet or Modbus communication system. This is selected by the Outdoor Sensor setting in the System Setup menu.

Exercising

In a hydronic snow melting system, the control operates the system, primary, boiler, variable speed injection mixing pump and mixing valve every 3 days to prevent pump and valve seizure.

Post Purge

The boiler or heat source is shut off and the snow melting system continues to operate for 20 seconds to post purge heat from the boiler to the load.

Troubleshooting

It is recommended to complete all wiring to ensure trouble free operation. Should an error occur, simply follow these steps:



1. **Find:** If the control shows the Warning Symbol (ⓘ) on the screen, it is indicating a problem on the system.
2. **Identify:** Press the Warning Symbol to view the error code.
3. **Solve:** Use the chart below to match the error code to the one on the control. Use the description to solve the problem.

Error Messages (1 of 4)
Description
<p>SETPOINTS MENU SAVE ERROR The control failed to read the Setpoints menu settings from memory and has reloaded the factory default settings. The control stops operation until all settings in the Setpoints menu are checked. To clear the error, set the access level to Installer and check all settings in the Setpoints menu.</p>
<p>SYSTEM SETUP MENU SAVE ERROR The control failed to read the System Setup menu settings from memory and has reloaded the factory default settings. The control stops operation until all settings in the System Setup menu are checked. To clear the error, set the access level to Installer and check all settings in the System Setup menu.</p>
<p>BOILER SETUP MENU SAVE ERROR The control failed to read the Boiler Setup menu settings from memory and has reloaded the factory default settings. The control stops operation until all settings in the Boiler Setup menu are checked. To clear the error, set the access level to Installer and check all settings in the Boiler Setup menu.</p>
<p>MIXING SETUP MENU SAVE ERROR The control failed to read the Mixing Setup menu settings from memory and has reloaded the factory default settings. The control stops operation until all settings in the Mixing Setup menu are checked. To clear the error, set the access level to Installer and check all settings in the Mixing Setup menu.</p>
<p>BAS MENU SAVE ERROR The control failed to read the BAS menu settings from memory and has reloaded the factory default settings. The control stops operation until all settings in the BAS menu are checked. To clear the error, set the access level to Installer and check all settings in the BAS menu.</p>
<p>LOW PRESSURE ALERT The system pressure has dropped below the Low Pressure Warning setting. This could indicate that the snow melting system has a leak. Fix any leaks and ensure that the glycol solution has not been diluted with water. To clear the error, press the Cancel button while viewing the warning message.</p>
<p>MAX MELT DAYS ERROR The control has operated in melting for the time set by Maximum Melt Days setting located in the System Setup menu. This error is usually created when there is a mechanical system failure resulting in the snow melt slab not heating correctly. Clear the error message by touching the Cancel button while viewing the error message. Use the Manual Override menu to manually check that each component of the mechanical system is operating correctly. If necessary, change the Maximum Melt Days setting to a longer time period or to Off.</p>
<p>OUTDOOR SENSOR OPEN CIRCUIT ERROR Due to an open circuit, the control is unable to read the Outdoor Sensor 070 on terminals 14 and 15. This error also occurs when the BAS system has failed to communicate the outdoor temperature parameter. The control continues to operate and assumes an outdoor temperature of 32°F (0°C). Energy saving features such as Warm Weather Shut Down (WWSD) and Cold Weather Cut Off (CWCO) are disabled. Check the outdoor sensor wire for open circuits according to the sensor installation manual. It may be necessary to replace the outdoor sensor. Once the error has been corrected, the error message automatically clears.</p>
<p>OUTDOOR SENSOR SHORT CIRCUIT ERROR Due to a short circuit, the control is unable to read the Outdoor Sensor 070 on terminals 14 and 15. The control continues to operate and assumes an outdoor temperature of 32°F (0°C). Energy saving features such as Warm Weather Shut Down (WWSD) and Cold Weather Cut Off (CWCO) are disabled. Check the outdoor sensor wire for short circuits according to the sensor installation manual. It may be necessary to replace the outdoor sensor. Once the error has been corrected, the error message automatically clears.</p>

Error Messages (2 of 4)

Description

SYSTEM SUPPLY SENSOR OPEN CIRCUIT ERROR

Due to an open circuit, the control is unable to read the System Supply Sensor 082 on terminals 11 and 12. The control stops operation and does not provide any heat.

Check the system supply sensor wire for open circuits according to the sensor installation manual. It may be necessary to replace the system supply sensor. Once the error has been corrected, the error message automatically clears.

SYSTEM SUPPLY SENSOR SHORT CIRCUIT ERROR

Due to a short circuit, the control is unable to read the System Supply Sensor 082 on terminals 11 and 12. The control stops operation and does not provide any heat.

Check the system supply sensor wire for short circuits according to the sensor installation manual. It may be necessary to replace the system supply sensor. Once the error has been corrected, the error message automatically clears.

SYSTEM RETURN SENSOR OPEN CIRCUIT ERROR

Due to an open circuit, the control is unable to read the System Return Sensor 082 on terminals 11 and 13. The control continues normal operation but does not accumulate any energy usage.

Check the system return sensor wire for open circuits according to the sensor installation manual. It may be necessary to replace the system return sensor. Once the error has been corrected, the error message automatically clears.

SYSTEM RETURN SENSOR SHORT CIRCUIT ERROR

Due to a short circuit, the control is unable to read the System Return Sensor 082 on terminals 11 and 13. The control continues normal operation but does not accumulate any energy usage.

Check the system return sensor wire for short circuits according to the sensor installation manual. It may be necessary to replace the system return sensor. Once the error has been corrected, the error message automatically clears.

BOILER SUPPLY SENSOR OPEN CIRCUIT ERROR

Due to an open circuit, the control is unable to read the Boiler Supply Sensor 082 on terminals 8 and 9. When application mode is set to boiler or boiler+mix the control stops operation. In all other application modes, the control continues to heat the snow melting system but does not control the boiler operating temperature.

Check the boiler supply sensor wire for open circuits according to the sensor installation manual. It may be necessary to replace the boiler supply sensor. Once the error has been corrected, the error message automatically clears.

BOILER SUPPLY SENSOR SHORT CIRCUIT ERROR

Due to a short circuit, the control is unable to read the Boiler Supply Sensor 082 on terminals 8 and 9. When application mode is set to boiler or boiler+mix the control stops operation. In all other application modes, the control continues to heat the snow melting system but does not control the boiler operating temperature.

Check the boiler supply sensor wire for short circuits according to the sensor installation manual. It may be necessary to replace the boiler supply sensor. Once the error has been corrected, the error message automatically clears.

BOILER RETURN SENSOR OPEN CIRCUIT ERROR

Due to an open circuit, the control is unable to read the Boiler Return Sensor 082 on terminals 8 and 10. The control continues to heat the snow melting system but does not provide boiler protection.

Check the boiler return sensor wire for open circuits according to the sensor installation manual. It may be necessary to replace the boiler return sensor. Once the error has been corrected, the error message automatically clears.

BOILER RETURN SENSOR SHORT CIRCUIT ERROR

Due to a short circuit, the control is unable to read the Boiler Return Sensor 082 on terminals 8 and 10. The control continues to heat the snow melting system but does not provide boiler protection.

Check the boiler return sensor wire for short circuits according to the sensor installation manual. It may be necessary to replace the boiler return sensor. Once the error has been corrected, the error message automatically clears.

SLAB 1 SENSOR OPEN CIRCUIT ERROR

Due to an open circuit, the control is unable to read the Slab Sensor 072 or 073 on terminals 19 and 20. The control continues normal operation if slab sensor 2 is installed; otherwise, Idling and Storm are disabled and energy saving features such as Warm Weather Shut Down (WWSD) and Cold Weather Cut Off (CWCO) are operated using the outdoor temperature only.

Check the slab sensor 1 wire for open circuits according to the sensor installation manual. It may be necessary to replace the slab sensor. Once the error has been corrected, the error message automatically clears.

If the slab sensor 1 has been intentionally removed, set the slab sensor 1 setting in the System Setup menu to Off.

SLAB 1 SENSOR SHORT CIRCUIT ERROR

Due to a short circuit, the control is unable to read the Slab Sensor 072 or 073 on terminals 19 and 20. The control continues normal operation if slab sensor 2 is installed; otherwise, Idling and Storm are disabled and energy saving features such as Warm Weather Shut Down (WWSD) and Cold Weather Cut Off (CWCO) are operated using the outdoor temperature only.

Check the slab sensor 1 wire for short circuits according to the sensor installation manual. It may be necessary to replace the slab sensor. Once the error has been corrected, the error message automatically clears.

Error Messages (3 of 4)

Description

SNOW SENSOR 1 YELLOW WIRE OPEN CIRCUIT ERROR

Due to an open circuit, the control is unable to read the yellow wire connected to the Snow/Ice Sensor 090 or 094, or the Snow Sensor 095 on terminals 20 and 22. The control continues normal operation if snow/ice sensor 2 is installed; otherwise, the control can no longer automatically detect snow or ice, but manual start of the snow melting system is still available.

Check the snow/ice sensor or snow sensor yellow and black wires and any wire splices for open circuits according to the sensor installation manual. It may be necessary to replace the sensor. Once the error has been corrected, the error message automatically clears.

SNOW SENSOR 1 BLUE WIRE OPEN CIRCUIT ERROR

Due to an open circuit, the control is unable to read the blue wire connected to the Snow/Ice Sensor 090 or 094, or the Snow Sensor 095 on terminals 20 and 21. The control continues normal operation if snow/ice sensor 2 is installed; otherwise, the control can no longer automatically detect snow or ice, but manual start of the snow melting system is still available.

Check the snow/ice sensor 1 or snow sensor 1 blue and black wires and any wire splices for open circuits according to the sensor installation manual. It may be necessary to replace the sensor. Once the error has been corrected, the error message automatically clears.

SNOW SENSOR 1 BLUE WIRE SHORT CIRCUIT ERROR

Due to a short circuit, the control is unable to read the blue wire connected to the Snow/Ice Sensor 090 or 094, or the Snow Sensor 095 on terminals 20 and 21. The control continues normal operation if snow/ice sensor 2 is installed; otherwise, the control can no longer automatically detect snow or ice, but manual start of the snow melting system is still available.

First check the snow/ice sensor 1 or snow sensor 1 for dirt or debris. The ring structure of the sensor may need cleaning with hot soapy water and a nylon brush. Rinse with water. Second, check the snow/ice sensor 1 or snow sensor 1 blue and black wires and any wire splices for short circuits according to the sensor installation manual. It may be necessary to replace the sensor. Once the error has been corrected, the error message automatically clears.

SNOW SENSOR 1 BROWN WIRE OPEN CIRCUIT ERROR

Due to an open circuit, the control is unable to read the brown wire connected to the Snow/Ice Sensor 090 or 094 on terminals 19 and 20. The control continues normal operation if snow/ice sensor 2 is installed; otherwise, Idling and Storm is disabled and energy saving features such as Warm Weather Shut Down (WWSD) and Cold Weather Cut Off (CWCO) are operated using the outdoor temperature only.

Check the snow/ice sensor 1 brown and black wires for open circuits according to the sensor installation manual. It may be necessary to replace the sensor. Once the error has been corrected, the error message automatically clears.

SNOW SENSOR 1 BROWN WIRE SHORT CIRCUIT ERROR

Due to a short circuit, the control is unable to read the brown wire connected to the Snow/Ice Sensor 090 or 094 on terminals 19 and 20. The control continues normal operation if snow/ice sensor 2 is installed; otherwise, Idling and Storm is disabled and energy saving features such as Warm Weather Shut Down (WWSD) and Cold Weather Cut Off (CWCO) are operated using the outdoor temperature only.

Check the snow/ice sensor 1 brown and black wires for short circuits according to the sensor installation manual. It may be necessary to replace the sensor. Once the error has been corrected, the error message automatically clears.

SNOW/ICE SENSOR 1 ERROR

The control is unable to properly detect the Snow/Ice Sensor 090 or 094 on terminals 19, 20, 21, 22 and 23. The control continues normal operation if snow/ice sensor 2 is installed; otherwise, the control can no longer automatically detect snow or ice, but manual start of the snow melting system is still available.

Check the snow/ice sensor 1 brown, yellow, red and black wires according to the sensor installation manual. It is important to check any cable splices for loose wiring connections. It may be necessary to replace the sensor. Once the error has been corrected, the error message automatically clears.

SNOW SENSOR 1 ERROR

The control is unable to properly detect the Snow Sensor 095 on terminals 20, 21, 22 and 23. The control continues normal operation if snow sensor 2 is installed; otherwise, the control can no longer automatically detect snow but manual start of the snow melting system is still available.

Check the snow sensor 1 yellow, red and black wires according to the sensor installation manual. It may be necessary to replace the sensor. Once the error has been corrected, the error message automatically clears.

SLAB SENSOR 2 OPEN CIRCUIT ERROR

Due to an open circuit, the control is unable to read the Slab Sensor 072 or 073 on terminals 24 and 25. The control continues normal operation if slab sensor 1 is installed; otherwise, Idling and Storm are disabled and energy saving features such as Warm Weather Shut Down (WWSD) and Cold Weather Cut Off (CWCO) are operated using the outdoor temperature only.

Check the slab sensor 2 wire for open circuits according to the sensor installation manual. It may be necessary to replace the slab sensor. Once the error has been corrected, the error message automatically clears.

If the slab sensor 2 has been intentionally removed, set the slab sensor 2 setting in the System Setup menu to Off.

Error Messages (4 of 4)

Description

SLAB SENSOR 2 SHORT CIRCUIT ERROR

Due to a short circuit, the control is unable to read the Slab Sensor 072 or 073 on terminals 24 and 25. The control continues normal operation if slab sensor 1 is installed; otherwise, Idling and Storm are disabled and energy saving features such as Warm Weather Shut Down (WWSD) and Cold Weather Cut Off (CWCO) are operated using the outdoor temperature only.

Check the slab sensor 2 wire for short circuits according to the sensor installation manual. It may be necessary to replace the slab sensor. Once the error has been corrected, the error message automatically clears.

SNOW SENSOR 2 YELLOW WIRE OPEN CIRCUIT ERROR

Due to an open circuit, the control is unable to read the yellow wire connected to the Snow/Ice Sensor 090 or 094 or the Snow Sensor 095 on terminals 25 and 27. The control continues normal operation if snow/ice sensor 1 is installed; otherwise, the control can no longer automatically detect snow or ice, but manual start of the snow melting system is still available.

Check the snow/ice sensor 2 or snow sensor 2 yellow and black wires and any wire splices for open circuits according to the sensor installation manual. It may be necessary to replace the sensor. Once the error has been corrected, the error message automatically clears.

SNOW SENSOR 2 BLUE WIRE OPEN CIRCUIT ERROR

Due to an open circuit, the control is unable to read the blue wire connected to the Snow/Ice Sensor 090 or 094 or the Snow Sensor 095 on terminals 25 and 26. The control continues normal operation if snow/ice sensor 1 is installed; otherwise, the control can no longer automatically detect snow or ice, but manual start of the snow melting system is still available.

Check the snow/ice sensor 2 or snow sensor 2 blue and black wires and any wire splices for open circuits according to the sensor installation manual. It may be necessary to replace the sensor. Once the error has been corrected, the error message automatically clears.

SNOW SENSOR 2 BLUE WIRE SHORT CIRCUIT ERROR

Due to a short circuit, the control is unable to read the blue wire connected to the Snow/Ice Sensor 090 or 094 or the Snow Sensor 095 on terminals 25 and 26. The control continues normal operation if snow/ice sensor 1 is installed; otherwise, the control can no longer automatically detect snow or ice, but manual start of the snow melting system is still available.

First check the snow/ice sensor 2 or snow sensor 2 for dirt or debris. The ring structure of the sensor may need cleaning with hot soapy water and a nylon brush. Rinse with water. Secondly, check the snow/ice sensor 2 or snow sensor 2 blue and black wires and any wire splices for short circuits according to the sensor installation manual. It may be necessary to replace the sensor. Once the error has been corrected, the error message automatically clears.

SNOW SENSOR 2 BROWN WIRE OPEN CIRCUIT ERROR

Due to an open circuit, the control is unable to read the brown wire connected to the Snow/Ice Sensor 090 or 094 on terminals 24 and 25. The control continues normal operation if snow/ice sensor 1 is installed; otherwise, Idling and Storm is disabled and energy saving features such as Warm Weather Shut Down (WWSD) and Cold Weather Cut Off (CWCO) are operated using the outdoor temperature only.

Check the snow/ice sensor 2 brown and black wires for open circuits according to the sensor installation manual. It may be necessary to replace the sensor. Once the error has been corrected, the error message automatically clears.

SNOW SENSOR 2 BROWN WIRE SHORT CIRCUIT ERROR

Due to a short circuit, the control is unable to read the brown wire connected to the Snow/Ice Sensor 090 or 094 on terminals 24 and 25. The control continues normal operation if snow/ice sensor 1 is installed; otherwise, Idling and Storm is disabled and energy saving features such as Warm Weather Shut Down (WWSD) and Cold Weather Cut Off (CWCO) are operated using the outdoor temperature only.

Check the snow/ice sensor 2 brown and black wires for short circuits according to the sensor installation manual. It may be necessary to replace the sensor. Once the error has been corrected, the error message automatically clears.

SNOW/ICE SENSOR 2 ERROR

The control is unable to properly detect the Snow/Ice Sensor 090 or 094 on terminals 24, 25, 26, 27 and 28. The control continues normal operation if snow/ice sensor 1 is installed; otherwise, the control can no longer automatically detect snow or ice, but manual start of the snow melting system is still available.

Check the snow/ice sensor 2 brown, yellow, red and black wires according to the sensor installation manual. It is important to check any cable splices for loose wiring connections. It may be necessary to replace the sensor. Once the error has been corrected, the error message automatically clears.

SNOW SENSOR 2 ERROR

The control is unable to properly detect the Snow Sensor 095 on terminals 25, 26, 27 and 28. The control continues normal operation if snow sensor 1 is installed; otherwise, the control can no longer automatically detect snow, but manual start of the snow melting system is still available.

Check the snow sensor 2 yellow, red and black wires according to the sensor installation manual. It may be necessary to replace the sensor. Once the error has been corrected, the error message automatically clears.

Frequently Asked Questions

Symptom	Look For...	Corrective Action
Touchscreen is off	Power to control	Use electrical meter to measure 115 V (ac) voltage on input power L and N terminals.
System pump always on	Display shows Idle	Idle operation requires that the system pump operate continuously while below the melting temperature setting.
Blue short	Dirt or salt on snow/ice sensor	The snow/ice sensor requires regular cleaning. Avoid using road salt on the snow melting slab.
Slab is above melt temperature	Slab Target	The slab is heated to the slab target.
System running with no snow	System is Idling	Idling heats the slab when the temperature falls below the Idle temperature.
	System is Melting	During cold weather cut off (CWCO), the system is shut off. If it shuts off during a melt cycle, the system resumes melting once the outdoor temperature is above CWCO.
	Remaining Run Time	System manually started.
	Slab and Slab Target	The slab must reach the slab target temperature in order for the system to shut off. Lower the cold weather cut off (CWCO) or increase the boiler aquastat setting.
Snow on slab but system did not start	System is Off	System has been manually stopped and the automatic snow/ice sensor never dried, thereby preventing the system from automatically starting.

WARNING: This product contains chemicals known to the State of California to cause cancer and birth defects or other reproductive harm. For more information: watts.com/prop65

Technical Data

Snow Melting Control 680 BAS, Boiler & Mixing	
Literature	680_A, 680_B, 680_C, 680_D
Control	Microprocessor control. This is not a safety (limit) control.
Packaged weight	6.5 lb. (2950 g)
Dimensions	8-1/16" H x 11-1/8" W x 2-15/16" D (204 x 282 x 74 mm)
Display	3-1/4", color touchscreen, 320 x 205 pixels
Enclosure	PC+ABS plastic with steel conduit connection walls, NEMA type 1
Approvals	CSA C US, meets class B: ICES & FCC Part 15
Ambient conditions	Indoor use only, 32 to 122°F (0 to 50°C), < 90% RH non-condensing
Power supply	115 V (ac) ±10%, 60 Hz, 43 VA standby, 320 VA max
Primary, system pump relays	230 V (ac), 10 A, 1/2 hp
Boiler pump relay	230 V (ac), 5 A, 1/3 hp
Boiler stage relays	230 V (ac), 5 A
Boiler modulating output	0-10 V (dc) 500 Ω min impedance / 4-20 mA 1 kΩ max impedance
Injection mixing pump	230 V (ac), 2.4 A
Floating mixing output	230 V (ac), 5 A
Analog mixing output	0-10 V (dc) 500 Ω min impedance / 4-20 mA 1 kΩ max impedance
Flow sensor	4-20 mA, 20 V (dc) power supply by control
Pressure sensor	0.5-4.5 V (dc) ratio metric, 10 kΩ min load, 5 V (dc) power supply by control
Communications	BACnet IP, BACnet MSTP, Modbus MSTP
Sensors	NTC thermistor, 10 kΩ @ 77°F (25°C ±0.2°C) β=3892
–Included	Outdoor Sensor 070 and 3 of Universal Sensor 082
–Optional	tekmar type: 072, 073, 082, 090, 094, 095

Limited Warranty and Product Return Procedure

Limited Warranty *The liability of tekmar under this warranty is limited. The Purchaser, by taking receipt of any tekmar product ("Product"), acknowledges the terms of the Limited Warranty in effect at the time of such Product sale and acknowledges that it has read and understands same.*

The tekmar Limited Warranty to the Purchaser on the Products sold hereunder is a manufacturer's pass-through warranty which the Purchaser is authorized to pass through to its customers. Under the Limited Warranty, each tekmar Product is warranted against defects in workmanship and materials if the Product is installed and used in compliance with tekmar's instructions, ordinary wear and tear excepted. The pass-through warranty period is for a period of twenty-four (24) months from the production date if the Product is not installed during that period, or twelve (12) months from the documented date of installation if installed within twenty-four (24) months from the production date.

The liability of tekmar under the Limited Warranty shall be limited to, at tekmar's sole discretion: the cost of parts and labor provided by tekmar to repair defects in materials and/or workmanship of the defective product; or to the exchange of the defective product for a warranty replacement product; or to the granting of credit limited to the original cost of the defective product, and such repair, exchange or credit shall be the sole remedy available from tekmar, and, without limiting the foregoing in any way, tekmar is not responsible, in contract, tort or strict product liability, for any other losses, costs, expenses, inconveniences, or damages, whether direct, indirect, special, secondary, incidental or consequential, arising from ownership or use of the product, or from defects in workmanship or materials, including any liability for fundamental breach of contract.

The pass-through Limited Warranty applies only to those defective Products returned to tekmar during the warranty period. This Limited Warranty does not cover the cost of the parts or labor to remove or transport the defective Product, or to reinstall the repaired or replacement Product, all such costs and expenses being subject to Purchaser's agreement and warranty with its customers.

Any representations or warranties about the Products made by Purchaser to its customers which are different from or in excess of the tekmar Limited Warranty are the Purchaser's sole responsibility and obligation. Purchaser shall indemnify and hold tekmar harmless from and against any and all claims, liabilities and damages of any kind or nature which arise out of or are related to any such representations or warranties by Purchaser to its customers.

The pass-through Limited Warranty does not apply if the returned Product has been damaged by negligence by persons other than tekmar, accident, fire, Act of God, abuse or misuse; or has been damaged by modifications, alterations or attachments made subsequent to purchase which have not been authorized by tekmar; or if the Product was not installed in compliance with tekmar's instructions and/or the local codes and ordinances; or if due to defective installation of the Product; or if the Product was not used in compliance with tekmar's instructions.

THIS WARRANTY IS IN LIEU OF ALL OTHER WARRANTIES, EXPRESS OR IMPLIED, WHICH THE GOVERNING LAW ALLOWS PARTIES TO CONTRACTUALLY EXCLUDE, INCLUDING, WITHOUT LIMITATION, IMPLIED WARRANTIES OF MERCHANTABILITY AND FITNESS FOR A PARTICULAR PURPOSE, DURABILITY OR DESCRIPTION OF THE PRODUCT, ITS NON-INFRINGEMENT OF ANY RELEVANT PATENTS OR TRADEMARKS, AND ITS COMPLIANCE WITH OR NON-VIOLATION OF ANY APPLICABLE ENVIRONMENTAL, HEALTH OR SAFETY LEGISLATION; THE TERM OF ANY OTHER WARRANTY NOT HEREBY CONTRACTUALLY EXCLUDED IS LIMITED SUCH THAT IT SHALL NOT EXTEND BEYOND TWENTY-FOUR (24) MONTHS FROM THE PRODUCTION DATE, TO THE EXTENT THAT SUCH LIMITATION IS ALLOWED BY THE GOVERNING LAW.

Product Warranty Return Procedure All Products that are believed to have defects in workmanship or materials must be returned, together with a written description of the defect, to the tekmar Representative assigned to the territory in which such Product is located. If tekmar receives an inquiry from someone other than a tekmar Representative, including an inquiry from Purchaser (if not a tekmar Representative) or Purchaser's customers, regarding a potential warranty claim, tekmar's sole obligation shall be to provide the address and other contact information regarding the appropriate Representative.



tekmar Control Systems Ltd., A Watts Water Technologies Company. Head Office: 5100 Silver Star Road, Vernon, B.C. Canada V1B 3K4, 250-545-7749, Fax. 250-545-0650 Web Site: tekmarControls.com