

# tekmar® - Wiring Brochure

## Mixing Expansion Module 444



**W444**

12/08

- |   |  |  |   |  |  |
|---|--|--|---|--|--|
| <b>1 Information Brochure</b><br>Choose controls to match application | <b>2 Application Brochure</b><br>Design your mechanical applications | <b>3 Rough-in Wiring</b><br>Rough-in wiring instructions | <b>4 Wiring Brochure</b><br>Wiring and installation of specific control | <b>5 Data Brochure</b><br>Control settings and sequence of operation | <b>6 Job Record</b><br>Record settings & wiring details for future reference |
|---|--|--|---|--|--|

### Overview



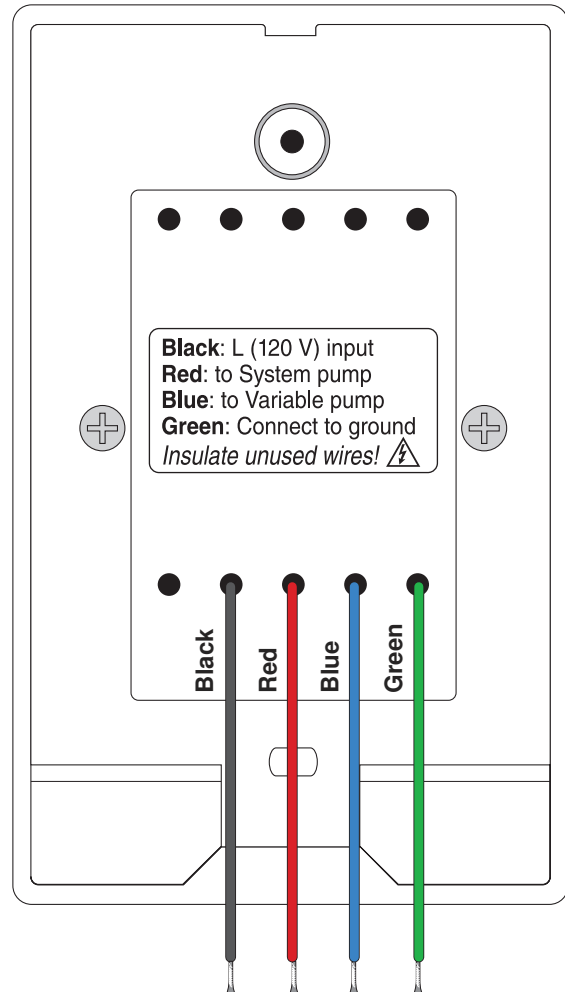
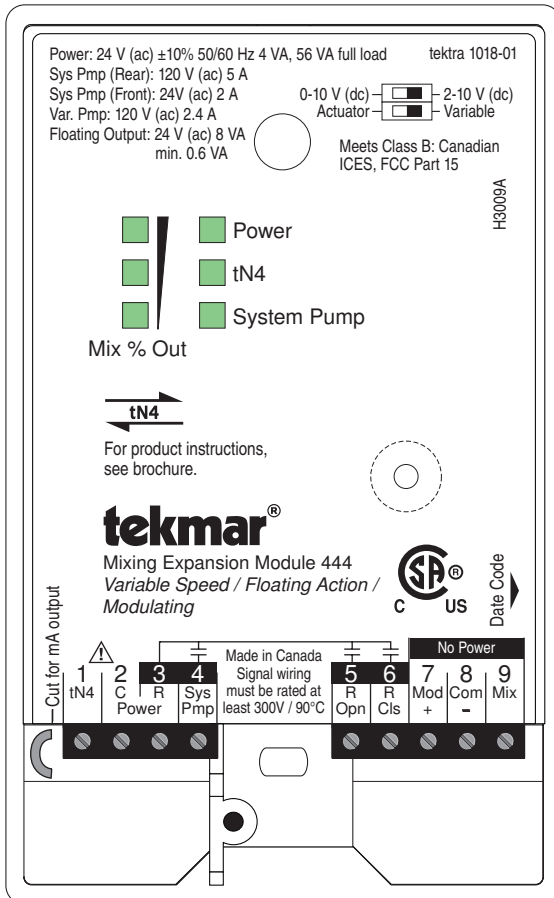



The Mixing Expansion Module 444 must be wired to a tekmarNet®4 System Control and cannot operate as a stand alone control. The 444 operates either a variable speed injection pump, a floating action actuator motor, or a mixing device that accepts an analog 0-10 V (dc), 2-10 V (dc), 0-20 mA, or 4-20 mA signal.



## Table of Contents

Wiring Symbols & Definitions .....	2	Troubleshooting the Wiring .....	10
Module Installation .....	3	Testing the Module .....	10-11
Electrical Drawings .....	3-7	Technical Data .....	12
Wiring the Module .....	8-9		

## Wiring Symbols

	Dry contact switch. Operates a device.		Black reverse lettering denotes an internally powered output.
	Powered switch. 24-115 V (ac) power, switched output to valve, pump, etc.		<b>Do not apply power</b> to these terminals. Serious control damage will result.
	tekmarNet®4		Earth ground

## Definitions

The following defined terms and symbols are used throughout this manual to bring attention to the presence of hazards of various risk levels, or to important information concerning the life of the product.



– Caution: Refer to accompanying documents



– Caution: Refer to accompanying documents

**INSTALLATION  
CATEGORY II**

– Local level appliances

### **Caution**

Improper installation and operation of this control could result in damage to the equipment and possibly even personal injury or death. It is your responsibility to ensure that this control is safely installed according to all applicable codes and standards. This electronic control is not intended for uses as a primary limit control. Other controls that are intended and certified as safety limits must be placed into

the control circuit. Do not attempt to service the control. Refer to qualified personnel for servicing. Apart from any field replaceable fuse(s) there are no user serviceable parts. Attempting to do so voids warranty and could result in damage to the equipment and possibly even personal injury or death.

## Module Installation

### To Install the 444:

1. Grasp the front cover by the fingertip grips on the top and bottom of the enclosure and pull the front cover off.
2. Remove the wiring cover screw.
3. The mounting holes in the enclosure accept #6 screws.

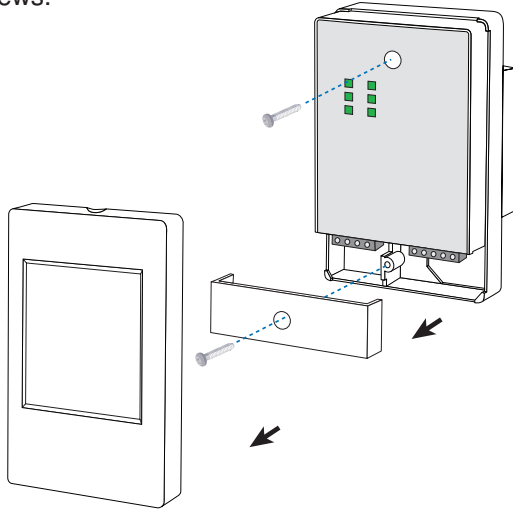

#### ⚠ 4. The module can be installed two ways:

- On a larger electrical box (Figure 1) where the extra low voltage (ELV) wiring enters the module from inside the electrical box. The ELV wiring must be rated at least 300 V and minimum 194°F (90°C) and have over current protection to 10 A maximum.

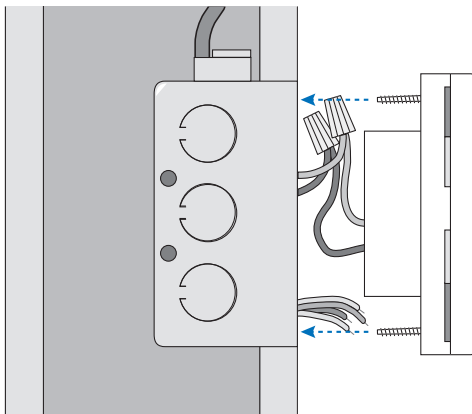

Figure 1

- On a smaller electrical box (Figure 2) where the extra low voltage (ELV) wiring enters the module from outside the electrical box. The ELV wiring must be used only on CEC/NEC Class 2 circuits per the CEC/NEC.

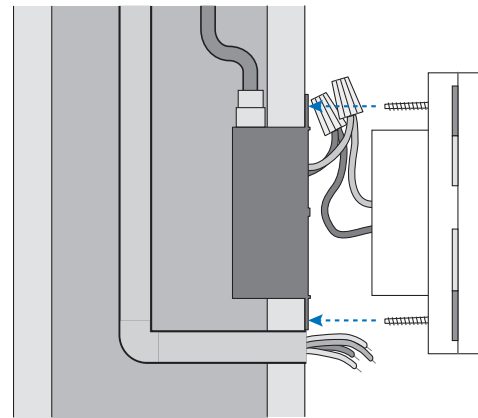

Figure 2

- #### ⚠ 5. The electrical box must have a minimum depth of 1.75".
- Rough-in wiring is made to the electrical box using standard wiring practices.
  - All wires must be rated at least 300 V.
  - High voltage wires should be 14 AWG conductors.
  - Low voltage wires should be 18 AWG conductors.
  - Strip all wiring to a length of 3/8 inch or 10 mm for all terminals.
  - High voltage wiring connections are made inside the electrical box directly to the wires exiting the back of the module.
  - All unused high voltage wires located on the back of the module require a wire nut to insulate the wire.
  - An approved circuit breaker or power disconnect that de-energizes the high voltage wiring should be located near the module, and marked as the 120 V (ac) power disconnect for this module.
  - 120 V (ac) high voltage power supply circuits must be protected by 15 A maximum overcurrent protection.
  - Only qualified personnel should attempt installation of the module.
6. To reassemble the enclosure, first replace the wiring chamber cover and then push the front cover onto the enclosure until it snaps into place.

## Electrical Drawings

⚠ The electrical drawing examples on the following pages show the 444 in common applications. Choose the drawing that most accurately depicts the components in your system and use that drawing as a guide to aid in wiring your system.

These are only concept drawings, not engineered drawings. They are not intended to describe a complete system nor any particular system. It is up to the system designer to

determine the necessary components for and configuration of the particular system being designed including additional equipment, isolation relays (for loads greater than the controls specified output ratings) and any safety devices which in the judgment of the designer are appropriate in order to properly size, configure and design that system and to ensure compliance with building and safety code requirements.

**Description:**

The Mixing Expansion Module 444 communicates to a tN4 System Control and operates the speed of a variable speed injection pump. The 444 can also operate a mix system pump from either the front or from the back of the module.

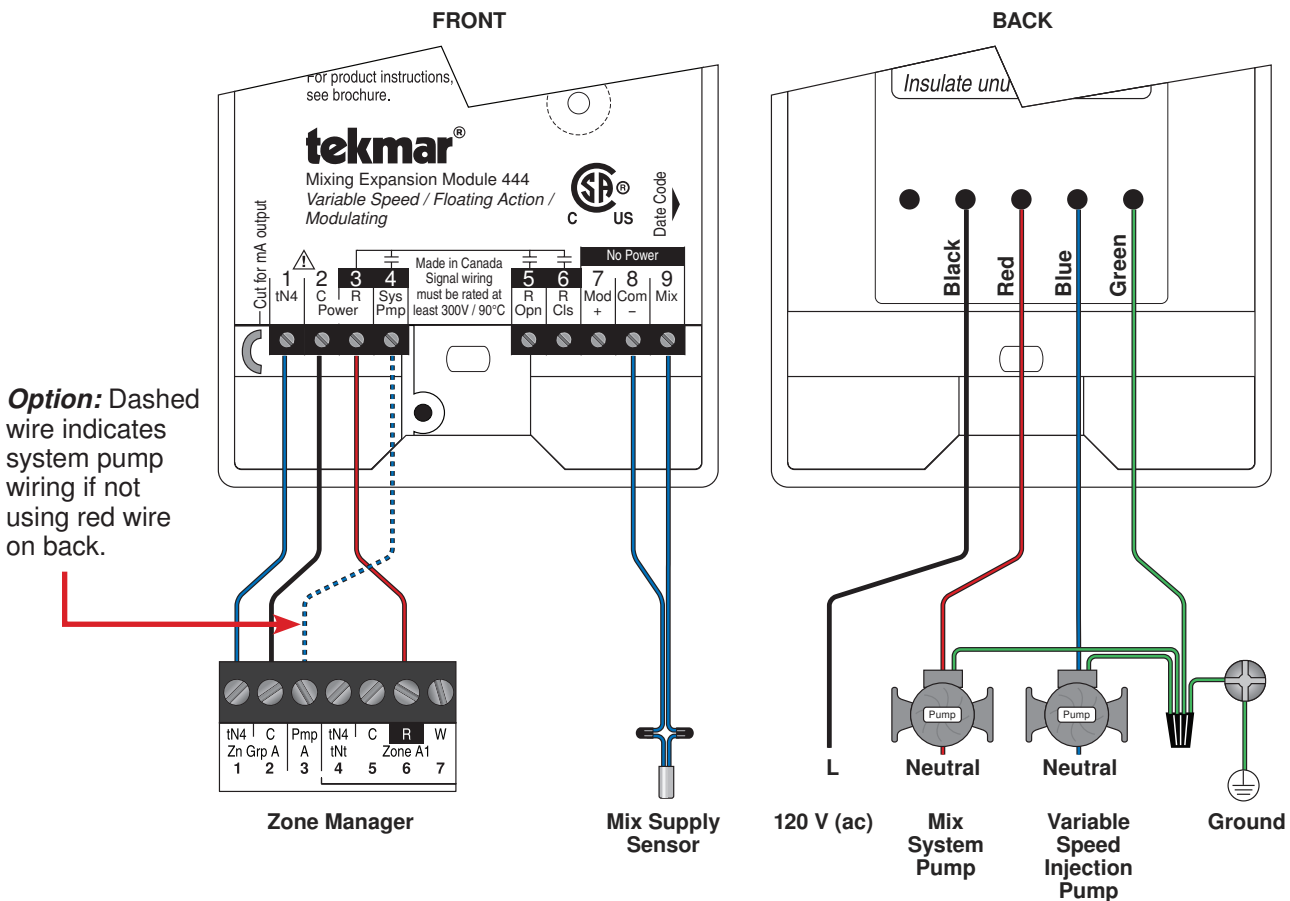
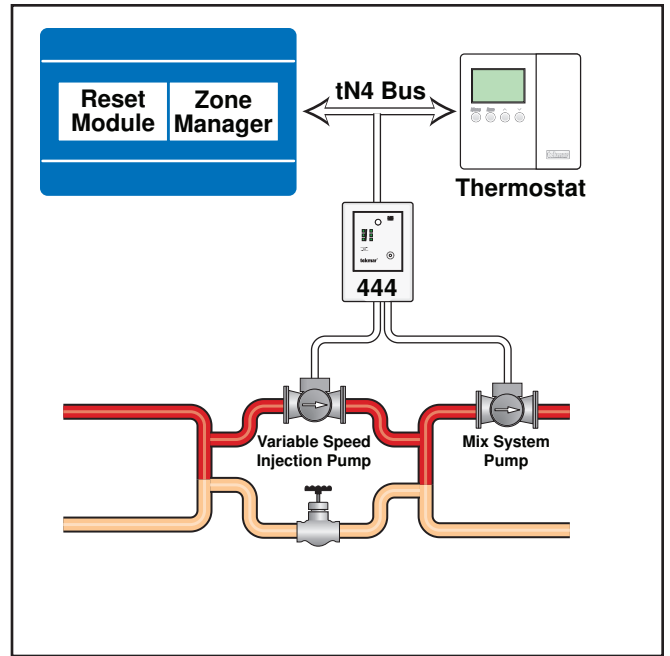

**Description:**

The Mixing Expansion Module 444 communicates to a tN4 System Control and operates a floating actuating motor to change the position of a mixing valve. The 444 can also operate a mix system pump from either the front or the back of the module.

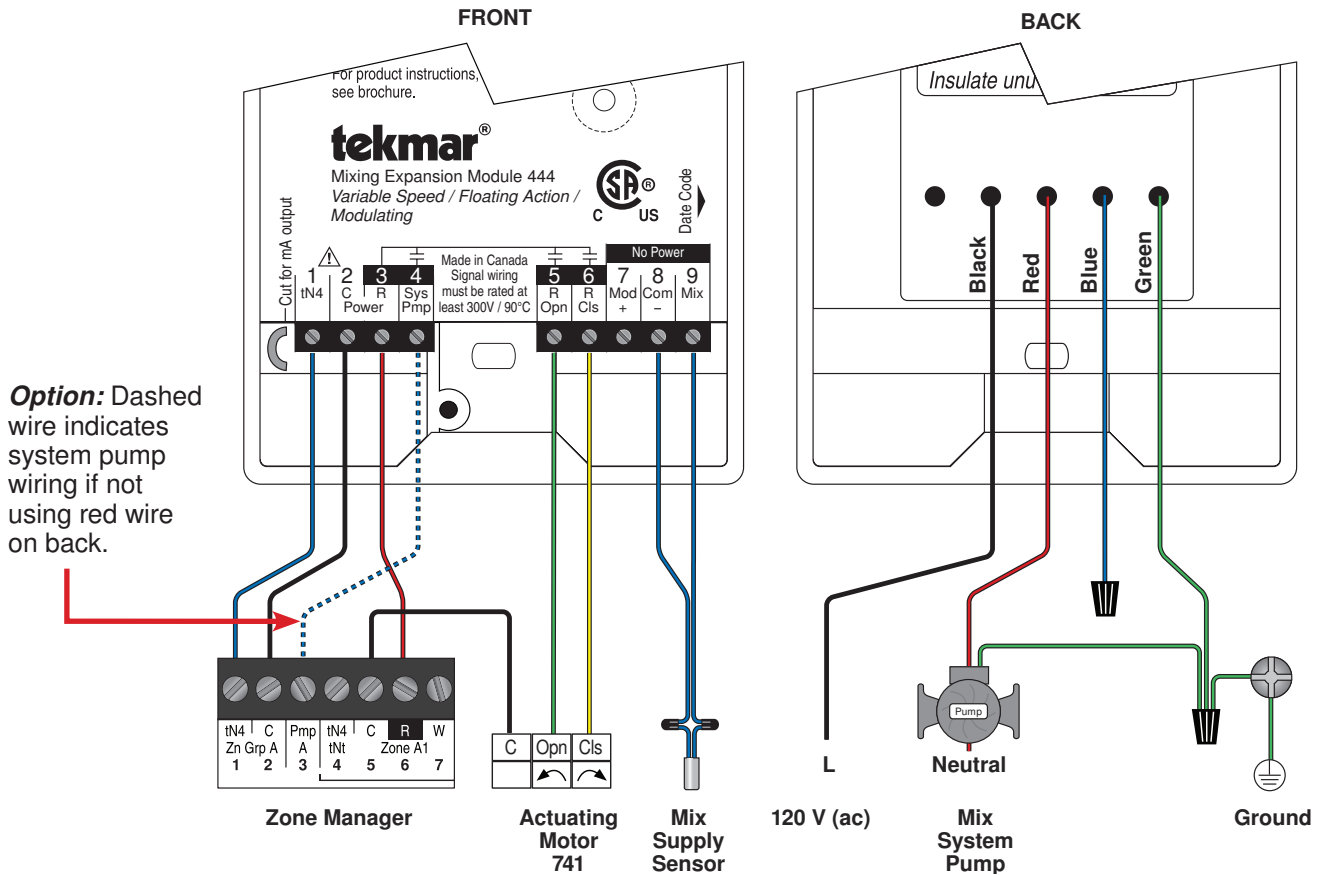
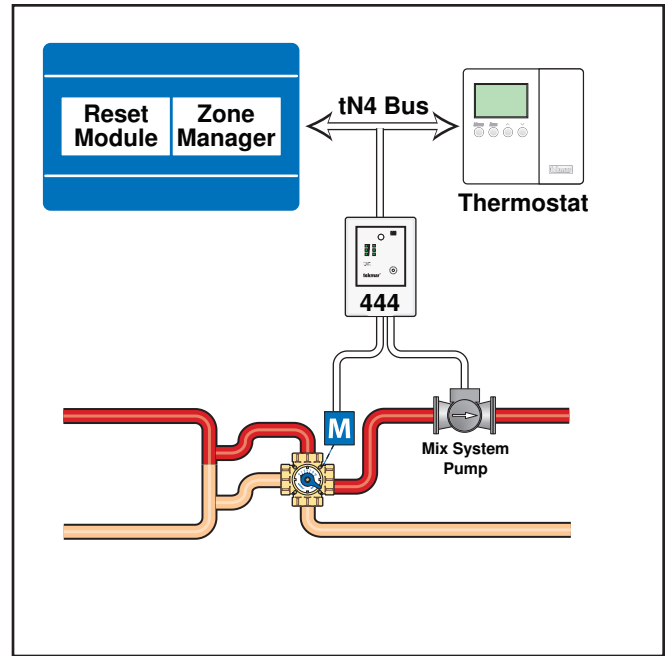

**Description:**

The Mixing Expansion Module 444 communicates to a tN4 System Control and operates an analog 0-10 V (dc), 2-10 V (dc), 0-20 mA, or 4-20 mA signal.

The analog signal can be used to operate an actuating motor, a variable frequency drive (VFD), or a modulating steam to hot water valve.

The 444 can also operate a mix system pump from either the front or the back of the module.

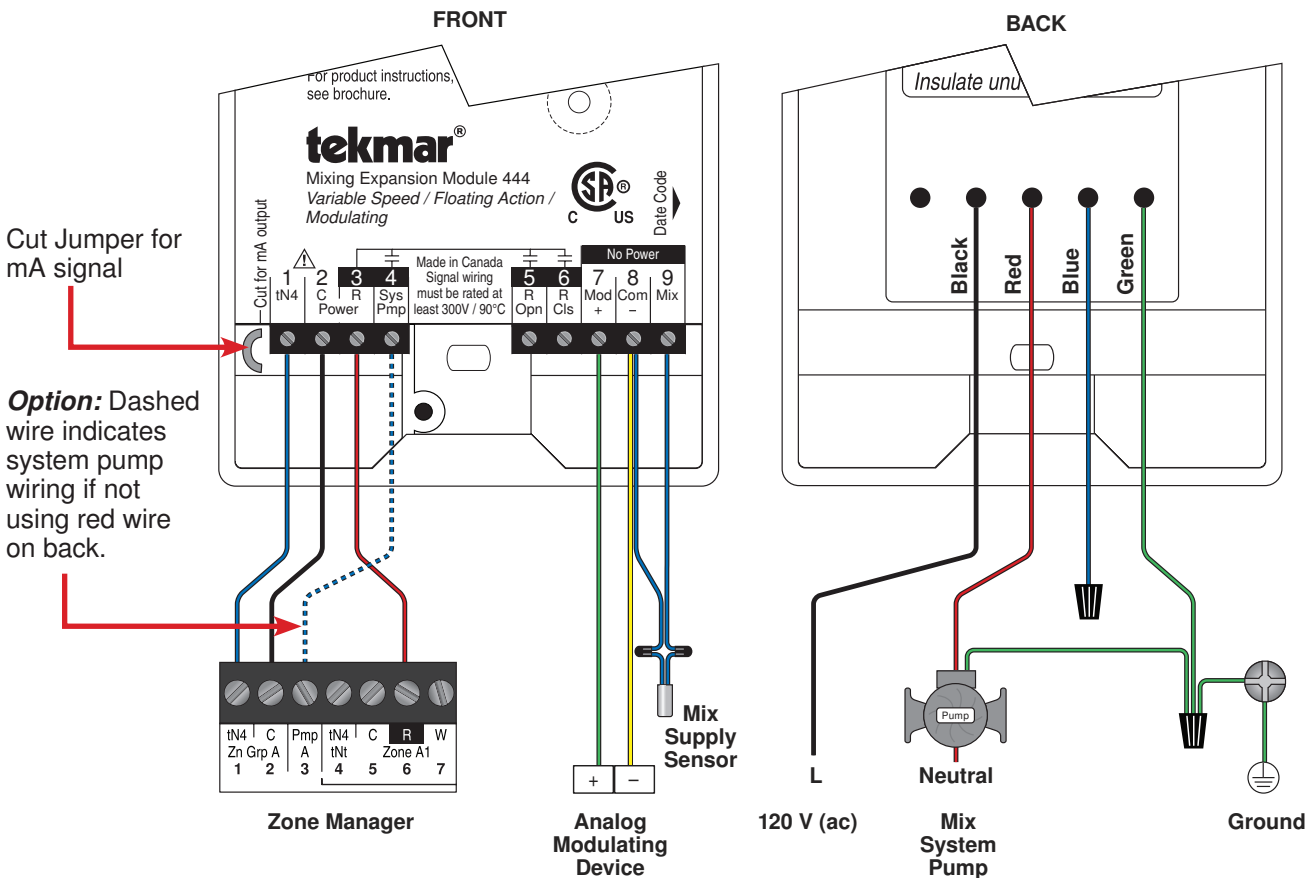
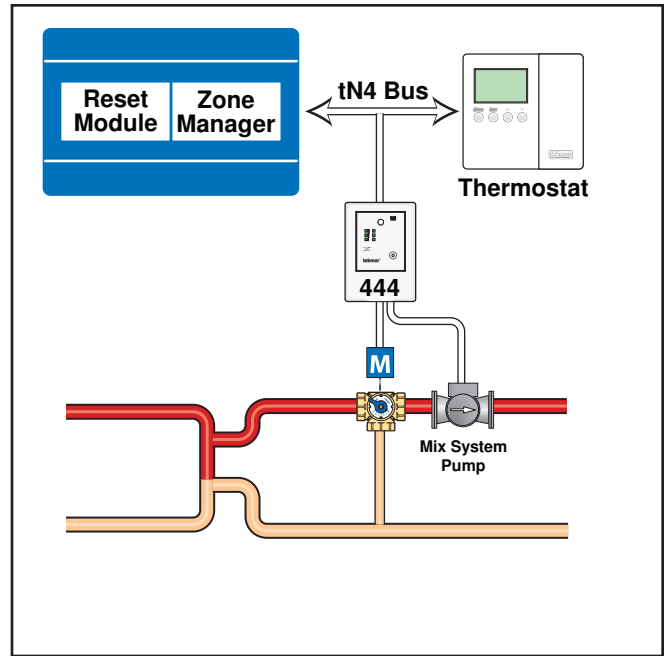

**Description:**

The Mixing Expansion Module 444 communicates to a tN4 System Control and operates a floating actuating motor to change the position of a 4-way valve.

The 444 can be powered using an external 24 V (ac) transformer. However, the tN4 and C terminals must connect to a tN4 mix bus.

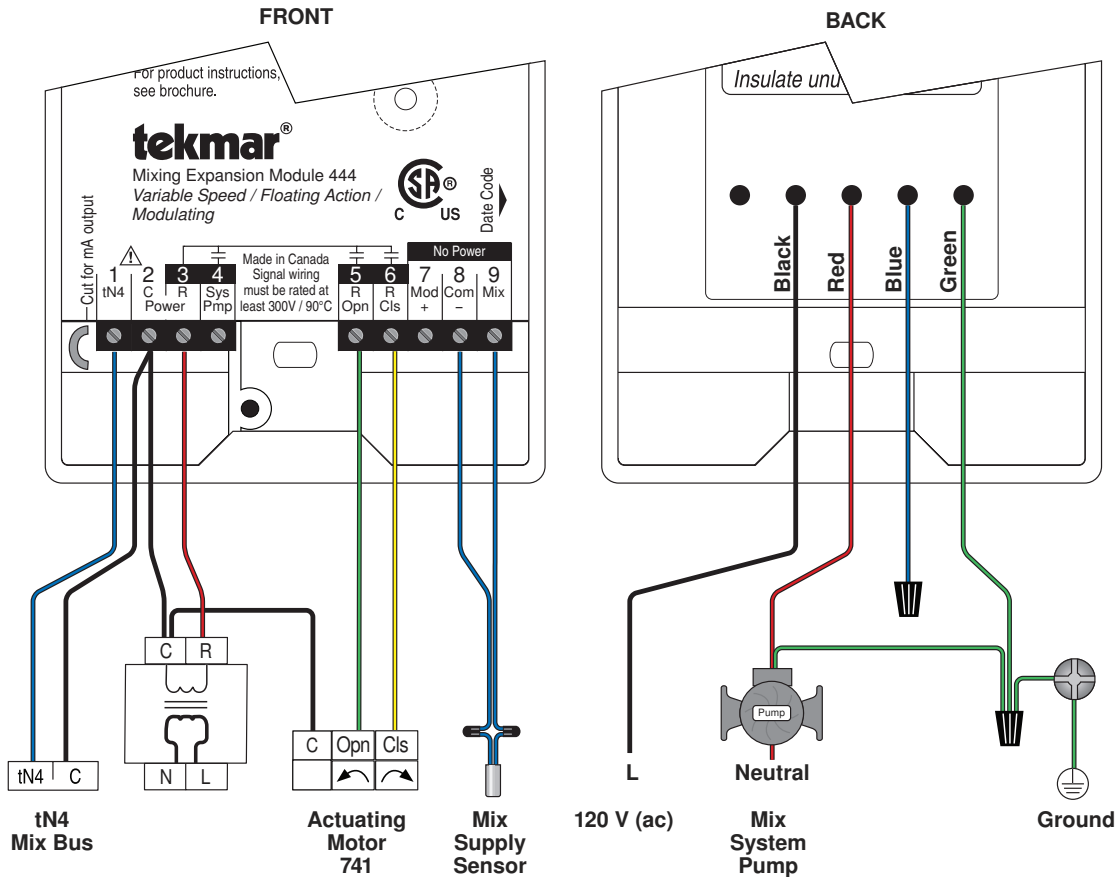
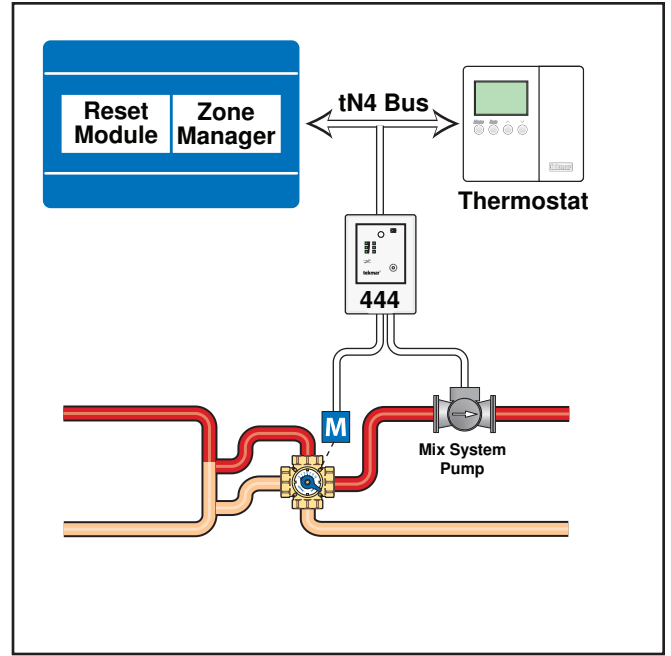

⚠ The following section explains how to wire individual devices to the Mixing Expansion Module 444. For step by step wiring refer to the terminal number on the right of the page.

- Before wiring ensure all power is turned off and take all necessary precautions.
- Strip all wiring to a length of 3/8 in. or 10 mm for all terminals.
- Refer to the current and voltage ratings at the back of this brochure before connecting devices to this control.

**⚠ Wiring a Variable Speed Injection Pump**

*Back of Module*

- Connect 120 V (ac) to the Black wire on the back of the module.
- Connect the injection pump to the Blue wire on the back of the module.
- Connect the ground to the Green wire on the back of the control.
- Connect the neutral wire to the injection pump.

**Note:** Ensure that a wire nut is installed on the Red wire (if not used) on the back of the module.

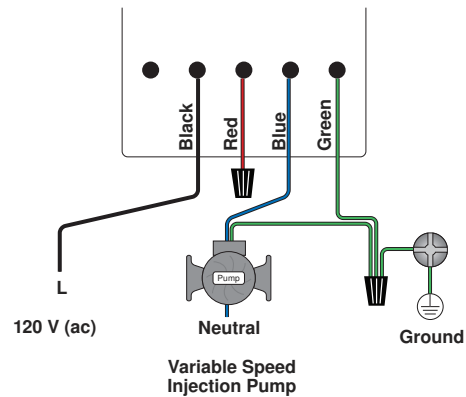

**⚠ Wiring a Floating Action Actuator (Mixing Valve)**

*Terminals 2, 5, 6*

- Identify the direction of rotation for the mixing valve, either clockwise or counterclockwise.
- Connect Open (terminal 5) to the actuator motor terminal that opens the valve.
- Connect Close (terminal 6) to the actuator motor terminal that closes the valve.
- Connect C from the actuator motor to a C terminal on the Zone Manager or transformer.

**Note:** Ensure that a wire nut is installed on the Blue wire on the back of the module.

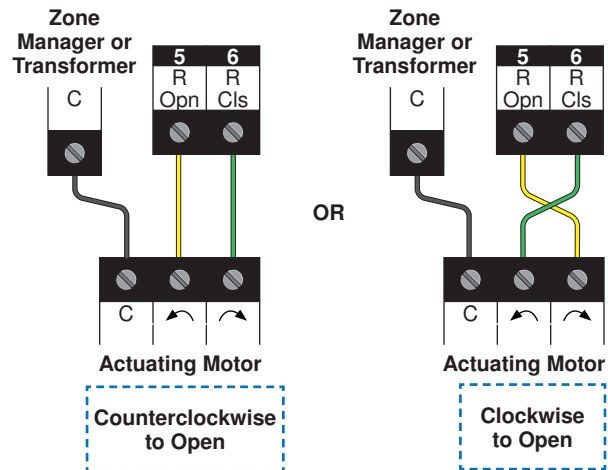

**⚠ Wiring an Analog Modulating Signal**

*Terminals 7, 8*

**(0-10 V (dc), 2-10 V (dc), 0-20 mA, 4-20 mA)**

- A 3rd party device that accepts a 0-10 V (dc), 2-10 V (dc), 0-20 mA, 4-20 mA analog modulating signal can be operated.
- For mA analog signals, cut the jumper wire located in the lower left hand corner of the wiring area.
- Connect the + on terminal 7 to the + input on the 3rd party device.
- Connect the – on terminal 8 to the – input on the 3rd party device.

**Note:** Ensure that a wire nut is installed on the Blue wire on the back of the module.

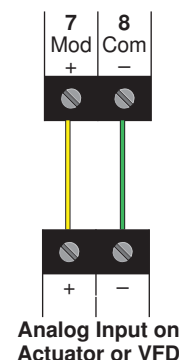



## ⚠ System Pump

*Red wire or Terminal 4*

The module includes two different methods to turn on a system pump.

1. Powered output on back of module.
  - Connect 120 V (ac) to the black wire.
  - Connect the mix system pump to the red wire.
  - Connect the ground to the green wire.
  - Connect the neutral wire to the mix system pump.
  - Ensure that a wire nut is installed on the blue wire (if not used).

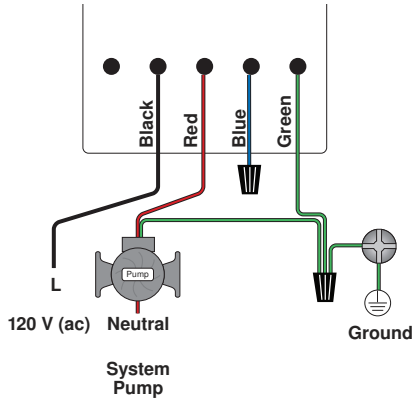

2. 24 V (ac) output on the front of the module.

- Connect the Sys Pmp terminal 4 to a Zone Manager 335 or 336 Pmp A input (terminal 3). Then wire the mix system pump to the Zone Manager 335 zone group pump A (terminals 30 and 31) or Zone Manager 336 zone group pump A (terminals 22 and 23).
- Connect the Sys Pmp terminal 4 to a Dual Zone Manager 337 Pmp B input (terminal 3). Then wire the mix system pump to the Dual Zone Manager 337 zone group pump B (terminals 29 and 31).

**Note:** Ensure that a wire nut is installed on the Red wire on the back of the module.

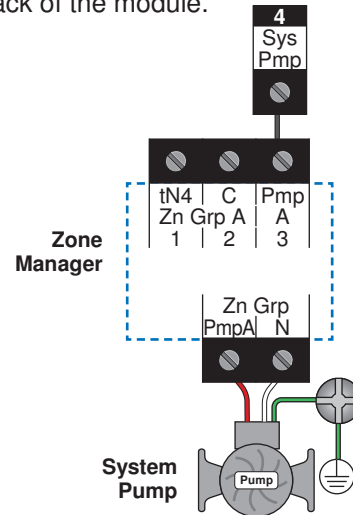

## ⚠ 24 V (ac) Power

*Terminals 2,3*

Wire 24 V (ac) to terminals R and C.

If a Zone Manager is used:

- Connect C on the 444 to C on the Zone Manager.
- Connect R on the 444 to R on the Zone Manager.

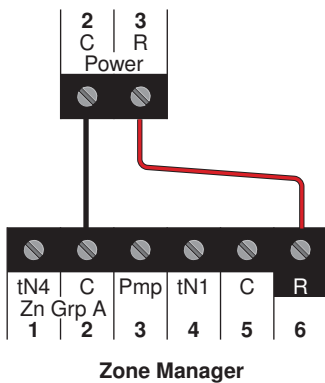

If a 24 V (ac) transformer is used:

- Connect C on the 444 to C on the transformer.
- Connect R on the 444 to R on the transformer.

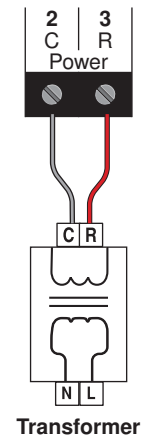

## ⚠ Mix Supply Sensor (tekmar 082)

*Terminals 8, 9*

- Ensure the Mix Supply Sensor is either tie strapped to the pipe or placed in a 1/2" OD immersion well.
- The sensor should be located on the supply pipe between the heating system and the mixing device.
- Connect the two wires from the Mix Supply Sensor to the Com and Mix (8 and 9) terminals.

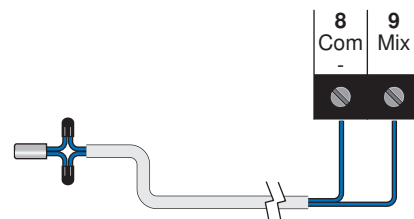

## **⚠ tN4 Communication**

*Terminals 1, 2*

Wire the tN4 communication to terminals tN4 and C on the desired tN4 mix temperature bus.

If a Zone Manager is used:

- Connect tN4 terminal 1 on the 444 to tN4 on the Zone Manager.
- Connect C terminal 2 on the 444 to C on the Zone Manager.

If a Zone Manager is not used:

- Connect tN4 on the 444 to tN4 on another tN4 device on the same mix tN4 bus.
- Connect C on the 444 to C on another tN4 device on the same mix tN4 bus.

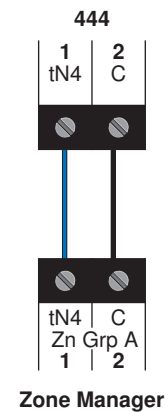

## **Troubleshooting the Wiring**

### **⚠ General**

The following tests are to be performed using standard testing practices and procedures and should only be carried out by properly trained and experienced persons.

A good quality electrical test meter, capable of reading from at least 0-300 V (ac), 0-30 V (dc), 0-2,000,000 Ohms, and testing for continuity is essential to properly test the wiring and sensors.

For an explanation on the use of the Test Button, the “Test” sequence or any error messages, refer to the Data Brochure of the tN4 System Control.

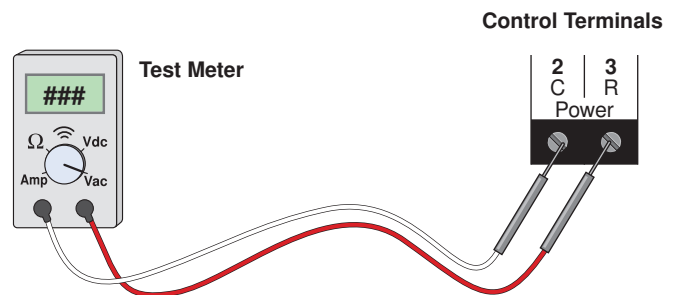

## **Testing the Module**

### **⚠ Testing the Power**

*Terminals 2, 3*

The Power LED is green when 24 V (ac) is applied to the C and the R terminals. Use a voltmeter to check for 24 V (ac) +/- 10% on terminals C and R.

### **⚠ Testing the tN4 Communication**

*Terminals 1, 2*

The tN4 Bus LED is green when the 444 detects communication. If the tN4 Bus LED is off, ensure that the tN4 and C wires are properly terminated on the 444 and at the device on the other end of the wires. The tN4 and C wires are polarity sensitive.

To check the tN4 and C wires, disconnect the wires on one end and connect them together using a wire nut. Then measure the other end of the wires using the continuity check on a digital multimeter.

## Testing the System Pump

*Terminals 2, 4*

The System Pump LED is green when the Pump contact is energized.

If using the output on the back of the module:

- Use a voltmeter to check for 120 V (ac) +/- 10% between the Red wire and neutral.

If using the 24 V (ac) output on the front of the module:

- Use a voltmeter to check for 24 V (ac) +/- 10% between the Sys Pmp and the C terminals.

## Testing tekmar Sensors

*Terminals 8, 9*

To test the sensors, the actual temperature at each sensor location must be measured.

- Use a good quality digital thermometer with a surface temperature probe for ease of use and accuracy. Where a digital thermometer is not available, strap a spare sensor alongside the one to be tested and compare the readings.

- Disconnect each sensor from the control.
- Test the sensors resistance according to the instructions in the sensor Data Brochure D 070.

## Testing the Variable Speed Injection Pump

*Back of Module*

- Press the Test button on the tN4 System Control.
- Once the Mix % Output reaches 100%, press the Test button once again to pause the control at this output.
- Measure the voltage on the variable speed injection pump. The reading should be 120 V (ac) +/- 10%.
- Press the Test button to resume the test sequence.

**Note:** At outputs below 100%, the electrical meter will not read correctly.

If power is not present:

- Measure the voltage on the Black wire and the neutral. The reading should be 120 V (ac) +/- 10%.
- If voltage is present on the Black wire but not on the Blue wire, and the Mix % Output is 100%, then the internal overload protection rated at 2.5 A may be damaged and require repair. Contact your tekmar sales representative for details on the repair procedures if this circuit is damaged.

## Testing the Floating Action

*Terminals 2, 5, 6*

- Press the Test button on the tN4 System Control.
- When the Mix % Out is increasing, use an electrical test meter to measure the (ac) voltage between the C terminal 2 and Opn (Open) terminal 5. The reading should be 24 V (ac) +/- 10%.

- When the Mix % Out is decreasing, use an electrical test meter to measure the (ac) voltage between the C terminal 2 and Cls (Close) terminal 6. The reading should be 24 V (ac) +/- 10%.

## Testing the Analog V (dc) Signal

*Terminals 7, 8*

- Press the Test button on the tN4 System Control.
- Once the Mix % Output reaches 100%, press the Test button once again to pause the control at this output.
- Set the multimeter to measure V (dc).

- Connect the multimeter probes to the analog modulating output terminals (7 and 8).
- The reading should be near 10 V (dc).

## Testing the Analog mA Signal

*Terminals 7, 8*

- Press the Test button on the tN4 System Control.
- Once the Mix % Output reaches 100%, press the Test button once again to pause the control at this output.
- Remove the wires from the analog modulating output terminals (7 and 8).

- Set the multimeter to measure mA.
- Connect the multimeter probes to the analog modulating output terminals (7 and 8).
- The reading should be near 20 mA.
- Replace wires.

## Technical Data

### Mixing Expansion Module 444; Variable Speed / Floating Action / Modulating

Control	Microprocessor PID control; This is <b>not a safety (limit) control</b>
Packaged weight	1.14 lbs (520 g)
Enclosure	White PVC plastic
Dimensions	4-3/4" H x 2-7/8" W x 1-7/8" D (120 x 74 x 48 mm)
Approvals	CSA C US, CSA/UL 61010-1, meets Class B: ICES and FCC Part 15
Ambient conditions	Indoor use only, 36 to 104 °F (2 to 40 °C)
	RH < 92% to 104 °F (40 °C)
	Altitude <9840 feet (3000 m), Installation Category II, Pollution Degree 2
Power Supply	24 V (ac) ±10% 50/60 Hz, 4 VA standby, 56 VA fully loaded
System Pump Relay (front)	24 V (ac) 2A
System Pump Relay (back)	120 V (ac) 5A
Variable Speed Output	120 V (ac) 2.4 A, internal overload circuit T2.5 A 250 V
Floating Output	24 V (ac) 8 VA maximum, triac output, minimum 0.6 VA
Modulating Output (voltage)	0 or 2-10 V (dc), minimum 10kΩ
Modulating Output (current)	0 or 4-20 mA, maximum 1kΩ
Sensors	NTC thermistor, 10 kΩ @ 77 °F (25 °C ±0.2 °C) β=3892
-Included	1 of Universal Sensor 082

The installer must ensure that this control and its wiring are isolated and/or shielded from strong sources of electromagnetic noise. Conversely, this Class B digital apparatus complies with Part 15 of the FCC Rules and meets all requirements of the Canadian Interference-Causing Equipment Regulations. However, if this control does cause harmful interference to radio or television reception, which is determined by turning the control off and on, the user is encouraged to try to correct the interference by re-orientating or relocating the receiving antenna, relocating the receiver with respect to this control, and/or connecting the control to a different circuit from that to which the receiver is connected.

Cet appareil numérique de la classe B respecte toutes les exigences du Règlement sur le matériel brouilleur du Canada.



tekmar Control Systems Ltd., Canada  
 tekmar Control Systems, Inc., U.S.A.  
**Head Office: 5100 Silver Star Road**  
**Vernon, B.C. Canada V1B 3K4**  
**(250) 545-7749 Fax. (250) 545-0650**  
**Web Site: www.tekmarcontrols.com**