

tekmar® - Wiring Brochure

Mixing Expansion Module 440



W440

12/08

- | | | | | | |
|---|--|--|---|--|--|
| <p>1 Information Brochure
Choose controls to match application</p> | <p>2 Application Brochure
Design your mechanical applications</p> | <p>3 Rough-in Wiring
Rough-in wiring instructions</p> | <p>4 Wiring Brochure
Wiring and installation of specific control</p> | <p>5 Data Brochure
Control settings and sequence of operation</p> | <p>6 Job Record
Record settings & wiring details for future reference</p> |
|---|--|--|---|--|--|

Overview

The following wiring brochure describes how to wire the tekmar Mixing Expansion Module 440. The 440 is to be installed in an enclosure together with a tekmar Zone Manager. The 440 controls one mixing device (either variable speed injection or floating action) and one system pump. The wiring of tekmarNet®4 (tN4) components is simple and cost effective.

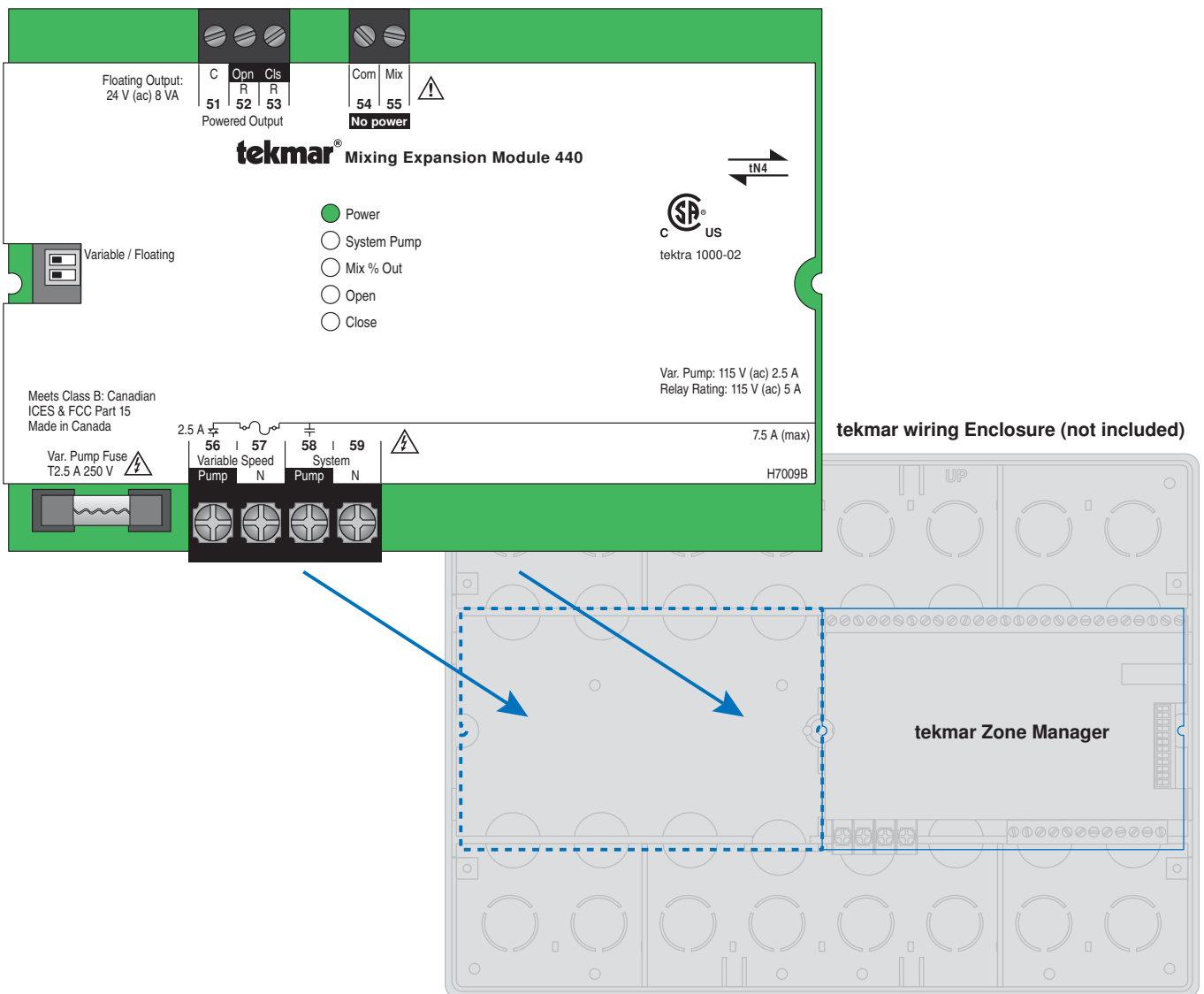











Table of Contents

Wiring Symbols & Definitions	2	Troubleshooting the Wiring	7
Module Installation	3	Testing the Control.....	7
Electrical Drawings	3-5	Technical Data.....	8
Wiring the Control	6		

Wiring Symbols

	Demand, signals control to operate. Requires a power and neutral connection. Use 24 to 260 V (ac), usually switched externally. Example: DHW Demand		Fuse, field replaceable.
	Dry contact switch. Operates a device. Example: Boiler		Black reverse lettering denotes an internally powered output.
	Powered switch. 24-115 V (ac) power, switched output to valve, pump, etc.		Do not apply power to these terminals. Serious control damage will result.
	Variable Power Switch. Varied power output to injection pump.		Earth ground
	tekmarNet®4		

Definitions

The following defined terms and symbols are used throughout this manual to bring attention to the presence of hazards of various risk levels, or to important information concerning the life of the product.



– Caution: Refer to accompanying documents



– Caution: Refer to accompanying documents

**INSTALLATION
CATEGORY II**

– Local level appliances

Caution

Improper installation and operation of this control could result in damage to the equipment and possibly even personal injury or death. It is your responsibility to ensure that this control is safely installed according to all applicable codes and standards. This electronic control is not intended for uses as a primary limit control. Other controls that are intended and certified as safety limits must be placed into

the control circuit. Do not attempt to service the control. Refer to qualified personnel for servicing. Apart from any field replaceable fuse(s) there are no user serviceable parts. Attempting to do so voids warranty and could result in damage to the equipment and possibly even personal injury or death.

Module Installation

Install the Mixing Expansion Module 440 in the left side of a tekmarNet®4 (tN4) wiring enclosure. The enclosure comes with a Zone Manager pre-installed in the right side. Review the figure below to understand the installation of the 440:

To Install the 440

1. Remove the front cover of the wiring enclosure by removing the two screws.
2. Remove the left side blank by removing the centre screw holding the blank and the Zone Manager in place. Make sure the Zone Manager stays in place.
3. Discard the blank.
4. The 440 has connector pins protruding from the underside of the board. The Zone Manager has wiring harnesses with plugs that connect to these pins.

Remove the required wiring harnesses from their retaining clips in the enclosure.

5. Carefully connect the Zone Manager's plugs onto the pins on the underside of the 440.
 - There is one smaller gauge connector with three pins and one larger gauge connector with 2 pins. These connectors can be installed only one way. Take care to ensure a good connection and avoid bending the pins.
6. Lower the 440 into the enclosure at an angle. Insert the two tabs on the left side of the 440 in to the corresponding slots in the left side of the wiring enclosure.
7. Lower the 440 toward the center of the enclosure until the two halves fit together. Make sure that the connector wires are placed underneath without pinching the wire.
8. Replace the center screw to hold the two controls in place.
9. Strip all wiring to a length of 3/8 in. or 10 mm for all terminals.

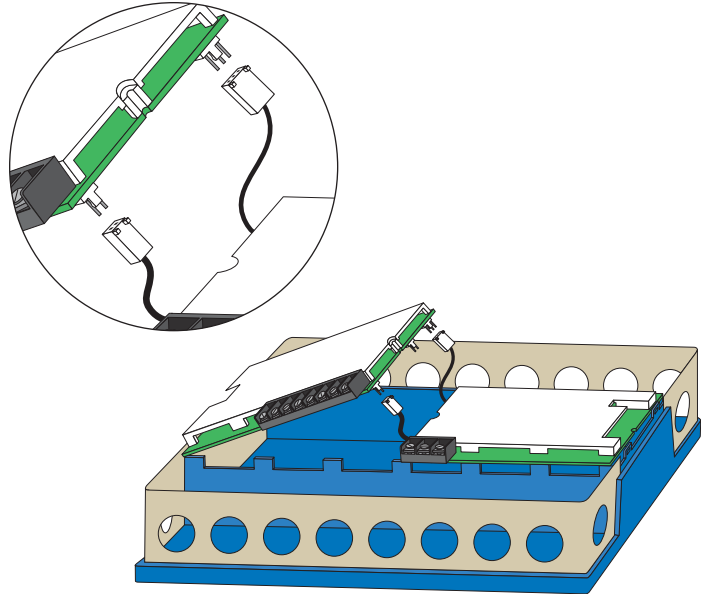

Electrical Drawings

⚠ The electrical drawing examples on the following pages show the 440 in common applications. Choose the drawing that most accurately depicts the components in your system and use that drawing as a guide to aid in wiring your system.

These are only concept drawings, not engineered drawings. They are not intended to describe a complete system nor any particular system. It is up to the system designer to

determine the necessary components for and configuration of the particular system being designed including additional equipment isolation relays (for loads greater than the controls specified output ratings) and any safety devices which in the judgement of the designer are appropriate in order to properly size, configure and design that system and to ensure compliance with building and safety code requirements.

Description: tekmarNet®4 Mixing Expansion Module 440; Variable Speed Mixing.

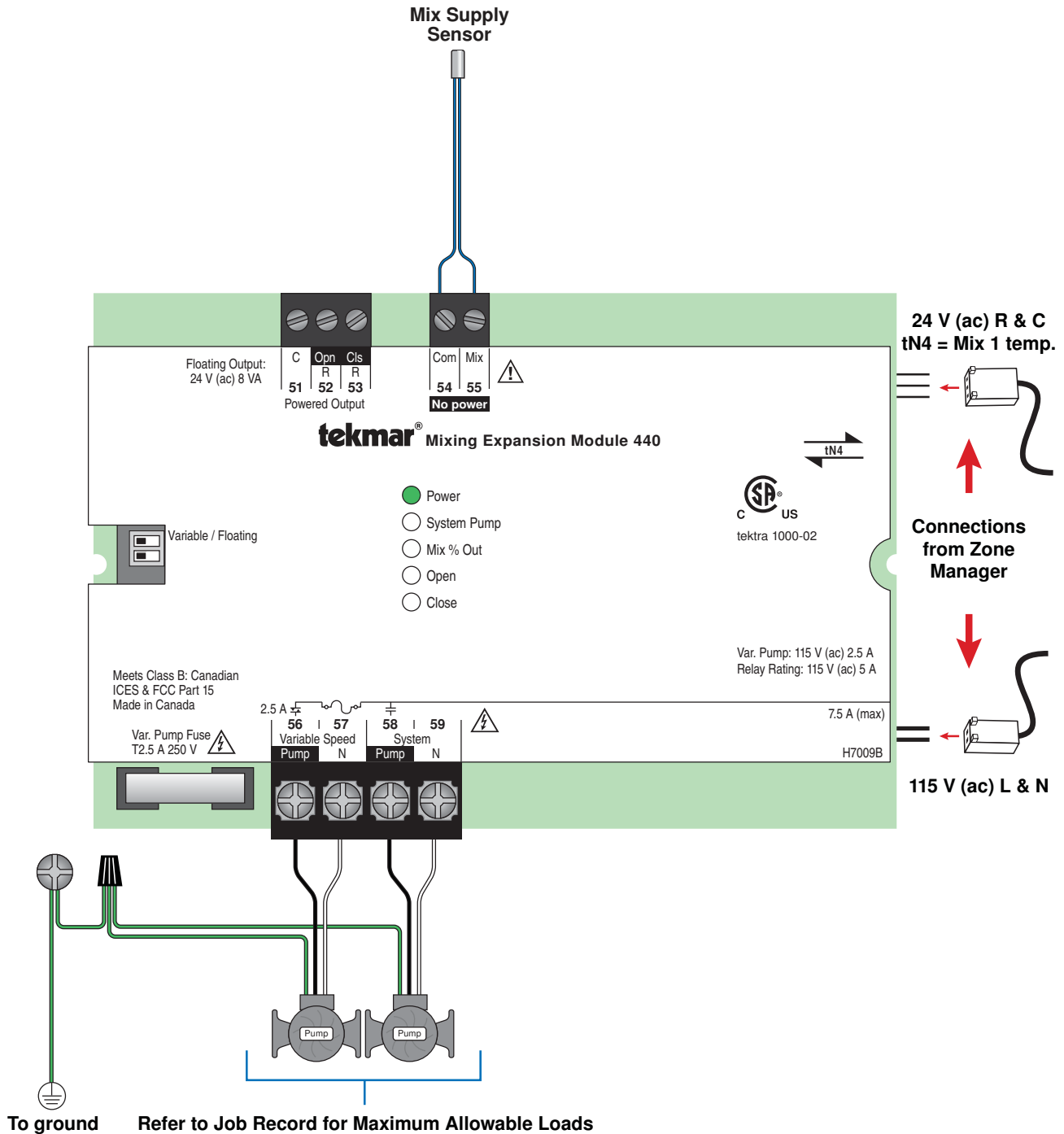

Description: tekmarNet[®]4 Mixing Expansion Module 440; 24 V (ac) Floating Action.

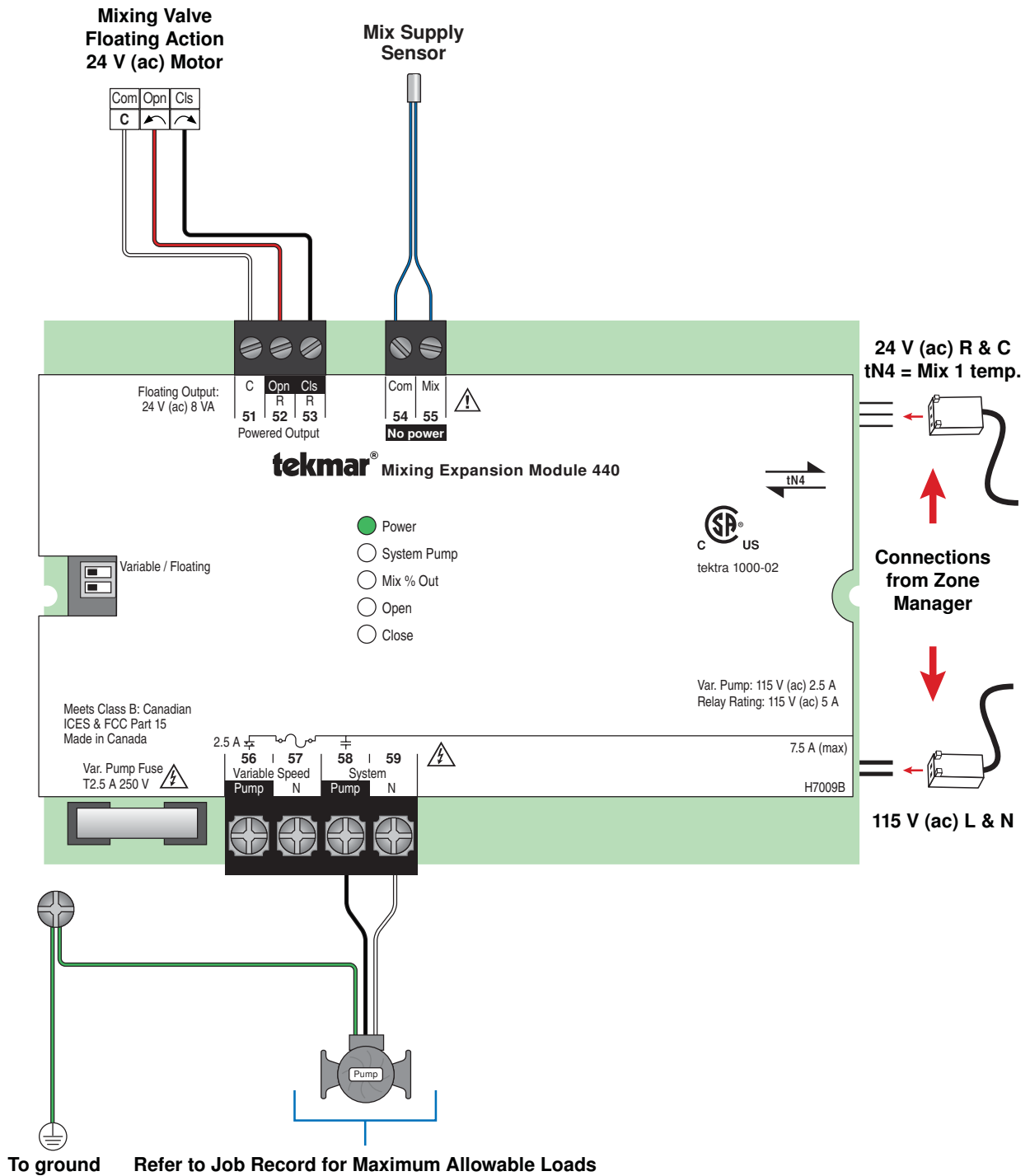

⚠ The following section explains how to wire individual devices to the Mixing Expansion Module 440. For step by step wiring refer to the terminal number on the right of the page.

- Before wiring ensure all power is turned off and take all necessary precautions.
- Install the supplied wiring compartment barriers by sliding them into the grooves provided as to isolate the low and high voltage wiring.

- Strip all wiring to a length of 3/8 in. or 10 mm for all terminals.
- Refer to the current and voltage ratings at the back of this brochure before connecting devices to this control.

⚠ Wiring a Floating Action Actuator (Mixing Valve)

Terminals 51-53

The control operates a 24 volt floating action (power open / power close) valve motor. Power is provided through an internal transformer to a maximum of 8 VA. Connect the wiring from the motor to terminals 51, 52, 53 where terminal 51 is 24 volt C (neutral) and terminal 52 is 24 V R (hot) for opening and terminal 53 is 24 V R (hot) for closing.

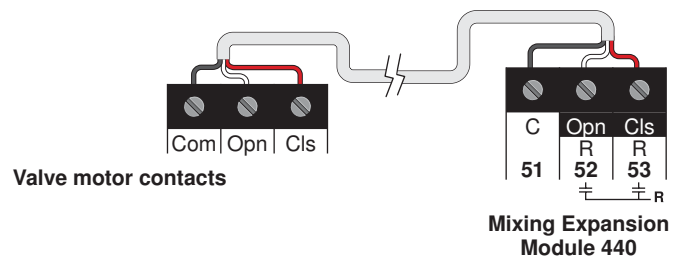

⚠ Mixed Sensor (tekmar 082)

Terminals 54-55

Connect the two wires from the Mix Sensor 082 to the Com and Mix (54-55) terminals. The Mix Sensor is used by the control to measure the mix supply temperature.

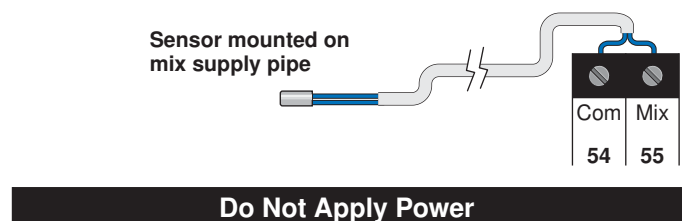

⚠ Variable Speed Pump

Terminals 56-57

The control varies the speed of a permanent capacitor, impedance protected or equivalent pump motor that has a locked rotor current of less than 2.4 A. Refer to Essay E 021 for a listing of approved pumps.

If a variable speed injection pump is used, the pump is wired directly to terminals 56 and 57.

The pump's ground wire is connected to the ground screw provided in the wiring chamber.

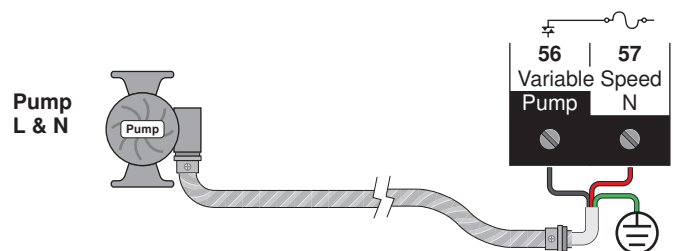

⚠ System Pump

Terminals 58-59

The control operates a System Pump

- If a System Pump is used, the pump is wired directly to terminals 58 and 59.
- The pump's ground wire is connected to the ground screw provided in the wiring chamber.

Note: For pumps larger than the control's rated capacity, an external isolation relay must be used.

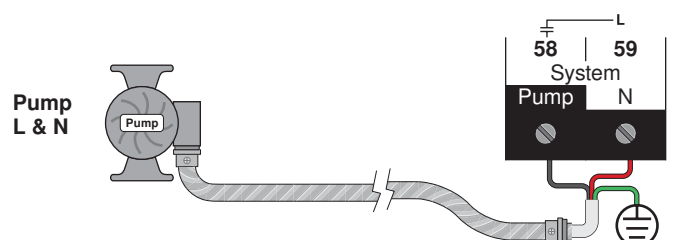

Troubleshooting the Wiring

⚠ General

The following tests are to be performed using standard testing practices and procedures and should only be carried out by properly trained and experienced persons.

A good quality electrical test meter, capable of reading from at least 0-300 V (ac), 0-30 V (dc), 0-2,000,000 Ohms, and testing for continuity is essential to properly test the wiring and sensors.

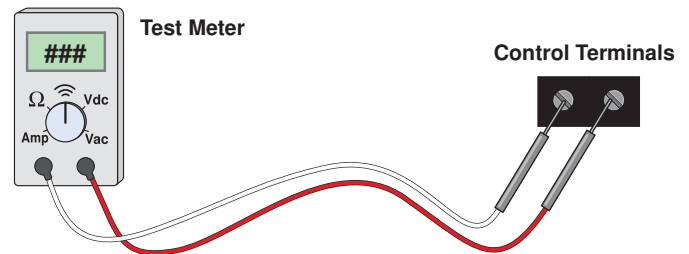

For an explanation on the use of the Test Button, the 'Test' sequence or any error messages, refer to the Data Brochure of the tN4 System Control.

Testing the Control

Terminals 51-59

⚠ Testing Floating Action (power open / power closed)

Terminals 51-53

1. Remove the front cover from the control.
2. Ensure that the control is set to operate the floating action output.
3. Press the Test button on the tN4 System Control.
4. When the Open LED is on, use an electrical test meter to measure the (ac) voltage between the C and R Opn (Open) terminals (51-52). The reading should be 24 V (ac) + / - 10%.
5. When the Close LED is on, use an electrical test meter to measure the (ac) voltage between the C and R Cls (Close) terminals (51-53). The reading should be 24 V (ac) + / - 10%.
6. If power is not present:
 - Check the power supply to the Zone Manager and the field replaceable fuse for the transformer on the Zone Manager.
 - If the fuse is blown, determine the cause of the failure before replacing the fuse.
 - Also check the Plug in connections on the underside of the control.
7. When the Open and Close LEDs are off, use an electrical test meter to measure the (ac) voltage between the C and R Opn (Open) terminals (51-52) and the C and R Cls (Close) terminals (51-53). The reading should be 0 V (ac).

⚠ Testing tekmar Sensors

Terminals 54-55

To test the sensors, the actual temperature at each sensor location must be measured.

- Use a good quality digital thermometer with a surface temperature probe for ease of use and accuracy. Where a digital thermometer is not available, strap a spare sensor alongside the one to be tested and compare the readings.
- Disconnect each sensor from the control.
- Test the sensors resistance according to the instructions in the sensor Data Brochure D 070.

⚠ Testing Variable Speed Injection Pump

Terminals 56-57

1. Remove the front cover from the control.
 2. Ensure that the control is set to operate the variable speed output.
 3. Press the Test button on the tN4 System Control.
 4. When the Mix % Out LED is on continuously, use an electrical test meter to measure the (ac) voltage between the Variable Speed terminals (56-57). The reading should be 115 V (ac) + / - 10%.
- Note:** at outputs below 100% the electrical test meter will not read accurately.
- If power is not present:
- Check the power supply to the Zone Manager and the field replaceable fuse for the variable speed output.
 - If the fuse is blown, determine the cause of the failure before replacing the fuse.
 - Also check the Plug in connections on the underside of the control.

⚠ Testing the System Pump

Terminals 58-59

1. Remove the front cover from the control.
 2. Press the Test button on the tN4 System Control.
 3. When the System Pump LED is on, use an electrical test meter to measure the (ac) voltage between the System Pump terminals (58-59).
- If power is not present:
- Check the power supply to the Zone Manager.
 - Also check the Plug in connections on the underside of the control.

Technical Data

Mixing Expansion Module 440; Variable Speed / Floating Action

Control	Microprocessor PID control; This is not a safety (limit) control
Packaged weight	1.16 lb. (526 g)
Dimensions	3-5/8" H x 5-3/8" W x 9/16" D (92 x 137 x 14 mm)
Approvals	CSA C US, CSA/UL 61010-1, meets Class B: ICES and FCC Part 15
Ambient conditions	Indoor use only, 32 to 122°F (0 to 50°C)
	RH ≤ 80% to 88°F (31°C), down to 50% from 104 to 122°F (40 to 50°C)
	Altitude <6560 feet (2000 m), Installation Category II, Pollution Degree 2
Power Supply	Provided by interconnected Zone Manager
System P1 Pump Relay	115 V (ac) 5 A
Variable Speed Pump	115 V (ac) 2.5 A
Combined Load	7.5 A Maximum (System and Variable Speed Pump)
Floating Action Output	24 V (ac) 8 VA Maximum
Sensors	NTC thermistor, 10k Ω @ 77°F (25°C ± 0.2°C) β=3892
-Included	1 Universal Sensor 082

The installer must ensure that this control and its wiring are isolated and/or shielded from strong sources of electromagnetic noise. Conversely, this Class B digital apparatus complies with Part 15 of the FCC Rules and meets all requirements of the Canadian Interference-Causing Equipment Regulations. However, if this control does cause harmful interference to radio or television reception, which is determined by turning the control off and on, the user is encouraged to try to correct the interference by re-orientating or relocating the receiving antenna, relocating the receiver with respect to this control, and/or connecting the control to a different circuit from that to which the receiver is connected.

Cet appareil numérique de la classe B respecte toutes les exigences du Règlement sur le matériel brouilleur du Canada.



tekmar Control Systems Ltd., Canada
 tekmar Control Systems, Inc., U.S.A.
Head Office: 5100 Silver Star Road
Vernon, B.C. Canada V1B 3K4
(250) 545-7749 Fax. (250) 545-0650
Web Site: www.tekmarcontrols.com