

Job Name _____
 Job Location _____
 Engineer _____
 Approval _____

Contractor _____
 Approval _____
 Contractor's P.O. No. _____
 Representative _____

Showerhead

Part No. 141-378

Part No. 141-379

Specifications

Description Ball Joint Showerhead with Adjustable Shower Pattern & Male Thread

Material Brass

Finish Polished Chrome

Agency/Spec Approval A112.18.1M
 CSA B125

Maximum Flow 2.5 gpm @ 80 psi
 (9.5 l/min @ 550 kPa)

Shipping Weight 141-378 0.9 lb (0.4 kg)
 141-379 1.3 lb (0.6 kg)



Dimensions

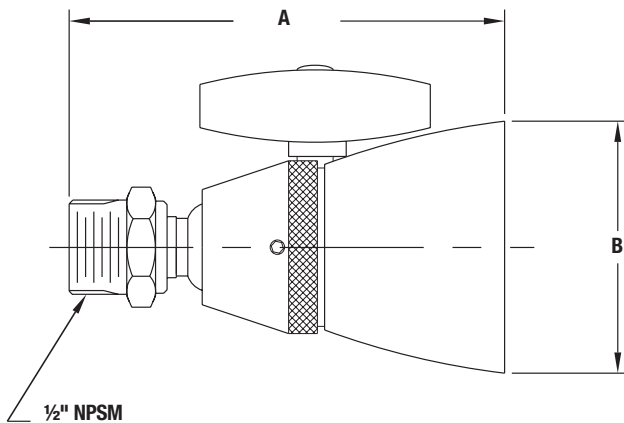

Indicate Desired Fitting

3	Part Number	A	B
<input type="checkbox"/>	141-378	3-1/4" (83mm)	1-3/4" (44mm)
<input type="checkbox"/>	141-379	3-3/4" (95mm)	2-1/4" (57mm)

Powers product specifications in U.S. customary units and metric are approximate and are provided for reference only. For precise measurements, please contact Powers Technical Service. Powers reserves the right to change or modify product design, construction, specifications, or materials without prior notice and without incurring any obligation to make such changes and modifications on Powers products previously or subsequently sold.

USA: Tel: (800) 669-5430 • Fax: (847) 229-0526 • PowersControls.com
Canada: Tel: (905) 332-4090 • Fax: (905) 332-7068 • PowersControls.ca
Latin America: Tel: (52) 81-1001-8600 • PowersControls.com

POWERS™
 A WATTS Brand