

Job Name \_\_\_\_\_

Contractor \_\_\_\_\_

Job Location \_\_\_\_\_

Approval \_\_\_\_\_

Engineer \_\_\_\_\_

Contractor's P.O. No. \_\_\_\_\_

Approval \_\_\_\_\_

Representative \_\_\_\_\_

# Series 4000B-FP

## Reduced Pressure Zone Assemblies

### Sizes: 1" – 2"

Series 4000B-FP Reduced Pressure Zone Assemblies are designed to protect potable water supplies in accordance with national plumbing codes and water authority requirements. This series can be used in a variety of installations, including the prevention of health hazard cross connections in piping systems or for containment at the service line entrance.

This series features two in-line, independent check valves, captured springs and replaceable check seats with an intermediate relief valve. Its compact modular design facilitates easy maintenance and assembly access.

### Features

- Single access cover and modular check construction for ease of maintenance
- Top entry — all internals immediately accessible
- Captured springs for safe maintenance
- Internal relief valve for reduced installation clearances
- Replaceable seats for economical repair
- Bronze body construction for durability — 1" to 2"
- Ball valve test cocks — screwdriver slotted — 1" to 2"
- Large body passages provides low pressure drop
- Compact, space saving design
- No special tools required for servicing
- Gear operated, slow close shutoffs
- Pre-wired tamper switch (2) per shutoff

### Specifications

A Reduced Pressure Zone Assembly shall be installed at each potential health hazard location to prevent backflow due to back-siphonage and/or backpressure. The assembly shall consist of an internal pressure differential relief valve located in a zone between two positive seating check modules with captured springs and silicone seat discs. Seats and seat discs shall be replaceable in both check modules and the relief valve. There shall be no threads or screws in the waterway exposed to line fluids. Service of all internal components shall be through a single access cover secured with stainless steel bolts. The assembly shall also include two gear operated slow close resilient seated isolation valves, four resilient seated test cocks and an air gap drain fitting. The assembly shall meet the requirements of: USC Manual 8th Edition†; ASSE Std. 1013; AWWA Std. C511; CSA B64.4. The assembly shall be an Ames Fire & Waterworks Series 4000B-FP.



2" 4000BM2-FP-GV

### NOTICE

The information contained herein is not intended to replace the full product installation and safety information available or the experience of a trained product installer. You are required to thoroughly read all installation instructions and product safety information before beginning the installation of this product.

Ames Fire & Waterworks product specifications in U.S. customary units and metric are approximate and are provided for reference only. For precise measurements, please contact Ames Fire & Waterworks Technical Service. Ames Fire & Waterworks reserves the right to change or modify product design, construction, specifications, or materials without prior notice and without incurring any obligation to make such changes and modifications on Ames Fire & Waterworks products previously or subsequently sold.



## Materials

Bronze body construction, silicone rubber disc material in the first and second check plus the relief valve. Replaceable polymer check seats for first and second checks. Removable relief valve seat, cover bolts.

Standardly furnished with NPT body connections. Series 4000B-FP furnished with gear operated, full port, resilient seated, bronze ball valve shutoffs.

## Standards

AWWA C511-92, IAPMO File No. 1563

## Approvals



Approved by the Foundation for Cross-Connection Control and Hydraulic Research at the University of Southern California.

## Pressure – Temperature

Suitable for supply pressures up to 175 psi (12.06 bar) and water temperature to 180°F (75°C) continuous.

## Available Models

**No suffix** Female NPT Inlet/Outlet

**GV** Grooved Inlet/Outlet

### NOTICE

Inquire with governing authorities for local installation requirements

## Dimensions – Weights

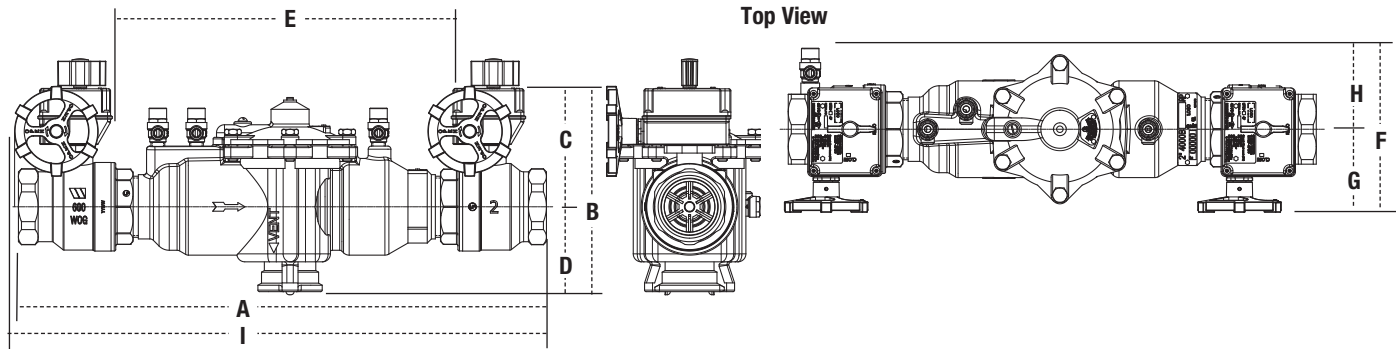

MODEL	SIZE	DIMENSIONS																WEIGHT					
		FNPT		GROOVED		B		C		D		E		F		G		H		I		lbs.	kgs.
	in.	in.	mm	in.	mm	in.	mm	in.	mm	in.	mm	in.	mm	in.	mm	in.	mm	in.	mm	in.	mm		
4000BM2-FP	1	13¼	337	13½	343	5¼	148	3½	89	2⅞	59	9¼	235	5¾	146	2⅞	73	2⅞	73	15⅝	397	15.8	7.2
4000BM2-FP	1¼	15⅝	397	16	406	6⅞	156	3¾	95	2⅞	60	11⅞	283	6¼	154	2⅞	73	3⅞	81	17⅞	454	19.1	8.7
4000BM2-FP	1½	16⅞	416	16½	419	6⅞	162	4	102	2⅞	60	11⅞	287	6¼	159	2⅞	73	3⅞	86	18⅞	473	20.8	9.4
4000BM2-FP	2	19⅞	486	19⅝	500	7 ½	191	4¼	108	3¼	83	13⅞	341	6½	165	2⅞	73	3⅞	92	21⅞	543	30.4	13.8

Strainer sold separately

\*\*Approved by the Foundation for Cross-Connection Control and Hydraulic Research at the University of Southern California.

# Capacity

Performance as established by an independent testing laboratory.  
 \*Typical maximum system flow rate (7.5 feet/sec., 2.3 meters/sec.)

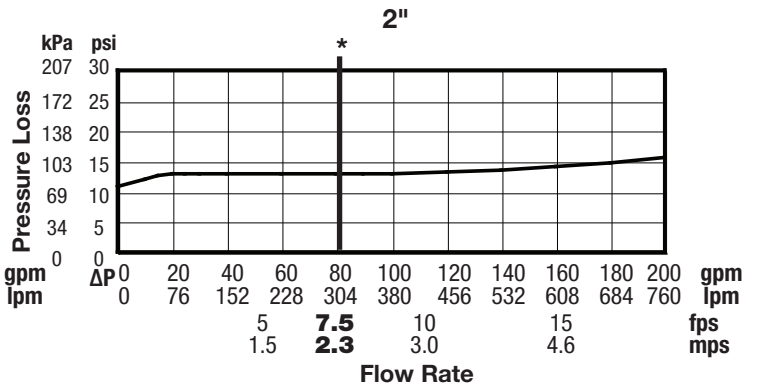
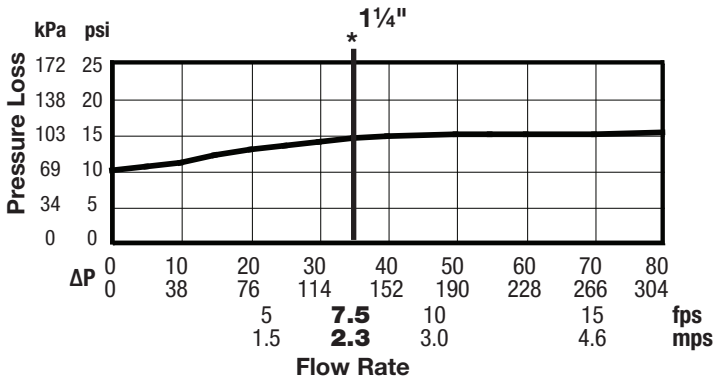
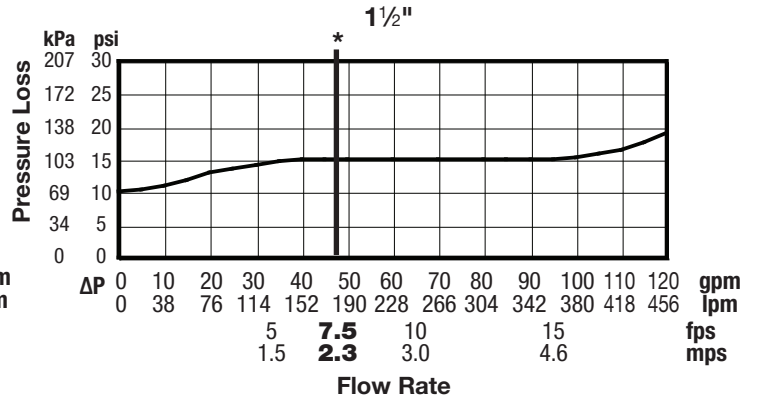
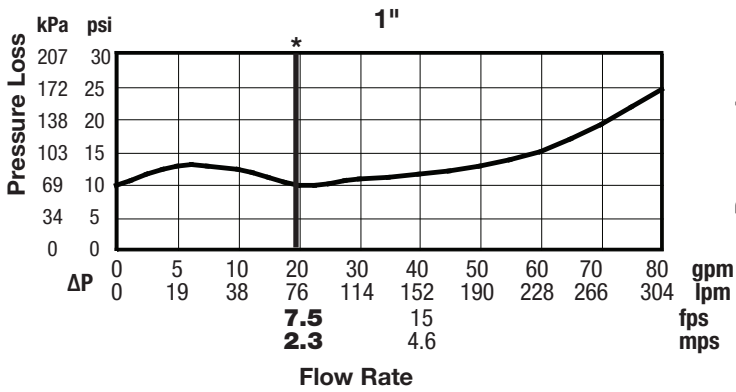

For additional information, visit our web site at: [AmesFireWater.com](http://AmesFireWater.com)



**A WATTS Brand**

---

**USA: Backflow** Tel: (978) 689-6066 • Fax: (978) 975-8350 • [AmesFireWater.com](http://AmesFireWater.com)  
**USA: Control Valves** Tel: (713) 943-0688 • Fax: (713) 944-9445 • [AmesFireWater.com](http://AmesFireWater.com)  
**Canada:** Tel: (905) 332-4090 • Fax: (905) 332-7068 • [AmesFireWater.ca](http://AmesFireWater.ca)  
**Latin America:** Tel: (52) 55-4122-0138 • [AmesFireWater.com](http://AmesFireWater.com)