

Job Name _____

Contractor _____

Job Location _____

Approval _____

Engineer _____

Contractor's P.O. No. _____

Approval _____

Representative _____

SD Heavy Duty Bronze Globe Control Valves

The rugged Powers Type SD (single seat bronze body) valve is primarily used for steam and water modulating applications with moderate pressure drops. The equal percent trim provides excellent control characteristics and is more tolerant of oversizing than linear or quick-opening plugs. Bronze trim is standard. The SD's control and close off characteristics are particularly well-suited to commercial water heaters and industrial applications.

Single Seat Bronze Body

- 3/4", 1", 1-1/4", 1 1/2", and 2" Screwed Ends
- ANSI Class 125 Body Rating
- ANSI Class IV Close off
- Bronze Trim with EPT Disc
- Equal Percent Flow Characteristic
- 46" Pneumatic Diaphragm, Field Reversible Actuator
- Stainless Steel Hardware
- NAMUR Standard Yoke for Accessories

FLOWRITE II®



NOTICE

The information contained herein is not intended to replace the full product installation and safety information available or the experience of a trained product installer. You are required to thoroughly read all installation instructions and product safety information before beginning the installation of this product.

NOTICE

Inquire with governing authorities for local installation requirements

Powers product specifications in U.S. customary units and metric are approximate and are provided for reference only. For precise measurements, please contact Powers Technical Service. Powers reserves the right to change or modify product design, construction, specifications, or materials without prior notice and without incurring any obligation to make such changes and modifications on Powers products previously or subsequently sold.

POWERS™
A WATTS Brand

Dimensional Information

(For other sizes consult factory)

Pneumatic Diaphragm Actuators

ACTUATOR*	A	B	LBS.
46"	10"	10-3/8"	14

Valve Body

SIZE	C	D	E	LBS.
3/4"	3-15/16"	2"	2-5/8"	3
1"	3-13/16"	2-1/8"	2-11/16"	4
1-1/4"	4-11/16"	2-1/2"	3-1/16"	6
1-1/2"	5-1/16"	2-3/4"	3-5/16"	8
2"	6-1/8"	3-1/8"	3-5/8"	13

*See Actuator Select Tables on page 5.

PNEUMATIC DIAPHRAGM ACTUATOR

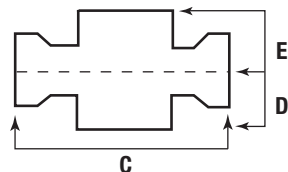
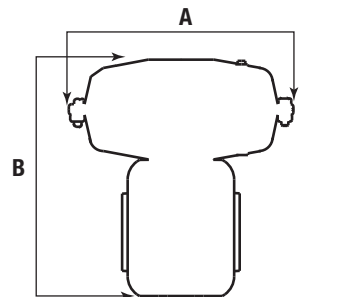

VALVE BODY

Application

- **Body Material and Rating.** Bronze body, ANSI Class 125 (3/4"–1"), ANSI Class 250 (1-1/4"–2"), screwed NPT ends. Refer to Body Temperature/Pressure Ratings table to insure your application fits in the acceptable operating range. Also determine that the valve body material is compatible with your media.
- **Trim Material.** Bronze, with soft EPT disc, 50 PSI limit..
- **Flow Coefficient (CV Rating).** Cv to be determined by a specifying Engineer or calculated data. Select a valve size that most closely matches the calculated Cv from the Flowing ΔP , Close Off ΔP , and Cv Ratings table.

Body Temperature/Pressure Ratings

ANSI Standard Ratings – Bronze Bodies

Temperature (°F)	Class 125 Lb. (psig)	Class 250 Lb. (psig)
-20 to 150	200	400
200	190	385
250	180	365
350	150	300
400	125	250

- **Liquid Service.** ΔP less than the quantity $(0.66 \times \text{inlet pressure}) + 10$. Additionally, flowing ΔP should not exceed 50 PSI.
- **Steam Service.** ΔP less than the quantity $(0.5 \times \text{inlet pressure}) + 7.35$. Additionally, flowing ΔP should not exceed 50 PSI.
- **Actuator Selection.** The actuator must have enough force to close off against line pressure or maximum ΔP .

The 3–15 and 1–17 columns in the Close Off ΔP and Cv Ratings table apply to valves with control signals coming directly from I/P transducers. The 0–30 (Positioner) column applies to valves using Accritem® type pneumatic controllers or valves equipped with a positioner or 0–30 PSI I/P transducer. If your close off ΔP exceeds the value in the table, it will be necessary to evaluate the use of an in-line shutoff valve or alternate control valve meeting your close-off ΔP requirements.

Type SD CLOSE OFF ΔP AND CV RATINGS

VALVE SIZE	CV RATING	PLUG TRAVEL	ACTUATOR CODES	MAXIMUM ΔP IN PSI AT CLOSE OFF					
				FAIL CLOSED			FAIL OPEN		
				SIGNAL TO ACTUATOR			SIGNAL TO ACTUATOR		
				PNEUMATIC			PNEUMATIC		
ACTUATOR	3-15 PSI	1-17 PSI	0-30 PSI	3-15 PSI	1-17 PSI	0-30 PSI			
3/4	6	3/4	46 / 4C	50	50	50	50	50	50
1	10	3/4	46 / 4C	50	50	50	50	50	50
1-1/4	16	1	46 / 4C	50	50	50	50	50	50
1-1/2	20	1	46 / 4C	50	50	50	50	50	50
2	38	1	46 / 4C	35	50	50	37	50	50

NOTE: A 50psi ΔP limit is imposed for trim life considerations.

NOTES:

- 1) A 200 PSI ΔP limit is imposed for trim life considerations.
- 2) Closeoff pressures can be substantially increased on the 46" diaphragm actuators by sacrificing full stroke capability for cases where total valve capacity is not required. There is no way to publish formulas for all possible combinations. A rule of thumb is that, generally, closeoff pressures listed in the 0-30 PSI column are possible with a 3-15 PSI control signal by adjusting preload to compromise full stroke.

Sizing reference

STEAM TABLE

Steam Pressure PSIG	Temp. °F	Temp. °C	Sensible Heat BTU/lb.	Latent Heat BTU/lb.	Total Heat BTU/lb.
0	212	100	180	971	1151
10	239	115	207	952	1159
25	266	130	236	934	1170
50	297	147	267	912	1179
75	320	160	290	896	1186
100	338	170	309	881	1190
125	353	178	325	868	1193
150	365	185	339	858	1197
200	387	197	362	838	1200
250	406	208	381	821	1202
300	422	217	399	805	1204
400	448	231	438	778	1216
500	470	243	453	752	1205
600	489	254	475	729	1204

RECTANGULAR TANK CAPACITY IN GALLONS

$$\text{Gallons} = \frac{\text{Height} \times \text{Width} \times \text{Length (inches)}}{230}$$

or

$$\text{Gallons} = H \times W \times L(\text{ft.}) \times 7.5$$

CIRCULAR TANK STORAGE CAPACITY IN GALLONS

$$\text{Storage} = 6D^2 \times L \text{ (Gallons)}$$

Where: D = tank diameter in Feet
L = length in Feet

Load Sizing Calculations

Heating Water with Steam

Quick Method

$$\text{Lbs. /hr.} = \frac{\text{GPM}}{2} \times \Delta T$$

Precise Method

$$\text{Lbs. / hr.} = \frac{\text{GPM} \times 500 \times \Delta T}{h_{fg}}$$

Heating or Cooling Water with Water

$$\text{GPM}_1 = \text{GPM}_2 \times \frac{\text{°F water}_2 \text{ temp rise or drop}}{\text{°F water}_1 \text{ temp rise or drop}}$$

Heating or Cooling Water

$$\text{GPM} = \frac{\text{BTU/hr.}}{(\text{°F water temp. rise or drop}) \times 500}$$

Heating Oil with Steam

$$\text{Lbs. /hr.} = \frac{\text{GPM}}{4} \times (\text{°F oil temp. rise})$$

Heating Air with Water

$$\text{GPM} = 2.16 \times \frac{\text{CFM} \times (\text{°F air temp. rise})}{1000 \times (\text{°F water temp drop or rise})}$$

Heating Liquids with Steam

$$\text{Lbs. / hr.} = \frac{\text{GPM} \times 60 \times \text{CP} \times \text{W}}{h_{fg}} \times \Delta T$$

Heating Liquids in Steam Jacketed Kettles

$$\text{Lbs. / hr.} = \frac{\text{GPM} \times \text{Cp} \times \text{S} \times 8.33}{h_{fg} \times t} \times \Delta T$$

General Liquid Heating

$$\text{Lbs. / hr.} = \frac{\text{W} \times \text{Cp}}{h_{fg} \times t} \times \Delta T$$

Heating Air with Steam

$$\text{Lbs. / hr.} = \frac{\text{CFM}}{900} \times \Delta T$$

Glossary of Terms

- t** = Time in Hours
- Cp** = Specific Heat of Liquid
- S** = Specific Gravity of Fluid
- W** = Weight in Lbs.
- ΔT** = Temperature rise of fall in °F
- h_{fg}** = Latent Heat of Steam

Conversion Factors

- 1 lb. Steam/Hr.** = 1000 BTU/Hr.
- 1 Cubic Meter** = 265 U.S. Gallons
- 1 Cubic Foot Water** = 62.4 lbs.
- 1 PSI** = 2.04 inches of Mercury
- 1 PSI** = 2.3 feet of Water
- 1 PSI** = 27.7 inches of Water
- 1 U.S. Gallon Water** = 231 Cubic inches
- 1 U.S. Gallon Water** = 8.33 lbs.

Ordering Information

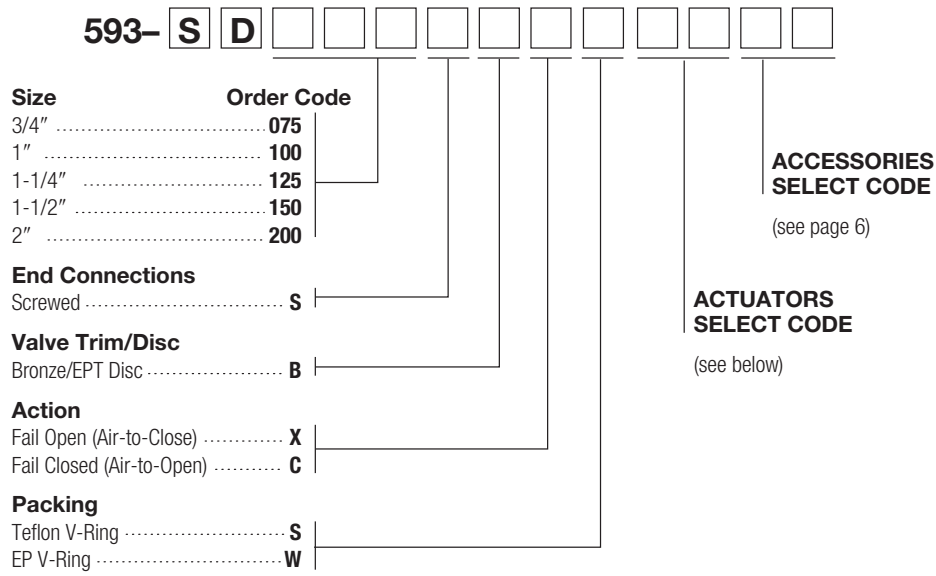

Actuator Select code

CODE	PNEUMATIC DIAPHRAGM ACTUATORS
46	46 Sq. In., 1" Max Valve Stroke with Standard Springs, adjustable start w/ 7 ~ 12 lb. Fixed span.
4C	46 Sq. In., 1" Max Valve Stroke with Extreme Cycle Springs, adjustable start w/ 7~ 12 lb. Fixed span.

Actuator compatibility

All Sizes Pneumatic Diaphragm: 46, 4C

Ordering Information (cont'd.)

Accessories Select code

BELLOFRAM 1000 I/P'S <u>Code Description</u> IS 3-15 psi TS 1-17 psi US 3-27 psi CONTROL/AIR TYPE 900X I/P <u>Code Description</u> ES 0-30 psi	UTILITY POSITIONER AND I/P <u>Code Description</u> BS 4-20 mA UTILITY POSITIONER <u>Code Description</u> PS 3-15 psi RS 3-9 psi SS 9-15 psi	NO ACCESSORIES <u>Code Description</u> OS No accessories
---	--	---

I/P Transducers

The "standard" 3-15 psi signal was originally designed as a transmission signal, not a valve actuation signal. Unbalanced control valves have their operational limits lowered when forced to operate with this 3-15 psi signal. The Fluid Controls Institute (in Standard 87-2) has recommended that a 1-17 psi air signal range be used when directly actuating a control valve without a positioner. Powers concurs with this recommendation, and therefore, offers a 1-17 psi I/P transducer and a 0-30 psi I/P transducer for maximum close-off. 3-15 psi I/P transducers should be used in conjunction with positioners.

Positioners

Positioners are used for one or more of the following reasons:

- 1) To split range valves.
- 2) To eliminate unwanted valve movement caused by line pressure variations
- 3) To minimize the effects of "stick-slip"
- 4) To speed response time and/or
- 5) To increase close-off rating when I/Ps are used.

Calculation/Sketch Area

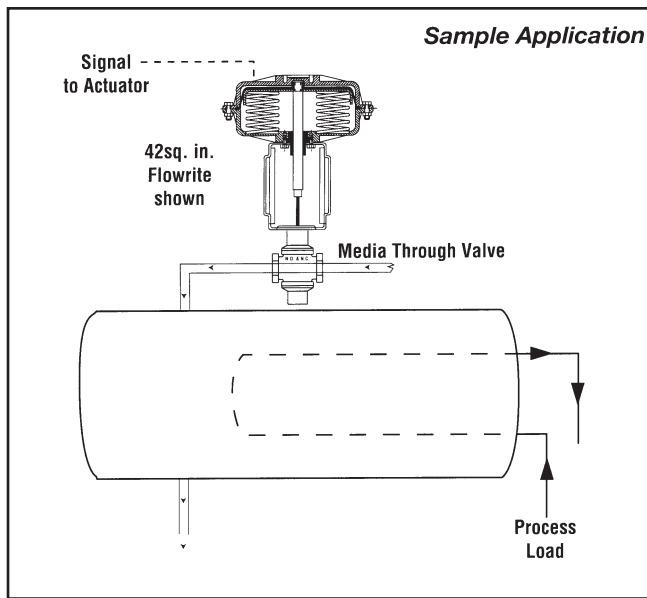

- Considerations: _____
- _____
- _____
- _____
- Medium: _____
- Capacity: _____
- Inlet Pressures: _____
- Pressure Drop: _____
- Temp.: (Packing): _____
- Fail Safe: _____

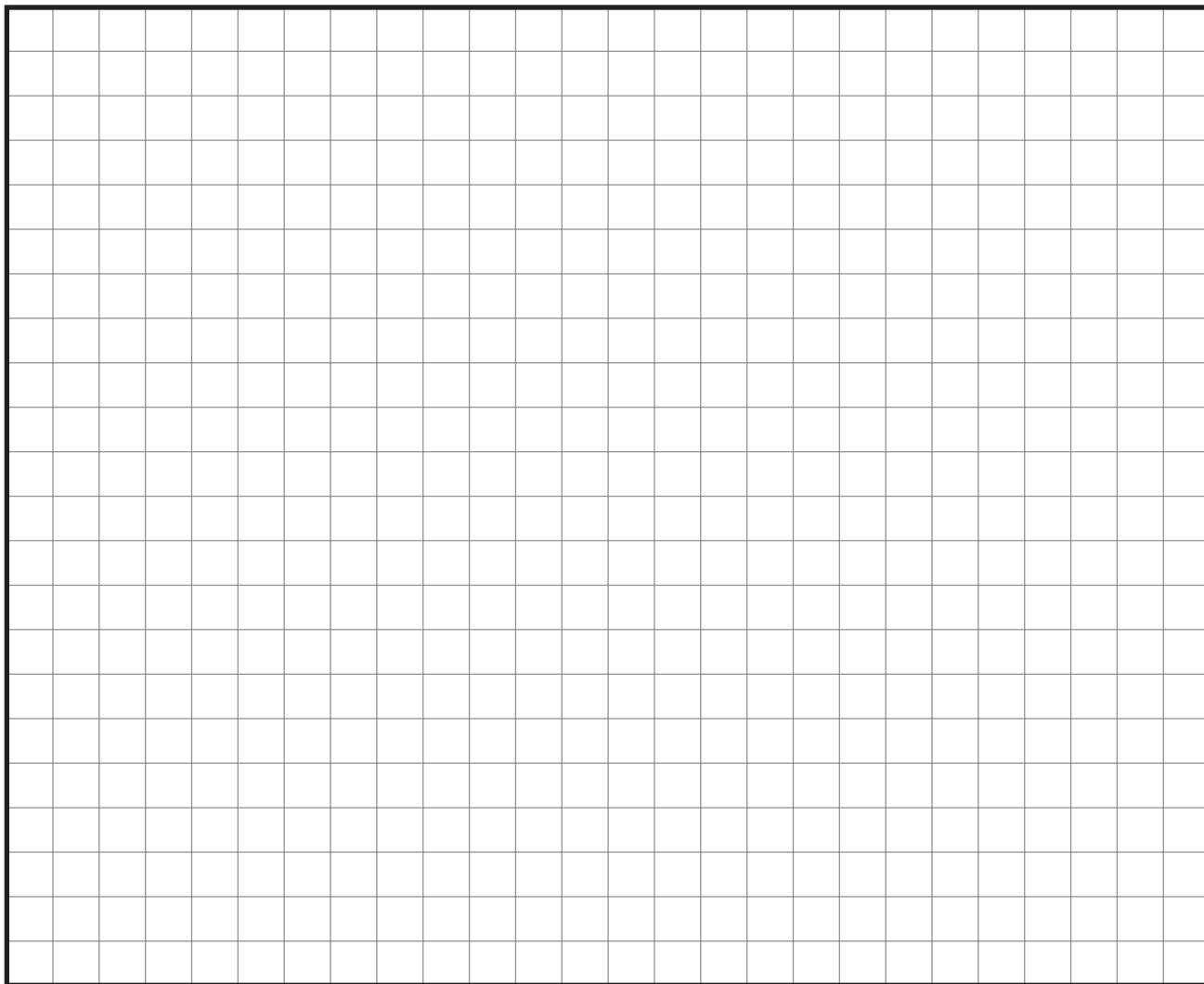



For more information on FLOWRITE II® or other quality Powers products,
visit us at our website Watts.com.

Pneumatic Temperature Controllers

Temperature Regulators

Mixing Valves

Control Valves

POWERS™

A WATTS Brand

USA: T: (800) 669-5430 • F: (847) 229-0526 • PowersControls.com

Canada: T: (905) 332-4090 • F: (905) 332-7068 • PowersControls.ca

Latin America: T: ((52) 55-4122-0138 • PowersControls.com