

## LFLM496-HTK Hot Water Tank Capacity Extender

### Technical Instructions

#### ⚠ WARNING



Read this Manual BEFORE using this equipment.

Failure to read and follow all safety and use information can result in death, serious personal injury, property damage, or damage to the equipment.



Keep this Manual for future reference.

#### ⚠ WARNING

**Need for Periodic Inspection/Maintenance:** This product must be tested periodically in compliance with local codes, but at least once per year or more as service conditions warrant. All products must be retested once maintenance has been performed. Corrosive water conditions, inlet temperatures over 200°F (93°C), and/or unauthorized adjustments or repair could render the product ineffective for the service intended. Regular checking and cleaning of the product's internal components helps assure maximum life and proper product function.

#### ⚠ WARNING

Local building or plumbing codes may require modifications to the information provided. You are required to consult the local building and plumbing codes prior to installation. If the information provided here is not consistent with local building or plumbing codes, the local codes should be followed. This product must be installed by a licensed contractor in accordance with local codes and ordinances.

#### Specification ■

Temperature Adjustment	80° to 120°F (27° to 49°C)
Approach Temperature	5°F (3°C) above set point
Maximum Operating Pressure	125psi (861 kPa)
Maximum Hot Water Temperature	200°F (93°C)
Cold Water Temperature Range	39° - 80°F (5° - 27°C)
Maximum Pressure Differential Between Hot and Cold Supplies	25%
Minimum Flow	0.5gpm (1.90lpm) when tested in accordance with ASSE1017 & ASSE 1070
Flow at 45psi pressure drop Listing (valve only)	13gpm (49lpm) ASSE 1017, ASSE1070 and IAPMO cUPC

+Thermostatic valve only



LFLM496-HTK



#### Installation ■

Valve should be installed and adjusted by a licensed contractor with local codes and ordinances. Further, this valve should be positioned to allow easy access for cleaning, service and adjustment.

1. Connect hot water side of the valve to the hot water outlet of the hot water tank. Make sure strainer gasket is in place.
2. Install elbow to the mixed outlet of the valve. Make sure gasket is in place.
3. Connect tee to the cold inlet of the hot water tank, ensuring that mixing valve connection is aligned to allow connection to the cold side of the thermostatic mixing valve with a corrugated stainless steel connector.
4. Connect female threaded side of the corrugated stainless steel connector to the cold inlet of the thermostatic mixing valve and male threaded side to the tee (as shown in Figure 1)
5. Install nipple to the tee and connect cold water inlet supply to the nipple
6. Connect system hot water outlet supply to the elbow connected to the thermostatic mixing valve outlet.
7. Turn on cold water supply and then hot water supply. Check for leaks.
8. Adjust temperature to desired setting (see Temperature Adjustment Section).

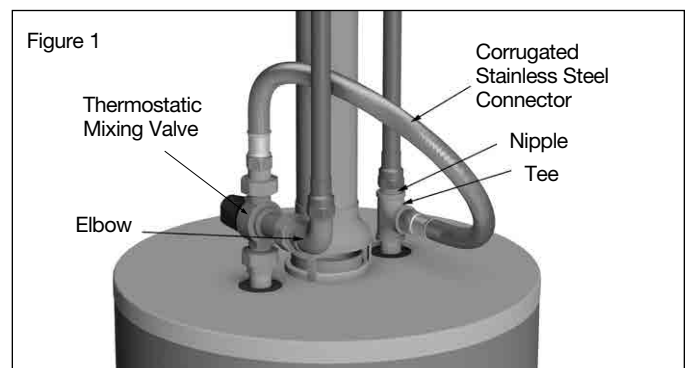

## Temperature Adjustment ■

1. Make sure hot water tank is turned on and supplying hot water to the thermostatic mixing valve
2. Turn hot water on at the nearest outlet which is being supplied by the valve. Let the water run for at least two minutes to allow supply temperature to stabilize. Make sure to use thermometer to measure the water temperature.
3. See below to adjust the temperature setting of the thermostatic valve (Figure 2)

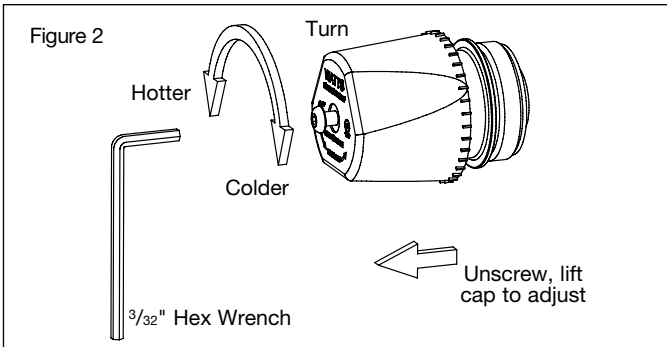

## Capacity\*\* ■

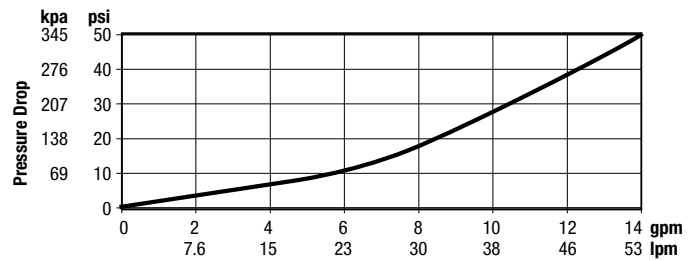

Flow curves are for reference. Actual flows may vary depending on system temperatures and/or pressures.

\*\*Flow curve with integral inlet filters and check valves

## Troubleshooting Guide ■

Symptom	Cause	Solution
Unable to reach required set point or set point difficult to set	<ol style="list-style-type: none"> <li>1. Supply temperatures not within specified limits</li> <li>2. Hot and cold supplies reversed</li> <li>3. Filters are blocked by debris</li> </ol>	<ol style="list-style-type: none"> <li>1. Check differential temperature between hot and cold supplies 5°F (3°) required</li> <li>2. Reinstall valve with supplies to correct connections</li> <li>3. Clean filters</li> </ol>
Unable to achieve required flow	<ol style="list-style-type: none"> <li>1. Too much pressure drop at the fixture</li> <li>2. Check valves /filters blocked by debris</li> </ol>	<ol style="list-style-type: none"> <li>1. Measure supply pressures and check against flow chart. Look for restrictions in valve or piping</li> <li>2. Clean check valves/filters</li> </ol>
Valve does not maintain required temperature or temperature changes over time	<ol style="list-style-type: none"> <li>1. Fluctuation in supply pressure</li> <li>2. Check valves /filters blocked by debris</li> </ol>	<ol style="list-style-type: none"> <li>1. Stabilize water pressures with pressure regulating or balancing valves</li> <li>2. Clean check valves/filters</li> </ol>
Discharge temperature too hot or too cold	Valve not calibrated properly	Readjust valve temperature per installation instructions
Valve is noisy	<ol style="list-style-type: none"> <li>1. Water velocity is too high</li> <li>2. Valve is not sized properly</li> </ol>	<ol style="list-style-type: none"> <li>1. Reduce water velocity with pressure regulating valve</li> <li>2. Check flow required versus rated flow capacity of the valve</li> </ol>
No flow from valve	Check valves /filters blocked by debris	Clean check valves/filters
Flow from the valve fluctuates	<ol style="list-style-type: none"> <li>1. Fluctuation in supply pressure</li> <li>2. Check valves /filters blocked by debris</li> </ol>	<ol style="list-style-type: none"> <li>1. Stabilize water pressures with pressure regulating or balancing valves</li> <li>2. Clean check valves/filters</li> </ol>

**WARNING:** This product contains chemicals known to the State of California to cause cancer and birth defects or other reproductive harm.  
**For more information: [Watts.com/prop65](http://Watts.com/prop65)**

## Warranty ■

The Seller warrants that the equipment manufactured by it and covered by this order or contract is free from defects in material and workmanship and, without charge, equipment found to be defective in material or workmanship will be repaired, or at Seller's option replaced F.O.B. original point of shipment, if written notice of failure is received by Seller within one (1) year after date of shipment (unless specifically noted elsewhere), provided said equipment has been properly installed, operated in accordance with the Seller's instructions, and provided such defects are not due to abuse or decomposition by chemical or galvanic action. THIS EXPRESS WARRANTY IS IN LIEU OF AND EXCLUDES ALL OTHER WARRANTIES, GUARANTEES, OR REPRESENTATIONS, EXPRESS OR IMPLIED. THERE ARE NO IMPLIED WARRANTIES OF MERCHANTABILITY OR OF FITNESS FOR A PARTICULAR PURPOSE. The Seller assumes no responsibility for repairs made on the Seller's equipment unless done by the Seller's authorized personnel, or by written authority from the Seller. The Seller makes no guarantee with respect to material not manufactured by it.

# POWERS™

A Watts Water Technologies Company

USA: Tel: (800) 669-5430 • Fax: (847) 229-0526 • [PowersControls.com](http://PowersControls.com)

Canada: Tel: (905) 332-4090 • Fax: (905) 332-7068 • [PowersControls.com](http://PowersControls.com)

Latin America: (52) 81-1001-8600 • Fax: (52) 81-8000-7091 • [PowersControls.com](http://PowersControls.com)