

INSTALLATION INSTRUCTIONS

POWERS™

VisuGuard® LCD

PRESSURE-BALANCING TEMPERING VALVE WITH LCD TEMPERATURE DISPLAY

Note: Installation should be in accordance with accepted plumbing practices. Finish all piping thoroughly before installation.

VALVE PIPING

1. Facing the front of the mixer, connect hot water supply to the left side and cold water to the right side of the valve. These supply inlets must be piped correctly or the valve will not mix properly (inlets are labeled on the bonnet). If supply lines are reversed, see "mixing plate rotation."
2. All VisuGuard LCD mixers are supplied for 4-port applications and can be modified for 3-port applications by using the included $\frac{5}{8}$ " sweat plug. Refer to "Dimensional Data" to determine proper installation.
3. Do not remove the rough-in guide; you will use it to position mixer to the proper depth within the wall later.
4. If copper tubing is used, use flared fittings to connect tubing to mixer. The heat generated during the solder operation could damage the internal parts of the mixer. Inlet checkstops for direct sweat connections are available.

If flared fittings or checkstops cannot be used, remove the balance chamber before soldering (see balance chamber removal).

TRIM PLATE / HANDLE ASSEMBLY

Refer to exploded view to identify parts.

1. Using the rough-in guide to aid in cutting the proper access hole into the finished wall.
2. Apply the adhesive trim plate gasket to the inside edge of the trim plate. Proper application results in approximately $\frac{1}{4}$ " gasket compression against finished wall.
3. Remove rough-in guide.



Model F473 shown

ADA-compliant handle operation 

4. Locate and insert the thermistor (temperature probe) into the supplied compression fitting at the mixer outlet. See proper probe depth below (Figure 1). Improper installation of depth probe can result in imprecise temperature readings. Firmly tighten to prevent leakage.
5. Apply trim plate to wall (valve handle inserted through trim). Do not hang trim plate on wall using temperature probe wire as this could cause damage to probe.
6. At this point it is wise to pressurize and test the system to verify zero leakage and set maximum temperature settings prior to finishing the trim application.
7. Maximum temperature setting adjustment: To change setting, remove splined stop by slipping O-ring up on stem. Rotate temperature adjustment stem to desired maximum temperature. Position splined stop on the adjustment stem so that it contacts the bonnet stop. Replace O-ring.

(continued on other side)

Figure 1: Probe Figure

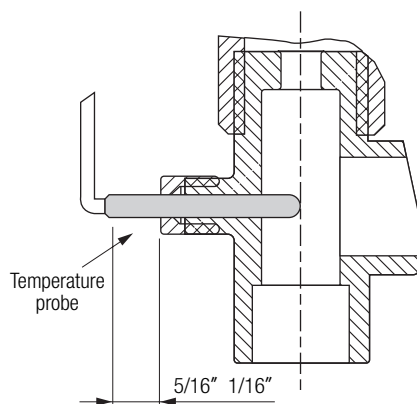

Figure 2

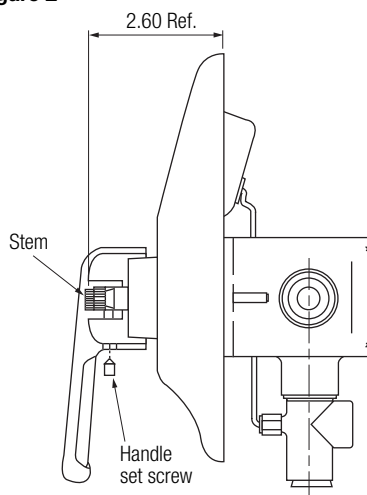
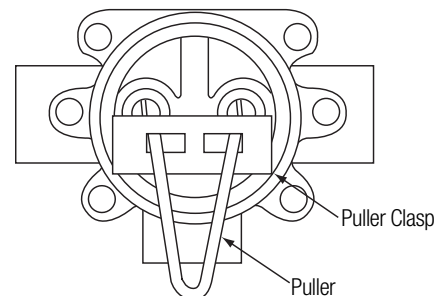

Figure 3



CAUTION: Resetting of the spline stop can result in higher temperatures. The mixer senses inlet pressure changes only, so any variation in the inlet temperatures will affect the control point and the desired maximum temperature setting.

8. Verify that the stem dimension as shown in figure 2.
9. Locate, install, and tighten the trim plate with mixer stem passing through it.
10. Apply adhesive stem gasket to trim plate with mixer passing through it.
11. Locate and install the lever handle and its set screw (handle should be pointing down when turned fully clockwise). The set screw should then be tightened into the stem groove as shown in figure 2.

MIXING PLATE ROTATION

1. Remove the four bonnet screws.
2. Remove bonnet and rotate valve stem 1/2 turn.
3. Reinstall bonnet with four bonnet screws.

BALANCE CHAMBER REMOVAL

1. Remove the four bonnet screws and the bonnet.
2. Remove the balance chamber carefully with pliers or the cartridge puller p/n 401-202 (see figure 3).
3. Replace the cartridge and bonnet after finishing soldering. Use silicone grease to lubricate cartridge O-rings prior to reinsertion.

Figure 4: Exploded View

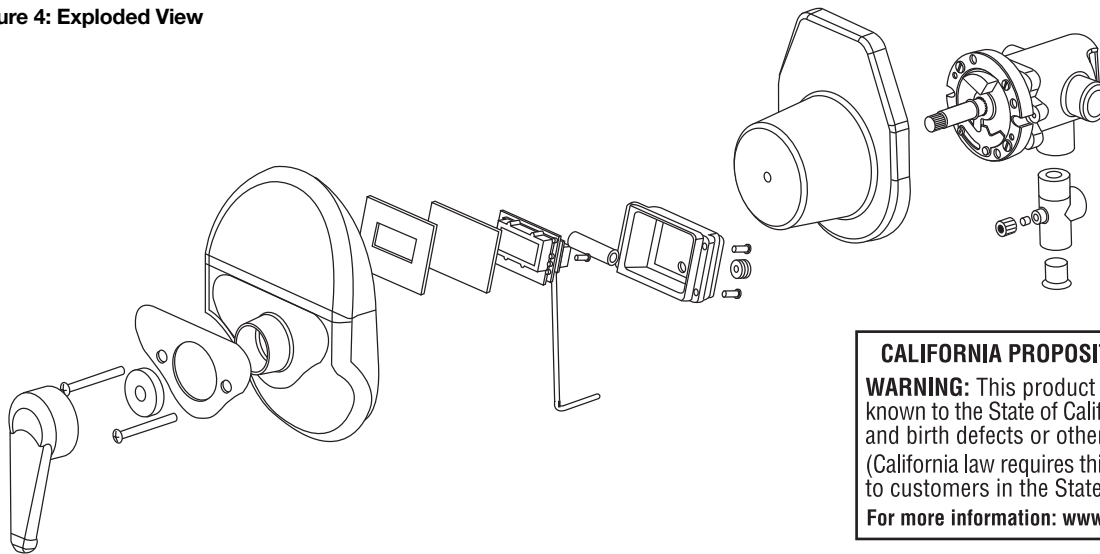

CALIFORNIA PROPOSITION 65 WARNING
WARNING: This product contains chemicals known to the State of California to cause cancer and birth defects or other reproductive harm. (California law requires this warning to be given to customers in the State of California.)
 For more information: www.watts.com/prop65

DIMENSIONAL DATA (millimeters [inches])

Front View

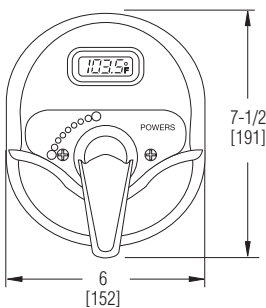

All dotted line piping supplied by others.
 Celcon is a registered trademark of Hoechst Celanese Corporation.

Tub and Shower Installation

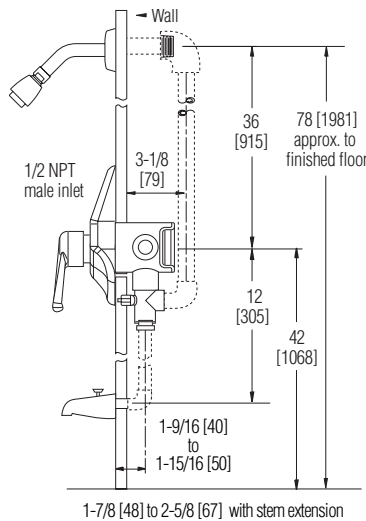

Shower Only Installation

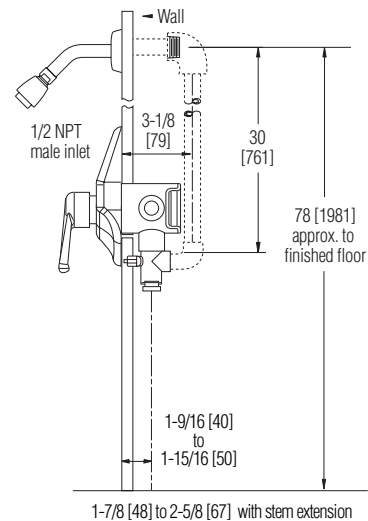

POWERS™
 a division of Watts Water Technologies, Inc.

© November 2001 Powers
 USA Phone: 800.669.5430 • Fax: 847.229.0526
 Canadian office: Phone: 888.208.8927 • Fax: 888.882.1979
www.powerscontrols.com