

Instructions for Installing

#11 Regulator

3-Way Water Mix (Type WM)

WARNING

 **Read this Manual BEFORE using this equipment. Failure to read and follow all safety and use information can result in death, serious personal injury, property damage, or damage to the equipment. Keep this Manual for future reference.**

THINK SAFETY FIRST

Valve Description

The Powers #11 Water Mix Regulator is a self-actuating control valve which automatically maintains a mixture of hot and cold water at the desired set point without the use of external power. Adjust the set point and the rugged self-operating #11 Regulator controls the mix of hot or cold water to maintain a constant temperature.

The instrument has a vapor pressure thermal system containing a thermally responsive fluid. This thermal system rapidly senses temperature changes at the bulb and accordingly positions the valve disc or plug, regulating hot and cold water flow to maintain the desired set point. The thermal system features a two-ply brass bellows with six reinforcing ribs on the bellows head and thick capillary tubing walls to insure long operating life.

Features

- Tight disc shutoff when either of the two inlet ports are closed (up to 2")
- EPT disc is replaceable (on 3/4" - 2" valves).
- Lower guide stabilizes valve plug, assisting shutoff and modulation.
- EPT spring loaded V-ring packing provides good sealing and long life.
- A valve stem of highly polished corrosion resistant grade 316L stainless steel to decrease friction and reduce hysteresis.
- An adjusting nut mounted on ball bearings and a removable set point adjusting rod ease set point adjustments
- A set point reference scale aids temperature adjustment

Operation

The #11 Regulator should be installed with the hotter of the two liquids going into the bottom 'B' port and the cooler liquid going into the upper 'U' port.

(A) When the temperature of the mixed liquid drops below the set point, the temperature of the thermally responsive fluid decreases, which decreases the vapor pressure in the bulb/bellows. The force of the resulting vapor pressure is less than the spring force, so the bellows contract and the spring extends, which raises the valve plug up to decrease flow through the

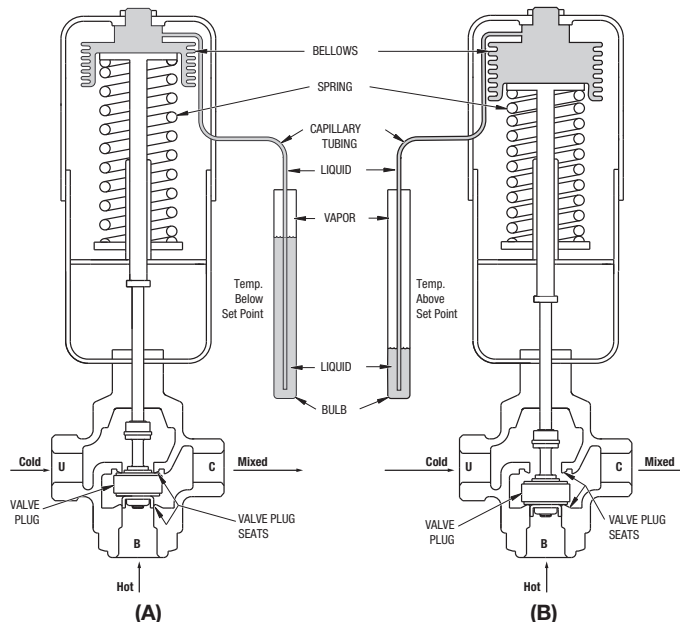

upper 'U' port (cold) and increase flow through the bottom 'B' port (hot). This raises the temperature of the flow out of the common 'C' port toward the set point.

(B) As the temperature increases toward or beyond the desired set point, the temperature of the thermally responsive fluid in the bulb increases, which causes the vapor pressure to increase. This expands the bellows, compresses the spring, and moves the valve plug down to increase flow through the upper 'U' port (cold) and decrease flow through the bottom 'B' port (hot). This lowers the temperature of the flow out of the common 'C' port toward the set point.

Table of Contents

Valve Description	1
Operation	1
Applications	2
Specifications	3
Sizing and Selection	3
Maximum Water Capacities	4
Product Identification	5
Installation	5
Maintenance	6
Preventive Maintenance	9
Troubleshooting	9
Dimensions	10
Parts List	12
Accessories	14
Temp. Ranges/Bulb Sizes	14
Ordering Code	15
Warranty Information	16

Applications

⚠ WARNING

In domestic water system, a safety shutdown device should be installed in conjunction with a #11 regulator. Failure of the #11 thermal system will result in a constant rise in temperature (or constant high temperature) of the fluid which you are trying to control.

Powers #11 Water Mix Regulators are typically used for automatic control of domestic or process water tempering. The self-actuated regulator can easily be installed in any convenient location. Among its applications are: two-temperature hot water systems, jacket water cooling of engines or compressors, and many other industrial processes. Below are two typical applications.

The three-way regulator can also be used for bypass control, in lieu of a diverting valve, but it must be piped as a mixing valve, with two inlets and one outlet.

Two temperature hot water system

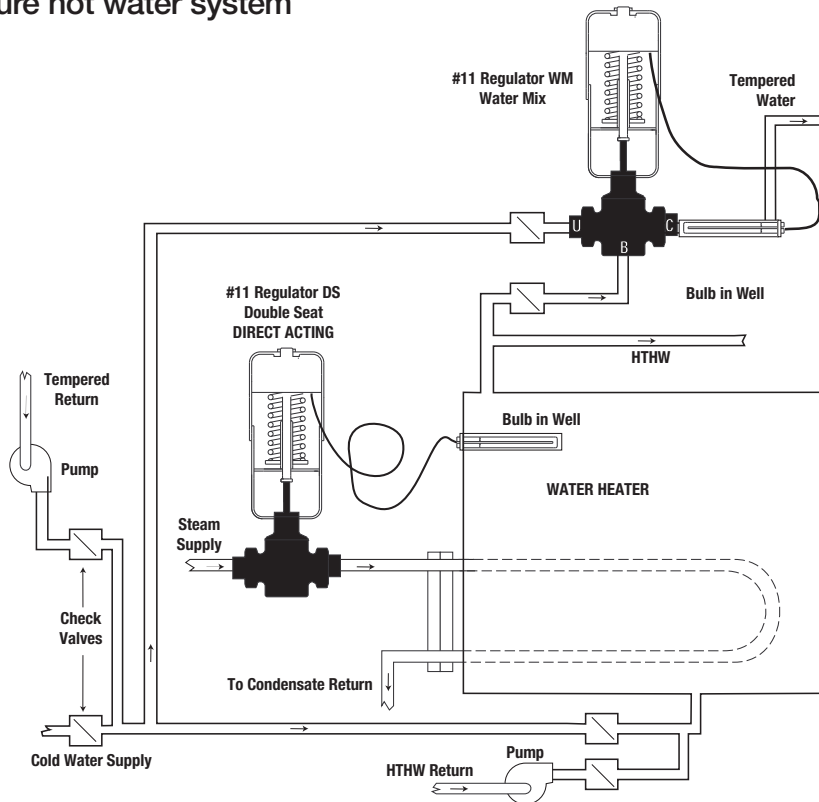

U = Upper Port/Cold Water Inlet
 B = Bottom Port/Hot Water Inlet
 C = Combination Port/Mixed Water Outlet

Jacket Water Cooling Application

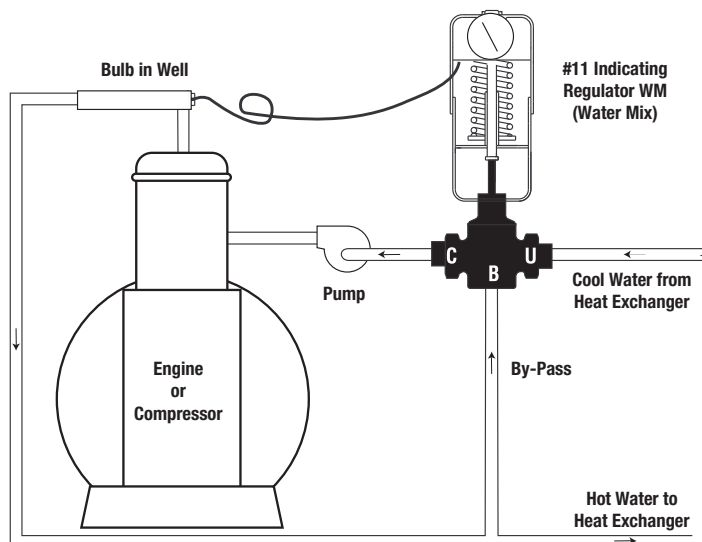

Specifications

		VALVE SIZES
PHYSICAL SPECS		3/4", 1", 1-1/4", 1-1/2", 2"
	Valve Plug Travel	See table on page 10
	Effective Bellows	Area 7.8 sq. in. (50.3 sq. cm.)
	Body Material	Bronze
	Body Rating	ANSI Class 125
	Connections	Screwed Ends
	Style	Composition Disc
	Max. Body Temperature	400°F (204°C)
OPERATING SPECS	Temperature Range	See bulb spec on page 13
	Controlled Medium	Water
	Max. Differential Pressure	See Tables on pp. 3 & 4
	Max. Allowable Overheat Temp.	25°F (14°C) above temp. range
	Max. Well Safe Pressure	See Tables on page 11
	Max. Body Pressure	125 psig
	Shipping Weight	See Table on page 10
	Flow Characteristics	Linear
	Shutoff Class Rating	ANSI Class IV
	Leakage	<0.01% of rated valve capacity

Sizing and Selection

Proper sizing of the Regulator is essential for correct system operation. An undersized Regulator will not allow sufficient flow at maximum load. An oversized Regulator may cycle and will not utilize the full valve stroke for efficient modulation of flow. This results in poor control and shortened valve life (quicker deterioration of valve disc and seat). For these reasons, the correct sizing of the Regulator for actual expected conditions is considered essential for good control.

Note: Select temperature range (see page 14) with the set point in the upper third for best valve performance.

Size the #11 Regulator for actual rather than maximum conditions. DO NOT size according to pipe size; piping systems are designed for different criteria than process controls. Refer to Powers document AE-1 — “Valve Selection and Sizing” — for further recommendations.

Maximum Operating Pressure Differential (differential for fluid flow): In order for the process medium to flow, a pressure drop must exist across the valve. “Pressure differential” is the difference in valve pressure between the inlet and outlet under flow conditions. The greater the differential, the greater the flow at any given plug position.

Though the regulator should be sized for actual conditions, you need to know the available differential at maximum flow. For optimum control, take as much differential as possible across the valve.

Refer to Maximum Water Capacities tables on page 4.

Maximum Water Capacities

⚠ CAUTION

Do not exceed maximum pressure differentials for given valve sizes. The maximum differential is the pressure the valve has against it at shutoff. Too large a differential can cause valve chatter and/or prevent shutoff.

TEMPERING Applications - Maximum MIXED FLOW

Gallons Per Minute

VALVE SIZE	Cv	AVAILABLE SIZING PRESSURE DIFFERENTIAL --- PSI										
		2	4	6	8	10	15	20	25	30	40	50
3/4"	7.2	10	14	18	20	23	28	32	36	39	46	51
1"	12	17	24	29	34	38	46	54	60	66	76	85
1-1/4"	20	28	40	49	57	63	77	89	100	110	126	141
1-1/2"	25	35	50	61	71	79	97	112	125	137	158	177
2"	39	55	78	96	110	123	151	174	195	214	247	276

Liters per Second

VALVE SIZE	Cv	AVAILABLE SIZING PRESSURE DIFFERENTIAL --- KPA											
		7	15	30	45	60	75	100	125	150	200	250	350
3/4"	7.2	0.5	0.7	0.9	1.2	1.3	1.5	1.7	1.9	2.1	2.4	2.7	3.2
1"	12	0.8	1.1	1.6	1.9	2.2	2.5	2.9	3.2	3.5	4.1	4.6	5.4
1-1/4"	20	1.3	1.9	2.6	3.2	3.7	4.2	4.8	5.4	5.9	6.8	7.6	9
1-1/2"	25	1.6	2.3	3.3	4	4.7	5.2	6	6.7	7.4	8.5	9.5	11
2"	39	2.5	3.6	5.1	6.3	7.3	8.1	9.4	10	11	13	15	18

BYPASS Applications - FULL FLOW thru BOTTOM Port (Top Closed)

Gallons Per Minute

VALVE SIZE	Cv	AVAILABLE SIZING PRESSURE DIFFERENTIAL --- PSI										
		2	4	6	8	10	15	20	25	30	40	50
3/4"	6	8.5	12	15	17	19	23	27	30	33	38	42
1"	8.9	13	18	22	25	28	34	40	45	49	56	63
1-1/4"	16	23	32	39	45	51	62	72	80	88	101	113
1-1/2"	18	25	36	44	51	57	70	80	90	99	114	127
2"	30	42	60	73	85	95	116	134	150	164	190	212

Liters per Second

VALVE SIZE	Cv	AVAILABLE SIZING PRESSURE DIFFERENTIAL --- KPA											
		7	15	30	45	60	75	100	125	150	200	250	350
3/4"	6	0.4	0.6	0.8	1	1.1	1.2	1.4	1.6	1.8	2	2.3	2.7
1"	8.9	0.6	0.8	1.2	1.4	1.7	1.9	2.1	2.4	2.6	3	3.4	4
1-1/4"	16	1	1.5	2.1	2.6	3	3.3	3.8	4.3	4.7	5.4	6.1	7.2
1-1/2"	18	1.1	1.7	2.4	2.9	3.3	3.7	4.3	4.8	5.3	6.1	6.8	8.1
2"	30	1.9	2.8	3.9	4.8	5.6	6.2	7.2	8.1	8.8	10	11	13

BYPASS Applications - FULL FLOW thru UPPER Port (Bottom Closed)

Gallons Per Minute

VALVE SIZE	Cv	AVAILABLE SIZING PRESSURE DIFFERENTIAL --- PSI										
		2	4	6	8	10	15	20	25	30	40	50
3/4"	6	8.5	12	15	17	19	23	27	30	33	38	42
1"	11	16	22	27	31	35	43	49	55	60	70	78
1-1/4"	17	24	34	42	48	54	66	76	85	93	108	120
1-1/2"	24	34	48	59	68	76	93	107	120	131	152	170
2"	38	54	76	93	107	120	147	170	190	208	240	269

Liters per Second

VALVE SIZE	Cv	AVAILABLE SIZING PRESSURE DIFFERENTIAL --- KPA											
		7	15	30	45	60	75	100	125	150	200	250	350
3/4"	6	0.4	0.6	0.8	1	1.1	1.2	1.4	1.6	1.8	2	2.3	2.7
1"	11	0.7	1	1.4	1.8	2	2.3	2.6	3	3.2	3.7	4.2	4.9
1-1/4"	17	1.1	1.6	2.2	2.7	3.2	3.5	4.1	4.6	5	5.8	6.5	7.6
1-1/2"	24	1.5	2.2	3.2	3.9	4.5	5	5.8	6.4	7.1	8.2	9.1	11
2"	38	2.4	3.5	5	6.1	7.1	7.9	9.1	10	11	13	14	17

Product Identification

A red label should be on the front face of the thermal system.

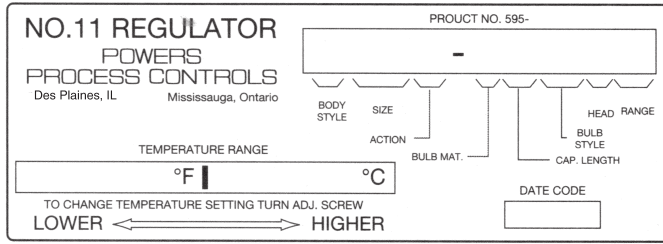

1. Product Label

Figure 1. This label contains information required to properly maintain, service and order parts for this product. If there is no label, look for a white label on the inside of the thermal system legs (Figure 2A) or the valve body vertical yoke (Figure 2B). When replacing the original thermal assembly or valve body, secure the old red label onto the valve or thermal system or ink the number onto the body.

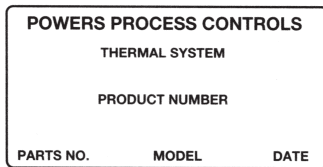

2A. Thermal System Label

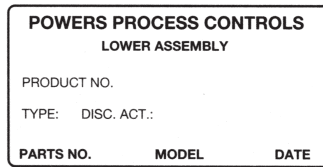

2B. Valve Body Label

Installation

Tools Needed

- Straight slot screwdriver
- 5/16" open end wrench
- 3/8" open end wrench
- 7/16" open end wrench
- 1-3/8" open end wrench
- Pliers
- 1/2" wrench for hi-power regulator housing bolts

Before Installing Valve

1. To insure proper system operation, thoroughly flush all piping and valves to rid them of all scale, dirt and debris.

Position Valve

2. Select valve location with sufficient clearance to allow maintenance. Install valve in line. The direction of the arrows on the valve body must match the direction of the water or steam flow.

For best results, we recommend installing the valve in a horizontal line, and in the upright position with bellows head above valve. The valve may also be installed in any position within 90° of upright.

3. **Figure 4.** The direction of the arrows on the valve body must match the direction of the water flow.

Pipe the hot water to the bottom 'B' port, and the cold water to the upper 'U' port. The mixed water will exit the valve through the common 'C' port.

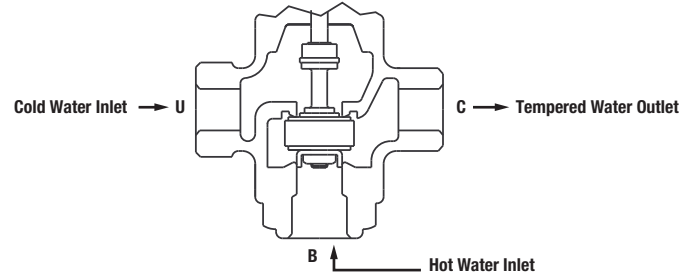

4. Inlet Piping

DO NOT reverse the inlets; the valve will not properly control the temperature of the mixed water if hot and cold supplies are reversed.

Install Bulb

4. Figure 5a shows proper bulb orientation. Figure 5b shows the special bulb needed for upwards vertical positioning.
5. Figure 6. For any position, fully immerse the bulb in the flow of the medium.

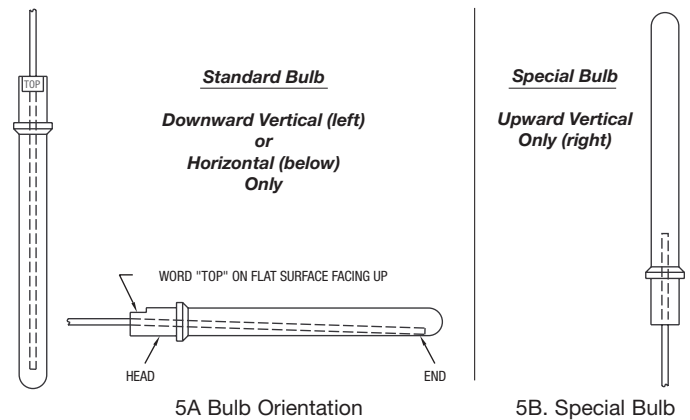

These instructions are for D style bulbs - for installation of other styles, refer to tag attached to bulb.

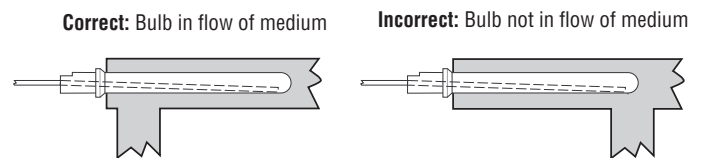

6. Bulb Position

- Without a well: Remove bushing from the bulb and screw it into the tank. Insert the thermostatic bulb through the bushing and tighten the union nut.

With a well: Do not use bushing. Screw well into tank, insert bulb directly into well, and tighten union nut.

Adjust Capillary Tubing

- Coil the extra capillary, and position away from regulator operation where it is subjected to room temperature only.

⚠ WARNING

DO NOT kink, cut, sever or file the tubing.
DO NOT disconnect tubing from bulb or bellows assembly. This can render the thermal system inoperable and result in severe process overheating.

Adjust Set Point

All regulators are factory set to control near mid-range operating temperature.

- When adjusting the set point, make certain all fluids are flowing through the valve and are at the operating pressure of the system.
- Figure 7. Make all set point temperature changes by inserting the temperature adjustment rod into one of the holes of the adjusting nut assembly. (Use the temperature adjustment setting scale only for reference)

To Raise the set point:

Turn rod left to right (counterclockwise from top).

To Lower the set point:

Turn rod right to left (clockwise from top).



Figure 7. Adjusting Set Point

Maintenance

Numbers in brackets [#] refer to part numbers on pp. 12 & 13.

To fully disassemble regulator from valve

- Before disassembly, the bulb **must be cooled** 30°F (16°C) below the lowest point on the thermal system range, and **flow through the valve must be stopped.**
- Figure 7. Relieve all pressure on the spring by turning adjusting nut assembly [31] fully right to left (clockwise from top).

- Figure 8.** Remove housing bolts [6] and nuts [7] and temperature adjustment setting scale [8] and lift off thermal system [1] (housing, bellows, capillary, and bulb).



8. Remove Housing and Thermal System

- Figure 9A.** For the 3/4" to 2" valves, use one 3/8" wrench and one 5/16" wrench, carefully loosen and remove piston plate assembly [2,3] from the stem extension [4]. Lift off spring [19].

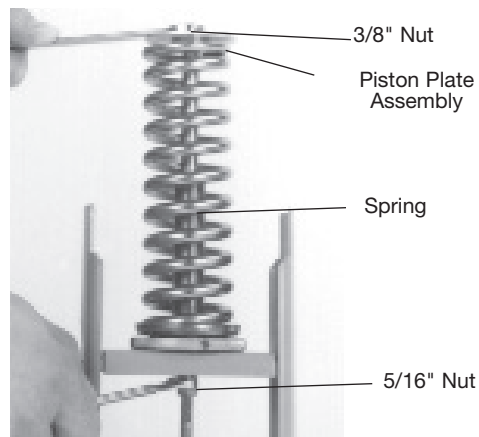

9A. (3/4" to 2") Remove Piston Plate and Spring

- Use a 1-3/8" wrench to unscrew lock nut [11].
Figure 10A. For the 3/4" to 2" valves, the bridge and yoke are a one-piece assembly [9]. Lift them off.

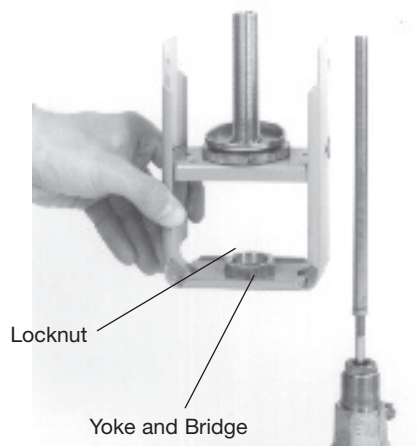

10A. (3/4" TO 2") Lift Off Bridge/Yoke Assembly

To replace valve plug, disks and gaskets

Follow steps 1-5, To fully disassemble regulator from valve. 6.

Figure 11. For all WM valve sizes, use the 3/8" wrench on the stem extension [4] and the 7/16" wrench on the hex nut [12] to loosen and remove them.

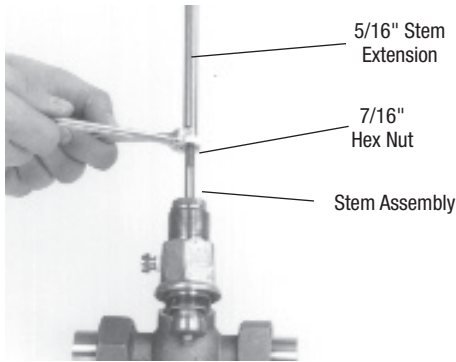

11. Remove stem extension and hex nut

6. Figure 12A. For 3/4" to 2" valves: Unscrew and remove valve seat [25]. Pull down valve plug assembly [23 & 24]. Remove disc lock nut, both disks and other parts [23a-e]. Replace with new discs and reassemble.

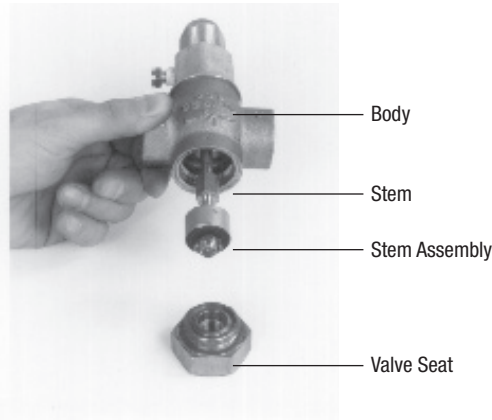

12A. (1/2" TO 2") Plug Assembly

To replace packing

Follow To fully disassemble regulator from valve steps 1-6.

- 7. Figure 11. Use a 5/16" wrench on the flats of the stem extension [4] and a 7/16" wrench on the hex nut [12] to loosen and remove them.
- 8. Use the 1-3/8" wrench to loosen and remove bonnet [20].
- 9. Carefully pull out stem assembly [30]. Check the stem. It must have a polished surface that is free of roughness and pitting. Replace any parts if necessary.
- 10. Figure 13. Remove packing gland [14], and all packing components [15a-15e].

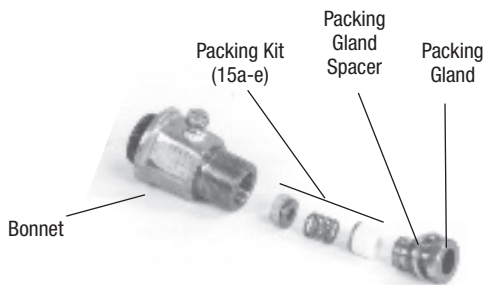

11. Packing Components

- 11. Clean packing chamber, taking care not to scratch seating surfaces. Be sure chamber is free of dirt and grease.
- 12. **For 1" - 2" valves**, place the upper gasket [21] on body before the bonnet.
- 13. Replace bonnet [20] and stem [30] into valve body.

NOTE: You must replace the bonnet and stem before attempting to insert the packing. Otherwise, you may tear the packing rings.

- 14. For standard packing kits, install the parts as shown in Figure 13.

Slide part(s) [15e], followed by [15d] and [15c] over the stem. Gently push them into the packing chamber.

NOTE: Some kits do not include all the listed packing parts (see page 12), but the order for part installation is the same.

- 15. **For EP V-rings**, lubricate the rings first.

Slide each V-ring [15b] over the stem and carefully push it into the packing chamber.

- 16. Place the packing gland spacer [15a] on top of the bonnet.
- 17. Thread the packing gland assembly [14] into the bonnet. Tighten the gland assembly against the spacer.

- 18. **With stem in full UP position** (the valve plug firmly seated), screw stem extension [4] to the dimension shown in Figure 14 and tighten into place with hex nut [12].

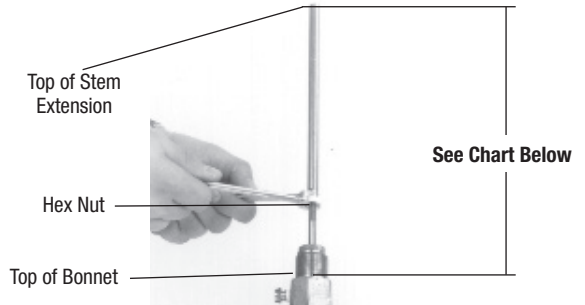

14. Stem Extension Reassembly Dimension

STEM SETTING DIMENSION (SEE ABOVE)	
Valve Size	
3/4" to 2"	
	10-1/16" (+1/32, -0)
	[256mm (+.79, -0)]

- 19. Make sure the valve stem is in the full up position when replacing the spring seat and piston plate assembly on the large valves.
- 20. Assemble the remaining parts in reverse order.

Testing the Thermal System

1. Stop the flow of fluid through the line.
2. Raise the temperature of the bulb above the set point temperature by placing it in a container of hot water. This will cause the plug to fully seat.
3. Figure 15. With the valve plug seated in the bottom port "B," use a felt tip pen to mark the position of the packing gland assembly on the stem.

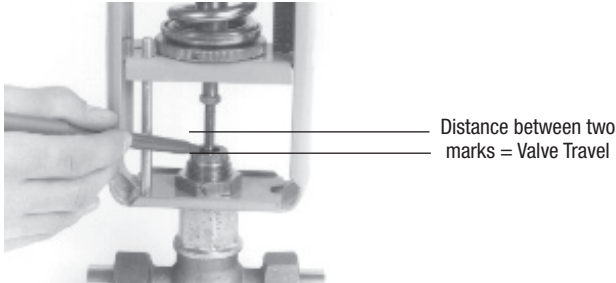

15. Valve travel measurement

4. Place the bulb in a pan of cool water. Cool the bulb 30°F (16°C) below set point so the valve is fully open.
5. With the valve plug now seated on the upper port "U," use the pen to mark the new position of the packing gland assembly on the stem.
6. The distance between the marks is the valve plug travel. This should correspond with the TRAVEL value in the VALVE DIMENSIONS table on page 10. **No movement or only partial movement indicates the thermal system is defective and should be replaced with a new system.**

Preventive Maintenance

Once every three months, inspect the Regulator as follows:

1. Visually check for leaks from the valve body joints, piping-to-valve connections, packing and stem areas.
2. Visually check for excessive corrosion on the regulator, including the bellows, capillary, bulb, thermal system legs, bridge, and yoke. Also check for excessive corrosion on the valve body.
3. Perform the instructions in **Testing the Thermal System**. Less than full valve travel may indicate a leak in the bellows, capillary, or bulb, or other problems. This may result in excessive temperature in the process.
4. Test the temperature adjusting nut assembly for freedom of movement (see **Adjust Set Point** for instructions).
5. Remove bulb from the process fluid and check for excessive corrosion, or erosion that may weaken the bulb and/or cause thermal system failure.

Troubleshooting

⚠ WARNING

Failure of the thermal system will result in a constant rise in temperature (or constant high temperature) of the fluid which you are trying to control.

• Erratic temperature control (valve cycles too hot/too cold)

1. Highly fluctuating supply pressures.
2. Sticking stem caused by packing gland assembly too tight, locking valve stem. Loosen packing gland assembly and lubricate if desired.
3. Sticking stem caused by bent valve stem or valve stem not properly lubricated. Refer to Maintenance for replacement.
4. Valve sized incorrectly. Verify valve selection.
5. Regulator is controlling at incorrect set point. Refer to **Adjust Set Point**.
6. Bulb is poorly positioned and/or oriented, and will not control the actual temperature of the heating/cooling medium. Refer to **Install Bulb**.
7. Incorrect type of bulb is being used. See Table on page 11.

• Temperature of discharge water too low

1. Temperature adjusting nut assembly set too low. Refer to **Adjust Set Point**.
2. A radical drop in the hot water supply temperature or pressure. Check supply waters.
3. Valve cannot close against cold inlet. Foreign material may be caught between the disc and the valve plug seat. Refer to **Replacing the composition disc** for disassembly. Clean.

• Temperature of discharge water too high

1. Temperature adjusting nut assembly set too high. Refer to **Adjusting Set Point**.
2. Thermal system failure. Refer to **Testing the Thermal System**.
3. Incorrect piping to valve. Refer to Operation and/or Installation.
4. Bulb is poorly positioned and/or oriented, and will not control the actual temperature of the heating/cooling medium. Refer to **Install Bulb**.
5. Incorrect type of bulb is being used. See Table on page 11.
6. Pressure differential is greater than allowable pressure drop. Refer to **Water Mixing Capacities tables**.
7. Disc is worn. Replace disc (refer to **Maintenance**).
8. Valve cannot close against hot inlet. Foreign material may be between the disc and the valve plug seat. Refer to **Replacing the composition disc** for disassembly. Clean.
9. Packing gland assembly is too tight, locking valve stem. Loosen packing gland assembly and lubricate if desired.
10. Bent valve stem; need to replace. Refer to **Maintenance** for disassembly instructions.

• Chattering of Valve

1. Regulator installed with the flow of the control medium in reverse of arrow direction on valve body.
2. Pressure differential too high, refer to **Water Mixing Capacities tables** for correct pressure differential range.

• Constant rise in mixed water temperature

1. A constant rise in temperature may indicate the thermal system is leaking charge and/or the valve has failed with the port for Hot water fully or partially open.

Dimensions

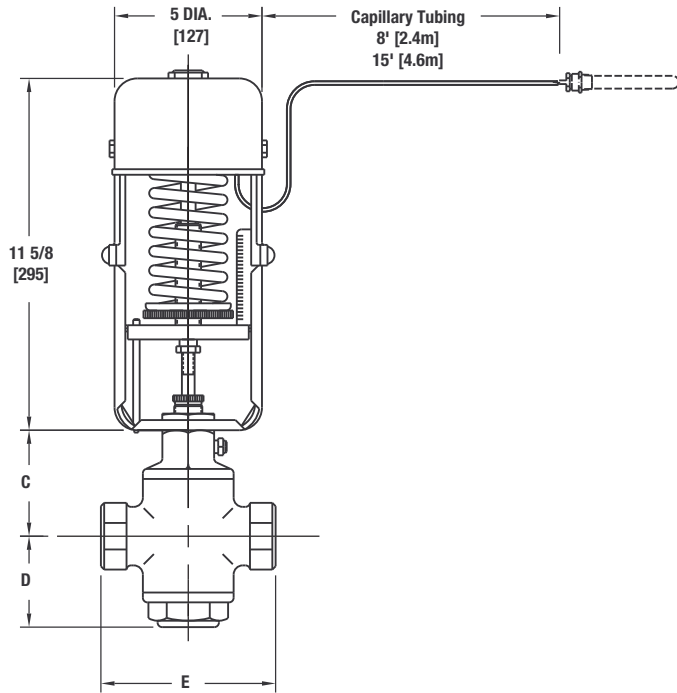

3/4" to 2" Screwed Bodies

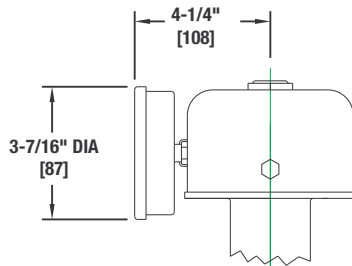

Optional Indicating Style

Valve Dimensions

STYLE	VALVE SIZE	C (IN)	D (IN)	E (IN)	TRAVEL (IN)	ACTUAL WEIGHT (LBS.)	
						NON INDIC.	INDICATING
Screwed Ends	3/4"	2 5/8	2 1/4	3 3/8	3/16	20	22
	1"	2 3/4	2 1/2	3 7/8	1/4	21	23
	1-1/4"	3	2 3/4	4 1/2	5/16	23	25
	1-1/2"	3 1/4	3	5 1/8	5/16	26	28
	2"	3 5/8	3 3/8	6 1/8	5/16	31	33

STYLE	VALVE SIZE	C (MM)	D (MM)	E (MM)	TRAVEL (MM)	ACTUAL WEIGHT (KG.)	
						NON INDIC.	INDICATING
Screwed Ends	3/4"	67	57	86	5	9.1	10
	1"	70	64	98	6	9.5	10.4
	1-1/4"	76	70	114	8	10.4	11.3
	1-1/2"	83	76	130	8	11.8	12.7
	2"	92	86	156	8	14.1	15

Bulb Dimensions

					TANK FTG. NPT	MAX. PRESSURE - PSI	
BULB	STYLE	SIZE	MATERIAL	A (IN)	B (IN)	SHOCK	NON-SHOCK
D Fixed Union (& V-Vertical Fixed Union)	1 x 9	Copper	15/16	8	1"	175	250
		347 Stainless	15/16	8 1/16	1"	500	725
	1 x 20	Copper	15/16	19 7/8	1"	175	250
		347 Stainless	15/16	19 13/16	1"	500	725
	1-1/4 x 24	Copper	1 3/16	22 11/16	1-1/4"	150	200
J Plain Bulb*	1 x 9	347 Stainless	15/16	8 3/4	-	-	-
		Teflon Coated	15/16	8 3/4	-	-	-
	1 x 20	347 Stainless	15/16	20 1/2	-	-	-
		Teflon Coated	15/16	20 1/2	-	-	-
JD Adjustable	1 x 9	347 Stainless	15/16	8 3/4	1"	500	725
	1 x 20	347 Stainless	15/16	20 1/2	1"	500	725

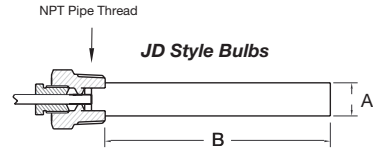
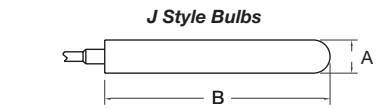
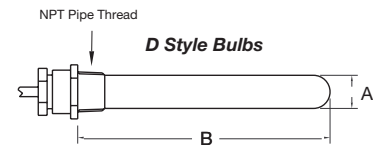

					TANK FTG. NPT	MAX. PRESSURE - PSI	
BULB	STYLE	SIZE	MATERIAL	A (MM)	B (MM)	SHOCK	NON-SHOCK
D Fixed Union (& V-Vertical Fixed Union)	1 x 9	Copper	24	203	1"	4445	6350
		347 Stainless	24	205	1"	12700	18415
	1 x 20	Copper	24	505	1"	4445	6350
		347 Stainless	24	503	1"	12700	18415
J Plain Bulb*	1 x 9	347 Stainless	24	222	-	-	-
		Teflon Coated	24	222	-	-	-
	1 x 20	347 Stainless	24	521	-	-	-
		Teflon Coated	24	521	-	-	-
JD Adjustable	1 x 9	347 Stainless	24	222	1"	12700	18415
	1 x 20	347 Stainless	24	521	1"	12700	18415

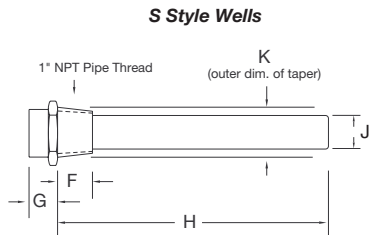
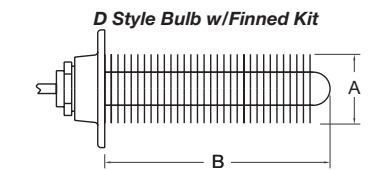

Well Dimensions

								TANK FTG. MAX.	WELL PRESSURE - PSI	
BULB SIZE	WELL KIT #	WELL MATERIAL	F (IN)	G (IN)	H (IN)	J (IN)	K (IN)	NPT	SHOCK	NON-SHOCK
1 x 9	709 193	Chrome Plated Copper	15/16	13/16	9 1/16	1	1.11	1"	175	250
	808 478	316L Stainless Steel	1 1/16	13/16	8 11/16	1 1/64	1.11	1"	450	675
	808 476	Carbon Steel	1	1 13/16	7 11/16	1 1/8	1.125	1"	1000	1500
1 x 20	709 075	Chrome Plated Copper	15/16	13/16	21 1/16	1	1.11	1"	175	250
	808 475	316L Stainless Steel	1 1/16	13/16	20 3/8	1 1/64	1.11	1"	450	675

								TANK FTG. MAX.	WELL PRESSURE - PSI	
BULB SIZE	WELL KIT #	WELL MATERIAL	F (MM)	G (MM)	H (MM)	J (MM)	K (MM)	NPT	SHOCK	NON-SHOCK
1 x 9	709 193	Chrome Plated Copper	24	21	230	25	28	1"	1207	1724
	808 478	316L Stainless Steel	27	21	221	26	28	1"	3103	4654
	808 476	Carbon Steel	25	46	195	29	29	1"	6895	10342
1 x 20	709 075	Chrome Plated Copper	24	21	535	25	28	1"	1207	1724
	808 475	316L Stainless Steel	27	21	518	26	28	1"	3103	4654

Parts List

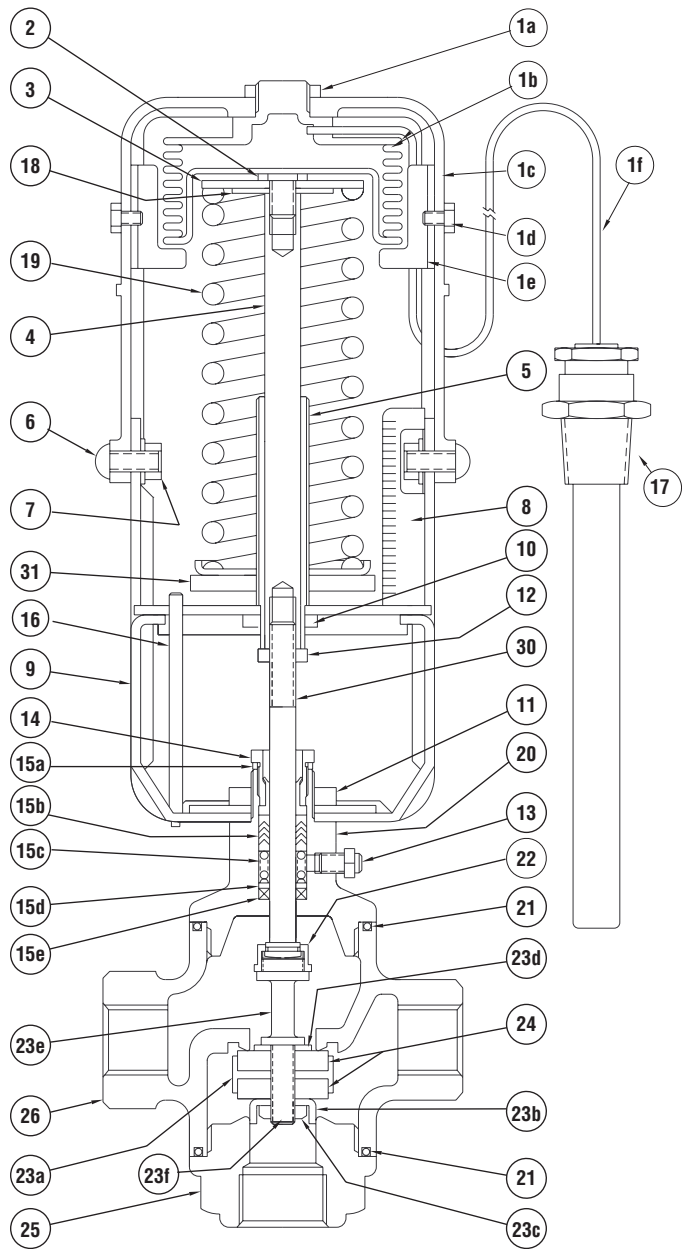

3/4" - 2" WM Assemblies

Parts

ITEM	DESCRIPTION	VALVE BODY SIZE					QTY	MATERIAL
		3/4"	1"	1-1/4"	1-1/2"	2"		
1	Thermal System						1	–
1a	Locknut			Not sold as separate part - refer to Thermal System			–	–
1b	Thermal Motor/Bellows			Not sold as separate part - refer to Thermal System			2	–
1c	Housing			Not sold as separate part - refer to Thermal System			1	–
1d	Screw			Not sold as separate part - refer to Thermal System			2	–
1e	Bellows Stop			Not sold as separate part - refer to Thermal System			2	–
1f	Bulb/Capillary Assembly			Not sold as separate part - refer to Thermal System			1	–
2	Piston Plate Retaining Screw			590 816			1	SS
3	Piston Plate Washer			590 815			1	Zn plate Steel
3	Piston Plate/Shank Assembly			–				–
4	Stem Extension			590808B				Brass
5	Spring Adjustment Screw			590 807			1	Brass
6	Screw			030546J			2	Zn plate Steel
6	Bolt			–			2	Zn plate Steel
7	Hex Nut 5/16 x 18			041225K			2	Cd plated Steel
8	Temp. Adj. Setting Scale			590 813			1	Aluminum
–	Lower Housing Assembly			590 859				–
9	Yoke/Bridge Assembly			594 515			1	–
9A	Bridge			–				–
9B	Yoke			–				–
10	Nut, hex			041167J			1	Zn plate Steel
11	Nut, hex			041 125				Brass
12	Locknut			628 008			1	Brass
12	Locknut			–				Zn plate Steel
13	Pipe Plug			403 007				Brass
13	Stem Lubricator Kit			590184A				–
14	Packing Gland Assembly			590 763				Brass
15	Packing Kit			See Kits on page 14				–
15a	Packing Spacer			“			1	–
15b	Packing Set			“			1	–
15c	Packing Spring			“			1	–
15d	Packing Washer			“			1	–
15e	Packing Ring			“			1	–
16	Temp. Adjusting Rod			590 820				Cd plated Steel
17	1" NPT Tank Fitting			705 005				Brass
17	1-1/4" NPT Tank Fitting			705 006				Bronze
18	Spring Guide Washer			590 814			1	Steel
18	Spring Seat			–				Brass
19	Spring	590 821	–	–	–	–	1	Zn plate Steel
19	Spring, inner	–	595 501	595 501	595 501	595 501	1	Zn plate Steel
19	Spring, outer	–	595 502	595 502	595 502	595 502	1	Zn plate Steel
19	Spring	–						Chr. Si Steel
20	Bonnet Assembly	590 134	590 137	590 140	590 143	590 146		Brass
21	Gasket	–	084 008	084 016	084 009	084 010	2	Silicone
21	Gasket	–						Gasket Material
22	Stem Head Retainer	708 036	654 016	654 016	603 012	603 012		416 Stainless
23-24	Disc Assembly	590 779	590 743	590 690	590 691	590 692	1	Brass
23a	Disc Holder	“	“	“	“	“	1	Brass
23b	Disc Guide	“	“	“	“	“	1	Brass
23c	Thrust Collar	“	“	“	“	“	1	Brass
23d	Washer	“	“	“	“	“	1	Brass
23e	Stem Extension	“	“	“	“	“	1	Brass
23f	Disc Sleeve	“	“	“	“	“	1	Brass
24	Disc	“	“	“	“	“	2	Garlock
24	Throttling Disc							Bronze
25	Valve Seat	590 748	594 513	590 684	594 475	594 459	1	Bronze
26	Valve Body Assembly	115 072	115 073	115 074	115 069	115 070	1	Bronze
26	Valve Body & Seat Assembly	–						Bronze
27	Valve Flange & Seat Assy.	–						Brass
28	Cap Screws	–						Brass
30	Stem Assembly	594813A	593815A	593815A	594816E	594816E		–
31	Temp. Adj. Nut Assembly							–

Accessories

KIT#	MATERIAL	VALVE SIZE	STEM SIZE	USAGE	PARTS	LUBRICANT
591 927	Teflon V-ring	3/4" - 2"	1/4"	Effective from 200°F-400°F S team: 50 - 200 psi	15A, 15B, 15C, 15D, 15E	None
594 220	EP V-ring	3/4" - 2"	1/4"	Effective from 0°F-300°F Steam: 50 PSI maximum Water: up to maximum PSI valve rating	15A, 15B, 15C, 15D, 15E	Silicone required for installation (optional for service)
594 289	TFE Split Ring	3/4" - 2"	1/4"	For replacement only Effective from 40°F-366°F	15B, 15D	Silicone Part #087 126

Temperature Ranges/Bulb Sizes

For ordering thermal systems, refer to order code, the Powers #11 Product Specification Brochure, or call Powers.

BULB SIZE	BULB TEMP. RANGE	ORDER CODE
	1/2" TO 2"	
	WATER MIX	
1" x 20"	10–60°F (-12–16°C)	01
	55–115°F (12–46°C)	02
	80–140°F (27–60°C)	03
	100–160°F (37–71°C)	04
1" x 9"	110–160°F (43–71°C)	05
	135–195°F (57–91°C)	07
	160–220°F (71–104°C)	08
	200–250°F (93–121°C)	09
	230–280°F (110–138°C)	10
	260–320°F (127–160°C)	11

Order Code

Valve Assembly Thermal System Assembly

595-

Valves Type WM
3-Way Water Mix

Valve Sizes
3/4" (20mm)075
1" (25mm) 100
1-1/4" (32mm)125
1-1/2" (40mm)150
2" (50mm)200

Applications
Mixing M

Bulb/Capillary Material & Length
Copper 8' C08
Copper 15' C15
Copper 30' C30
Stainless Steel 8' S08
Stainless Steel 15' S15
Stainless Steel 30' S30

Bulb Size
Fixed Union D
No Pipe Fittings (N/A Copper) J
Adj. Union (N/A in H head) A
Fixed Union (D Type) VerticalV

Head Assembly
Non-indicating N
Indicating I

Range/Bulb Size
See chart on page 13.##
Select Range with Set Point in
UPPER THIRD for best performance.

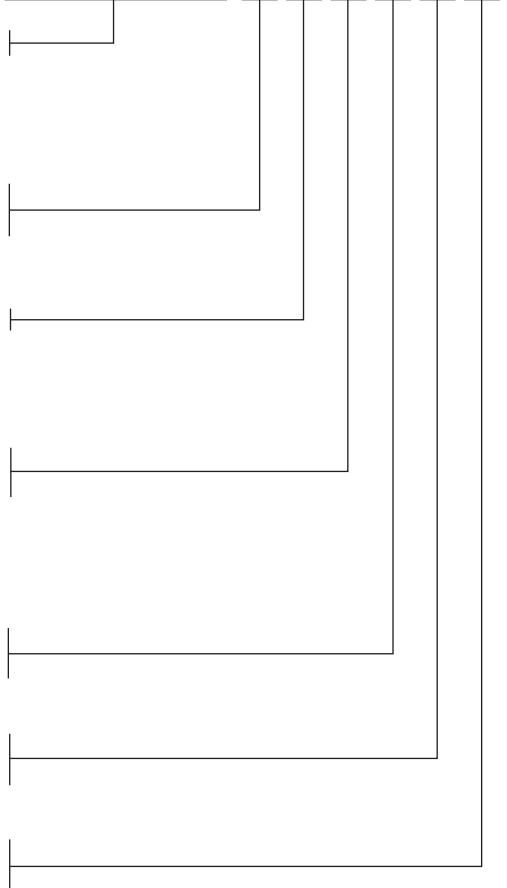

The Seller warrants that the equipment manufactured by it and covered by this order or contract is free from defects in material and workmanship and, without charge, equipment found to be defective in material or workmanship will be repaired, or at Seller's option replaced F.O.B. original point of shipment, if written notice of failure is received by Seller within one (1) year after date of shipment (unless specifically noted elsewhere), provided said equipment has been properly installed, operated in accordance with the Seller's instructions, and provided such defects are not due to abuse or decomposition by chemical or galvanic action. THIS EXPRESS WARRANTY IS IN LIEU OF AND EXCLUDES ALL OTHER WARRANTIES, GUARANTEES, OR REPRESENTATIONS, EXPRESS OR IMPLIED. THERE ARE NO IMPLIED WARRANTIES OF MERCHANTABILITY OR OF FITNESS FOR A PARTICULAR PURPOSE. The Seller assumes no responsibility for repairs made on the Seller's equipment unless done by the Seller's authorized personnel, or by written authority from the Seller. The Seller makes no guarantee with respect to material not manufactured by it.

POWERS™

A WATTS Brand

USA: T: (800) 669-5430 • F: (847) 229-0526 • PowersControls.com
Canada: T: (905) 332-4090 • F: (905) 332-7068 • PowersControls.ca
Latin America: T: ((52) 55-4122-0138 • PowersControls.com