

POWERS™

TECHNICAL INSTRUCTIONS

HYDROPANEL™ II SHOWER SYSTEM

with Biltmore 900 Model 3 Pressure Balancing Valve

DESCRIPTION

The Powers Hydropanel II Shower System with Biltmore 900 Valve combines pressure balanced water control with the convenience of modular shrouding. Hydropanel II stainless steel shrouding provides a concealed shower system where in-wall piping does not exist or may not be practical. The Biltmore 900 valve uses a proven poppet/diaphragm cartridge to balance hot and cold water supply pressures and deliver water to the shower at a user-selected temperature. The balancing cartridge and poppets, and wide seat clearance in the valve provide maximum protection against lime and dirt build up. The valve opens in the cold position and features a handle rotation stop to guard over adjustment of the handle.

The Series 4504000 Hydropanel II comes complete with the stainless steel Hydropanel II Shrouding, Series 900 Biltmore valve with checkstops, piping, showerhead, end cap and mounting hardware. Some models feature a stainless steel soapdish. An optional handshower comes preassembled with a full spray pushbutton handshower, 60" hose, 18" mounted glide-bar and connectors. The Biltmore 900 valve is CSA/ASSE approved and the Series 4504000 Hydropanel II units carry a two-year limited warranty.

The following instructions serve as guide for installation, general maintenance and parts replacement for Hydropanel II Shower Systems with Biltmore 900 Pressure Balancing Valves. For detailed repair and maintenance instructions for the Biltmore 900 valve or integral checkstops, please refer to Form #TI 900. For specification or installation of the Hydropanel II Modular Shrouding for shower rooms, please refer to Forms #PS 450SH and #TI 450SH.

OPERATION

Hot and cold water enter respective chambers in the valve. A diaphragm/poppet assembly floats between these chambers and balances the supply water pressures. The chamber/balancing assembly is replaceable as a complete cartridge. Any change in supply pressure moves the diaphragm/poppet assembly to equalize the supply water ratios and minimize the shower temperature disturbance.

A mixing plate separates the balancing chambers from the mixing chamber. When the adjustment handle is in its full clockwise position (OFF), the mixing plate closes both supply chambers. As the valve handle rotates toward the stop, hot and cold supply water pass through slots in the mixing plate in proportions required to produce the user selected temperature. Tempered water exits the valve and passes to the showerhead.

A limit stop limits the movement of the control handle toward the full hot position. The Biltmore 900 does not compensate for supply water temperature changes, so any variation in the supply temperatures will affect the control point temperature.

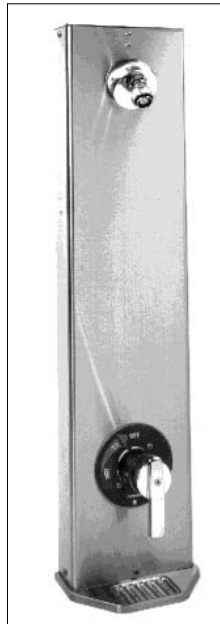

*Hydropanel II
Model 4504002 with
Swivel Showerhead
and Soapdish*

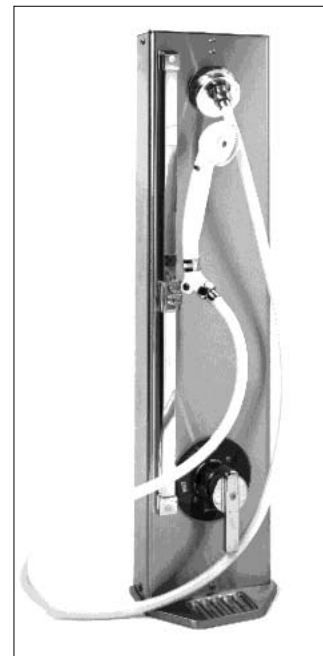

*Hydropanel II
Model 4504004 with
Handshower Assembly
and Soapdish*

SPECIFICATIONS

Hydropanel: Brushed 18 Gauge 304 SS. Dimensions 31-1/8"H x 7-1/2"W x 6"D [791mm H x 191mm W x 154mm D].

Piping: 1/2" copper tubing.

Showerhead: Fixed: Chrome plated brass, maximum flow 2.5 gpm @ 80psi [0.16 l/s @ 552 kPa]. Adjustable Swivel: Chrome plated brass, 30° angle of rotation, maximum flow 2.5 gpm @ 80psi [0.16 l/s @ 552 kPa].

Valve Assembly and Trim: Biltmore 900 Pressure Balancing Valve. Four port (bottom outlet plugged), cast brass body with chrome plated zinc lever handle. 1/2" sweat inlet/outlet connections. Standard integral checkstops. Standard handle rotation stop.

Valve Operation: 4.6 gpm @ 45psi differential [0.25 l/s @ 310 kPa]. Maximum pressure (static) 125psig [862 kPa]. Maximum inlet temperature 180°F [82°C].

Handshower: Full spray with pushbutton water control. Minimum flow 2.0 gpm @ 20 psi [0.13 l/s @ 138 kPa]. Maximum flow 2.5 gpm @ 80psi [0.16 l/s @ 138 kPa]. 1/2" chrome finished supply connections. 24" [610mm] chrome finished brass glide bar, self-tensioned for easy height adjustment. Professional model: 60" [1499mm] reinforced vinyl hose. Deluxe Model: 60" [1499mm] metal spiral hose.

INSTALLATION

Before installation of any Hydropanel II unit, rotate the stem (or handle if attached) of the valve to its full clockwise position (OFF).

POSITION THE HYDRO PANEL II UNIT

(See Figures 1 and 2) Determine the horizontal position of the unit according to shower room layout, and mark the centerline. For multiple shower applications, the recommended minimum distance between the centerline of two units is 36" [1914mm].

small holes in the wall 23-1/2" [587mm] below the showerhead on the centerline.

7. Install any mounting anchors as detailed by the individual room specifications.
8. Secure upper piping bracket B with mounting screws (not included).
9. Secure lower piping bracket C with mounting screw (not included).

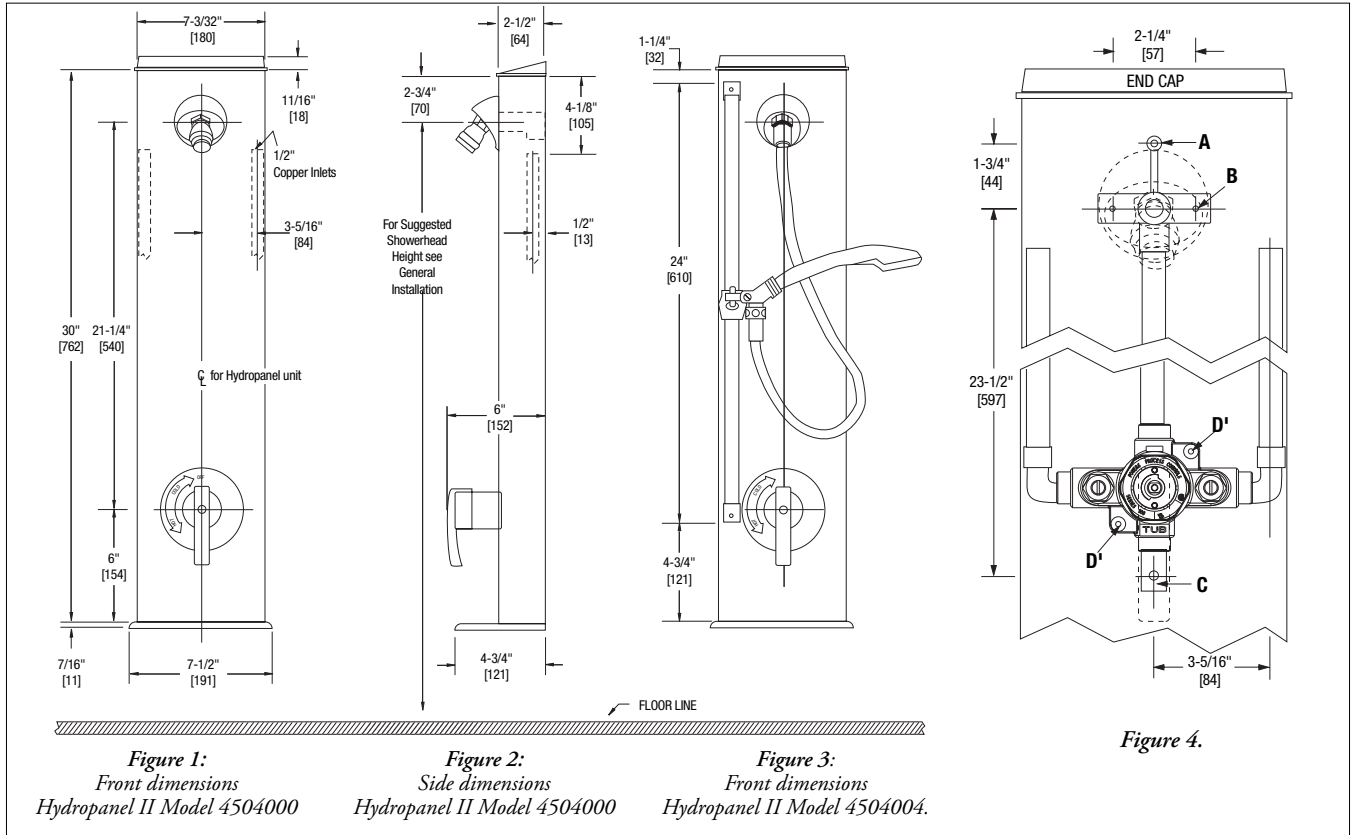

1. Determine the floor-to-showerhead height for the unit. Recommended heights are listed below:
 Men - 77" [1956mm] Youth - 66" [1676mm]
 Women - 70" [1778mm] Youth - 60" [1524mm]
2. The preassembled copper tubing supply water inlets are 4-1/8" [105 mm] from the top of the shroud, and 3-5/16" [84mm] left and right of the centerline. Adjust supply piping accordingly.

Install the Piping Assembly

The valve handle assembly, piping and Hydropanel II shrouding must be separated before mounting to wall. For #4504004 and #4504005 Hydropanel II units, the handshower, hose and showerhead base come preassembled to the shrouding. Refer to Figure 4.

3. Detach the valve assembly by removing valve retaining screw, handle and collar. Undo the screws at D and D' and take off the dial insert.
4. Remove the screw at A above the showerhead. Slide the piping out of the shrouding; the shower head remains attached to the shroud.
5. For mounting the piping assembly upper bracket (B), use the bracket as a template and drill two small holes in the wall at showerhead height.
6. For mounting the piping assembly lower bracket (C), drill one

10. Connect the supply lines to the piping assembly.

Attach the Shrouding

Do Not remove the entire chrome plated end cap from the shrouding; it functions as an end cap and gasket for shroud extension. Part of the end cap can be broken out to provide vertical and horizontal piping clearance.

10. To remove scored section, hit it sharply with a hammer.
11. To connect the showerhead on the shroud to the water outlet pipe, slide the showerhead nipple on the inside of the shroud into the piping assembly. The End Cap will slide over the supply piping. Secure the shrouding with the screw at A.

Test the System

Before final assembly, test the Hydropanel II system.

12. Fit the handle onto the valve stem and turn clockwise to the shut off position.
13. Turn on water supply, and then rotate the valve handle counterclockwise. Water should come through the showerhead.
14. Now turn handle fully counterclockwise and measure the temperature of the outlet water. Wait until the temperature stabilizes for an accurate reading.
15. Turn off valve (fully clockwise) and check all connections (showerhead, pipe connections, valve bonnet) for leaks.

INSTALLATION, CONTINUED

Set the Limit Stop

The Biltmore 900 is a pressure balancing valve, and therefore cannot compensate for variations in hot water supply temperatures. It is factory set to pass full hot water.

The handle rotation setting must be adjusted to limit the distance the user can rotate the handle towards the full hot water position.

CAUTION: Any repair or modification of the valve will affect the high temperature setting. Any changes in inlet water temperature will require readjustment of the limit stop.

Maximum temperature setting must be set at the job site. High temperature limit stop is located on the bonnet. Refer to Figure 5.

16. Remove O-ring and discard.
17. Slide the retainer and the high temperature limit stop out. Rotate stem to desired maximum temperature, but no greater than 115°F (46°C). Slide back the maximum temperature limit stop touching the tab on the stem.
18. Slide the retainer back all the way to secure the high temperature limit stop. Install handle.
19. Replace handle. Repeat steps 12 through 18 until desired maximum outlet temperature is reached. Remove handle before final assembly of shrouding.

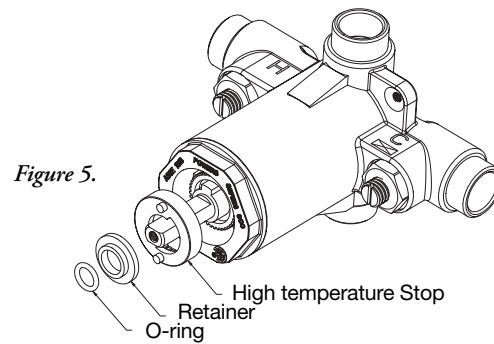

Assemble the Valve Cover and Handle

20. (Figure 4) Fit the dial insert onto the shrouding and secure to the shroud and valve at D and D' with the 2-1/4" screws.
21. Slide the O-ring and sleeve over the bonnet. Place the lever over the stem, and secure with retaining screw using the supplied wrench.
22. (Figure 4) Finish assembly by tightening the shrouding screw at A above the showerhead.

SERVICING THE HYDROPANEL UNIT

Before servicing checkstops or piping, turn off the supply water upstream. To access the checkstops, remove the valve handle assembly, cover plate and shrouding (refer to **Install the Piping Assembly**).

At least every twelve months, open up the checkstops and check for free movement of the poppet.

Before servicing the valve, either turn off the water supply upstream (the shroud does not have to be removed), OR access

and close the checkstops. To close the checkstops, turn the adjustment screw on each fully clockwise.

Every month, check and adjust the handle rotation setting. Every twelve months, remove the valve bonnet and check the internal components for freedom of movement.

To service or clean the showerhead, unscrew from shroud at hex nut. Service as necessary, and reattach.

TROUBLESHOOTING

***NOTE:** For complete technical instructions on servicing the Biltmore 900 valve or integral checkstops, please refer to Form #TI 900.

1. If the flow of water is less than desired...

- a. The upstream supply valves may not be fully open.
- b. The inlet supply pressure(s) may be low.
- c. Lime deposits may have accumulated in the hot water pipes, restricting water flow.
- d. The showerhead may be clogged. Remove according to Servicing the Hydropanel II Unit and clean.
- e. The checkstops may be clogged.

2. If the flow of water is completely shut off...

- a. The upstream supply valves may be completely closed.
- b. The hot or cold water supply pressure may have failed. The Biltmore 900 valve is designed to virtually shut off in the event of hot or cold supply water failure.
- c. The checkstops may be closed. Access the checkstops and open by turning the adjustment screw fully counterclockwise.

3. If the water flowing from the showerhead varies in temperature, or is untempered hot or cold...

- a. The diaphragm inside the balancing chamber may have failed. Replace with Repair Kit #900 032.
- b. The hot water supply temperature may be too low.

4. If water continues to flow from the showerhead after shut off, or the valve leaks at the stem and/or bonnet...

- a. The shut-off discs or gaskets in the valve may have worn out. Replace with Repair Kit #900 028.
- b. The mixing plate may be damaged. Replace with Repair Kit #900 032.
- c. Inlet O-rings may be damaged.

5. If the checkstops leak, or they won't shut off...

- a. The checkstops may be damaged. Clean and service with Repair Kit #900 050.

6. If a maximum temperature cannot be obtained...

- a. Lime deposits may have accumulated in the hot water pipes, restricting the hot water supply.
- b. The hot water supply temperature may be too low.
- c. The handle rotation setting may be too low. Remove valve handle, and readjust the limit stop (see Setting the Limit Stop).
- d. The diaphragm assembly may have failed. Replace with Repair Kit #900 032.

7. If the valve opens with hot water flow rather than cold water flow...

- a. The supply water inlets may be reversed, or the mixing plate orientation may be incorrect. Refer to Figure 6.
 - 1) Turn the valve handle to full clockwise position (OFF).

TROUBLESHOOTING, CONTINUED

- 2) Turn off supply water and access the valve.
- 3) Check that the adjustment stem faces the correct direction for valve operation: Refer to *Figure 6*.
 - For **NORMAL** operation, Hot Inlet is on the left and Cold Inlet is on the right. With the valve in shut off position, the flats on the stem face the top and bottom outlets, and **TOP** stamped on stem faces shower outlet.
 - For **REVERSE** valve operation, Cold Inlet is on the right and Hot Inlet is on the left. With the valve in shut off position, the flats on the stem face the top and bottom outlets, and **TOP** stamped on stem faces **DOWN**.
- 4) Remove handle. Remove limit stop and bonnet. Turn the stem 180° so the word **TOP** faces the appropriate direction. Replace bonnet and limit stop.
- 6) Replace handle. Test the system. Replace shroud, sleeve, and valve handle.

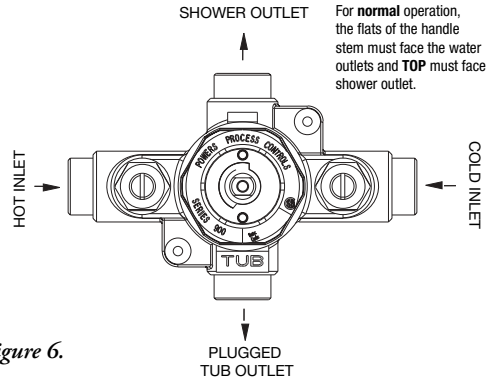

Figure 6.

ORDERING

#	Part #	Description	Qty	Material
1	N/A	Shroud	1	St Steel
4	450 268	Soap Dish	1	St Steel
5	4504011	End Cap Kit	1	Chrm Plt ABS
6	450 273	Screw 10-32 x 3/8 (shrouding)	7	St Steel
NS	141 318	Handshower with 24" Glidebar	1	-
7	450 276	Set Screw 10-32 x 7/8	1	St Steel
8	141 816	Fixed Showerhead	1	Chrm Plt Brass
9	141 379	Swivel Showerhead	1	Chrm Plt Brass
10	450 277	Gasket, Showerhead Base	1	Garlock 3000
11	4502676	Showerhead Base	1	Chrm Plt Brass
12	047 013	Quad Ring 3/8 x 1/2 x 1/16	1	Buna N
13	450 274	Screw 10-32 x 1/4 (showerhead)	3	Brass
15	450 271	Screw 8-32 x 1/2 (valve handle)	1	St Steel
16	900 036	Handle Lever Kit	1	Chrm Plt Znc
17	800015H	Sleeve	1	Chrm Plt Brass
17A	084 041	O-Ring	1	Buna-A
24	450 272	Screw 8-32 x 2-1/4 (dial insert)	2	St Steel
25	450 270	Insert Dial	1	Al w/Mylar
32	N/A	Hydroguard /Piping Assembly	1	-
NS	089 003	3/32" Service Wrench	1	Steel
NS	089 004	1/8" Service Wrench	1	Steel

NS = Not shown in diagram

NA = Not available as commercial part

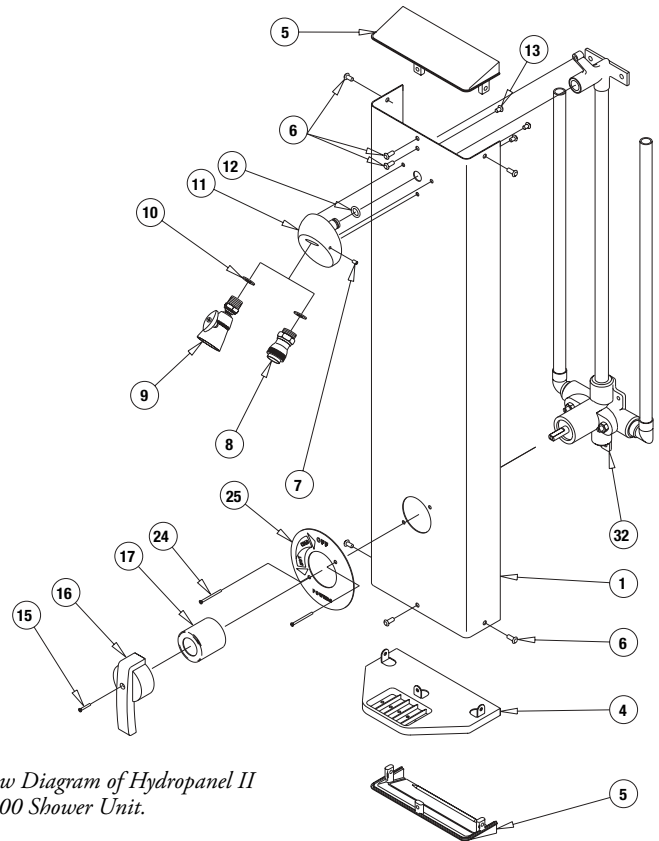

Exploded View Diagram of Hydropanel II Series 4504000 Shower Unit.

CALIFORNIA PROPOSITION 65 WARNING

WARNING: This product contains chemicals known to the State of California to cause cancer and birth defects or other reproductive harm. (California law requires this warning to be given to customers in the State of California.)

For more information: www.watts.com/prop65

POWERS™
a division of Watts Water Technologies, Inc.

© 2006 Powers

USA: Phone: 1.800.669.5430 • Fax 1.847.229.0526 • www.powerscontrols.com
Canada: Phone: 1.888.208.8927 • Fax 1.888.882.1979 • www.powerscontrols.com