



TWO-WAY FLOW ALTITUDE VALVE

03/06

960 Series

—Model— **960-17**
660-17

- Designed for Tank Fill and Discharge applications
- Opens when Tank head pressure is below setpoint
- Closes when Tank head pressure is above setpoint
- Opens for return flow when upstream system pressure is below Tank head pressure
- Tank Sense Line is field installed (to Tank or standpipe)
- Adjustable Opening and Closing Speed
- Altitude setpoint is adjustable

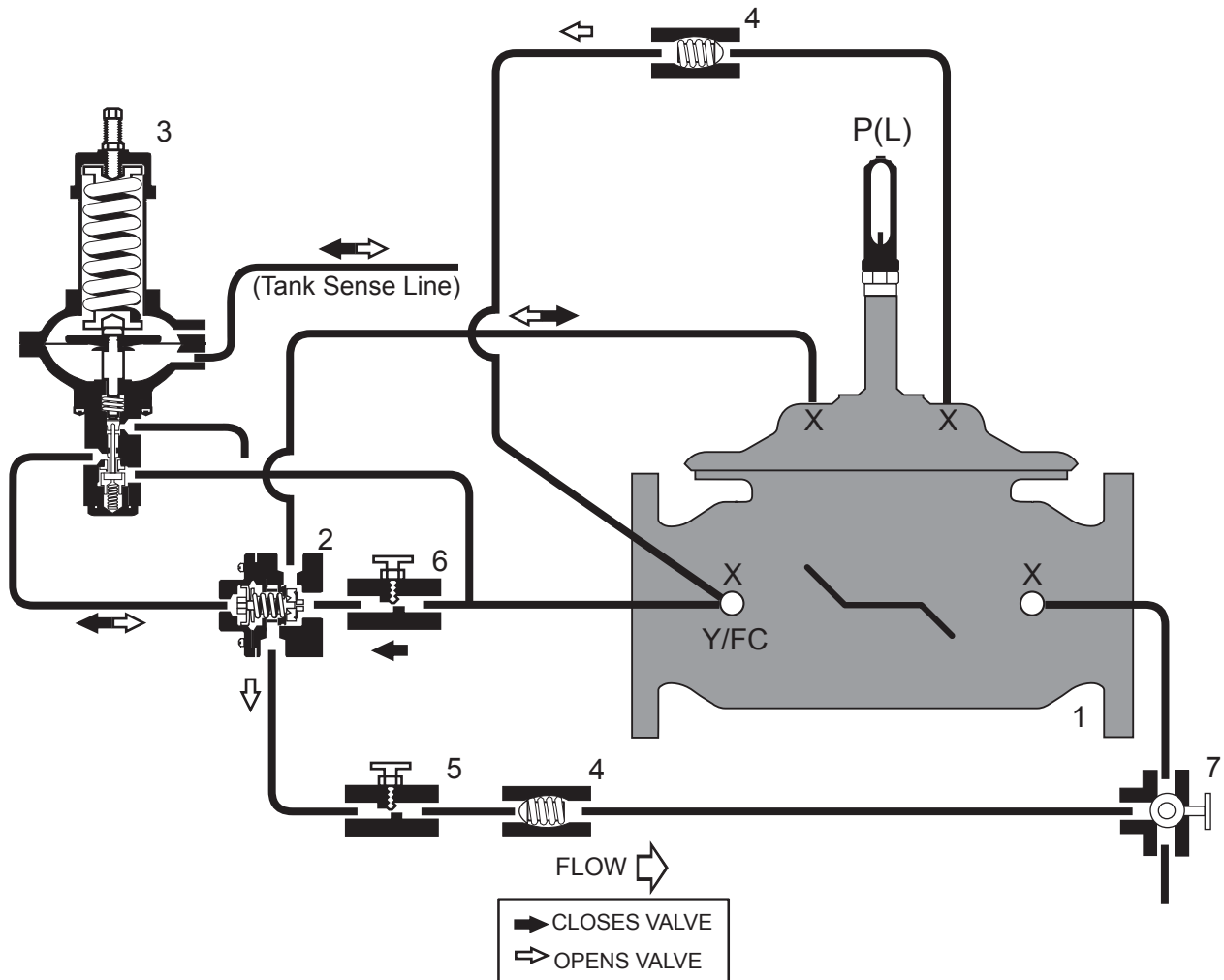

STANDARD COMPONENTS

- 1 - Main Valve (Single Chamber)
- 2 - Model 22-1 Accelerator Control
- 3 - Altitude Control
- 4 - Check Valve
- 5 - Adjustable Opening Speed
- 6 - Adjustable Closing Speed
- 7 - 3-Way Ball Valve
- P - Position Indicator

OPTIONS and ACCESSORIES

- X - Isolation Cocks
- FC - Flo-Clean Strainer
- Y - Y-Strainer (Replaces Flo-Clean)
- L - Limit Switch