

LEAD FREE*

Model LF263AP

Pressure Reducing Pilot

Size: ½" NPT

The Model LF263AP is a direct acting, diaphragm actuated control pilot that automatically reduces a higher upstream (inlet) pressure to a constant downstream (outlet) pressure. It is normally held open by the force of the adjustable spring setting above the diaphragm.

The pilot modulates towards a closed position when outlet pressure exceeds the spring setpoint, lowering the delivery pressure. It modulates towards an open position when the outlet pressure falls below the spring setpoint, increasing the delivery pressure.

When a Model LF263AP is installed in the piping circuit of an Automatic Control Valve, its throttling action causes the Main Valve to throttle open or closed accordingly. Turning the adjustment screw clockwise raises the control setpoint, increasing valve outlet pressure. Turning the adjustment screw counterclockwise lowers the control setpoint, decreasing valve outlet pressure.

The Model LF263AP is equipped with ½" NPT inlet and outlet ports and a ¼" NPT side outlet port. The ¼" NPT side outlet port may be plugged or used as an outlet pressure gauge connection.



Model LF263AP

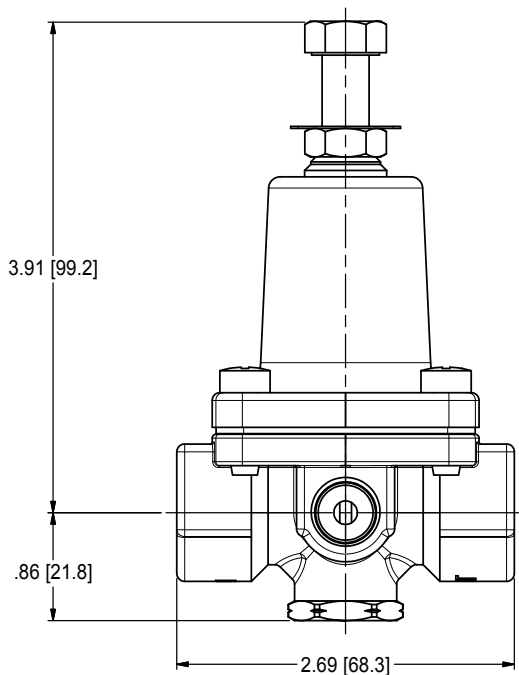

Specifications

Size:	½" NPT
Body Material:	Lead Free Brass
Seat:	Stainless Steel
Elastomers:	Buna-N
Inlet Pressure Rating:	400psi maximum
Adjustment Range:	20-175 (standard) 0-30 (optional)

***The wetted surface of this product contacted by consumable water contains less than 0.25% of lead by weight.**

NOTICE

The information contained herein is not intended to replace the full product installation and safety information available or the experience of a trained product installer. You are required to thoroughly read all installation instructions and product safety information before beginning the installation of this product.

Ames Fire & Waterworks product specifications in U.S. customary units and metric are approximate and are provided for reference only. For precise measurements, please contact Ames Fire & Waterworks Technical Service. Ames Fire & Waterworks reserves the right to change or modify product design, construction, specifications, or materials without prior notice and without incurring any obligation to make such changes and modifications on Ames Fire & Waterworks products previously or subsequently sold.



LEAD FREE*

Model LF263AP

Pressure Reducing Pilot

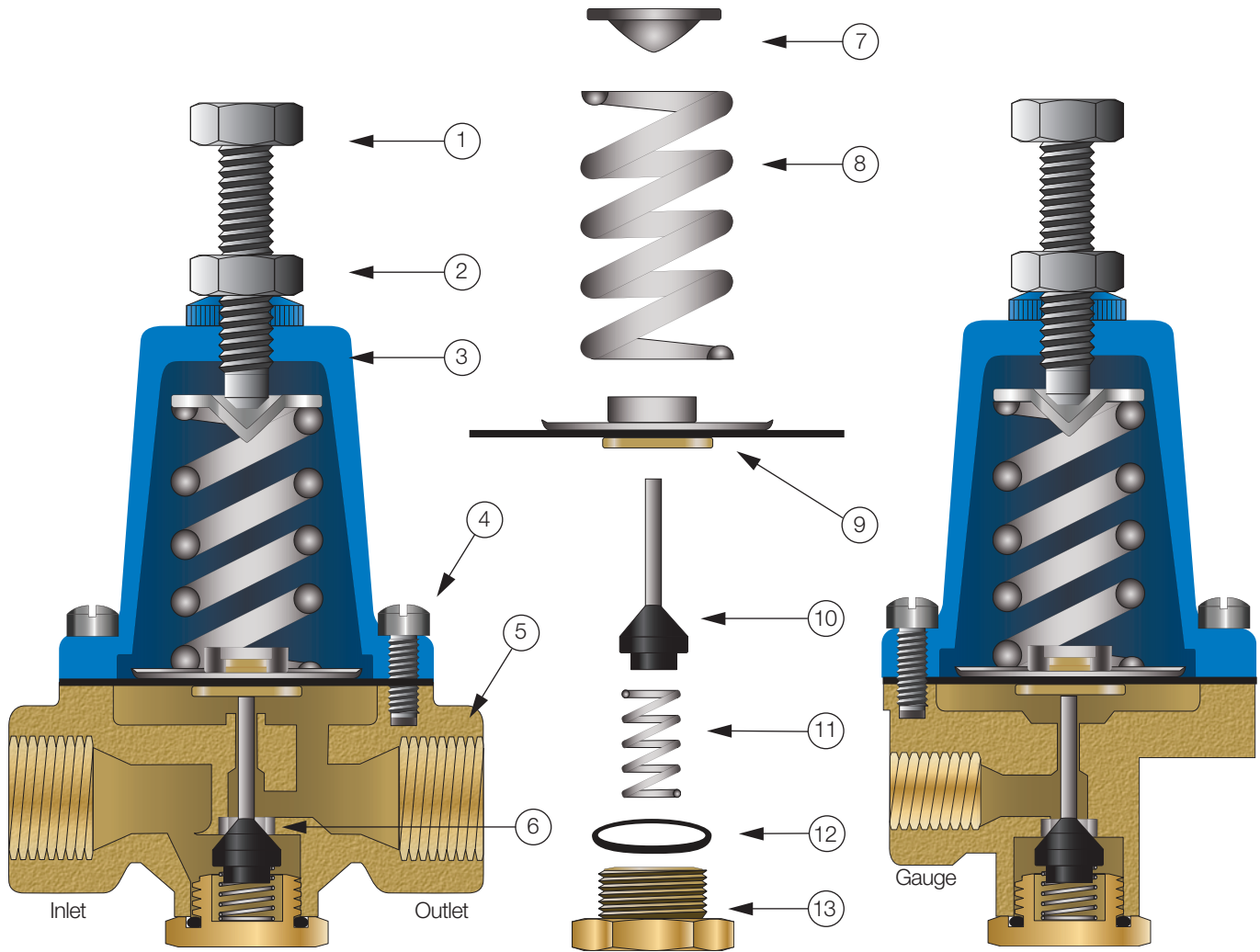

Item	Description
1	Adjusting Screw
2	Jam Nut
3	Spring Housing
4	Cap Screw
5	Body
6	Spring Guide
7	Spring
8	Diaphragm Washer
9	Diaphragm*
10	Stem Guide
11	O-Ring*
12	Stem Assembly*
13	Spring
14	O-Ring*
15	Bottom Cap

*Included in Repair Kit



A Watts Water Technologies Company

USA: Backflow Tel: (978) 689-6066 • Fax: (978) 975-8350 • AmesFireWater.com

USA: Control Valves Tel: (713) 943-0688 • Fax: (713) 944-9445 • AmesFireWater.com

Canada: Tel: (905) 332-4090 • Fax: (905) 332-7068 • AmesFireWater.com

Latin America: Tel: (52) 81-1001-8600 • Fax: (52) 81-8000-7091 • AmesFireWater.com