

M Series Basic Valves

LEAD FREE*

Full Port Ductile Iron Dual Chamber Basic Valve with Mechanical Check Feature

This Ames ACV is a full port, dual chamber basic valve that incorporates a two-piece telescoping disc and diaphragm assembly. This assembly is the only moving part within the valve, allowing it to open or close as commanded by the pilot control system. The lower portion of this two-piece assembly is a mechanical check feature, which acts independent of diaphragm position or pilot control system, and provides immediate check action when flow ceases.

When pressure is applied to the upper diaphragm chamber and released from the lower diaphragm chamber, the valve travels to a closed position. When pressure is applied to the lower diaphragm chamber and released from the upper diaphragm chamber the valve travels to a full open position.

Ames ACV Main Valves are Lead Free. The Ames ACV piloting system contains Lead Free* components, ensuring all of our configurations are Lead Free compliant.

Globe Pattern Dual Chamber Basic Valve with Mechanical Check Feature (900GD-16)

Angle Pattern Dual Chamber Basic Valve with Mechanical Check Feature (900AD-16)

Standard Materials

Body & Cover: Ductile Iron ASTM A536

Coating: NSF Listed Fusion Bonded Epoxy Lined and Coated

Trim: 316 Stainless Steel

Elastomers: Buna-N (standard)
EPDM (optional)
Viton (optional)

Nut, Spring & Stem: Stainless Steel

Anti-Scale (Optional): Xylan Coated Stem and Seat



Operating Pressure

Threaded = 400psi (27.6 bar)

150# Flanged = 250psi (17.2 bar)

300# Flanged = 400psi (27.6 bar)

Grooved End = 400psi (27.6 bar)

***The wetted surface of this product contacted by consumable water contains less than 0.25% of lead by weight.**

Viton® is a registered trademark of DuPont Dow Elastomers.

NOTICE

The information contained herein is not intended to replace the full product installation and safety information available or the experience of a trained product installer. You are required to thoroughly read all installation instructions and product safety information before beginning the installation of this product.

Ames Fire & Waterworks product specifications in U.S. customary units and metric are approximate and are provided for reference only. For precise measurements, please contact Ames Fire & Waterworks Technical Service. Ames Fire & Waterworks reserves the right to change or modify product design, construction, specifications, or materials without prior notice and without incurring any obligation to make such changes and modifications on Ames Fire & Waterworks products previously or subsequently sold.



Globe Flanged



Angle Flanged



Globe Grooved End



Angle Grooved End



Globe Threaded



Angle Threaded

Operating Temperature

Buna-N: 160°F (71°C) Maximum

EPDM: 300°F (140°C) Maximum

Viton®: 250°F (121°C) Maximum

Epoxy Coating**: 225°F (107°C) Maximum

** Valves can be provided without internal epoxy coating consult factory



Full Port Ductile Iron Dual Chamber Basic Valve with Mechanical Check Feature

Flow Data

Valve Size - Inches		2	2½	3	4	6	8	10	12	14	16
Suggested	Maximum Continuous Flow Rate Gpm (Water)	210	300	485	800	1850	3100	5000	7000	8500	11100
	Maximum Intermittent Flow Rate Gpm (Water)	265	390	590	1000	2300	4000	6250	8900	10800	14100
C _v	Minimum Flow Rate Gpm (Water)	6	9	15	16	17	25	55	70	190	400
	Factor GPM (Globe)	48	75	112	188	387	764	1215	1734	2234	3131
	Factor GPM (Angle)	57	91	125	207	571	889	1530	1945		

- Maximum continuous flow based on velocity of 20 ft. per second.
- Maximum intermittent flow based on velocity of 25 ft. per second.
- Minimum flow rates based on a 20-40 psi pressure drop.
- The C_v Factor of a valve is the flow rate in US GPM at 60°F that will cause a 1psi drop in pressure.
- C_v factor can be used in the following equations to determine Flow (Q) and Pressure Drop (ΔP):

$$Q \text{ (Flow)} = C_v \sqrt{\Delta P} \quad \Delta P \text{ (Pressure Drop)} = (Q/C_v)^2$$

- The C_v factors stated are based upon a fully open valve.
- Many factors should be considered in sizing control valves including inlet pressure, outlet pressure and flow rates.
- For sizing questions including cavitation analysis consult Watts with system details.

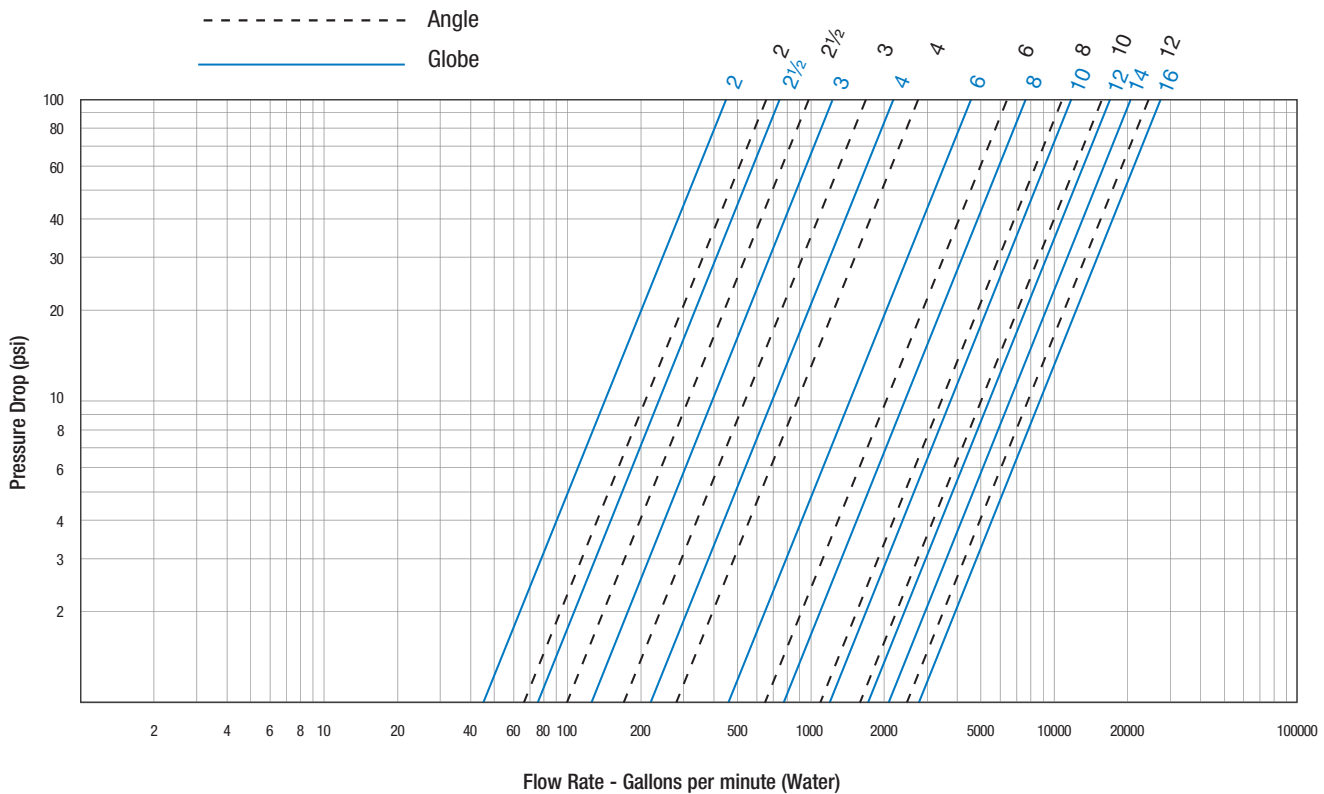

Valve Cover Chamber Capacity

Valve Size (in)	2	2½	3	4	6	8	10	12	14	16
fl.oz.	4	10	16	22	70					
U.S. Gal						1 ¼	2 ½	4	6 ½	9 ½

Valve Travel

Valve Size (in)	2	2½	3	4	6	8	10	12	14	16
Travel (in)	½	¾	¾	1	1½	2	2½	3	3½	4

Full Port Ductile Iron Dual Chamber Basic Valve with Mechanical Check Feature

LEAD FREE*

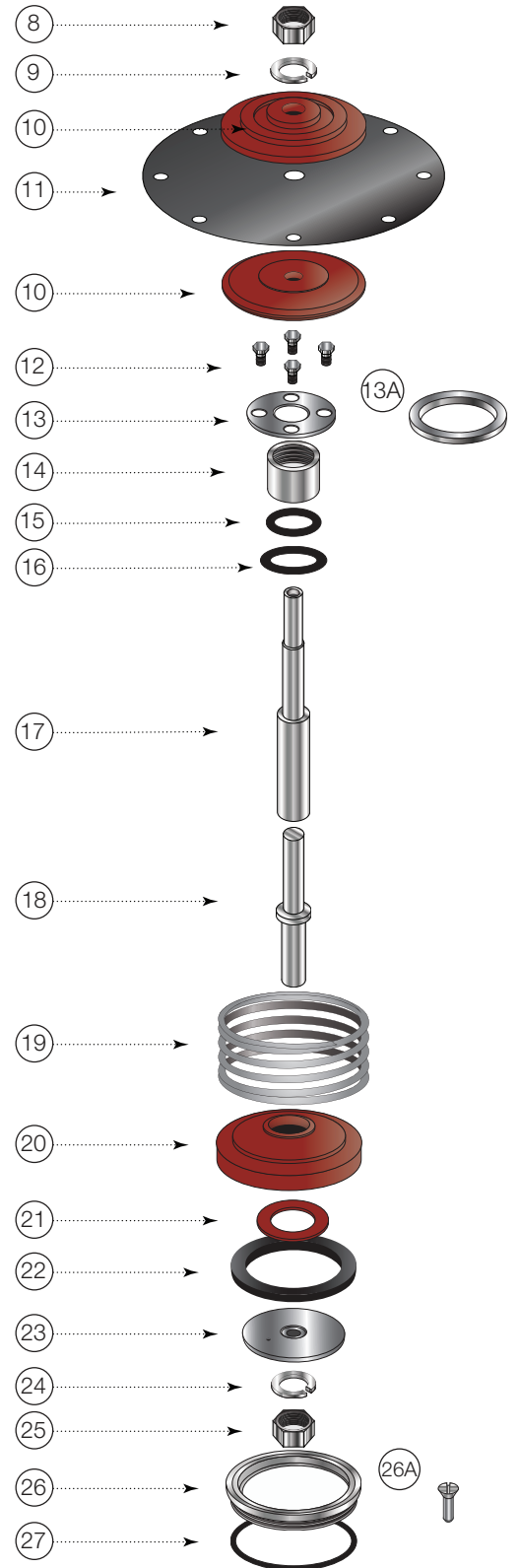
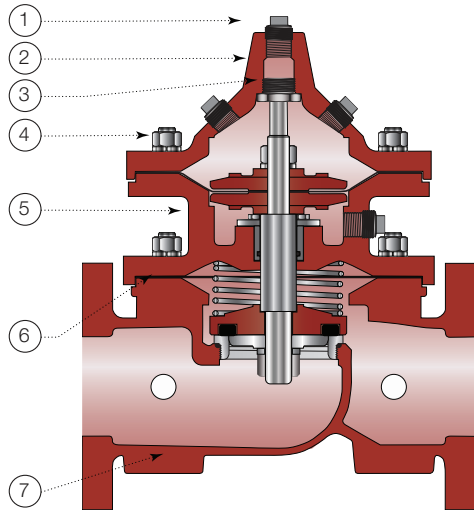

ITEM	DESCRIPTION	MATERIAL
1	Pipe Plug	Lead Free Brass
2	Cover	ASTM A536 65-45-12 Epoxy Coated Ductile Iron
3	Cover Bearing	ASTM A276 304 Stainless Steel
4	Stud with Cover Nut & Washer	ASTM A570 Gr.33 Zinc Plated Steel
5	Upper Body	ASTM A536 65-45-12 Epoxy Coated Ductile Iron
6	Gasket Seal	Buna-N (Nitrile)
7	Body	ASTM A536 65-45-12 Epoxy Coated Ductile Iron
8	Stem Nut	ASTM A276 304 Stainless Steel
9	Lock Washer	ASTM A276 302 Stainless Steel
10	Diaphragm Washer	ASTM A536 65-45-12 Epoxy Coated Ductile Iron
11	Diaphragm*	Buna-N (Nitrile)
12	Inner Bearing Bolts** (3" and Smaller)	ASTM A276 304 Stainless Steel
13	Inner Bearing Retainer** (3" and Smaller)	ASTM A276 302 Stainless Steel
13A	Bearing Retaining Ring** (4" and Larger)	ASTM A276 302 Stainless Steel
14	Inner Bearing	ASTM A276 304 Stainless Steel
15	O-ring*	Buna-N (Nitrile)
16	O-ring*	Buna-N (Nitrile)
17	Upper Stem	ASTM A276 304 Stainless Steel
18	Lower Stem	ASTM A276 304 Stainless Steel
19	Spring	ASTM A276 302 Stainless Steel
20	Disc Retainer	ASTM A536 65-45-12 Epoxy Coated Ductile Iron
21	Spacer Washer*	NY300 Fiber
22	Disc*	Buna-N (Nitrile)
23	Disc Guide	ASTM A743 CF8M (316) Stainless Steel
24	Lock Washer	ASTM A276 304 Stainless Steel
25	Stem Nut	ASTM A276 304 Stainless Steel
26	Seat Ring***	ASTM A743 CF8M (316) Stainless Steel
26A	Seat Screw*** (8" and Larger)	ASTM A276 304 Stainless Steel
27	Seat Gasket *	Buna-N (Nitrile)

* Contained in Main Valve Repair Kit

**4 inch and larger valves do not require Bearing Bolts

***6 inch and smaller valves, Seat Ring is threaded

NOTICE

Installation: If unit is installed in any orientation other than horizontal (cover up) OR extreme space constraints exist, consult customer service prior to or at the time of order.

Full Port Ductile Iron Dual Chamber Basic Valve with Mechanical Check Feature

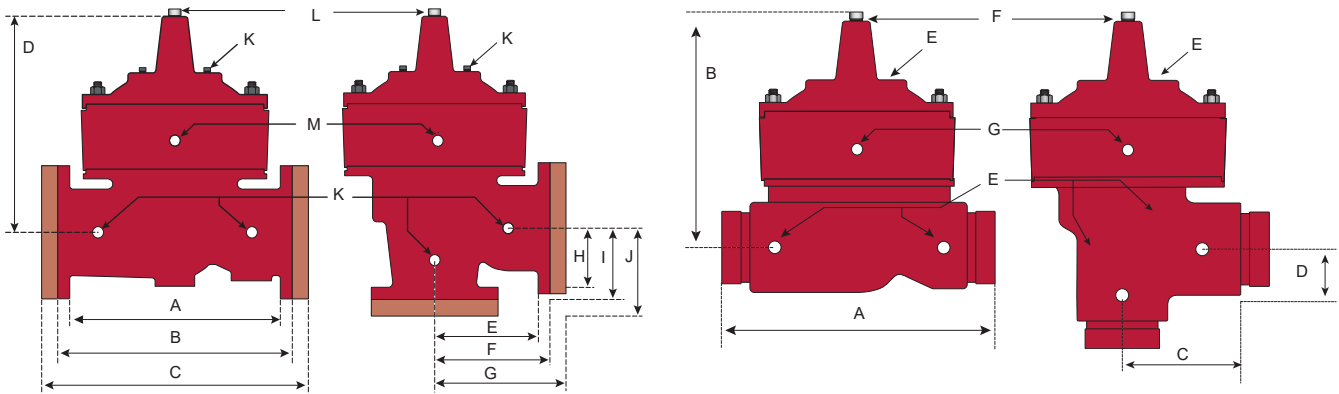

Flanged and Threaded Dimensions

Valve Size	Globe Thread		Globe 150#		Globe 300#		Cover to Center		Angle Thread		Angle 150#		Angle 300#		Angle Thread		Angle 150#		Angle 300#		Port Size NPT	Port Size NPT	Port Size NPT	Shipping Weights*	
	in.	mm	in.	mm	in.	mm	in.	mm	in.	mm	in.	mm	in.	mm	in.	mm	in.	mm	in.	mm	in.	in.	in.	lbs.	kgs.
2	9 ³ / ₈	238	9 ³ / ₈	238	10	254	9	230	4	120	4 ³ / ₄	121	5	127	3 ¹ / ₄	83	3 ³ / ₄	83	3 ¹ / ₂	89	3/8	1/2	1/4	45	20
2 ¹ / ₂	11	279	11	279	11 ⁵ / ₈	295	10 ⁹ / ₁₆	262	5 ¹ / ₂	140	5 ¹ / ₂	140	5 ⁷ / ₈	149	4	102	4	102	4 ⁹ / ₁₆	110	1/2	1/2	1/2	70	32
3	12 ¹ / ₂	318	12	305	13 ¹ / ₄	337	11 ¹ / ₂	291	6 ¹ / ₄	159	6	152	6 ³ / ₈	162	4 ¹ / ₂	114	4	102	4 ³ / ₈	111	1/2	1/2	1/2	100	45
4			15	381	15 ⁵ / ₈	397	14 ³ / ₈	365			7 ¹ / ₂	191	7 ⁷ / ₈	200			5	127	5 ⁵ / ₁₆	135	3/4	3/4	1/2	200	91
6			20	508	21	533	18 ⁷ / ₁₆	468			10	254	10 ¹ / ₂	267			6	152	6 ¹ / ₂	165	3/4	3/4	3/4	340	154
8			25 ³ / ₈	645	26 ³ / ₈	670	21 ³ / ₄	554			12 ³ / ₄	324	13 ¹ / ₄	337			8	203	8 ¹ / ₂	216	1	1	1	665	302
10			29 ³ / ₄	756	31 ¹ / ₈	791	23 ³ / ₈	594			14 ⁷ / ₈	378	15 ¹⁵ / ₁₆	395			8 ⁵ / ₈	219	9 ⁹ / ₁₆	237	1	1	1	980	445
12			34	864	35 ¹ / ₂	902	29 ⁹ / ₁₆	745			17	432	17 ³ / ₄	451			13 ³ / ₄	349	14 ¹ / ₂	368	1	1 ¹ / ₄	1	1720	780
14			39	991	40 ¹ / ₂	1029	33	838													1	1 ¹ / ₂	1	2600	1180
16			41 ³ / ₈	1051	43 ¹ / ₂	1105	35	889													1	2	1	3300	1497

Grooved End Dimensions

Valve Size	Globe Grooved		Cover To Center		Angle Grooved		Angle Grooved		Port Size (npt)	Port Size (npt)	Port Size (npt)	Shipping Weights*	
	in.	mm	in.	mm	in.	mm	in.	mm	in.	in.	in.	lbs.	kgs.
2	9	229	6 ¹ / ₂	165	4 ³ / ₄	121	3 ³ / ₄	83	3/8	1/2	1/2	50	23
2 ¹ / ₂	11	279	7 ¹ / ₂	191	5 ¹ / ₂	140	4	102	1/2	1/2	1/2	85	39
3	12 ¹ / ₂	318	8 ¹ / ₄	210	6	152	4 ¹ / ₄	108	1/2	1/2	1/2	125	57
4	15	381	10 ⁵ / ₈	270	7 ¹ / ₂	191	5	127	3/4	3/4	3/4	250	114
6	20	508	13 ³ / ₈	340					3/4	3/4	1	420	191
8	25 ³ / ₈	645	16	406					1	1	1	845	384



A WATTS Brand

USA: Backflow T: (978) 689-6066 • F: (978) 794-1848 • AmesFireWater.com
 USA: Control Valves T: (713) 943-0688 • F: (713) 944-9445 • AmesFireWater.com
 Canada: T: (905) 332-4090 • F: (905) 332-7068 • AmesFireWater.ca
 Latin America: T: (52) 81-1001-8600 • AmesFireWater.com