

M Series Basic Valves

LEAD FREE*

Reduced Port Ductile Iron Single Chamber Basic Valve

This Ames ACV is a reduced port, single chamber basic valve that incorporates a one-piece disc and diaphragm assembly. This assembly is the only moving part within the valve, allowing it to open, close, or modulate as commanded by the pilot control system. The reduced port design offers improved low-flow performance.

Ames ACV Main Valves are Lead Free. The Ames ACV piloting system contains Lead Free* components, ensuring all of our configurations are Lead Free compliant.

Globe Pattern Single Chamber Basic Valve (605GD)

Angle Pattern Single Chamber Basic Valve (605AD)

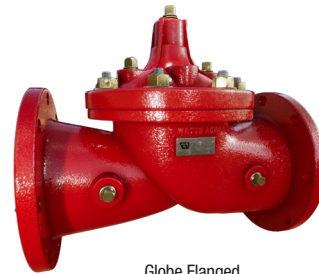

Globe Flanged



Angle Flanged

Standard Materials

Body & Cover: Ductile Iron ASTM A536

Coating: NSF Listed Fusion Bonded Epoxy Lined and Coated

Trim: 316 Stainless Steel

Elastomers: Buna-N (standard)
EPDM (optional)
Viton (optional)

Nut, Spring & Stem: Stainless Steel

Anti-Scale (Optional): Xylan Coated Stem and Seat



Certified to
NSF/ANSI 61-G

Operating Pressure

150# Flanged = 250psi (17.2 bar)

300# Flanged = 400psi (27.6 bar)

Operating Temperature

Buna-N: 160°F (71°C) Maximum

EPDM: 300°F (140°C) Maximum

Viton®: 250°F (121°C) Maximum

Epoxy Coating**: 225°F (107°C) Maximum

** Valves can be provided without internal epoxy coating consult factory

*The wetted surface of this product contacted by consumable water contains less than 0.25% of lead by weight.

Viton® is a registered trademark of DuPont Dow Elastomers.

NOTICE

The information contained herein is not intended to replace the full product installation and safety information available or the experience of a trained product installer. You are required to thoroughly read all installation instructions and product safety information before beginning the installation of this product.

Ames Fire & Waterworks product specifications in U.S. customary units and metric are approximate and are provided for reference only. For precise measurements, please contact Ames Fire & Waterworks Technical Service. Ames Fire & Waterworks reserves the right to change or modify product design, construction, specifications, or materials without prior notice and without incurring any obligation to make such changes and modifications on Ames Fire & Waterworks products previously or subsequently sold.



Reduced Port Ductile Iron Single Chamber Basic Valve

Flow Data

| Valve Size - Inches | | 3 | 4 | 6 | 8 | 10 | 12 | 16 | 18 | 20 | 24 |
|----------------------|--|-----|-----|------|------|------|------|------|-------|-------|-------|
| Suggested | Maximum Continuous Flow Rate Gpm (Water) | 210 | 485 | 800 | 1850 | 3100 | 5000 | 7000 | 11100 | 11100 | 11100 |
| | Maximum Intermittent Flow Rate Gpm (Water) | 265 | 590 | 1000 | 2300 | 4000 | 6250 | 8900 | 14100 | 14100 | 14100 |
| | Minimum Flow Rate Gpm (Water) | 6 | 15 | 16 | 17 | 25 | 55 | 70 | 400 | 400 | 400 |
| C_v | Factor GPM (Globe) | 60 | 120 | 224 | 402 | 932 | 1314 | 2067 | 2881 | 2881 | 2881 |
| | Factor GPM (Angle) | | 132 | 237 | 534 | | | | | | |

- Maximum continuous flow based on velocity of 20 ft. per second.
- Maximum intermittent flow based on velocity of 25 ft. per second.
- Minimum flow rates based on a 20-40 psi pressure drop.
- The C_v Factor of a valve is the flow rate in US GPM at 60°F that will cause a 1psi drop in pressure.
- C_v factor can be used in the following equations to determine Flow (Q) and Pressure Drop (ΔP):

$$Q \text{ (Flow)} = C_v \sqrt{\Delta P} \quad \Delta P \text{ (Pressure Drop)} = (Q/C_v)^2$$
- The C_v factors stated are based upon a fully open valve.
- Many factors should be considered in sizing control valves including inlet pressure, outlet pressure and flow rates.
- For sizing questions including cavitation analysis consult Watts with system details.

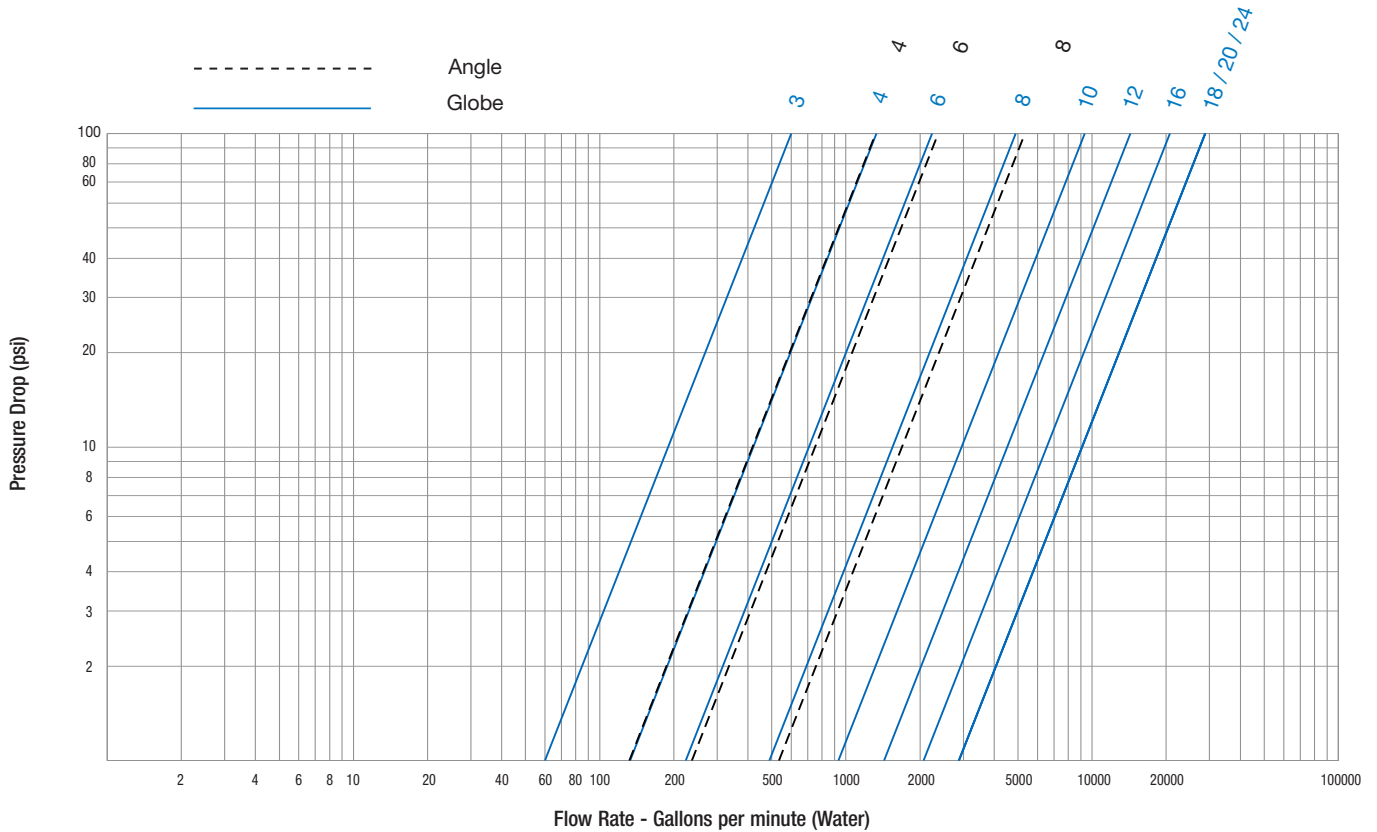

Valve Cover Chamber Capacity

| Valve Size (in) | 3 | 4 | 6 | 8 | 10 | 12 | 16 | 18 | 20 | 24 |
|-----------------|---|----|----|----|----|----|----|----|----|----|
| fl.oz. | 4 | 10 | 22 | 70 | | | | | | |
| U.S. Gal | | | | | 1¼ | 2½ | 4 | 9½ | 9½ | 9½ |

Valve Travel

| Valve Size (in) | 3 | 4 | 6 | 8 | 10 | 12 | 16 | 18 | 20 | 24 |
|-----------------|---|---|---|----|----|----|----|----|----|----|
| (in) | ½ | ¾ | 1 | 1½ | 2 | 2½ | 3 | 4 | 4 | 4 |

Reduced Port Ductile Iron Single Chamber Basic Valve

LEAD FREE*

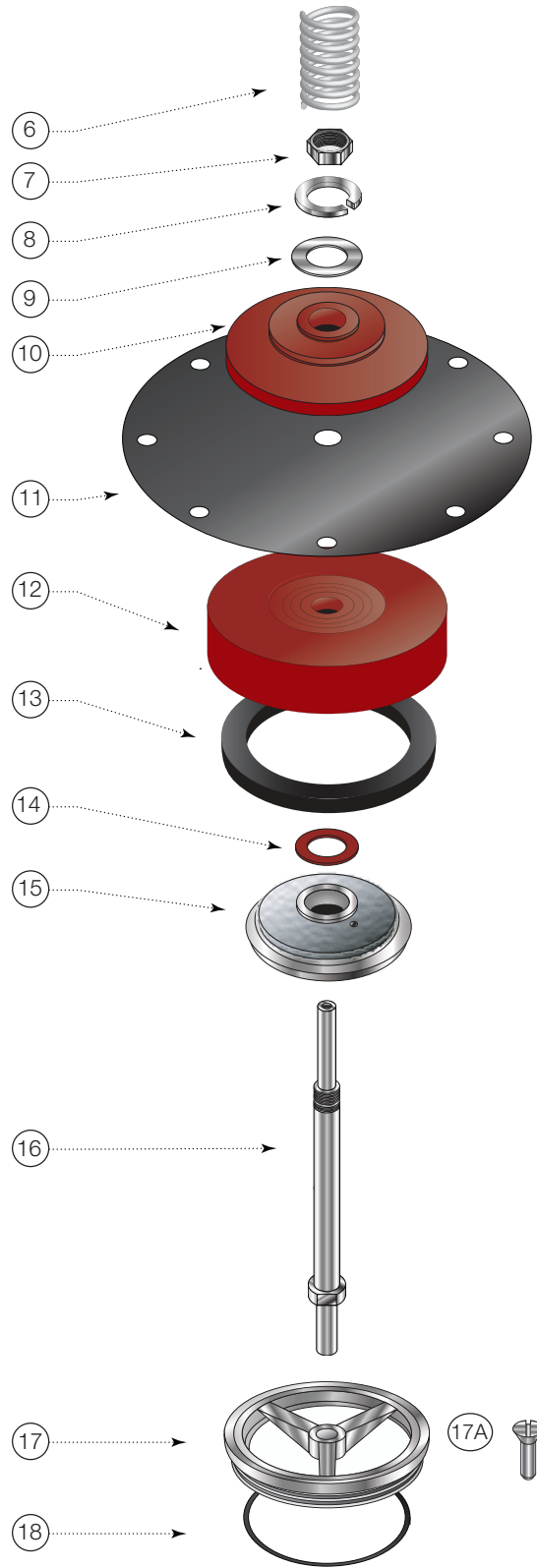
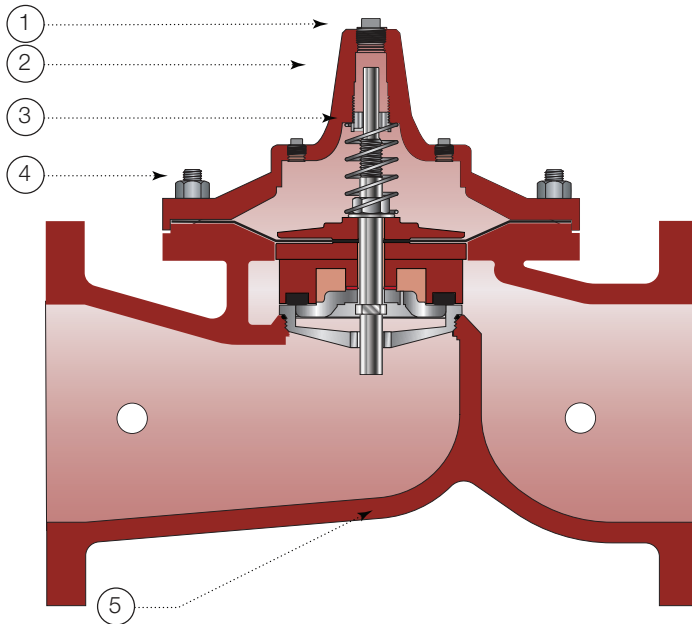

| ITEM | DESCRIPTION | MATERIAL |
|------|--------------------------------|--|
| 1 | Pipe Plug | Lead Free Brass |
| 2 | Cover | ASTM A536 65-45-12 Epoxy Coated Ductile Iron |
| 3 | Cover Bearing | ASTM A276 304 Stainless Steel |
| 4 | Stud with Cover Nut and Washer | ASTM A570 Gr.33 Zinc Plated Steel |
| 5 | Body | ASTM A536 65-45-12 Epoxy Coated Ductile Iron |
| 6 | Spring | ASTM A276 302 Stainless Steel |
| 7 | Stem Nut | ASTM A276 304 Stainless Steel |
| 8 | Lock Washer | ASTM A276 304 Stainless Steel |
| 9 | Stem Washer | ASTM A276 304 Stainless Steel |
| 10 | Diaphragm Washer | ASTM A536 65-45-12 Epoxy Coated Ductile Iron |
| 11 | Diaphragm* | Buna-N (Nitrile) |
| 12 | Disc Retainer | ASTM A536 65-45-12 Epoxy Coated Ductile Iron |
| 13 | Seat Disc* | Buna-N (Nitrile) |
| 14 | Spacer Washer* x5 | NY300 Fiber* |
| 15 | Disc Guide | ASTM A743 CF8M (316) Stainless Steel |
| 16 | Shaft | ASTM A276 304 Stainless Steel |
| 17 | Seat Ring** | ASTM A743 CF8M (316) Stainless Steel |
| 17A | Seat Screw** (10" and Larger) | ASTM A276 304 Stainless Steel |
| 18 | Seat Gasket* | Buna-N (Nitrile) |

* Contained in Main Valve Repair Kit

**Note: 8 inch and Smaller Valves, Seat Ring is threaded

NOTICE

Installation: If unit is installed in any orientation other than horizontal (cover up) OR extreme space constraints exist, consult customer service prior to or at the time of order.

Reduced Port Ductile Iron Single Chamber Basic Valve

Dimensions

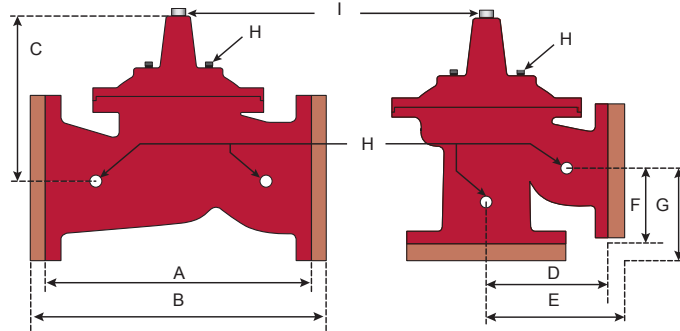

| Valve Size | Globe 150# | | Globe 300# | | Cover To Center | | Angle 150# | | Angle 300# | | Angle 150# | | Angle 300# | | Port Size NPT | Port Size NPT | Shipping Weights* | |
|------------|------------|------|------------|-----|-----------------|-----|------------|-----|------------|-----|------------|-----|------------|-----|---------------|---------------|-------------------|-----|
| | A | | B | | C | | D | | E | | F | | G | | H | I | lbs. | kg. |
| in. | in. | mm | in. | mm | in. | mm | in. | mm | in. | mm | in. | mm | in. | mm | in. | in. | | |
| 3 | 10¼ | 260 | 11 | 279 | 6⅝ | 169 | | | | | | | | | ¾ | ½ | 21 | 10 |
| 4 | 13⅞ | 352 | 14½ | 368 | 8½ | 214 | 6⅞ | 176 | 7¼ | 184 | 5½ | 140 | 5⅞ | 148 | ½ | ½ | 39 | 18 |
| 6 | 17¾ | 451 | 18⅞ | 473 | 11½ | 288 | 8⅞ | 225 | 9⅞ | 238 | 6¾ | 171 | 7¼ | 184 | ¾ | ¾ | 89 | 40 |
| 8 | 21⅞ | 543 | 22⅞ | 568 | 14½ | 369 | 10⅞ | 271 | 11⅞ | 284 | 7¼ | 184 | 7¾ | 197 | ¾ | ¾ | 150 | 68 |
| 10 | 26 | 660 | 27⅞ | 695 | 17⅞ | 448 | | | | | | | | | 1 | 1 | 283 | 128 |
| 12 | 30 | 762 | 31½ | 800 | 20⅞ | 523 | | | | | | | | | 1 | 1 | 408 | 185 |
| 16 | 35 | 889 | | | 25¾ | 654 | | | | | | | | | 1 | 1¼ | 626 | 234 |
| 18 | 48 | 1219 | | | 31 | 787 | | | | | | | | | 1 | 2 | 1145 | 519 |
| 20 | 48 | 1219 | | | 31 | 787 | | | | | | | | | 1 | 2 | 1170 | 531 |
| 24 | 48 | 1219 | | | 31 | 787 | | | | | | | | | 1 | 2 | 1265 | 574 |



A WATTS Brand

USA: Backflow T: (978) 689-6066 • F: (978) 794-1848 • AmesFireWater.com
 USA: Control Valves T: (713) 943-0688 • F: (713) 944-9445 • AmesFireWater.com
 Canada: T: (905) 332-4090 • F: (905) 332-7068 • AmesFireWater.ca
 Latin America: T: (52) 81-1001-8600 • AmesFireWater.com