

Basic Installation Instructions

- A. Ames dual check valves may be installed in either a vertical or a horizontal position. Series 20 should be installed downstream of the water meter and of the water pressure regulator. All outlets including sill cocks must be downstream of the Series 20. Series 20S should be installed at the fire sprinkler service connection to the main line.
- B. They should always be installed in an accessible location to facilitate the removal for servicing and testing.
- C. Pipe lines should be thoroughly flushed to remove foreign material before installing the unit.
- D. Protect from freezing
- E. Ensure that valve is installed in proper flow direction. Refer to flow direction arrow on valve nameplate or body.
- F. When installing valve in pipe line, only use wrenching flats provided. Do not apply wrench to body of valve. This will prevent distorting the valve body and component parts.
- G. These valves incorporate an O-ring union seal that requires minimum tightening of union nut. Do not overtighten.
- H. These valves contain plastic check modules and should never be directly sweated into the line. Sweat fit adapters should be sweated into the line prior to valve installation.
- I. Avoid improper application and excessive pipe sealants such as Teflon[®] tape and pipe dope.

IMPORTANT: Inquire with governing authorities for local installation requirements.

NOTE: When a pressure reducing valve or dual check valve is installed in the supply line it creates a closed system which makes plumbing code compliance imperative for system safety. Special attention must be given by all concerned to assure pressure relief protection is provided to protect water heater equipment. It is important to make certain an approved ANSI Z21.22 temperature and pressure relief valve is installed on the storage water heater.

High System Pressure

If the downstream system pressure is higher than the set pressure under no flow conditions, the cause could be thermal expansion, pressure creep or dirt/debris on the seat.

Thermal expansion occurs whenever water is heated in a closed system. The system is closed when supply pressure exceeds 150psi (10.3 bar), or a check valve or backflow preventer is installed in the supply piping.

You must make provisions for pressure relief protection of your plumbing system and components. The use of a relief valve or potable water expansion tank may be required.

To determine if this is the result of thermal expansion, try briefly opening the cold water tap. If the increased pressure is caused by thermal expansion, the pressure will immediately be relieved and the system will return to the set pressure.

Limited Warranty: Ames Company warrants each product to be free from defects in material and workmanship under normal usage for a period of one year from the date of original shipment. In the event of such defects within the warranty period, the Company will, at its option, replace or recondition the product without charge.

THE WARRANTY SET FORTH HEREIN IS GIVEN EXPRESSLY AND IS THE ONLY WARRANTY GIVEN BY THE COMPANY WITH RESPECT TO THE PRODUCT. THE COMPANY MAKES NO OTHER WARRANTIES, EXPRESS OR IMPLIED. THE COMPANY HEREBY SPECIFICALLY DISCLAIMS ALL OTHER WARRANTIES, EXPRESS OR IMPLIED, INCLUDING BUT NOT LIMITED TO THE IMPLIED WARRANTIES OF MERCHANTABILITY AND FITNESS FOR A PARTICULAR PURPOSE.

The remedy described in the first paragraph of this warranty shall constitute the sole and exclusive remedy for breach of warranty, and the Company shall not be responsible for any incidental, special or consequential damages, including without limitation, lost profits or the cost of repairing or replacing other property which is damaged if this product does not work properly, other costs resulting from labor charges, delays, vandalism, negligence, fouling caused by foreign material, damage from adverse water conditions, chemical, or any other circumstances over which the Company has no control. This warranty shall be invalidated by any abuse, misuse, misapplication, improper installation or improper maintenance or alteration of the product.

Some States do not allow limitations on how long an implied warranty lasts, and some States do not allow the exclusion or limitation of incidental or consequential damages. Therefore the above limitations may not apply to you. This Limited Warranty gives you specific legal rights, and you may have other rights that vary from State to State. You should consult applicable state laws to determine your rights. **SO FAR AS IS CONSISTENT WITH APPLICABLE STATE LAW, ANY IMPLIED WARRANTIES THAT MAY NOT BE DISCLAIMED, INCLUDING THE IMPLIED WARRANTIES OF MERCHANTABILITY AND FITNESS FOR A PARTICULAR PURPOSE, ARE LIMITED IN DURATION TO ONE YEAR FROM THE DATE OF ORIGINAL SHIPMENT.**

Service, Replacement Parts and Maintenance

Servicing Series 20, 20S

1. Remove the Series 20 from the line (union nut and adapter remain in the line).
2. Remove the two check modules by pressing firmly from the outlet end (end with wrench pads). O-ring seals will be removed with the removal of modules from the body.

CAUTION: To prevent damage to O-ring seals, do not attempt to pry the O-ring seal free before removing check modules.

NOTE: Complete check module assemblies are available as replacement parts. It is recommended that if check modules are fouled, that the entire check module be replaced.

3. Inspect body bore and clean surfaces of any foreign material.
4. Using silicone grease, apply small amount to each exterior surface of the O-ring seals. If O-ring is to be replaced, lubricate as above. A light application of silicone grease to inlet of body bore is beneficial. Do not lubricate seat of seat disc.

NOTE: Only FDA approved silicone grease should be used and is furnished with each Ames Model 20, 20S dual check repair kit.

5. Reinsert the check modules and O-rings into body in direction of flow.

NOTE 1: For 20S the spacer slots must be aligned with the ribs of the first check module before inserting

NOTE 2: 1st and 2nd check modules are identical and interchangeable. Do not overtighten union nut.

Series 20

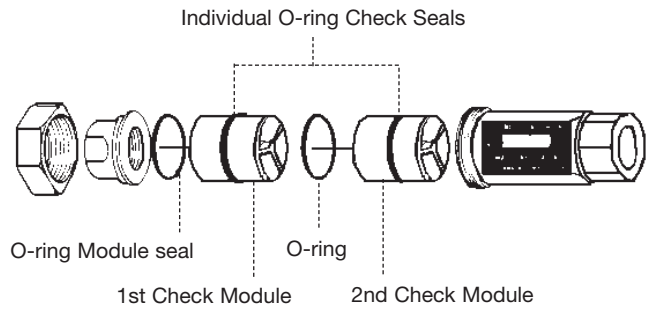

Kit for Series 20, 20S

ORDERING CODE	KIT NO.	SIZE	
		in.	mm
0085613	RK 20/Cu20 T	1/2 - 1 1/4 20	15 - 32
		1/2 - 1 Cu20	15 - 25
0085614	RK 20S T	1 - 1 1/4 20S	25 - 32

Kit Includes: First and Second Check modules, O-rings and spacers if needed.

Servicing Model L20

1. Shut off water at street side of meter.
2. Remove covers and remove Disc Assembly.
3. Inspect rubber disc for dirt or debris.
4. Clean and/or replace as needed.
5. Inspect machined seat area for nicks and mineral build up clean with emery cloth.
6. Reassemble the check assembly in the reverse order. (1st and 2nd check modules are identical and interchangeable)

WARNING!

For valves with CPVC or PEX end connections do not exceed the tubing manufacturers pressure and temperature ratings. Refer to the tubing manufacturers product specifications for that information.

Series L20

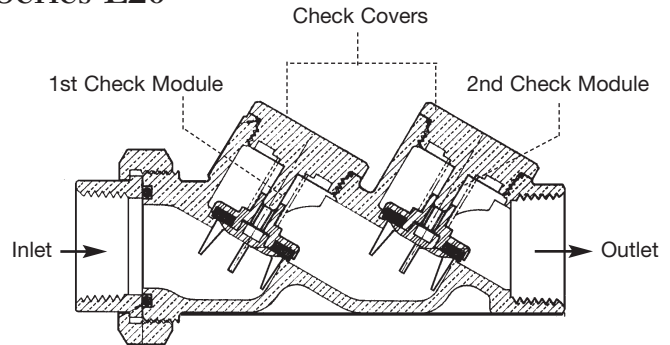

Kit for Series L20

ORDERING CODE	KIT NO.	SIZE	
		in.	mm
0085615	RK L20 T	3/4, 1	20 - 25

CALIFORNIA PROPOSITION 65 WARNING

WARNING: This product contains chemicals known to the State of California to cause cancer and birth defects or other reproductive harm. (California law requires this warning to be given to customers in the State of California.)

For more information: www.watts.com/prop65



A Division of Watts Water Technologies, Inc.

www.amesfirewater.com



USA: Backflow- 1427 N. Market Blvd • Suite #9 • Sacramento, CA 95834 • T: 916-928-0123 • F: 916-928-9333

Control Valves- 18550 Hansen Road • Houston, TX 77075 • T: 713-943-0688 • F: 713-944-9445

Canada: 5435 North Service Rd. • Burlington, ONT. L7L 5H7 • T: 905-332-4090 • F: 905-332-7068