

For Residential Applications

Job Name _____

Contractor _____

Job Location _____

Approval _____

Engineer _____

Contractor's P.O. No. _____

Approval _____

Representative _____

LEAD FREE*

Model OFTWH-R OneFlow® Anti-Scale System

Inlet/Outlet Connections: 3/4" FNPT (19.05 mm)

Nominal Flow Rate up to 6 gpm (22.71 lpm)

The OneFlow® Anti-Scale System provides protection from scale formation on internal plumbing surfaces. The OneFlow® system is a single cartridge-based system that must be installed on a cold water line prior to a single water heating device (water heater or tankless water heater).

OneFlow® uses template assisted crystallization (T.A.C.) to attract hardness minerals and convert them into harmless, inactive microscopic crystal particles.

These crystals stay suspended in the water and are passed to drain. The system requires very little maintenance, no backwashing, no salt and no electricity. Typical hardness problems, especially build-up of scale in heating elements, pipes, water heaters, boilers and on fixtures are no longer a concern.

OneFlow® is not a water softener. It does not add chemicals. It is a scale prevention device with proven third party laboratory test data and years of successful commercial, residential and foodservice applications. OneFlow® is the intelligent scale solution and is a great alternative to water softening (ion exchange) or scale sequestering devices.

Features

- Chemical-free scale prevention and protection - converts hardness minerals to harmless, inactive microscopic crystals making OneFlow® an effective alternative to ion exchange water softeners
- Virtually maintenance free - No salt bags or other chemicals to constantly add or maintain
- No control valve, no electricity and no wastewater
- Uses environmentally friendly "green" technology
- Improves efficiency of all water heating devices and downstream plumbing components
- Simple sizing & installation – standard 3/4" connections
- Perfect system for homes where equipment protection is desired for longer equipment life and reduced energy consumption
- Inlet ball valve for easy isolation shutoff and filter changes
- OneFlow® cartridge-based systems are easily maintained; change the cartridge once every two years
- Easily installed mounting bracket included w/filter wrench to allow cartridge change-outs when necessary

NOTICE

For hot water applications where untreated feed water temperature is 100°F - 140°F (38°C - 60°C), please consult ES-OneFlow-HotWater.



OFTWH-R

Replacement Cartridge

OFTWH-RM-R Cartridge should be replaced every 2 YEARS.

Specifications

A OneFlow® scale prevention system shall be installed on the cold water service line to condition the tap water just prior to the service line feeding the equipment it is designed to protect. The system will be sized for maximum or peak flow rate based on the specification of said equipment. A OneFlow® system may also be installed to protect multiple pieces of equipment from the ill-effects of hard water scale provided the aggregate peak flow rate for each piece of equipment it is protecting has been considered. The system shall be plumbed with a bypass valve to allow isolation of filter housing to allow the bypass of untreated water in the event that service or cartridge replacement be necessary. Bypass is recommended but not required. The installation area should be suitable in size for the housing to be serviced without encumbrance.

The OneFlow® system must not require additional wastewater to backwash, flush, or regenerate once put into service. The system shall not require any chemical additives and shall not require electricity for operation.

NOTICE

The information contained herein is not intended to replace the full product installation and safety information available or the experience of a trained product installer. You are required to thoroughly read all installation instructions and product safety information before beginning the installation of this product.

*The wetted surface of this product contacted by consumable water contains less than 0.25% of lead by weight.

Watts product specifications in U.S. customary units and metric are approximate and are provided for reference only. For precise measurements, please contact Watts Technical Service. Watts reserves the right to change or modify product design, construction, specifications, or materials without prior notice and without incurring any obligation to make such changes and modifications on Watts products previously or subsequently sold.

Feed Water Chemistry Requirements

pH	6.5-8.5
Hardness (maximum)	30 grains (513 ppm CaCO ₃) *
Water Pressure	15 psi to 90 psi (1.03 bar to 6.2 bar)
Temperature	40° F to 100° F (5°C to 38°C)
Free Chlorine	<2 ppm
Iron (maximum)	0.3 ppm **
Manganese (maximum)	0.05 ppm **
Copper	1.3 ppm***
Oil & H ₂ S	Must be Removed Prior to OneFlow
Total Phosphates	< 3.0 ppm
Silica (maximum)	20 ppm †
TDS	1500 mg/l ††

NOTICE

* Systems using OneFlow® technology are effective at controlling lime-scale formation inside the plumbing system at influent hardness levels up to 30 grains per gallon (513 ppm CaCO₃) of calcium carbonate. Due to variances in water chemistry, 30 grains per gallon is a recommended hardness maximum due to potential aesthetic issues related to soft scale residue formation outside of the plumbing system. Testing should be performed to determine proper application where hardness levels exceed 30 grains per gallon.

**Just as with conventional water softening media, OneFlow® media needs to be protected from excess levels of certain metals that can easily coat the active surface, reducing its effectiveness over time. Public water supplies rarely, if ever, present a problem, but if the water supply is from a private well, confirm that the levels of iron (Fe) and manganese (Mn) are less than 0.3 mg/L and 0.05 mg/L, respectively.

⚠ WARNING

***Pursuant to the EPA drinking water standards, the copper concentration permitted is up to 1.3 ppm. Typically originating from new copper plumbing, high levels of copper can foul OneFlow media. New Copper lines need to be passivated for a minimum of 4 weeks before placing unit into service. For applications with copper concentration greater than 1.3 ppm, please consult Watts Water Quality Technical Service. To further minimize any problem with excess copper, avoid applying excessive flux on the inner surfaces of the pipe and use a low-corrosivity water soluble flux listed under the ASTM B813 standard.

NOTICE

† OneFlow® media does not reduce silica scaling. While silica tends to have a less significant effect on scale formation than other minerals, it can act as a binder that makes water spots and scale residue outside the plumbing system difficult to remove. This 20 ppm limitation is for aesthetic purposes.

†† All other contaminants must meet the requirements of the USEPA Safe Drinking Water Act. Specific Mineral and Metal MCL's, identified in Watts published Feed Water Chemistry Requirements, supersedes the USEPA SDWA.

Water known to have heavy loads of dirt and debris may require pre-filtration prior to OneFlow®.

System Specifications

Inlet/Outlet Connections: 3/4" FNPT

Nominal Flow Rate up to 6 gpm (22.71 lpm)

Gallon Rating (Continuous Flow Rate):

OFTWH-R: up to 4 gpm, 24/7/365 for 2 years for the OFTWH-RM-R cartridge.

Capacity: OFTWH-RM-R cartridge does not have a grain removal capacity, however, other contaminants present in the water will gradually degrade the effectiveness of this cartridge. Change the OFTWH-RM-R cartridge at least once every two years.

Standards

Independent scientific testing has confirmed Template Assisted Crystallization (TAC) technology provides scale reduction of over 95+%. Testing was conducted under protocol based on DVGW W512 test to assess control of scale formation.

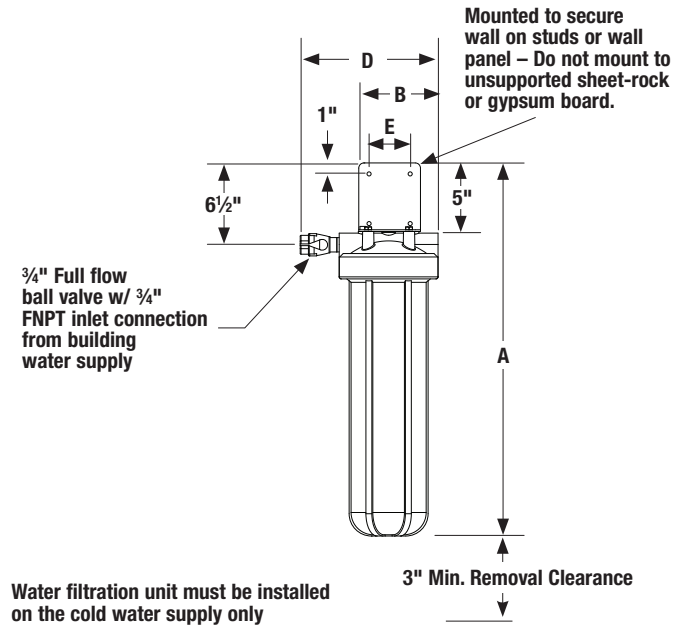
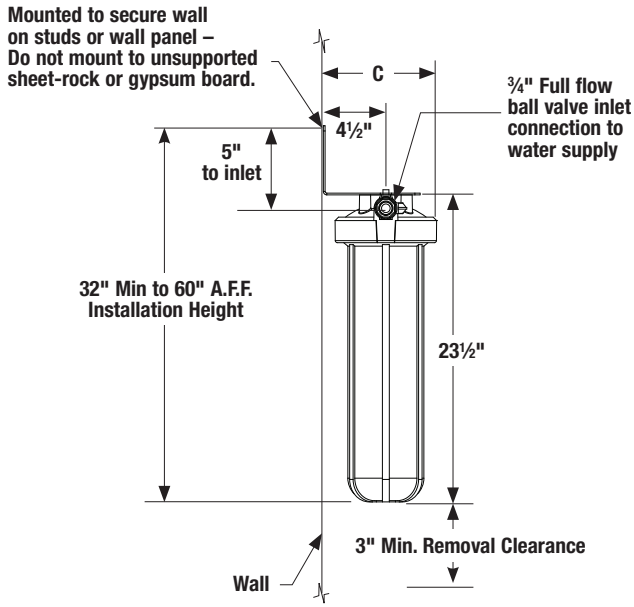

Dimensions – Weights

MODEL	DIMENSIONS						WEIGHT					
	A		B		C		D		E			
	in.	mm	in.	mm	in.	mm	in.	mm	in.	mm	lbs.	kgs
OFTWH-R	28 1/2	724	4 1/2	114	8 3/8	219	10	254	3	76	15	6.8

The overall height and the height of the inlet fitting varies due to material variations and assembly tolerances. Please allow additional clearance above the filter for making connections.



USA: T: (978) 689-6066 • F: (978) 975-8350 • Watts.com
 Canada: T: (905) 332-4090 • F: (905) 332-7068 • Watts.ca
 Latin America: T: (52) 55-4122-0138 • Watts.com