

Installation, Operation and Maintenance

1" Commercial Water Softeners

Series: PWS10

WATTS[®]
pure water



PWS10 Simplex Systems

WATTS[®]

Congratulations on your purchase of this Watts® commercial water softening solution.

You have made a great choice to protect your plumbing system against the damaging effects of hard water. This system has been engineered for trouble free operation and produced using top quality components. Simple programming, corrosion resistant mineral tank(s) and an easy to service design ensures this system will be durable and easy to maintain.

Thank You!

The Watts Team

Softened water provides a wide variety of benefits such as reducing the potential of lime scale formation in boilers, water heaters and heat exchangers to protecting the remainder of the plumbing system from costly maintenance and down time associated with the negative effects of hard water.

⚠ WARNING

Please read carefully before proceeding with installation. Your failure to follow any attached instructions or operating parameters may lead to the product's failure. Keep this Manual for future reference.

**⚠ WARNING**

If you are unsure about installing your Watts water softener contact a Watts representative or consult a professional water treatment dealer or plumber.

You are required to thoroughly read all installation instructions and product safety information before beginning the installation of this product. **FAILURE TO COMPLY WITH PROPER INSTALLATION AND MAINTENANCE INSTRUCTIONS COULD RESULT IN PRODUCT FAILURE WHICH CAN CAUSE PROPERTY DAMAGE, PERSONAL INJURY AND/OR DEATH.** Watts is not responsible for damages resulting from improper installation and/or maintenance. Local building or plumbing codes may require modifications to the information provided. You are required to consult the local building and plumbing codes prior to installation. If this information is not consistent with local building or plumbing codes, the local codes should be followed.

Save manual for future reference.

Refer to the enclosed for operating parameters to ensure proper use with your water supply.

- As with all plumbing projects, it is recommended that a trained professional water treatment dealer or contractor install the water conditioning system. Please follow all local plumbing codes for installing this water conditioning system.
- Inspect the water conditioning system for carrier shortage or shipping damage before beginning installation. Replace any damaged component immediately, before beginning installation.
- Use caution when installing soldered metal piping near the water conditioning system. Heat can adversely affect the system's components.
- Use only lead-free solder and flux for sweat-solder connections, as required by state, province and federal codes.
- Handle all components of the system with care. Do not drop, drag or turn components upside down.
- Be sure the floor under the system is clean, level and strong enough to support the system while in operation.
- Install the system in a protected area.
- Do not attempt to treat water over 110°F (43°C) or under 34°F (1°C) with the system.
- Always connect the system to the main water supply pipe before the water heater.
- Do not install in direct sunlight as overheating of electronics may occur and ultraviolet rays from the sun may cause damage.
- Operating ambient temperature: 34° to 100°F (1° to 43°C).
- Operating water pressure range : 25 to 125psi (171 kPa to 8.6 bar).
- All plumbing connections to the system should be made using industry accepted best practices. Plumbing tape or paste may be used on metal inlet and outlet plumbing connections. Do not use paste type pipe thread sealants on the system's plastic plumbing connections.

- Do not use petroleum-based lubricants such as Vaseline, oils or hydrocarbon-based lubricants on O-rings or valve seals. Use only 100% silicone lubricants.
- Use only the power transformer supplied with this water conditioning system.
- All electrical connections must be completed according to local codes.
- The power outlet must be grounded.
- For installations where plastic plumbing is used, install an appropriate grounding strap across the inlet and outlet piping of the building's metal plumbing to ensure that a proper ground is maintained.
- To disconnect power, unplug the AC adapter from its power source.
- Observe drain line requirements.
- Support the full weight of the plumbing system with pipe hangers or other means.
- Do not allow this water conditioning system to freeze. Damage from freezing will void this water conditioning system's warranty.
- It is established that when daytime water pressure exceeds 80psi (5.5 bar), the maximum pressure rating of 125psi (8.6 bar) can be exceeded. A pressure regulator must be installed on this system or warranty is voided.
- Periodic cleaning and maintenance is required for system to function properly.
- Observe all warnings that appear in this manual.
- Keep the media tank in the upright position. Do not turn upside down or drop. Turning the tank upside down or laying the tank on its side can cause media to enter the valve.
- Use only regenerants designed for water conditioning. Do not use ice melting salt, block salt or rock salt.

How To Use This Manual

This installation manual is designed to guide the installer through the process of installing and starting up this commercial water conditioning systems.

This manual is a reference and will not include every system installation situation. The person installing this equipment should have:

- Training on the control valve.
- Knowledge of water conditioning and how to determine proper control settings.
- Adequate plumbing skills.

⚠ WARNING

Do not use with water that is microbiologically unsafe or of unknown quality without adequate disinfection before or after the system.

Table of Contents	Page
Safety Information	3
How To Use This Manual	3
Introduction	4
Project Data Sheet	5
System Specifications	6-7
Set Up	8
Operating Parameters	8
System Installation	9-10
Start Up Instructions	10
Installation Diagrams	11
NXT2 & SXT Controller Electrical Connections	12
NXT2 & SXT Wiring Diagrams	13-14
NXT2 Controller Programming and Operation	15
NXT2 Controller Display	16
NXT2 Controller Operation	17
NXT2 Controller Features	18-19
NXT2 Master Programming Mode Flow Chart	20-21
NXT2 User Programming Mode Flow Chart	21
NXT2 Diagnostic Programming Mode Flow Chart	22
NXT2 Time of Day Programming Mode Flow Chart	23
NXT2 Programming Parameters and Ranges	24
SXT Controller Programming and Operation	25
SXT Controller Display	25
SXT Time of Day Programming	25
SXT Controller Operation	26
SXT Master Programming	27-31
SXT Diagnostic Programming Mode Flow Chart	32-33
Replacing the Media	34
Replacement Parts - Major System Components	35-36
Replacement Parts - 2750 Upper Powerhead	37
Replacement Parts - NXT2 Controller Assembly	38
NXT to NXT2 Conversion Kit	39
Replacement Parts- SXT Controller	40
Replacement Parts - 2750 Control Valve Body	41
Replacement Parts - 1600 Brine System	42
Replacement Parts - 1650 Brine System	43
Replacement Parts - 1"	
Electronic Plastic Turbine Meter Assembly	44
Replacement Parts- 1" Stainless Steel Electronic Meter	45
Troubleshooting	46-48
Water Softener Flow Diagrams - Down Flow	49
Flow Data and Injector Draw Rates - Down Flow	50
Injector Nozzle and Throat Chart for 1600 Brine Systems	50
Warranty	52

Introduction

Principals of Softening- Ion Exchange

In nature, water acts as a solvent that dissolves substances it comes in contact with such as solid rock. When water dissolves limestone rock, which is composed of calcium and magnesium, the solid calcium and magnesium become ions. This means they have been dissolved into the water and are now a liquid. An ion with a positive electrical charge is called a cation. Calcium and magnesium hardness ions in water are positively charged cations. When water dissolves enough calcium and magnesium hardness cations it is classified as hard water, which can cause lime scale build up in plumbing systems, water spots, and an increase in soap and cleaning product usage.

Ion exchange water softening is a process where an ion exchange resin is used to effectively exchange calcium and magnesium hardness cations for sodium cations in the water.

New, or freshly regenerated, ion exchange resin is saturated with sodium cations. As calcium and magnesium hardness cations come in contact with the ion exchange resin, they attach to the resin and sodium cations are released into the water. This is possible because the hardness cation are more attracted to the ion exchange resin than the sodium cations. Therefore, scale forming calcium and magnesium cations have been exchanged for non-scale forming sodium cations as the water is treated. If the calcium and magnesium content of the water is reduced to less than 17.1 mg/L, that water is classified as soft water.

Eventually the ion exchange resin will become exhausted, depleted of sodium, and will need to be regenerated with a sodium brine solution to restore its capacity to soften water. This system includes a flow meter to track treated water volume and initiate the regeneration process before resin exhaustion occurs.

Regeneration occurs automatically and consists of 5 steps:

Step 1- Backwash

Approximate Duration 10 Minutes- Fresh water flow is directed upward through the resin bed, to remove solid particles the resin bed has captured, sending them to drain.

Step 2- Brine Draw

Approximate Duration 15-20 Minutes- Brine water is drawn from the brine tank, rinsed over the ion exchange resin, driving away the calcium and magnesium cations and restoring sodium cations within the resin. Calcium and magnesium is sent to drain.

Step 3- Slow Rinse

Approximate Duration 40-45 Minutes- Once the brine tank is emptied of brine water, fresh water will continue to rinse over the resin and rinse calcium and magnesium cations to drain.

Step 4- Rapid Rinse

Approximate Duration 10 Minutes- After the conclusion of slow rinse, fresh water will rinse over the resin to ensure any residual sodium brine has been cleaned from the resin before it returns to service.

At the conclusion of Rapid Rinse:

Simplex single tank systems return to the "In Service" position. Multi tank systems remain in the "Stand By" position.

Step 5- Brine Tank Refill

Approximate Duration User Adjustable- In this final step of regeneration, water is added back into the brine tank so that a brine solution can be prepared for the next regeneration.

Project Data Sheet

Job Details

Job Number: _____

Model Number / Serial Number: _____

Water Hardness: _____ ppm or gpg

Capacity Per Unit: _____

Mineral Tank Size: _____ Diameter: _____ Height: _____

Salt Setting per Regeneration: _____

Regenerant Flow: _____ Upflow _____ Downflow _____

1. Meter Size:

A. ¾" Paddle Wheel

B. ¾" Turbine

C. 1" Paddle Wheel

D. 1" Turbine

E. 1½" Electronic Inline Plastic Turbine

F. 1½" Paddle Wheel

G. 2" Paddle Wheel: Stainless Steel _____ Brass _____ Plastic _____

H. Generic _____ Pulse Count _____ Meter Size _____

2. System Type:

A. System #4: 1 Mineral Tank, 1 Meter, Immediate, or Delayed Regeneration

B. System #7: 2 Mineral Tanks, 1 Meter, Immediate Regeneration

C. System #14: 2-8 Mineral Tanks, 2-8 Meters, Immediate Regeneration,

Progressive Flow Tank Staging- GPM Threshold for Progressive

Feature _____

D. _____ Other: System # Description _____

3. Controller Program Settings:

A. Backwash: _____ Minutes

B. Brine and Slow Rinse: _____ Minutes

C. Rapid Rinse: _____ Minutes

D. Brine Tank Refill: _____ Minutes

E. Pause Time: _____ Minutes

4. Drain Line Flow Control: _____ gpm

5. Brine Line Flow Control: _____ gpm

6. Injector Size#: _____

7. Water Pressure: _____

8. Water Temperature: _____

System Specifications

Dimensions - Weights

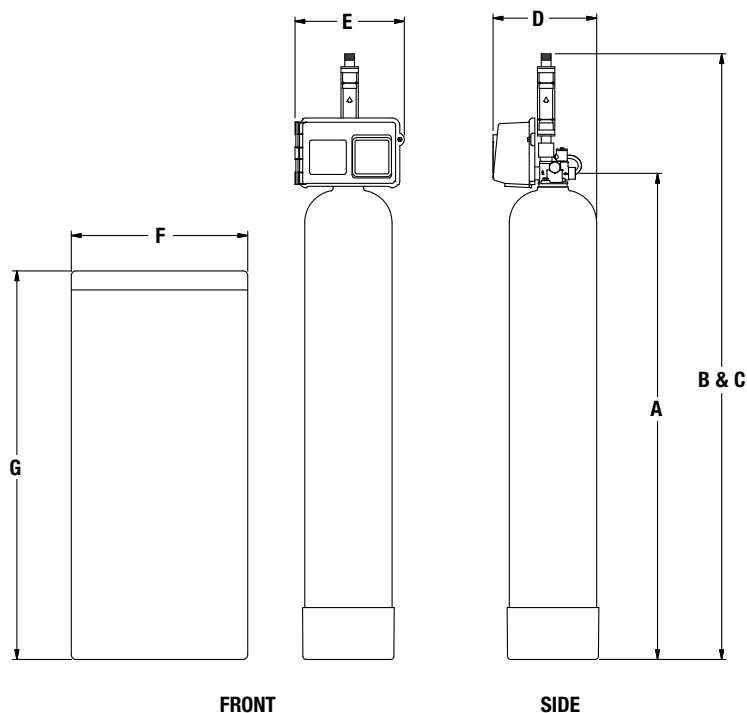

Series PWS10

MODEL NO.	DIMENSIONS														WEIGHTS	
	A		B		C		D		E		F		G		lbs.	kgs
	in.	mm	in.	mm	in.	mm	in.	mm	in.	mm	in.	mm	in.	mm		
PWS10111A11	50 ¹ / ₈	1273	64	1625	64	1625	11 ¹ / ₂	292	12 ³ / ₄	324	18	457	40	1016	116	53
PWS10111B11	56 ¹ / ₄	1429	70 ¹ / ₈	1781	70 ⁷ / ₈	1781	12	305	12 ³ / ₄	324	18	457	40	1016	136	62
PWS10111C11	54 ⁵ / ₈	1387	68 ⁷ / ₁₆	1738	68 ⁷ / ₁₆	1738	13	330	12 ³ / ₄	324	18	457	40	1016	196	89
PWS10111D11	67 ³ / ₈	1711	81 ¹ / ₄	2064	81 ¹ / ₄	2064	14 ¹ / ₈	359	14 ¹ / ₈	359	18	457	40	1016	240	109
PWS10111E11	66 ³ / ₄	1695	80 ¹ / ₂	2045	80 ¹ / ₂	2045	16 ¹ / ₈	409	16 ¹ / ₈	409	18	457	40	1016	320	145

Specifications

MODEL NO.	TANK SIZE	MINERAL TANK		BRINE TANK		SOFTENING CAPACITY		LBS. SALT PER REGENERATION		FLOW RATE & PRESSURE		
		RESIN Ft ³	GRAVEL	TANK SIZE	SALT FILL	MAX	MIN	MAX	MIN	SERV GPM	DROP PSI	BKW GPM
PWS10111A11	9" x 48"	1.0	10 lbs.	18" x 40"	400	30 K	20 K	15	6	9/15	15/25	2.0
PWS10111B11	10" x 54"	1.5	10 lbs.	18" x 40"	400	45 K	30 K	22.5	9	10/15	15/25	2.4
PWS10111C11	12" x 52"	2.0	30 lbs.	18" x 40"	400	60 K	40 K	30	12	15/20	15/25	3.5
PWS10111D11	14" x 65"	3.0	60 lbs.	18" x 40"	400	90 K	60 K	45	18	18/23	15/25	5.0
PWS10111E11	16" x 65"	4.0	80 lbs.	18" x 40"	400	120 K	80 K	60	24	19/25	15/25	7.0

System Specifications

General System Information for 1" Simplex (PWS10) Softeners

Ordering Information

MODEL NO.	ORDERING CODE	DESCRIPTION	PIPE SIZE	SPACE REQUIRED D X W X H	WEIGHT	
					LBS.	KGS
PWS10111A11	7100020	1 Cubic Foot Simplex Softener with Flow Meter	1"	18" x 32" x 64"	116	53
PWS10111B11	7100021	1.5 Cubic Foot Simplex Softener with Flow Meter	1"	18" x 33" x 71"	136	62
PWS10111C11	7100022	2 Cubic Foot Simplex Softener with Flow Meter	1"	18" x 35" x 69"	196	89
PWS10111D11	7100023	3 Cubic Foot Simplex Softener with Flow Meter	1"	18" x 40" x 82"	240	109
PWS10111E11	7100024	4 Cubic Foot Simplex Softener with Flow Meter	1"	18" x 40" x 81"	320	145

Notes: Capacities are based on resin manufacturer's data and are dependent upon influent water TDS, temperature, bed depth, and flow rates. Feed water must be free of oil and color. Pipe size, tank size, and space requirements are in inches. Capacities and flow rates expressed above are per tank. Flow rates listed at 25psi drops are for intermittent peak flow rates and are not to be used as continuous flows.

Set Up

Unpack system and make sure all components are accounted for according to the diagram below according to your specific series number. If any components are missing or damaged contact your Watts representative. If they can not be reached contact Watts customer service at 1-800-224-1299.

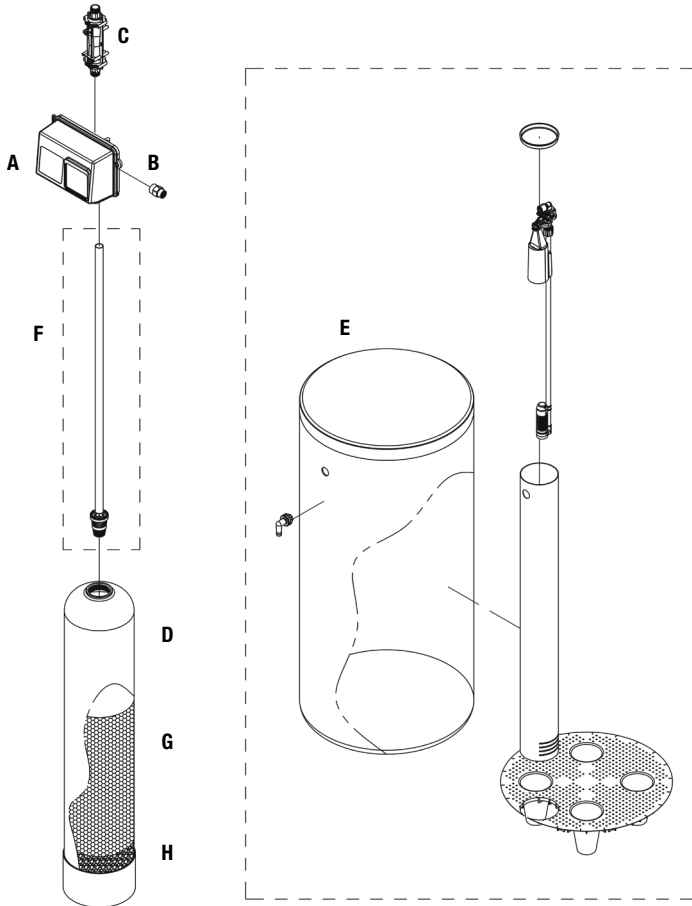

Operating Parameters

pH	6 to 10
Hardness (maximum)	Depends on customer's acceptable hardness leakage level
Water Pressure	25psi to 125psi (171 kPa to 8.6 bar)
Temperature	34 - 110°F (1 - 43°C)
Free Chlorine (maximum)	1mg/L
Iron (maximum)	1mg/L
Oil and H2S	None Allowed
Turbidity	Less than 5.0 NTU
Total Dissolved Solids	Must be below 750mg/L for the softener to produce less than 1 grain per gallon soft water
Minimum Ambient Temperature	34°F/1°C
Maximum Ambient Temperature	120°F/52°C
Maximum Humidity	75%
Power Supply Input Voltage	100-240 VAC
Power Supply Input Frequency	50/60 Hz
Power Supply Output Voltage	24 VDC
Power Supply Output Current	2.7 amps (per control valve)
Maximum Altitude	2,000 meters above sea level
Water known to have heavy loads of dirt and debris may require pre-filtration prior to the water softening system.	
For all other guideline information please contact your Watts representative.	

QUANTITY OF MAJOR COMPONENTS		
COMPONENT LABEL	COMPONENT	PWS10 SIMPLEX
A	Number of Control Valves	1
B	Number of Drain Line Flow Controllers*	1
C	Number of Flow Meters	1
D	Number of Mineral Tanks	1
E	Number of Brine Tanks	1
F	Number of Distributor Tubes*	1
G	Resin**	Quantity Varies Depending On System Size
H	Gravel**	Quantity Varies Depending On System Size

* Drain line flow controllers may come factory assembled on control valve's drain port depending on size. Distributor tubes ship inside mineral tanks.

** Water softening systems that use mineral tanks larger than 12" in diameter are not factory loaded with resin and gravel. For unloaded systems, the media is in bags and ship on the system pallet. The proper amount of media is supplied for the mineral tank used.

System Installation

Pre-Installation Considerations

- A minimum of 25psi of water pressure is required for regeneration valve to operate effectively.
- A continuous 115 volt, 60 Hertz current supply is required. Make certain the current supply is always hot and cannot be turned off with another switch.
- Condition of existing plumbing should be free from lime and iron buildup. Piping that is built up heavily with lime and/or iron should be replaced. If piping is clogged with iron, a separate iron filter unit should be installed ahead of the water softener.
- The softener should be located close to a drain.
- Always provide for the installation of a bypass valve.
- The full weight of the plumbing system must be supported by pipe hangers or other means.
- Do not install the system where it would block access to the water heater, main water shutoff, water meter, or electrical panels.
- Install the system in a place where water damage is least likely to occur if a leak develops.
- If applicable, use di-electric unions where dissimilar metals are present.

NOTICE

The main control valve and all plumbing connections have right-hand threads. Turn clockwise to install.

NOTICE

If O-ring lubricant is required, only use a silicone based compound formulated for potable water O-ring applications. Watts recommends Ordering Code #7300948 Silicone Lubricant. The use of other types of lubricants may attack the control's plastic or rubber components. Petroleum-based lubricants can cause swelling in rubber parts, including O-rings and seals.

WARNING

Do not exceed water pressure of 125psi (8.6 bar). Do not exceed 110°F (43°C). Do not subject unit to freezing conditions.

General Installation Instructions

NOTICE

Installation diagrams and additional details are available on pages 11-14 of this manual.

1. Turn off water heater(s).
2. Turn off the main water supply to the building and open a treated water faucet (cold and hot) to relieve any pressure within the plumbing system.
3. Place the mineral tank into its final position for installation. Make sure that the location is level and sturdy enough to support the weight of the system once it is in operation.
4. Unloaded mineral tanks will need to be loaded with resin and gravel media following the instructions below:
 - 4a. Inspect the distributor screen for damage, and make sure the screen is present before loading the mineral tank with media. Before proceeding with installation, replace any damaged components immediately.

NOTICE

If a 4" X 2½" PVC tank bushing is included with the system to adapt the control valve base to a larger control valve tank connection, ensure the bushing is tightened, fully hand tight, into the tank at this time.

- 4b. Cap the top open end of the distributor tube with tape and plastic sheeting to keep all media and foreign debris from entering the distributor tube. This cap must be secure and not come off during media loading.
- 4c. Place the distributor tube, screen end down, into the mineral tank and center it in the bottom. The top of the distributor tube should be flush with the top of the tank. Test the tape cap to make sure it can not come off during the media loading process.
- 4d. Make sure the plastic and tape cap is secure to the top of the distributor tube, place a funnel on the top of the tank and load first the gravel then the softening resin into the tank. The cap must not come off of the distributor tube during the loading of the media.
- 4e. Remove the funnel from the top of the tank and plastic cap and tape from the top of the distributor tube. DO NOT PULL UP ON THE DISTRIBUTOR TUBE when removing the cap. The distributor tube top must remain flush with the top of the tank.
- 4f. Clean any media from the threads and top of the mineral tank. Media in the threads and on the O-ring sealing surface of the tank can cause tank thread damage and prevent the control valve's O-ring seal from sealing properly.
- 4g. Lubricate the O-rings on the bottom of the control valve (distributor tube port O-ring and top of tank O-ring). Use nonpetroleum based silicone lubricant only.
- 4h. Place the control valve on top of the tank. When performing this step, seat the top of the distributor tube inside the distributor port located on the bottom of the control valve first, then press the control valve down until the control valve threads come in contact with the tank threads. This ensures that the distributor tube is properly seated into the bottom of the control valve.
- 4i. Tighten the control valve onto the tank with a clockwise rotation. Be careful not to cross thread the control valve to tank connection or over tighten it. A hand tight fit is appropriate for the control valve torque. DO NOT use a wrench. Tank or control valve damage could result. DO NOT apply thread sealant or plumbing tape on the control valve to tank threaded connection.

5. Apply a suitable thread sealant to the male threads of the flow meter and with the meter's direction of flow arrow pointing in the direction of water flow, install the meter directly into the outlet port of the system control valve.
6. Rotate meter clockwise to tighten, by gripping the meter on the end connector that attaches to the control valve with a wrench, and continue to tighten the flow meter end connector until tight. Then rotate plastic meter body so the meter cable can be aligned and inserted into the meter's cable port. DO NOT grip on the plastic meter body with the wrench when installing the flow meter.

System Installation

7. Connect the cold water supply to the inlet port of the water softening system's control valve. When constructing the supply line, install an inlet water isolation valve and plumbing union fitting (user supplied) in the supply line of the control valve and close the isolation valve. The union fitting should be located between the isolation valve and the system's inlet port.
8. Install an inlet water sample port in the supply line and close it.
9. If risk of vacuum exists, install Watts # 0556031 vacuum relief valve in the supply line to protect the system against vacuum damage.
10. Connect the outlet water connection of the water meter to the water line requiring softened water. When constructing this outlet water line, install an outlet water isolation valve and plumbing union fitting (user supplied) in the outlet line and close the isolation valve. The union fitting should be located between the outlet of the control valve and the outlet isolation valve.
11. Install an outlet water sample port on the outlet water line of the system and close it.
12. Install a bypass valve between the inlet and outlet plumbing water lines and close it.
13. If not already factory installed on the control valve, attach the drain line flow controller directly to the control valve's drain port. See page 11 for Drain and Brine Connection Detail. The flow arrow on the drain line flow controller must point towards the drain receptacle. Only plumbing tape is allowed on the drain line flow controller fitting threads.

⚠ WARNING

Operating a system without a drain line flow controller will cause all media to flow out of the system through the drain line.

14. Construct the drain line routing it to an appropriate drain receptacle abiding by all local building and plumbing codes. DO NOT construct drain line to elevations that exceed 4 feet above the drain port of the control valve, or reduce the drain line diameter to smaller than that of the drain line flow controller. Install a plumbing union fitting in the drain line close to the drain line flow controller. The drain line must be anchored to the floor.
15. Connect the brine tank to the water softener's control valve brine port using the factory supplied fittings and tubing. See page 11 for Drain and Brine Connection Detail. The brine tank should set on a common elevation as the mineral tank and within distance so that it can be reached by the length of factory supplied brine tubing. Add enough water (6") to the brine tank so that water covers the top of the air check. DO NOT add salt to the brine tank at this time.
16. Insert the meter cable's sensor into the sensor port in the meter dome according to Figure 1. Connect the plug end of the meter cable wire into the P1 port for SXT controller (See page 14 for location) and P5 port for NXT2 controller (See page 13 for location).
17. Connect the 24V transformer power supply wires to the control valve controller. Connect wires into the P2PWR port for SXT controller (See page 14 for location) and P14 port for NXT2 controller (See page 13 for location).
18. If applicable, install a metal bonding strap across metal inlet and outlet plumbing lines to maintain electrical continuity.

The system is now ready for Start Up.

Start Up Instructions

1. Ensure all inlet and outlet isolation valves and the bypass valves are in the closed position and the treated water faucet hot and cold side are in the open position.
2. Open the main water supply valve to the building.
3. Check for leaks and repair as needed.
4. Plug the power cord of the control valve into an electrical outlet to energize system.
5. Locate "Manually Initiating a Regeneration" in this manual and follow the steps to place the system in the backwash position. For SXT Controller reference page 26, for NXT2 Controller reference page 17.
6. Open the inlet isolation valve slightly until water can be heard flowing through the isolation valve and allow the mineral tank to fill with water. Air will come out of the drain line until the mineral tank is full of water. Once water flow at the drain line is observed, fully open the inlet valve and allow water flow to drain for 10 minutes to flush the resin bed of any color. If water at the drain shows any discoloration, continue to flush the resin bed until water at the drain is clear.
7. After resin bed flushing is complete, plug the system back in to the power outlet and return the control valve to the service position by advancing through each step of regeneration by pressing the extra cycle button. See Manually Initiating a Regeneration for help.
8. Program the system according to the System Type following the Control Valve Programming section of this manual. SXT Control Valve Programming begins on page 25, NXT2 Control Valve Programming begins on page 15.
9. Put the appropriate amount of water in the brine tank. This is accomplished by manually cycling the control valve to cycle step 4 "Brine Tank Refill" and allowing a complete brine tank refill cycle to conclude.
10. Put the appropriate amount of salt in the brine tank. Do Not fill the salt level past the brine well lid.
11. Fully open the outlet isolation valve.
12. Ensure the bypass valve is in the closed position.
13. Check for leaks and repair as needed.
14. Allow water to flow from the hot and cold side treated faucet until all air has been purged from the plumbing system. Then close both the hot and cold side treated water faucet.
15. Turn on water heaters.

Start up is now complete and the system is ready for operation.

Figure 1 Plastic Meter & Stainless Steel Meter

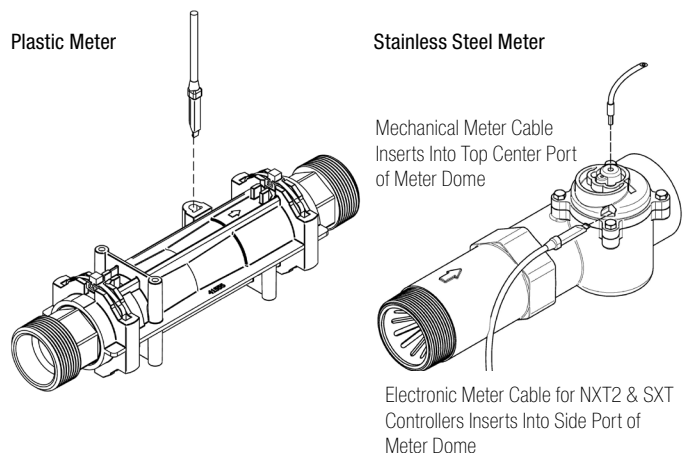

Installation Diagrams - Series PWS10 Simplex Systems

Installation Reference Notes For All System Installation Drawings:

1. All dimensions are on page 6 of this manual & unless otherwise noted & are ± 1 inch (25mm).
2. All items shown in phantom line are to be provided by others.
3. All dimensions are subject to change without any notice.
4. Install unions fittings on inlet, outlet & drain plumbing connections.
5. Provide a 2 feet minimum clearance above mineral tank for filling media.
6. A GFCI equipt electrical outlet should be provided within 5 feet of equipment location.
7. Use dielectric unions on plumbing connections of control valve when dissimilar metals are present.
8. Provided system shall not be subject to any vacuum. If risk of vacuum is present, install siphon break on drain line & install vacuum relief valve watts ordering code # 0556031 on inlet line.
9. Brine tank dimensions shown on table are factory selected for use with the specified system size.
10. Do not install drain line directly to a drain. For proper drain connection follow all national, state and local codes. Do not construct drain line to elevations that exceed 4 feet above the control valve's drain port.
11. The full weight of the piping and valves must be supported by pipe hangers or other means.
12. Inlet and outlet headers need to be sized according to flow rate requirements by others.
13. Power requirements: 115v/60hz 2.7 amps per control valve unless otherwise specified.
14. Brine tank must be located within 10 feet of system control valve and on a common floor elevation with mineral tank to ensure proper brine draw operation.
15. Use factory supplied brine tubing. Do not use smaller diameter tubing than what is supplied.
16. Limit inlet pressure to not exceed maximum published operating pressure.

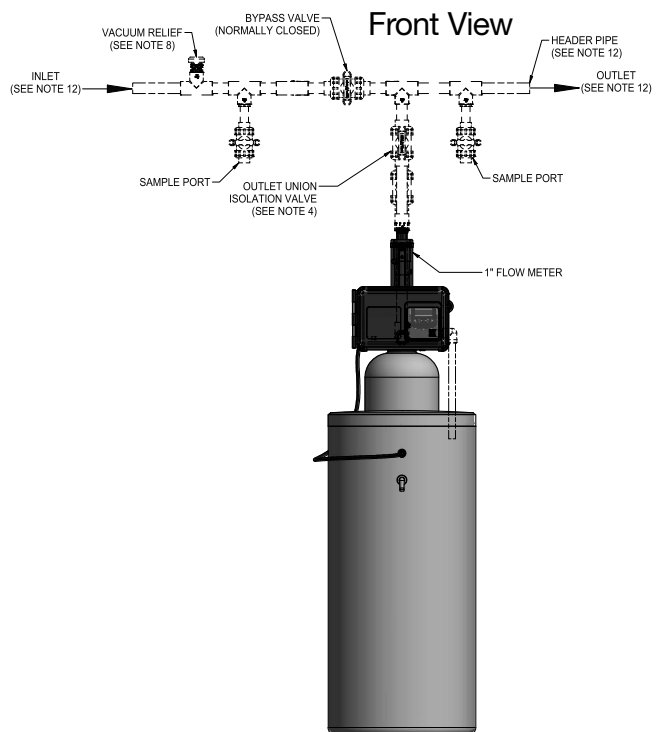
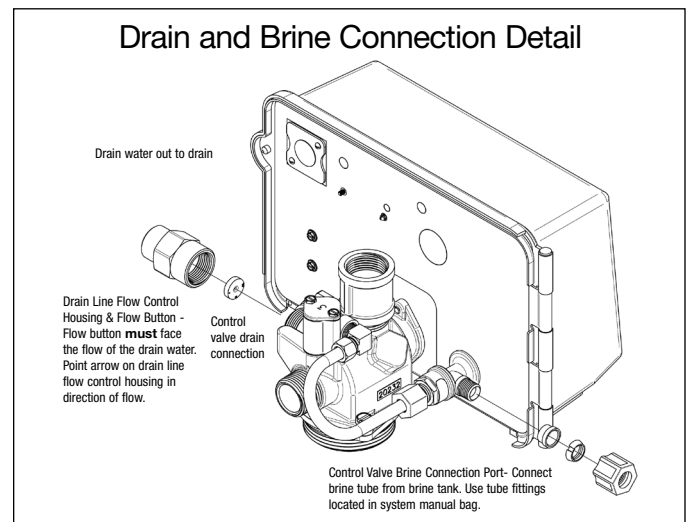
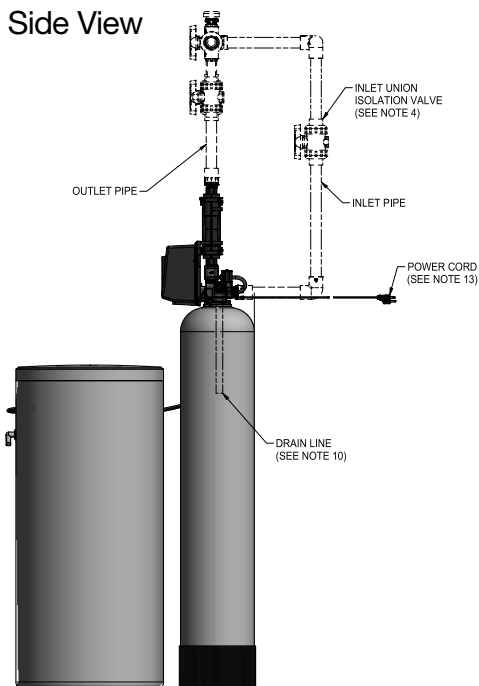
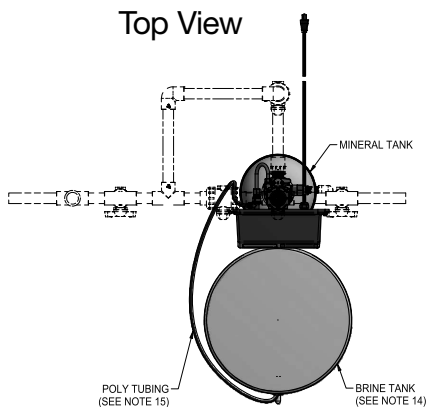

Controller Electrical Connections - NXT2

Power Supply Connections

Installing the Power Supply:

Note: Power Supply includes a harness with 2 black wires that connect to circuit board, see page 15.

1. Insert black and black transformer wires into 24VDC input of control.

Network / Communication Cables and Connections

Use a shielded CAT5 Network/Communication cable.

Connect the network/communication cable first before programming.

Cable length between timers/units should not exceed 25 feet.

Connect each unit in series (do not form a loop) together from one communication port to the next communication port. It does not matter which one goes to the next one.

2510/2750/2815/2850/2900 Valves*:

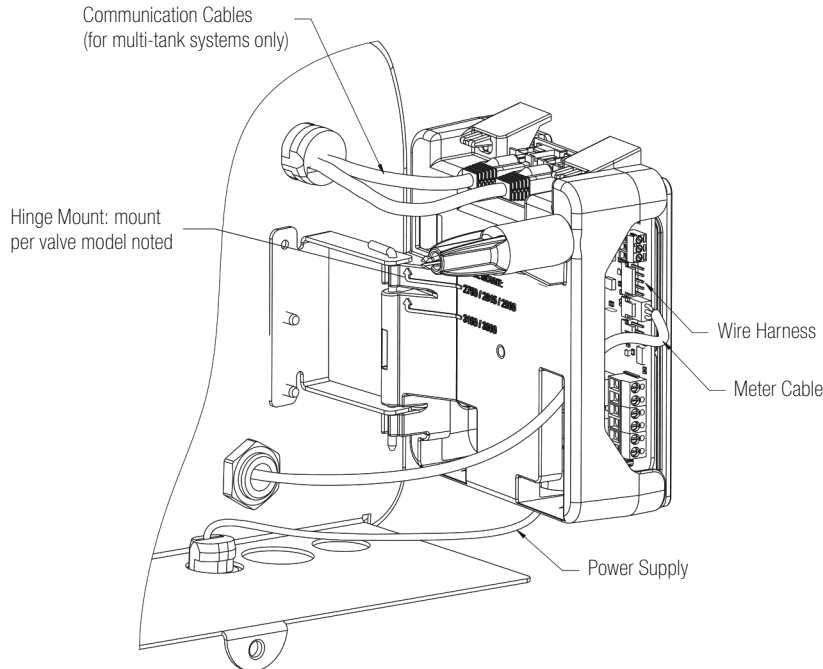

44404 Rev A

3150/3900 Valves:

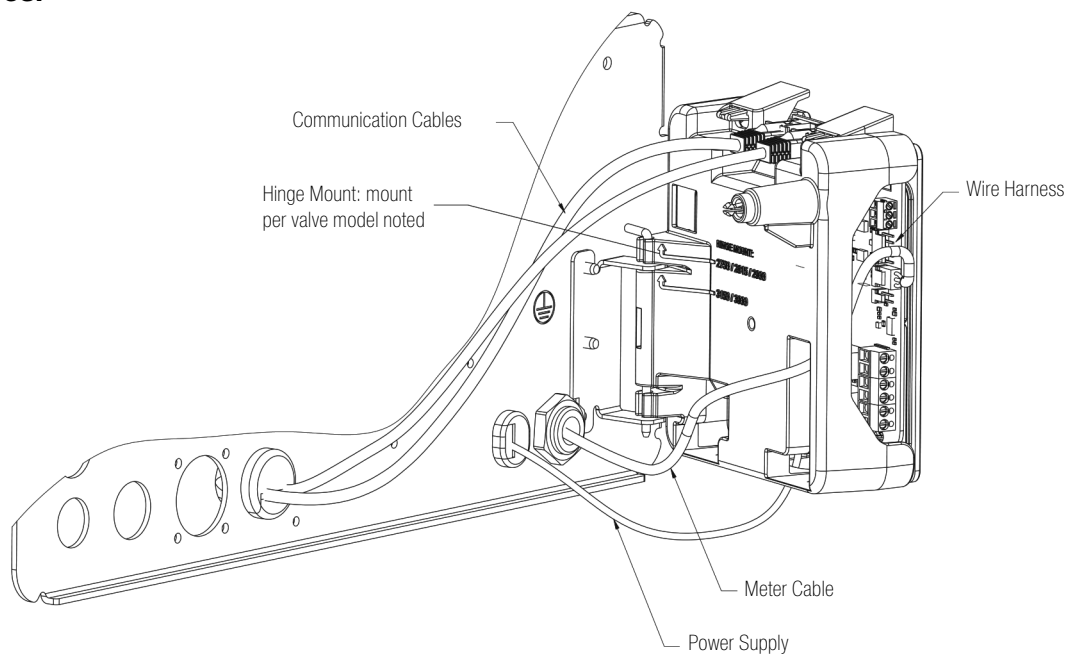

44403 Rev A

*PWS10 Systems use 2750 Type Control Valves.

Wiring Diagram - SXT

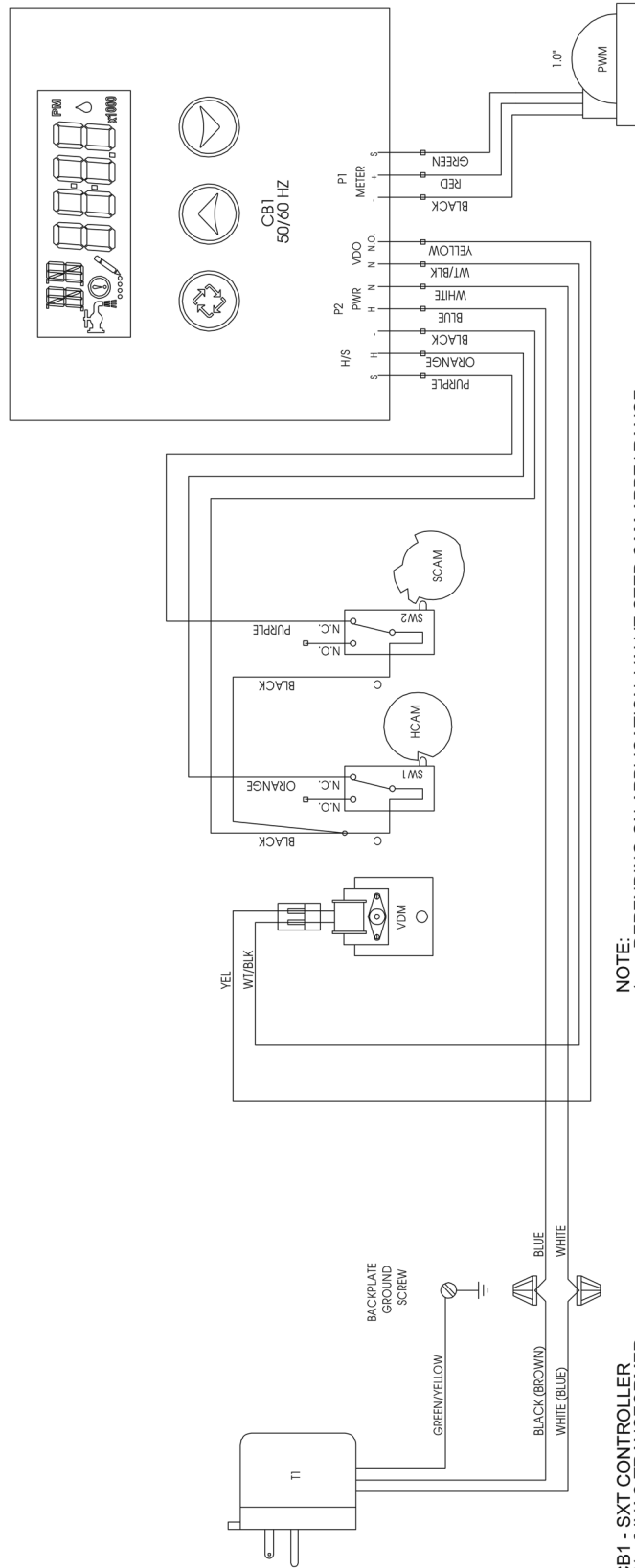

- NOTE:**
1. DEPENDING ON APPLICATION, VALVE STEP CAM APPEARANCE WILL VARY
 2. REGARDLESS OF CAM TYPE USED, WIRING TO SWITCHES SW1 AND SW2 WILL REMAIN AS SHOWN.
 3. VALVE SHOWN IN SERVICE POSITION.

- CB1 - SXT CONTROLLER
- T1 - 24VAC TRANSFORMER
- K1 - 24VAC VALVE DRIVE RELAY
- PWM - 1.0" OR 1.5" PADDLE WHEEL FLOW METER (OPTIONAL)
- VDM - VALVE DRIVE MOTOR
- SW1 - VALVE HOMING SWITCH
- SW2 - VALVE STEP SWITCH
- HCAM - VALVE HOMING CAM
- SCAM - VALVE STEP CAM

NXT2 Controller Programming and Operation

NOTICE

Check your system to verify controller type and reference the appropriate section of this manual. NXT2 controller section begins on this page, SXT controller section begins on page 25.

The NXT2 controller is capable of operating single or multi-tank systems.

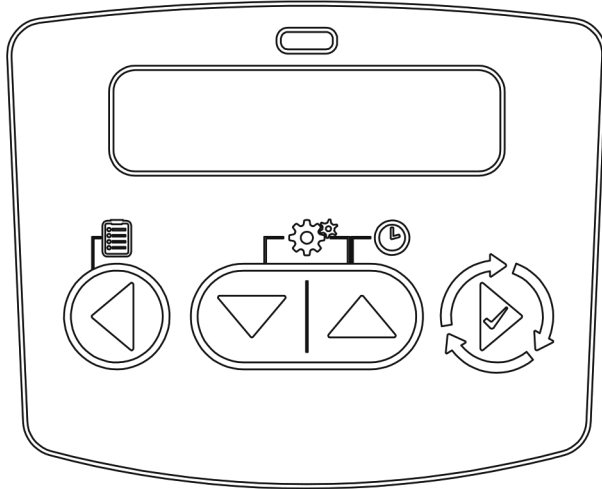

Modes of Operation

System Type	4 - Single Unit 5 - Parallel Interlock (2-8 Unit) 6 - Parallel Series Regeneration (2-8 Units) 7 - Alternating Interlock (2 Units) 8 - Alternating Delayed (2 Units) 9 - Alternating with Standby Units (2-8 Units) 14 - Progressive Demand Recall (2-8 Units)
Valve Type*	2510 2750 2815 2850 2900S 2910 (Europe only) 3150 3900
Regeneration Type	Softener/Filter Meter Delayed Softener/Filter Meter Immediate Time Clock Day of the Week Remote Regeneration
Regeneration Flow	Downflow Upflow Filter

Features

On-screen multilingual support: English, Francais, Deutsch, Italiano, Espanol, Nederlands, Portugues

- Time of day super capacitor backup for 12-hour power loss
- 2 to 4 line scrolling text OLED display, high contrast easy to read in low light conditions and at a distance
- Full functional user interface with easy programming allowing forward and backwards menu navigation
- Network two to eight valves via shielded CAT5 cables
- LED Status Indicator
 - Blue: In Service
 - Flashing Blue: Regeneration Queued
 - Green: Regeneration
 - Flashing Green: Standby
 - Red: Error condition present
- Two Programmable Auxiliary relay outputs
 - Time-based
 - Volume based (Chemical pump)
 - Alarm-based
 - Cycle-based
 - Standby
- Remote input
 - Remote Lockout
 - Remote Regeneration
- Easy installation with plug-in wiring harnesses
- Assistance Name and Phone Number contact fields
- Error Log History
- Water Usage Daily (up to 13 weeks)
- Push Settings
- Capacitive Touch buttons
- Two Regeneration Lockout Windows
- Reset to factory default settings or from saveable custom settings
- Full calendar display
- Master Programming Lockout
 - Code-based
 - Time-based
 - Delayed
- Icons for easy system status identification
- Dynamic network addressing
- Diagnostics
 - Real-time Flow Rate
 - Peak Flow Rate (can be reset)
 - Totalizer (can be reset)
 - Reserve Capacity
 - Use Since Last Regeneration
 - Last Regeneration
 - Identifiable Software Version
 - Total Number of Regenerations
 - Regeneration Interval
 - Last Settings Change
 - Error Log History
 - Average Daily Usage (per weekday, 3 month history)

*PWS10 Systems use 2750 Type Control Valves.

NXT2 Controller Display

System Number Network Indicator Valve State Flow Indicator Status LEDs Master Indicator Time of Day

Blue LED
On - Unit in Service
Blinking - Regeneration Queued

Green LED
On - Unit in Regeneration
Blinking - Unit in Standby

Red LED
On - Error present

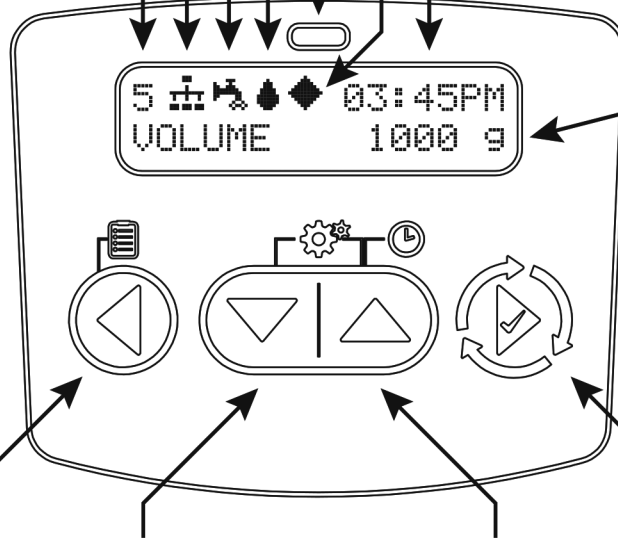

Display Screen
Alternates between Date, Flow Rate, and Volume Remaining (If a regeneration is queued, displays time until regeneration)

<p>Left Button Press: Navigate to previous menu option</p> <p>Press and Hold: Enter Diagnostic menu</p>	<p>Down Button Press: Adjust menu value down</p> <p>Press and Hold: Enter Time of Day menu</p>	<p>Up Button Press: Adjust menu value up</p> <p>Press and Hold: Enter Time of Day menu</p>	<p>Extra Cycle Button Press: Navigate to next menu option</p> <p>Press and Hold: Initiate a regeneration</p>
<p>Left Button + Down Button Press and Hold - Enter Master Programming</p>	<p> Down Button + Up Button Press and Hold - Enter User Programming</p>		

Display Icons

	Valve State: Service		Lock Window
	Valve State: Standby		Initializing
	Flow Indicator (flashing)		Upper Drive Movement
	Regeneration		Lower Drive Movement
	Master Unit (auto-assigned)		Remote Regeneration
	Network Indicator - Connected		Master Programming
	Network Indicator - Disconnected		User Programming
	Network Indicator - Unit Missing		Diagnostics
	USB Connected (Field Programmer)		Time of Day Programming
	Error Condition Present		
	Remote Lock		

NXT2 Controller Operation

Setting the Time of Day

Note: Set Time of Day on any unit and the rest of the units in the system will update the Time of Day automatically.

1. Press and hold the Up button for 2 seconds. The “Time” value is displayed. Press the Up or Down buttons to adjust as desired.
2. Press the Extra Cycle button to advance to the “Year” field. Press the Up or Down buttons to adjust as desired.
3. Press the Extra Cycle button to advance to the “Month” field. Press the Up or Down buttons to adjust as desired.
4. Press the Extra Cycle button to advance to the “Calendar Day” field. Press the Up or Down buttons to adjust as desired.
5. Press the Extra Cycle button to return to the normal display screen.

NOTE: Press and hold the Left button to exit without saving.

Manually Initiating a Regeneration

1. When controller is In Service or Standby, press and hold the Extra Cycle button on the main screen.
2. The controller advances to Regeneration Cycle Step #1, and begins programmed time count down.
3. Press the Extra Cycle button once to advance valve to Regeneration Cycle Step #2 (if active).
4. Press the Extra Cycle button once to advance valve to Regeneration Cycle Step #3 (if active).
5. Press the Extra Cycle button once to advance valve to Regeneration Cycle Step #4 (if active).
6. Press the Extra Cycle button once to advance valve to Regeneration Cycle Step #5 (if active).
7. Press the Extra Cycle button once more to advance the valve back to In Service.

NOTE: A manually initiated or queued regeneration can be cleared by pressing and holding the Back button. A system queued regeneration can only be cleared by stepping through a manual regeneration. If regeneration occurs for any reason prior to the delayed regeneration time, the manual regeneration request shall be cleared. Pressing the Extra Cycle button while in regeneration will cause the upper drive to advance to the next step immediately.

Controller Operation During Regeneration

In the Regeneration Cycle step display, the controller shows the current regeneration cycle name the valve is in, or has reached, and the time remaining in that step. Once all regeneration steps are complete, the controller returns to In Service and resumes normal operation.

CYCLE 1/5	
BACKWASH	00:10:00

CYCLE 2/5	
DRAW	00:60:00

CYCLE 3/5	
RAPID RINSE	00:10:00

CYCLE 4/5	
TANK REFILL	00:12:00

CYCLE 5/5	
PAUSE	00:00:00



Press the Extra Cycle button during a system queued Regeneration Cycle to immediately advance the valve to the next cycle step position and resume normal step timing.

Controller Operation During Programming

The controller enters the Program Mode in Standby or Service Mode as long as it is not in regeneration. While in the Program Mode, the controller continues to operate normally monitoring water usage. Controller programming is stored in memory permanently.

Controller Operation During A Power Failure

All program settings are stored in permanent memory. Current valve position, cycle step time elapsed, and time of day are all stored during a power failure, and will be restored when power is re-applied. Time is kept during a power failure, and time of day is adjusted upon power up (as long as power is restored within 12 hours).

NOTE: The time of day on the main display screen will flash for 5 minutes when there has been a power outage. The flashing of the time of day can be stopped by pressing any button on the display.

Flow Meter Equipped Controller

As treated water is used, the Volume Remaining display counts down from the calculated system capacity to zero. When zero is reached, a Regeneration Cycle begins if no other units are in regeneration.

NXT2 Controller Features

Remote Lock

The controller does not allow the unit/system to go into Regeneration until the Regeneration Lockout Input signal to the unit is cleared. This requires a contact closure to activate the unit. The recommended gauge wire is 16 AWG with a maximum wire length run of 50 feet.

Regeneration Day Override Feature

If the Day Override option is turned on and the valve reaches the set Regeneration Day Override value, the Regeneration Cycle starts if no other unit is in Regeneration. If other units are in regeneration, it is added to a regeneration queue. This occurs regardless of the remaining volume available.

Lock Settings (access to Master Programming)

Lock Settings prevents the user from accessing Master Programming. In Master Programming, select the desired Lock Settings option (Off, Time Based, Delayed, or Enter Code).

Time Based - User must set clock to 12:01 pm to unlock

Delayed - User must press and hold the Left and Down buttons for 60 continuous seconds to unlock

Enter Code - User must input code "1201" to unlock

Capacitive Buttons

Capacitive button entry warrant different consideration than tactile button entry. Do not wear gloves. Be sure to keep your hands and the capacitive buttons free of debris, grease, or water. Buttons may become temporarily unresponsive if environmental conditions change such as sudden humidity or temperature changes. If buttons become unresponsive, wait 5 to 10 minutes for the buttons to recalibrate.

LED Status indicator

Blue - Unit in Service

Flashing Blue - Regeneration Queued

Green - Unit in Regeneration

Flashing Green - Unit in Standby

Red - Error with codes

Power Loss Backup

Time of day super capacitor backup for power loss; rated to last minimum 12 hours

Continuous Flow Detect

Alert appears when specified continuous flow rate is detected during service over a specified duration. Continuous flow rate is adjustable from 0.1 to 99999.9 GPM/LPM (accuracy of flow rate detected will vary based on capability of meter). Duration range is adjustable from 1 to 255 hours.

Remote Regeneration

Ability to trigger a regeneration via a remote input.

Regeneration Types

Softener/Filter Meter Delayed - When volume remaining reaches zero and the scheduled regeneration time is reached (default 2 a.m. softener; 12 a.m. filter), the unit will regenerate.

Softener/Filter Meter Immediate - When volume remaining reaches zero, the unit will regenerate.

Time Clock - Once volume remaining reached zero and the selected regeneration time is reached (default 2 a.m. softener; 12 a.m. filter), the unit will regenerate.

Day of the Week - Once volume remaining reaches zero and the selected Day of the Week is reached, the unit will regenerate.

Remote Regeneration - Remote Regeneration is accomplished by a 3rd party device completing a contact closure connected to the remote regeneration input connector. The 3rd party device must complete the signal duration time that was set in the duration signal time in programming to start a regeneration. You can set the remote regeneration for immediate regeneration or delayed regeneration at the set time that was programmed for regeneration time in programming.

Reset to Factory Defaults

While powering up the unit, when the Pentair Diamond logo® logo appears, press and hold the Extra Cycle button to access the Reset menu then select Reset to Factory Defaults. Press the Extra Cycle Button to confirm your selection and to advance to the service screen. Furthermore, you may select Reset to Non-Factory Defaults to save a set of unique control parameters.



Power on the unit. When Pentair logo appears, press and hold the Extra Cycle button. The Reset menu appears.

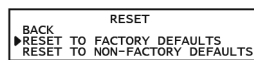

Use the up/down buttons to select.



Press the Extra Cycle button to set the desired option and return to the Service screen.



END

Lock Window

Lock Window prevents the unit from regenerating during a specified time frame. Two lock windows are available (Lock Window #1 and Lock Window #2). In Master Programming, enable a Lock Window then select the desired Lock Start time and Lock End time.

Settings Review

To prevent unintentional changes to Master Programming, enable Settings Review to view and navigate through Master Programming settings without the ability to edit.

The Pentair Diamond logo® is a trademark owned by Pentair plc or its affiliates.

NXT2 Controller Features

Push Settings

The ability to transmit user settings from one unit to all other connected units. Select the desired Master Programming settings on one unit then push the same settings to all other connected units. After the push settings have completed, you may still make unique changes to individual units.

Auxiliary Relays

The NXT2 has two auxiliary relays that may be activated based on cycle, time, or volume.

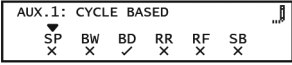
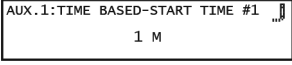
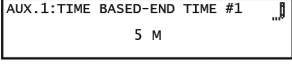
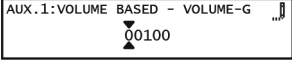
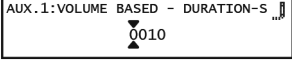
	Activates during selected cycle step
	Activates upon selected start time (Range: 0-91 minutes)
	Deactivates upon selected end time (Range: Start Time plus 1 minute)
	Activates when selected volume (gallon) is reached (Range: 0-99999)
	Selected duration in seconds (Range: 0-9999 seconds)

System 4 - Single Unit

Single Tank configuration Time Clock: No Meter Immediate:
One Meter Delayed: One Meter Remote Signal Start

System 5 (2-8 Units) Parallel Interlock)

All tanks in parallel supplying treated water. Each unit in the system will have its own flow meter/sensor input. The control will delay the start of Regeneration if another unit is already in Regeneration. Once that unit has completed a Regeneration cycle, and has returned to Service, the unit with the longest regeneration queue time will begin Regeneration. No more than one unit will be in Regeneration at a time.

System 6 (2-8 Units) Parallel Series Regeneration

All tanks in parallel supplying treated water. Only #1 control will monitor flow meter/sensor input. When a regeneration is required for the system, it will regenerate valve address #1 first, immediately followed by #2, then #3, then #4 if installed. No more than one unit will be in Regeneration at a time.

System 7 (2 Units) Alternating Immediate

One tank online supplying treated water, one tank in Standby. Only #1 control will monitor its flow meter/sensor input. Regeneration of a unit will begin after the other control has left Standby and returned to Service. When the Regeneration cycle is complete, the regenerated unit will enter Standby. Standby on each tank is controlled by the relay on the NXT2 circuit board.

System 8 (2 Units) Alternating Delayed

Immediate Transfer Delayed Regeneration One tank online supplying treated water, one tank in Standby. Only #1 control will monitor its flow meter/sensor input. Online unit depletes its volume. Once this occurs the offline unit comes online. The previously online unit goes offline and delays its regeneration until the programmed regeneration time has been reached.

System 9 (2-8 Units) Alternating with Standby Units

Up to 7 tanks online supplying treated water, one tank in Standby. Meter/sensor input is required on each tank. Regeneration of a unit will begin after the other control has left Standby and returned to Service. When the Regeneration cycle is complete, the regenerated unit will enter Standby. Standby on each tank is controlled by the relay on the NXT2 circuit board.

System 14 (2-8 Units) Progressive Demand Recall

Meter input is required on each tank. Unit #1 will begin In Service with #2, #3, and #4 (if installed) will begin in Standby. At least one unit is In Service at all times. When flow rate to the Primary Service Unit increases to a user specified rate, the next unit in sequence will move from Standby to Service. As the flow rate falls below the user specified rate, subsequent tanks will return to Standby. When the Primary Service Unit regenerates, the next unit in sequence will become the new Primary Service Unit. As each units capacity is reached, the controller will initiate a Regeneration of that unit. Depending on the number of units in the system and flow rate demand, the regenerated unit will then be placed either into Standby or Service. Only one unit will be in Regeneration at a time.

NXT2 Master Programming Mode Flow Chart

CAUTION

Before entering Master Programming, please contact your local professional water dealer.

NOTICE

To identify your model softener, locate the diameter and height dimensions from the mineral tank label and check the specification charts within this manual to identify which model uses that size mineral tank and confirm controller type is correct.

NOTE: Depending on current option settings, some values cannot be viewed or set.

Master Programming Mode

1. Press and hold the Left and Down buttons simultaneously for 3 seconds to enter Master Programming mode.
2. To navigate, press the Extra Cycle button to advance to the next value. Press the Left button to retreat to the previous value.
3. Where applicable, use the Down and Up buttons to adjust a value as desired. When entering data into text fields (such as Assistance Name) or numerical fields (such as Hardness), press the Extra Cycle button to advance to the next character/digit and press the Left button to retreat to the previous character/digit. Proceed through all available characters/digits to advance to the next value.
4. To reset/clear a value (such as Assistance Name), while on the value, press and hold the Down and Up buttons simultaneously for 5 seconds.
5. To exit Master Programming Mode, progress through all available values or after 5 minutes of inactivity the controller will exit automatically. To exit master programming without saving changes, press the Left button until you return to the service screen.
6. Depending on the current controller programming, certain values may not be able to be viewed or set.
7. The controller will display local information, not system information.
8. In the event of a regeneration occurring while displaying master programming, the regeneration step and time remaining will be displayed. When regeneration has been completed, the display will return to the main screen.

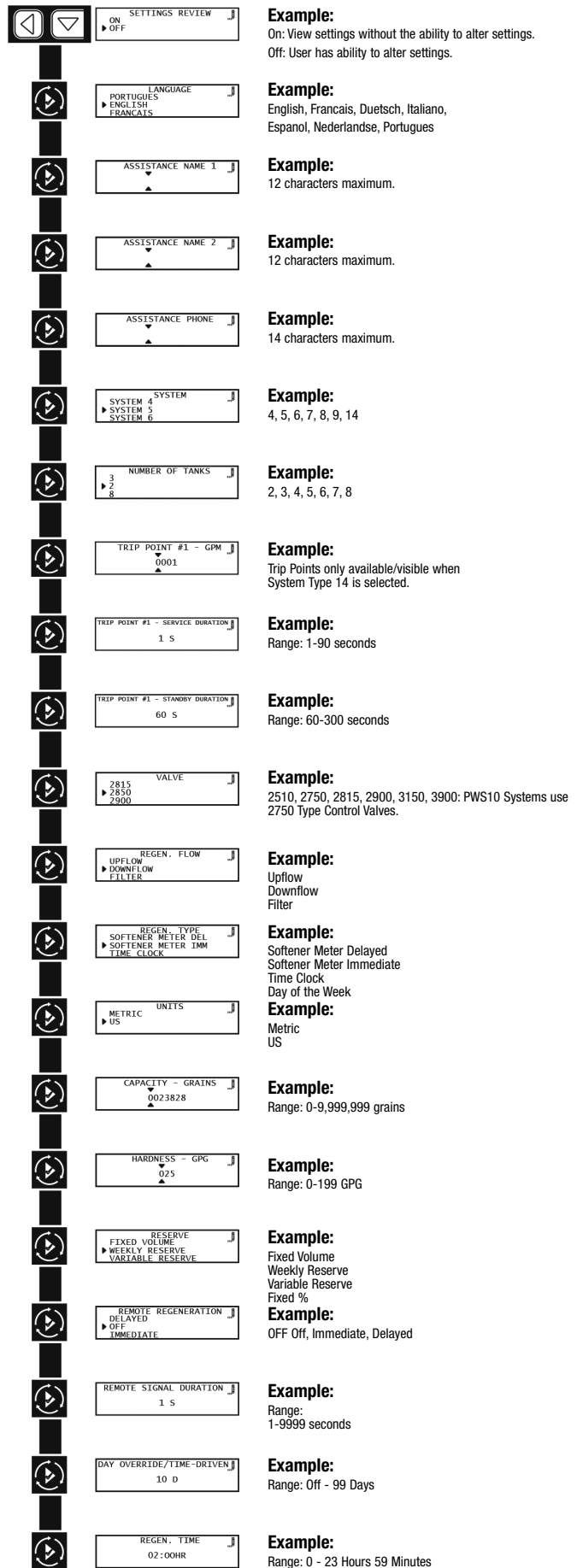

NXT2 Master Programming Mode Flow Chart - Cont'd

Example:

Range: 0 - 23 Hours 59 Minutes

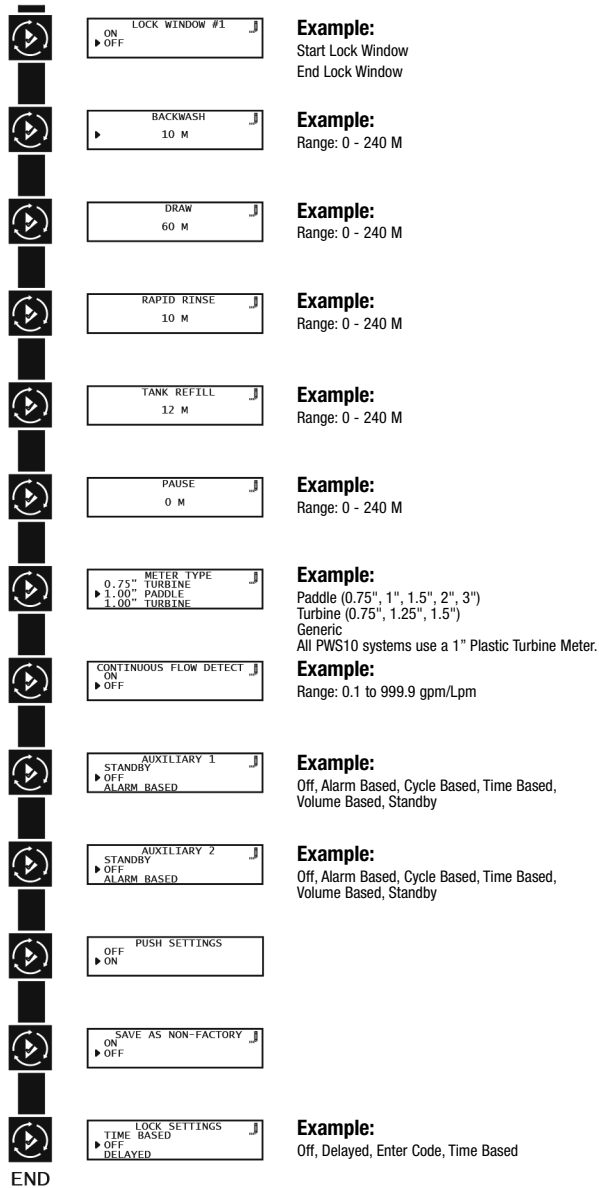

User Programming Mode Flow Chart

User Programming Mode

1. Press and hold the Down and Up buttons simultaneously for 3 seconds to enter the User Programming mode.
2. To navigate the menu, press the Extra Cycle button to advance to the next value. Press the Left button to retreat to the previous value.
3. Where applicable, use the Up and Down buttons to adjust a value as desired.
4. After progressing through all available values, the controller will return to Normal operation.
5. To exit diagnostic mode, progress through all cycles, or press & hold Left button at any time, or simply wait 5 minutes and controller will automatically return to normal operation.
- 6 Depending on the current controller settings, certain values may not be able to be viewed or set.
7. The controller will display local information, not system information.
8. In the event of a regeneration occurring while displaying user programming, the regeneration step and time remaining will be displayed. When regeneration has been completed, the display will return to the main screen.

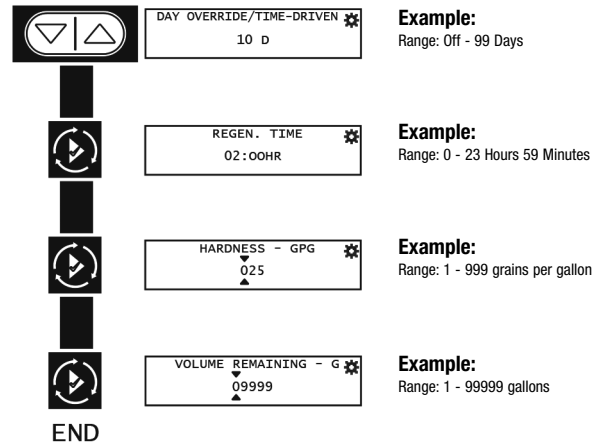

NXT2 Diagnostic Programming Mode Flow Chart

Diagnostic Programming Mode

1. Press and hold the Left button to enter Diagnostic Programming mode.
2. To navigate, press the Extra Cycle button to advance to the next value. Press the Left button to retreat to the previous value.
3. Where applicable, use the Up and Down buttons to adjust a value as desired.
4. To reset/clear a value (such as Totalizer or Error Log), while on the value, press and hold the Up and Down buttons simultaneously.
5. After progressing through all available values, the controller will return to normal operation.
6. To exit diagnostic mode, press and hold the Left button at anytime or after 5 minutes of inactivity the controller will return to normal operation automatically.
7. Depending on the current controller programming, certain values may not be able to be viewed or modified.
8. The controller will display local information, not system information.
9. In the event of a regeneration occurring while displaying diagnostics, the regeneration step and time remaining will be displayed. When regeneration has been completed, the display will return to the main screen.

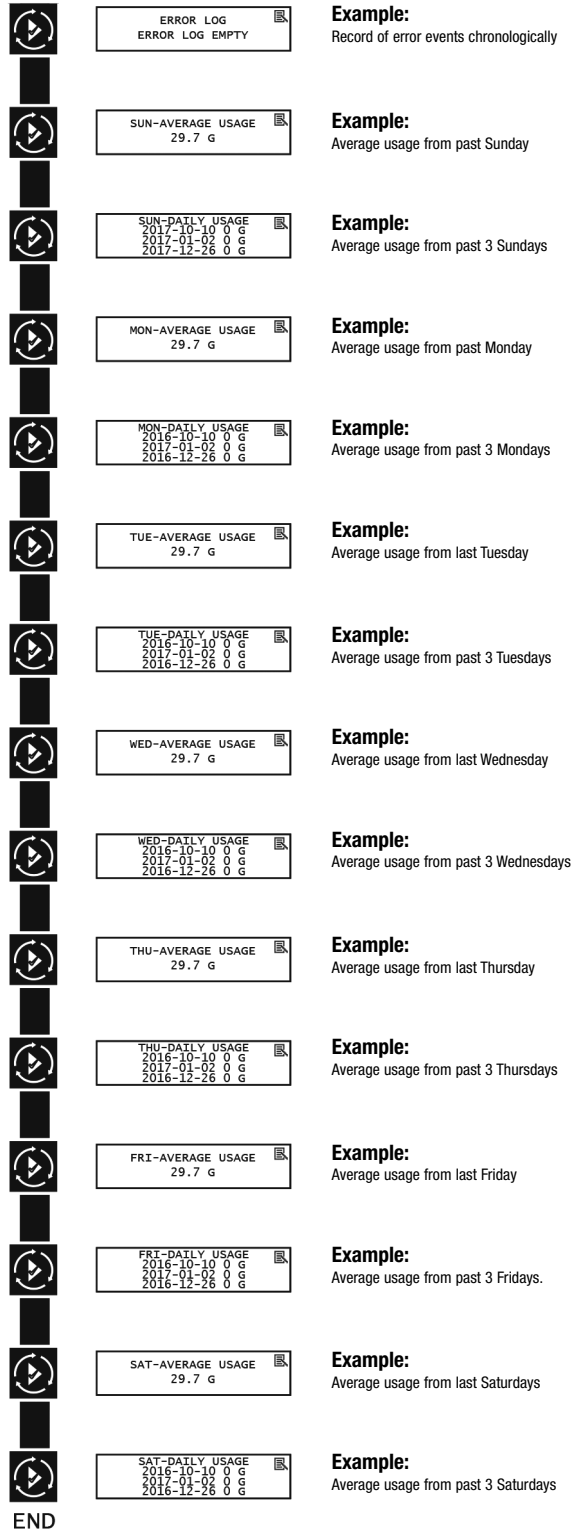
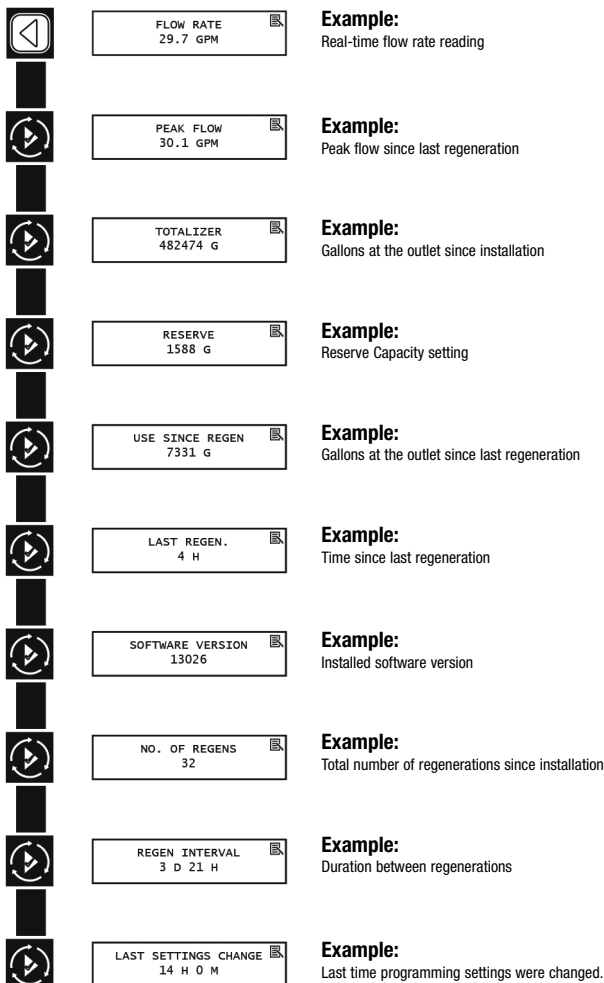

END

NXT2 Time of Day Programming Mode Flow Chart

Setting the Time of Day

NOTE: Set Time of Day on any unit and the rest of the units in the system will update the Time of Day automatically.

1. Press and hold the Up button for 2 seconds. The “Time” value is displayed. Press the Up or Down buttons to adjust as desired.
2. Press the Extra Cycle button to advance to the “Year” field. Press the Up or Down buttons to adjust as desired.
3. Press the Extra Cycle button to advance to the “Month” field. Press the Up or Down buttons to adjust as desired.
4. Press the Extra Cycle button to advance to the “Calendar Day” field. Press the Up or Down buttons to adjust as desired.
5. Press the Extra Cycle button to return to the normal display screen.

NOTE: Press and hold the Left button to exit without saving.

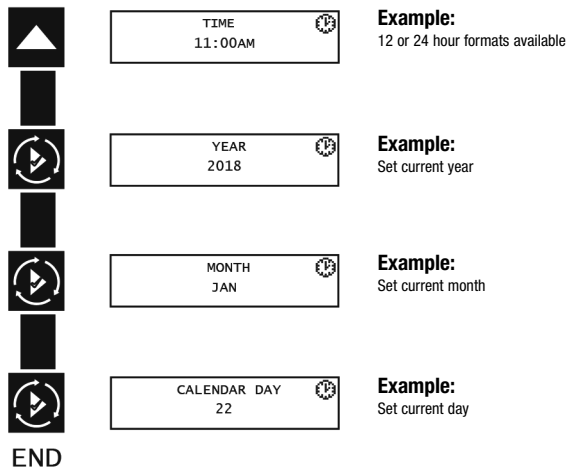

NXT2 Programming Parameters and Ranges

SYSTEM TYPE	4				5	6	7	8	9	14	PROGRAMMING PARAMETER RANGES	
REGEN TYPE	TIME CLOCK	DAY OF THE WEEK	SOFTENER/FILTER METERED IMMEDIATE	SOFTENER/FILTER METERED DELAYED	INTERLOCK	SERIES	ALTERNATING	ALTERNATING	ALTERNATING	PROGRESSIVE DEMAND RECALL	US	METRIC
Settings Review	X	X	X	X	X	X	X	X	X	X		On, Off
Language	X	X	X	X	X	X	X	X	X	X		English Francais Deutsch Italiano Espanol Nederlands Portugues
Assistance Name 1, 2	X	X	X	X	X	X	X	X	X	X		Custom
Assistance Phone	X	X	X	X	X	X	X	X	X	X		Custom
Regen Type	X	X	X	X	X	X	X	X	X	X		Time Clock Day of the Week Softener/Filter Metered Immediate Softener/Filter Metered Delayed
Valve	X	X	X	X	X	X	X	X	X	X		2510 2750 2815 2850 2900 3150 3900
Regen Flow	X	X	X	X	X	X	X	X	X	X		Upflow, Downflow, Filter
Units	X	X	X	X	X	X	X	X	X	X		US, Metric
Remote Regeneration	X	X	X	X	X	X	X	X	X	X		Off, Immediate, Delayed
Auxiliary 1, 2	X	X	X	X	X	X	X	X	X	X		Off, Alarm Based, Cycle Based, Time Based,
Lock Window 1, 2	X	X	X	X	X	X	X	X	X	X		On, Off
Meter Type			X	X	X	X	X	X	X	X		Paddle (0.75", 1", 1.5", 2", 3") Turbine (0.75", 1.25", 1.5") Generic
Continuous Flow Detect			X	X	X	X	X	X	X	X		On, Off
Save as Non Factory	X	X	X	X	X	X	X	X	X	X		On, Off
Lock Settings	X	X	X	X	X	X	X	X	X	X		Off, Delayed, Enter Code, Time Based
Day Override / Time Drive	X		X	X	X	X	X	X	X	X		Off-99 Days
Regen Time	X	X		X		X		X				Any
Day of the Week		X				X						SU, MO, TU, WE, TH, FR, SA
Capacity			X	X	X	X	X	X	X	X	0-9,999,999 Grains	0-9,999,999 Grams, 0-560,287 Lx°DH, 0-1,000,000 Lx°FTH, 0-701,557 Lx°EH
Hardness			X	X	X	X	X	X	X	X	0-199 GPG	0-19,999 mg/L, 0-1,402 °EH, 0-199.9 °FTH, 0-112 °DH
International Hardness Units			X	X	X	X	X	X	X	X		mg/L, °EH, °FTH, °DH
Reserve				X		X						Weekly Reserve, Variable Reserve, Fixed %, Fixed Volume
Number of Tanks (Max)	1	1	1	1	8	8	2	2	8	8		2, 3, 4, 5, 6, 7, 8
Push Settings					X	X	X	X	X	X		On, Off
Trip Point #1-7 GPM										X	0-1,999 GPM	0-7,569 LPM
Trip Point #1-7 SD										X		1-90s
Trip Point #1-7 STBD										X		60-300s

SXT Controller Programming and Operation



Controller Display

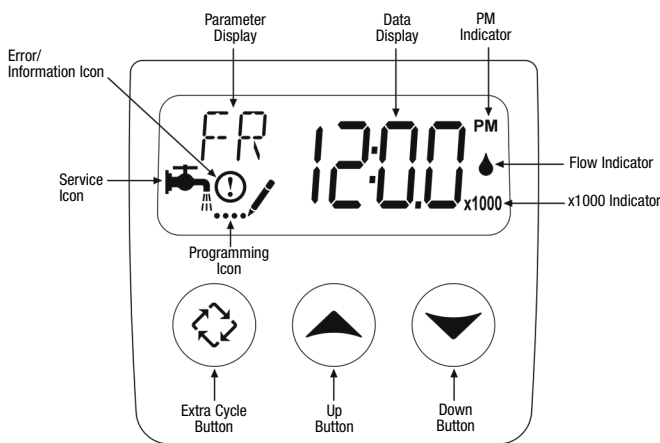

Figure 1

42637 Rev D

Features of the SXT:

- Power backup that continues to keep time and the passage of days for a minimum of 48 hours in the event of power failure. During a power outage, the control goes into a power-saving mode. It does not monitor water usage during a power failure, but it does store the volume remaining at the time of power failure.
- Settings for both valve (basic system) and control type (method used to trigger a regeneration).
- Day-of-the-Week controls.
- While in service, the display alternates between time of day, volume remaining or days to regeneration, and tank in service (twin tank systems only).
- The Flow Indicator flashes when outlet flow is detected.
- The Service Icon flashes if a regeneration cycle has been queued.
- A Regeneration can be triggered immediately by pressing the Extra Cycle button for five seconds.
- The Parameter Display displays the current Cycle Step (BW, BF, RR, etc) during regeneration, and the data display counts down the time remaining for that cycle step. While the valve is transferring to a new cycle step, the display will flash. The parameter display will identify the destination cycle step (BW, BF, RR, etc) and the data display will read "----". Once the valve reaches the cycle step, the display will stop flashing and the data display will change to the time remaining. During regeneration, the user can force the control to advance to the next cycle step immediately by pressing the extra cycle button.

Setting the Time of Day

1. Press and hold either the Up or Down buttons until the programming icon replaces the service icon and the parameter display reads TD.
2. Adjust the displayed time with the Up and Down buttons.
3. When the desired time is set, press the Extra Cycle button to resume normal operation. The unit will also return to normal operation after 5 seconds if no buttons are pressed.



Manually Initiating a Regeneration

1. Press the Extra Cycle button. The service icon will flash to indicate that a regeneration is queued.
2. To cancel a queued regeneration, press the Extra Cycle button.

Regenerating Immediately

Press and hold the Extra Cycle button for five seconds.

SXT Controller Operation

Meter Immediate Control

A Meter Immediate control measures water usage and regenerates the system as soon as the calculated system capacity is depleted. The control calculates the system capacity by dividing the unit capacity (typically expressed in grains/unit volume) by the feedwater hardness and subtracting the reserve. Meter Immediate systems generally do not use a reserve volume. However, in twin tank systems with soft-water regeneration, the reserve capacity should be set to the volume of water used during regeneration to prevent hard water break-through. A Meter Immediate control will also start a regeneration cycle at the programmed regeneration time if a number of days equal to the regeneration day override pass before water usage depletes the calculated system capacity.

Meter Delayed Control

A Meter Delayed Control measures water usage and regenerates the system at the programmed regeneration time after the calculated system capacity is depleted. As with Meter Immediate systems, the control calculates the system capacity by dividing the unit capacity by the feedwater hardness and subtracting the reserve. The reserve should be set to insure that the system delivers treated water between the time the system capacity is depleted and the actual regeneration time. A Meter Delayed control will also start a regeneration cycle at the programmed regeneration time if a number of days equal to the regeneration day override pass before water usage depletes the calculated system capacity.

Time Clock Delayed Control

A Time Clock Delayed Control regenerates the system on a timed interval. The control will initiate a regeneration cycle at the programmed regeneration time when the number of days since the last regeneration equals the regeneration day override value.

Day of the Week Control

This control regenerates the system on a weekly schedule. The schedule is defined in Master Programming by setting each day to either "off" or "on." The control will initiate a regeneration cycle on days that have been set to "on" at the specified regeneration time.

Control Operation During Regeneration

During regeneration, the control displays a special regeneration display. In this display, the control shows the current regeneration step number the valve is advancing to, or has reached, and the time remaining in that step. The step number that displays flashes until the valve completes driving to this regeneration step position. Once all regeneration steps are complete the valve returns to service and resumes normal operation.

Pressing the Extra Cycle button during a regeneration cycle immediately advances the valve to the next cycle step position and resumes normal step timing.

Control Operation During Programming

The control only enters the Program Mode with the valve in service. While in the Program Mode, the control continues to operate normally monitoring water usage and keeping all displays up to date. Control programming is stored in memory permanently, eliminating the need for battery backup power.

Manually Initiating a Regeneration

To occur that day at the next scheduled regeneration time:

1. Press the Extra Cycle button. The service icon will flash to indicate that a regeneration is queued.
2. To cancel a queued regeneration, press the Extra Cycle button.

To occur immediately:

1. When controller is in service, press the Extra Cycle button for 5 seconds on the main screen.
2. The controller advances to Regeneration Cycle Step #1 (Backwash), and begins programmed time count down.
3. Press the Extra Cycle button once to advance valve to Regeneration Cycle Step #2 (Brine Draw/Rinse).
4. Press the Extra Cycle button once to advance valve to Regeneration Cycle Step #3 (Rapid rinse).
5. Press the Extra Cycle button once to advance valve to Regeneration Cycle Step #4 (Brine Refill).
6. Press the Extra Cycle button once more to advance the valve back to in service.

NOTE: If the unit is a filter or upflow, the cycle step order may change.

NOTE: If regeneration occurs for any reason prior to the delayed regeneration time, the manual regeneration request shall be cleared.

Control Operation During A Power Failure

The SXT includes integral power backup. In the event of power failure, the control shifts into a power-saving mode. The control stops monitoring water usage, and the display and motor shut down, but it continues to keep track of the time and day for a minimum of 48 hours.

The system configuration settings are stored in a non-volatile memory and are stored indefinitely with or without line power. The Time of Day flashes when there has been a power failure. Press any button to stop the Time of Day from flashing.

If power fails while the unit is in regeneration, the control will save the current valve position before it shuts down. When power is restored, the control will resume the regeneration cycle from the point where power failed. Note that if power fails during a regeneration cycle, the valve will remain in its current position until power is restored. The valve system should include all required safety components to prevent overflows resulting from a power failure during regeneration.

The control will not start a new regeneration cycle without line power. If the valve misses a scheduled regeneration due to a power failure, it will queue a regeneration. Once power is restored, the control will initiate a regeneration cycle the next time that the Time of Day equals the programmed regeneration time. Typically, this means that the valve will regenerate one day after it was originally scheduled. If the treated water output is important and power interruptions are expected, the system should be setup with a sufficient reserve capacity to compensate for regeneration delays.

SXT Master Programming Mode Chart

⚠ CAUTION

Before entering Master Programming, please contact your local professional water dealer. To enter Master Programming, set time to 12:01 PM.

MASTER PROGRAMMING OPTIONS			
Abbreviation	Parameter	Option Abbreviation	Options
DF	Display Format	GAL	Gallons
		Ltr	Liters
VT	Valve Type	dF1b	Downflow/Upflow Single Backwash
		dF2b	Downflow Double Backwash
		Ftr	Filter
		Ufbd	Upflow Brine First
		Uftr	Upflow Filter
		Othr	Other
CT	Control Type	Fd	Meter (Flow) Delayed
		Fl	Meter (Flow) Immediate
		tc	Time Clock
		dAY	Day of Week
NT	Number of Tanks	1	Single Tank System
		2	Two Tank System
TS	Tank in Service	U1	Tank 1 in Service
		U2	Tank 2 in Service
C	Unit Capacity		Unit Capacity (Grains)
H	Feedwater Hardness		Hardness of Inlet Water
RS	Reserve Selection	SF	Percentage Safety Factor
		rc	Fixed Reserve Capacity
SF	Safety Factor		Percentage of the system capacity to be used as a reserve
RC	Fixed Reserve Capacity		Fixed volume to be used as a reserve
DO	Day Override		The system's day override setting
RT	Regen Time		The time of day the system will regenerate
BW, BD, RR, BF	Regen Cycle Step Times		The time duration for each regeneration step. Adjustable from OFF and 0-199 minutes. NOTE: If "Othr" is chosen under "Valve Type", then R1, R2, R3, etc, will be displayed instead
D1, D2, D3, D4, D5, D6, & D7	Day of Week Settings		Regeneration setting (On or OFF) for each day of the week on day-of-week systems
CD	Current Day		The current day of the week
FM	Flow Meter Type: All PWS10 systems use a 1" Plastic Turbine Meter.	P0.7	¾" Paddle Wheel Meter
		Gen	Generic or Other Meter
		P2.0	2" Paddle Wheel Meter
		t1.5	1.5" Turbine Meter
		P1.5	1.5" Paddle Wheel Meter
		t1.2	1.25" Turbine Wheel Meter
		t1.0	1" Turbine Meter
		P1.0	1" Paddle Wheel Meter
K	Meter Pulse Setting	t0.7	¾" Turbine Meter
			Meter pulses per gallon for generic/other flow meter

NOTE: Some items may not be shown depending on controller configuration. The controller will discard any changes and exit Master Programming Mode if any button is not pressed for sixty seconds.

SXT Master Programming Mode

When Master Programming Mode is entered, all available option setting displays may be viewed and set as needed. Depending on current option settings, some parameters cannot be viewed or set.

Setting the Time of Day

1. Press and hold either the Up or Down buttons until the programming icon replaces the service icon and the parameter display reads TD.
2. Adjust the displayed time with the Up and Down buttons.
3. When the desired time is set, press the Extra Cycle button to resume normal operation. The unit will also return to normal operation after five seconds if no buttons are pressed.



Figure 2

Entering Master Programming Mode

Set the Time of Day display to 12:01 P. M. Press the Extra Cycle button (to exit Setting Time of Day mode). Then press and hold the Up and Down buttons together until the programming icon replaces the service icon and the display format screen appears.

Exiting Master Programming Mode

Press the Extra Cycle button to accept the displayed settings and cycle to the next parameter. Press the Extra Cycle button at the last parameter to save all settings and return to normal operation. The control will automatically disregard any programming changes and return to normal operation if it is left in Master Programming mode for 5 minutes without any keypad input.

Resets

Soft Reset

Press and hold the Extra Cycle and Down buttons for 25 seconds while in normal Service mode. This resets all parameters to the system default values. Not reset are the volume remaining in meter immediate or meter delayed systems and days since regeneration in the time clock system.

Master Reset

Hold the Extra Cycle button while powering up the unit. This resets all of the parameters in the unit. Check and verify the choices selected in Master Programming Mode.

1. Display Format (Display Code DF)

This is the first screen that appears when entering Master Programming Mode. The Display Format setting specifies the unit of measure that will be used for volume and how the control will display the Time of Day. This option setting is identified by "DF" in the upper left corner of the screen. There are two possible settings.

Display Format Setting	Display Format Setting	Time Display
GAL	U.S. Gallons	12-Hour AM/PM
Ltr	Liters	24-Hour



Figure 3

2. Valve Type (Display Code VT)

Press the Extra Cycle button. Use the display to set the Valve Type.

3. Regenerant Flow (Display Code RF)

Press the Extra Cycle button. The Regenerant Flow Setting specifies the type of cycle that the valve follows during regeneration. Note that some valve configurations are built with specific subcomponents. Ensure the valve is configured properly before changing the Regenerant Flow setting. This option setting is identified by "RF" in the upper left corner of the screen. There are eight possible settings.

Abbreviation	Parameter
dF1b	Standard Downflow Single Backwash
dF2b	Standard Downflow Double Backwash
Fltr	Filter
dFFF	Downflow Fill First
UFbd	Upflow Brine First
UFFF	Upflow Fill First
UFIt	Upflow Filter
O-dF	Other Downflow
O-UF	Other Upflow

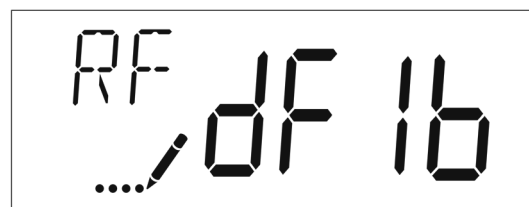

Figure 4

4. Control Type (Display Code CT)

Press the Extra Cycle button. Use this display to set the Control Type. This specifies how the control determines when to trigger a regeneration. For details on how the various options function, refer to the Control Operation section of this service manual. This option setting is identified by "CT" in the upper left corner of the screen. There are four possible settings.

SXT Master Programming Mode - Cont'd

Abbreviation	Parameter
Fd	Meter (Flow) Delayed
FI	Meter (Flow) Immediate
tc	Time Clock
dAY	Day of Week

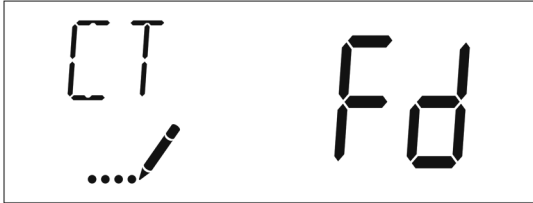

Figure 5

5. Unit Capacity (Display Code C)

Press the Extra Cycle button. Use this display to set the Unit Capacity. This setting specifies the treatment capacity of the system media. Enter the capacity of the media bed in grains of hardness when configuring a softener system, or desired volume capacity when configuring a filter system. This option setting is identified by "C" in the upper left corner of the screen (or by "V" if volume capacity for a filter). The Unit Capacity parameter is only available if the control type has been set to one of the metered options. Use the Up and Down buttons to adjust the value as needed.



Figure 6

Range: 1-999.9 x 1000 grains/gallon (mg/liter)

6. Feed Water Hardness (Display Code H)

Press the Extra Cycle button. Use this display to set the Feed Water Hardness. Enter the feed water hardness in grains per gallon or degrees for softener systems. This option setting is identified by "H" in the upper left corner of the screen. The feed water hardness parameter is only available if the control type has been set to one of the metered softener options. Use the Up and Down buttons to adjust the value as needed.



Figure 7

Range: 1-199 grains (degrees)

7. Reserve Selection (Display Code RS)

Press the Extra Cycle button. Use this display to set the Safety Factor and to select the type of reserve to be used in your system. This setting is identified by "RS" in the upper left corner of the screen. The reserve selection parameter is only available if the control type has been set to one of the metered options. There are three possible settings.

Abbreviation	Parameter
SF	Safety Factor
rc	Fixed Reserve Capacity
cr	Variable Reserve

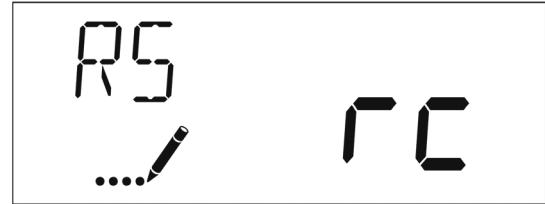

Figure 8

8. Safety Factor (Display Code SF)

Press the Extra Cycle button. Use this display to set the Safety Factor. This setting specifies what percentage of the system capacity will be held as a reserve. Since this value is expressed as a percentage, any change to the unit capacity or feed water hardness that changes the calculated system capacity will result in a corresponding change to the reserve volume. This option setting is identified by "SF" in the upper left corner of the screen. Use the UP and Down buttons to adjust the value from 0 to 50% as needed.

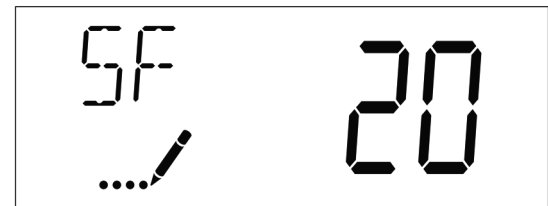

Figure 9

Range: 0-50%

9. Fixed Reserve Capacity (Display Code RC)

Press the Extra Cycle button. Use this display to set the Reserve Capacity. This setting specifies a fixed volume that will be held as a reserve. The Reserve Capacity cannot be set to a value greater than one-half of the calculated system capacity. The Reserve Capacity is a fixed volume and does not change if the unit capacity or feed water hardness are changed. This option setting is identified by "RC" in the upper left corner of the screen. Use the Up and Down buttons to adjust the value as needed.

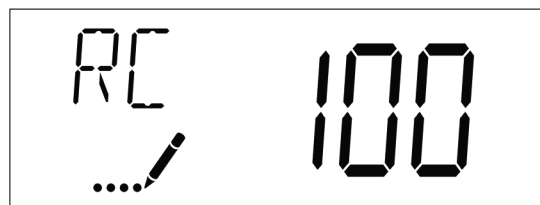

Figure 10

Range: 0-half of the calculated system capacity

SXT Master Programming Mode - Cont'd

10. Variable Reserve (Display Code CR)

Press the Extra Cycle button. Use this display to set the Variable Reserve. This setting is formulated to adjust the reserve dependant on the previous calendar day's water usage. During each regeneration, the reserve will change based on the old reserve capacity and the previous day's water usage. This option setting is identified by "CR" in the upper left corner of the screen.

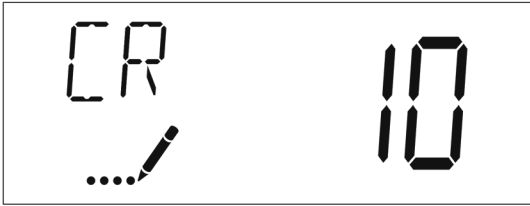

Figure 11

11. Day Override (Display Code DO)

Press the Extra Cycle button. Use this display to set the Day Override. This setting specifies the maximum number of days between regeneration cycles. If the system is set to a timertype control, the day override setting determines how often the system will regenerate. A metered system will regenerate regardless of usage if the days since last regeneration cycle equal the day override setting. Setting the day override value to "OFF" disables this function. This option setting is identified by "DO" in the upper left corner of the screen. Use the Up and Down buttons to adjust the value as needed.



Figure 12

Range: Off-99 days

12. Regeneration Time

Press the Extra Cycle button. Use this display to set the Regeneration Time. This setting specifies the time of day the control will initiate a delayed, manually queued, or day override regeneration. This option setting is identified by "RT" in the upper left corner of the screen. Use the Up and Down buttons to adjust the value as needed.

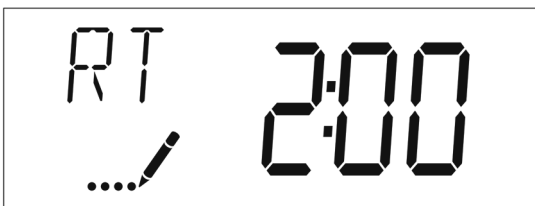

Figure 13

13. Regeneration Cycle Step Times

Press the Extra Cycle button. Use this display to set the Regeneration Cycle Step Times. The different regeneration cycles are listed in sequence based on the valve type selected for the system, and are identified by an abbreviation in the upper left corner of the screen. The abbreviations used are listed below.

Abbreviation	Cycle Step
BD	Brine Draw
BF	Brine Fill
AD	Air Draw
BW	Backwash
RR	Rapid Rinse
SV	Service

If the system has been configured with the "Other" valve type, the regeneration cycles will be identified as C1, C2, ..., C20. Cycle steps can be programmed in any order using the Up or Down buttons with the following selections. Up to 20 individual cycles can be set. Time for each cycle can be set from 0 to 199 minutes. Setting a cycle step time to 0 will cause the control to skip that step during regeneration, but keeps the following steps available. Use the Up and Down buttons to adjust the value as needed. Press the Extra Cycle button to accept the current setting and move to the next parameter. Program the last cycle step as LC which forces the valve back to the service position.

Abbreviation	Cycle Step
RR	Rapid Rinse
BD	Brine Draw
SR	Slow Rinse
BW	Backwash
RF	Refill
SP	Service Position
LC	Last Cycle



Figure 14

Range: 0-199 minutes

14. Day of Week Settings

Press the Extra Cycle button. Use this display to set the regeneration schedule for a system configured as Day of Week control. The different days of the week are identified as D1, D2, D3, D4, D5, D6, and D7 in the upper left corner of the display. Set the value to "ON" to schedule a regeneration or "OFF" to skip regeneration for each day. Use the Up and Down buttons to adjust the setting as needed. Press the Extra Cycle button to accept the setting and move to the next day. Note that the control requires at least one day to be set to "ON" if all 7 days are set to "Off", the unit will return to Day 1 until one or more days are set to "ON".



Figure 15

SXT Master Programming Mode - Cont'd

15. Current Day (Display Code CD)

Press the Extra Cycle button. Use this display to set the current day on systems that have been configured as Day of Week controls. This setting is identified by "CD" in the upper left corner of the screen. Use the Up and Down buttons to select from Day 1 through Day 7.

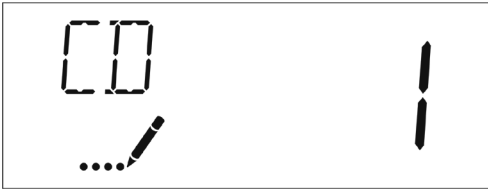

Figure 16

16. Flow Meter Type (Display Code FM)

Press the Extra Cycle button. Use this display to set the type of flow meter connected to the control. This option setting is identified by "FM" in the upper left corner of the screen. Use the Up and Down buttons to select one of the eight available settings. All PWS10 systems use a 1" Plastic Turbine Meter.

Abbreviation	Description
P0.7	¾" Paddle Wheel Meter
t0.7	¾" Turbine Meter
P1.0	1" Paddle Wheel Meter
t1.0	1" Turbine Meter
P1.5	1.5" Paddle Wheel Meter
t1.5	1.5" Turbine Meter
P2.0	2" Paddle Wheel Meter
Gen	Generic or Other non-Fleck Meter
t1.2	1.25" Turbine Meter



Figure 17

17. Meter Pulse Setting (Display Code K)

Press the Extra Cycle button. Use this display to specify the meter pulse setting for a non-standard flow meter. This option setting is identified by "K" in the upper left corner of the screen. Use the Up and Down buttons to enter the meter constant in pulses per unit volume.



Figure 18

K Range: 0.1 to 999.9 pulses per gallon.

18. Relay Setting (Display Code RE)

Press the Extra Cycle button. Use this display to enable the relay output. This option setting is identified by "RE" in the upper left corner of the screen. Use the Up and Down buttons to enable the relay using **either** time based (tb) or flow based (Fb). **Only one method can be used at a time.**

For time based, set the desired Start Time (ST) and End Time (ET). Time ranges available are determined by the Regen Cycle Step Times. For flow based, set the desired Volume Interval (VO) and Time On (TO).



Figure 19

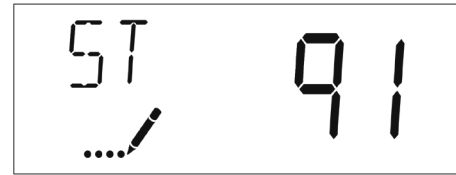

Figure 20

ST Range: 0 to total number of cycles minus 1



Figure 21

ET Range: Start time to total of all cycles

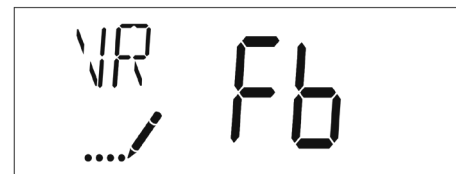

Figure 22



Figure 23

VO Range: 1 to Total Gallon Capacity



Figure 24

TO Range: 1 to 7200 (minutes)

19. End of Master Programming Mode

Press the Extra Cycle button to save all settings and exit Master Programming Mode.

Viewing Diagnostic Data

The SXT controller records and maintains diagnostic data to assist with servicing and troubleshooting the water treatment system.

Abbreviation	Parameter	Description
FR	Flow Rate	Displays the current outlet flow rate.
PF	Peak Flow Rate	Displays the highest flow rate measured since last regeneration.
HR	Hours in Service	Displays the total hours that the unit has been in service since last regeneration.
VU	Volume Used	Displays the total volume of water treated by the unit since last regeneration.
RC	Reserve Capacity	Displays the system's reserve capacity calculated from the system capacity, feed water hardness, and safety factor.
TV	Totalizer Volume	Displays the total volume of water used by the unit since last installation or last reset.
SV	Software Version	Displays the software version installed on the controller.

NOTE: Some items may not be shown depending on control configuration. The control will discard any changes and exit the Diagnostics View if a button is not pressed for 60 seconds.

Diagnostics View Steps

1. Press the Up and Extra Cycle buttons for five seconds while in service.
2. Use this display to view the current Flow Rate. This option setting is identified by "FR" in the upper left corner of the screen.



Figure 25

3. Press the Up button. Use this display to view the Peak Flow Rate since the last regeneration cycle. This option setting is identified by "PF" in the upper left corner of the screen.



Figure 26

4. Press the Up button. Use this display to view the Hours in Service since the last regeneration cycle. This option setting is identified by "HR" in the upper left corner of the screen.



Figure 27

SXT Diagnostics - Cont'd

5. Press the Up button. Use this display to view the Volume Used since the last regeneration cycle. This option setting is identified by "VU" in the upper left corner of the screen.

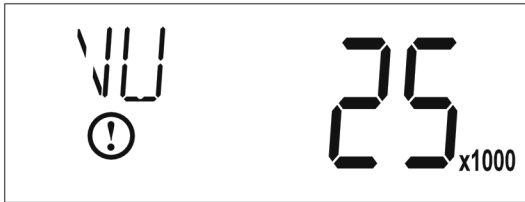

Figure 28

7. Press the Up button. Use this display to view the Total Volume data. This option is identified by "TV" in the upper left corner of the screen.



Figure 30

6. Press the Up button. Use this display to view the Reserve Capacity. This option setting is identified by "RC" in the upper left corner of the screen.



Figure 29

8. Press the Up button. Use this display to view the Software Version. This option setting is identified by "SV" in the upper left corner of the screen.

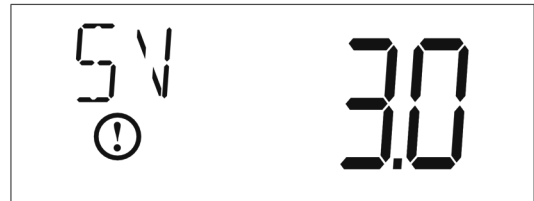

Figure 31

9. Press the Extra Cycle button to end Diagnostic Programming Mode.

Replacing the Media

NOTICE

Ion exchange resin may need to be replaced periodically due to physical breakdown caused by chlorine/chloramine disinfectants, or fouling caused by certain metals such as iron and manganese.

1. Mark the location of the mineral tanks on the floor incase they need to be moved once all water, resin and gravel has been removed. This will help with realignment of the plumbing after media replacement. DO NOT attempt to move a mineral tank that contains media and or water.
 2. Open the bypass valve.
 3. Close the inlet and outlet isolation valves for the mineral tank needing media replacement
 4. Locate "Manually Initiating a Regeneration" on page 17 for NXT2 and page 26 for SXT controllers and follow the steps to place the system in the backwash position. This relieves any pressure inside the mineral tank. Once the system cycles into the backwash position, unplug the control valve from the power outlet to keep the system in the backwash position.
 5. Disconnect the inlet, outlet, and drain union plumbing fittings. Then, if necessary for the removal of the control valve from the mineral tank, remove the remaining plumbing from the inlet, outlet and drain ports of the control valve.
 6. Disconnect the meter cable from the from the meter dome and from the NXT2 P5 port or SXT P1 port located on the back of the control valve controller. Store the meter cable in a safe location.
 7. Disconnect the brine tubing from the control valve's brine connection port.
 8. Disconnect the power supply cable from NXT2 P14 port or SXT P2PWR port located on the back of the control valve controller.
 9. If this is an NXT2 multi-tank system that uses the communication cable ports, disconnect any interconnecting communication cables from the P1 and P3 ports located on the back of the control valve NXT2 controllers.
 10. Remove the control valve from the mineral tank by turning the control valve counter-clockwise when viewed from above. Keeping a firm grip on the control valve, continue to rotate until it can be lifted off of the top of the mineral tank. Store the control valve in a safe location.
 11. Note the top of the distributor tube. It must be flush with the top of the tank. If it is above the top of the tank by more than $\frac{1}{2}$ " the distributor tube may have become disconnected from the distributor screen in the bottom of the mineral and must be reconnected.
 12. Obtain a length of $\frac{3}{4}$ " sch. 40 PVC that is the same height as the mineral tank and a length of 1" clear braided poly-vinyl hose. The hose must be long enough to reach the nearest floor drain. (Both of these can be acquired at a local hardware store).
 13. Insert one end of the pipe inside the hose and the other end of the pipe into the top of the mineral tank and down into the resin media. Put the other end of the hose inside a water permeable bag and locate the bag over the floor drain.
 14. Insert a garden hose into the bag side of the poly-vinyl hose to fill the hose and PVC pipe with water. Air will bubble out of the tank. Once all the air is out of the hose and pipe, remove the garden hose from the polyvinyl hose to establish a siphon. The resin can then be siphoned into the bag. Use the garden hose to maintain a full water level in the mineral tank to. The bag end of the poly-vinyl hose must remain lower in elevation then the end of the PVC pipe in the mineral tank to maintain the siphon. The bag will retain the resin while the water flows down the drain. Use caution not to allow resin to enter the floor drain.
 15. Continue to siphon resin until it is completely evacuated from the mineral tank. Gravel will clogged the siphon hose and, if it must be removed due to fouling, or to repair or replace a damaged distributor tube and screen, must be evacuated by other means.
 16. If replacing gravel, inspect lower distributor screens for damage and replace if necessary.
 17. To add new media and reconnect control valve to mineral tank follow General Installation steps 3-4K located on page 9 of this manual.
 18. Reconnect inlet, outlet, and drain plumbing to the control valve and tighten the plumbing union fittings on each of these plumbing lines.
 19. Reconnect brine tubing to brine connection port of control valve.
 20. Reconnect meter cable to meter dome. Then reconnect the other end of the meter cable to the NXT2 P5 port or SXT P1 port located on the back of the control valve controller.
 21. If this is an NXT2 multi-tank system that uses the communication cable ports, reconnect any interconnecting communication cables to the P1 and P3 ports located on the back of the control valve NXT2 controllers.
 22. Open the inlet isolation valve slightly, until water can be heard flowing through the isolation valve and allow the mineral tank to fill with water. Air will come out of the drain line until the mineral tank is full of water. Once water flow at the drain line is observed, fully open the inlet valve and allow water flow to drain for 10 minutes to flush the resin bed of any color. If water at the drain shows any discoloration, continue to flush the resin bed until water at the drain is clear.
 23. After resin bed flushing is complete, reconnect the power supply cable to the NXT2 P14 port or SXT P2PWR port located on the back of the control valve controller. Plug the system back in to the power outlet so that it will return to the service position.
 24. Fully open inlet and outlet isolation valves and close bypass valve.
 25. Check for leaks and repair as required.
 26. Open hot and cold side of a treated water faucet to flush any air from the plumbing system.
- If this is a multi-tank system replace media in each mineral tank according to this media replacement procedure.

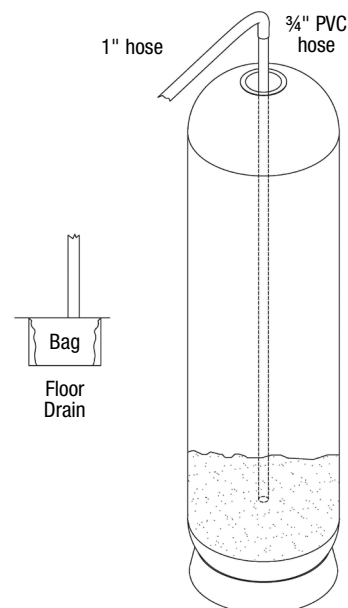

Replacement Parts - Major System Components

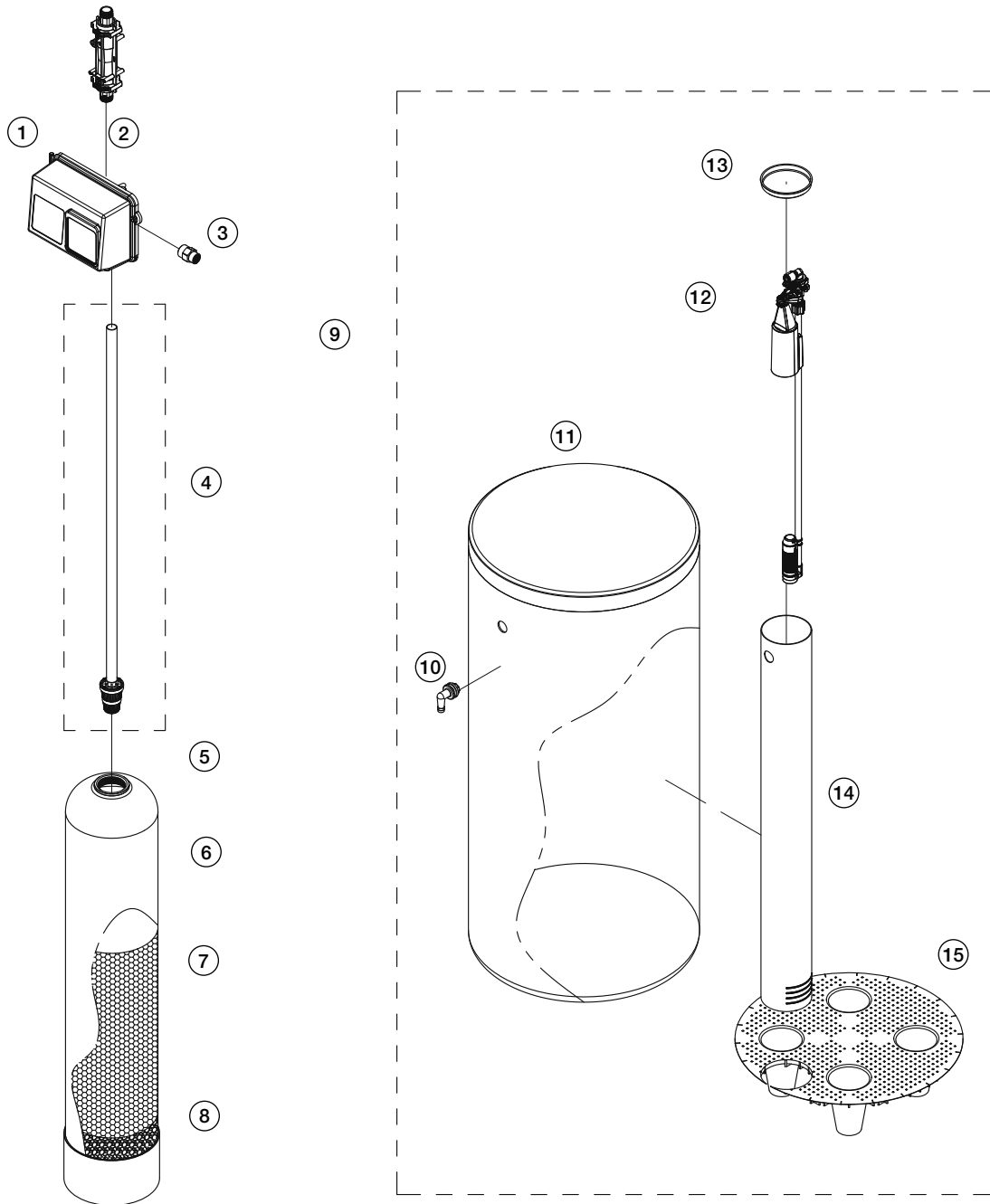

MAJOR SYSTEM COMPONENTS

ITEM NO.	QTY	ORDERING CODES	DESCRIPTION
1	1	68103898	K40275015-002 VALVE 2750/1650 NXT2 120V HWBP NO METER FOR SIMPLEX MODELS
1	1	68103792	K4010ESE VALVE 2750/1650 SXT 120V HWBP NO METER FOR SIMPLEX MODELS
2	1	68104397	K4519791-02 ELECTRONIC METER CABLE 35" (NOT SHOWN, SEE PAGE 37 FOR ADDITIONAL CABLES)
3	1	NA	DRAIN LINE FLOW CONTROLLER- SEE PAGE 41 FOR SELECTION
4	1	68101205	D5036 BELLED DIST TUBE ASSEMBLY FOR 9"-12" SOFTENERS
4	1	68101197	D5007 K4 DIST TUBE ASSEMBLY FOR 14"-16" SOFTENERS
5	1	68106674	Q9031 TANK ADAPT BUSHING 2.5" X 4"#8 THREAD PVC W/ORING FOR 14" & 16" SOFTENERS (NOT SHOWN)
6	1	68100914	C9084 FIBERGLASS MINERAL TANK 9X48 ALMOND W/ 2.5" #8 TOP
6	1	68100934	C9092 FIBERGLASS MINERAL TANK 10X54 ALMOND W/ 2.5" #8 TOP
6	1	68100967	C9094X FIBERGLASS MINERAL TANK 12X52 ALMOND W/ 2.5" #8 TOP

Continued on next page

Replacement Parts

Continued from previous page

MAJOR SYSTEM COMPONENTS			
ITEM NO.	QTY	ORDERING CODES	DESCRIPTION
6	1	68100997	C9098 FIBERGLASS MINERAL TANK 14X65 ALMOND W/ 4" #8 TOP
6	1	68101000	C9099-4 FIBERGLASS MINERAL TANK 16X65 ALMOND W/ 4" #8 TOP
7	*	68100326	A4000 SOFTENING RESIN MEDIA WATTS BRAND HIGH CAPACITY SAC NA FORM
8	*	68100354	A7005A MEDIA GRAVEL #20 FLINT .06"X.125"
9	1	68102491	G2002BS BRINE TANK ASSY 18X40 BLK W/ GRID, SAFETY FLOAT & AIR CHECK FOR 3/8" BRINE HOSE
10	1	68102593	H1018 BRINE OVERFLOW SET
11	1	68102491	G2002B BRINE TANK 18X40 BLK EMPTY
12	1	68102591	H1016 BRINE WELL CAP 4"
13	1	68102634	H7007 BRINE SAFETY FLOAT BRINE VALVE AND AIR CHECK ASSY 2310 FOR 3/8" BRINE HOSE
14	1	68102598	H1030-36S BRINE WELL 4"X36" SLOTTED
15	1	68102607	H1072 BRINE GRID FOR 18" DIAMETER BRINE TANKS

Replacement Parts - 2750 Powerhead

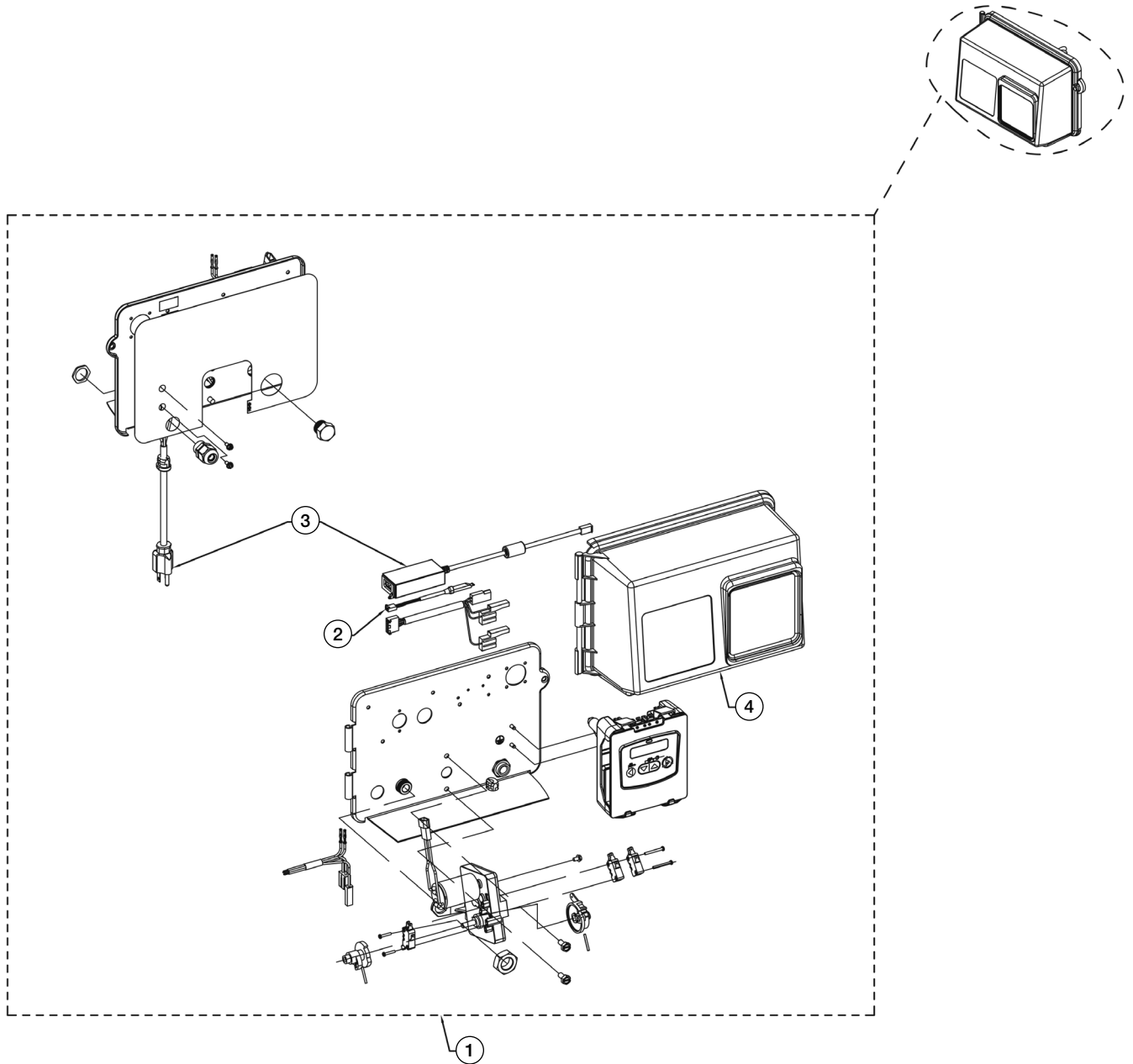

2750 POWERHEAD			
ITEM NO.	QTY	ORDERING CODE	DESCRIPTION
1	1	68109678	K4562103-08 POWERHEAD ASSEMBLY F/2750 24V FITS NXT2 OR SXT, NO TIMER OR COVER
2	1	68104396	K4519791-01 ELECTRONIC METER CABLE FOR ELECTRONIC METER 16.85" LONG
2	1	68104397	K4519791-02 ELECTRONIC METER CABLE FOR ELECTRONIC METER 35" LONG
2	1	68104398	K4519791-04-EVT ELECTRONIC METER CABLE FOR ELECTRONIC METER 100.00" LONG
2	1	68104399	K4519791-05 ELECTRONIC METER CABLE FOR ELECTRONIC METER 304.00" LONG
3	1	68104471	K4544164 POWER SUPPLY, INTL., 120V/24V/40VA
4	1	68104575	K4560219-02 ENVIRONMENTAL COVER F/ 2750

NXT2 Controller Assembly

1

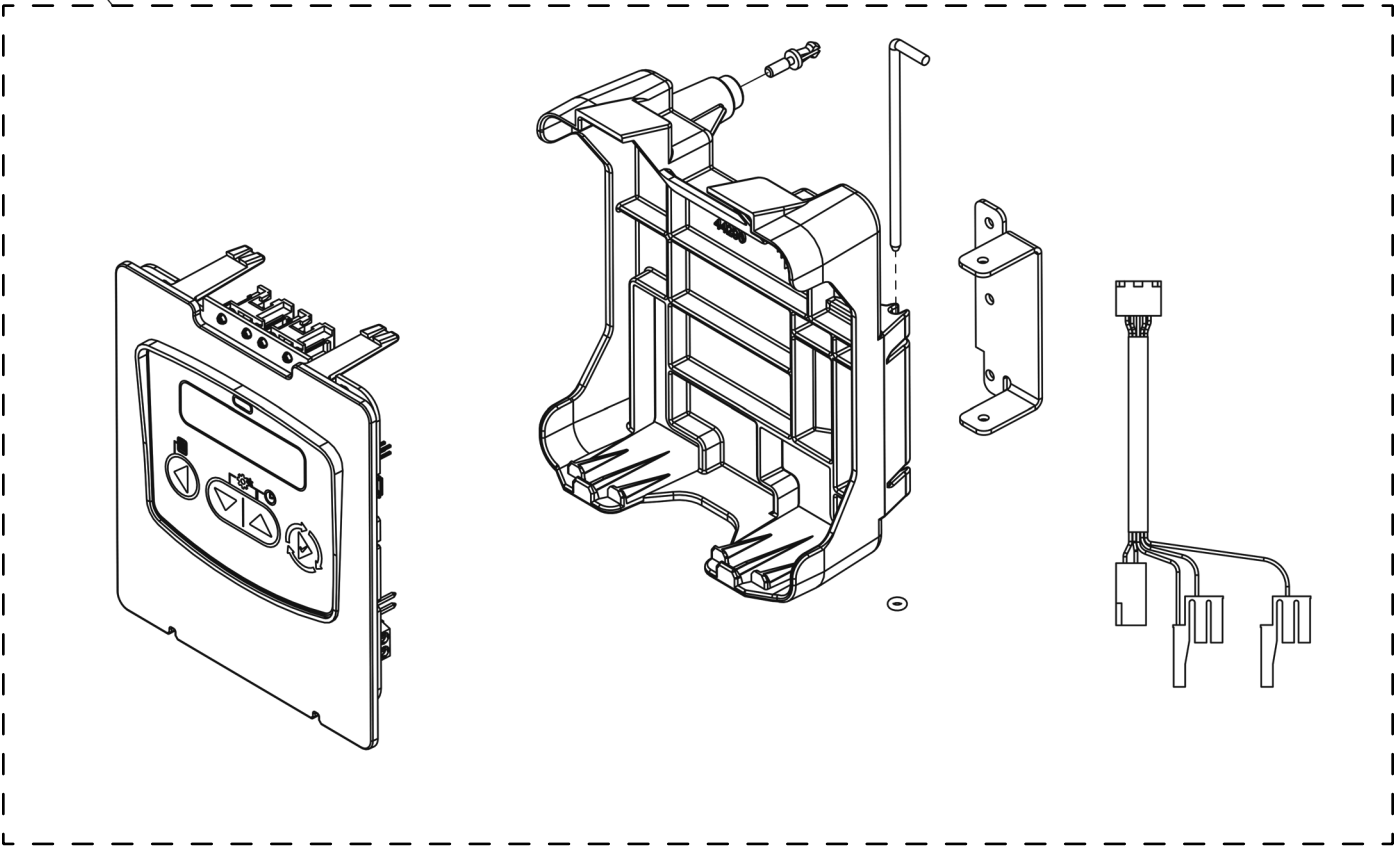

62115 Rev A

NXT2 CONTROLLER ASSEMBLY			
ITEM NO.	QTY	ORDERING CODE	DESCRIPTION
1	1	68104777	K4562115 CONTROLLER ASSEMBLY NXT2

NXT to NXT2 Conversion Kit

1

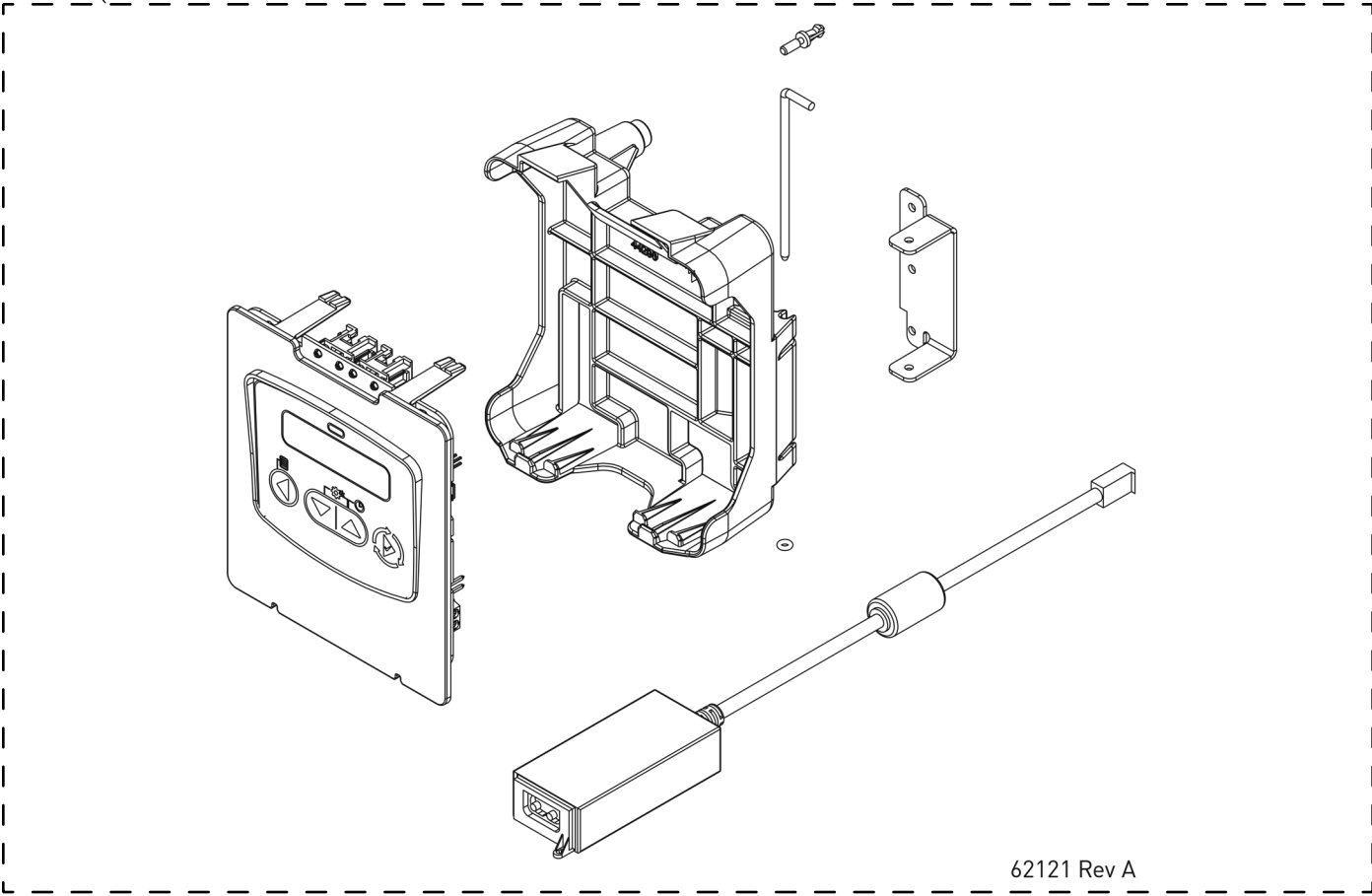

62121 Rev A

NXT TO NXT2 CONVERSION KIT			
ITEM NO.	QTY	ORDERING CODE	DESCRIPTION
1	1	68104778	K4562121-01 CONTROLLER ASSY CONV KIT NXT TO NXT2 W/ 24V US POWER SUPPLY

Replacement Parts - SXT Controller Assembly

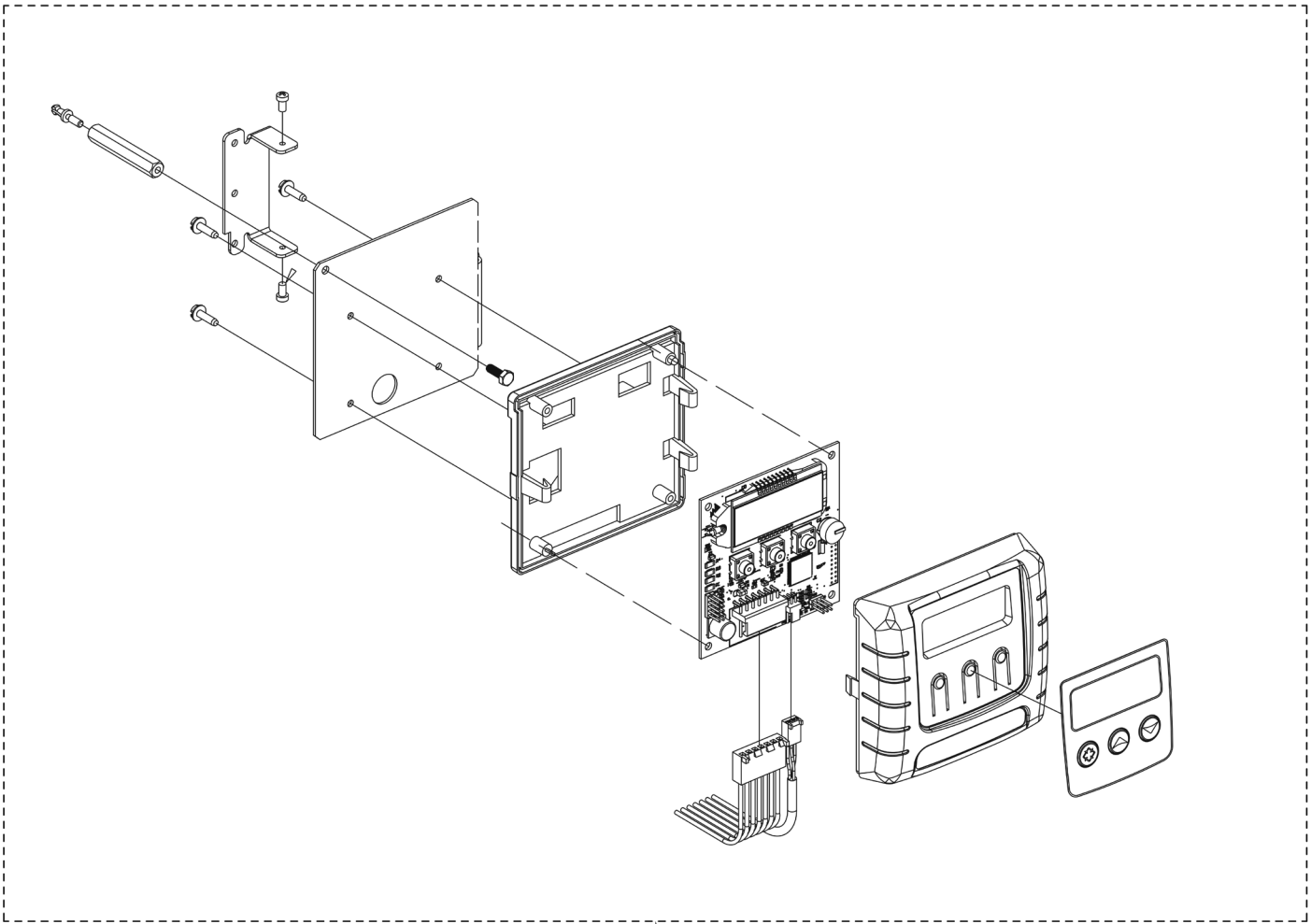

1

SXT CONTROLLER ASSEMBLY			
ITEM NO.	QTY	ORDERING CODE	DESCRIPTION
1	1	68104457	K4542778 SXT CONTROLLER F/ 2750/2850

Replacement Parts - 2750 Control Valve Body

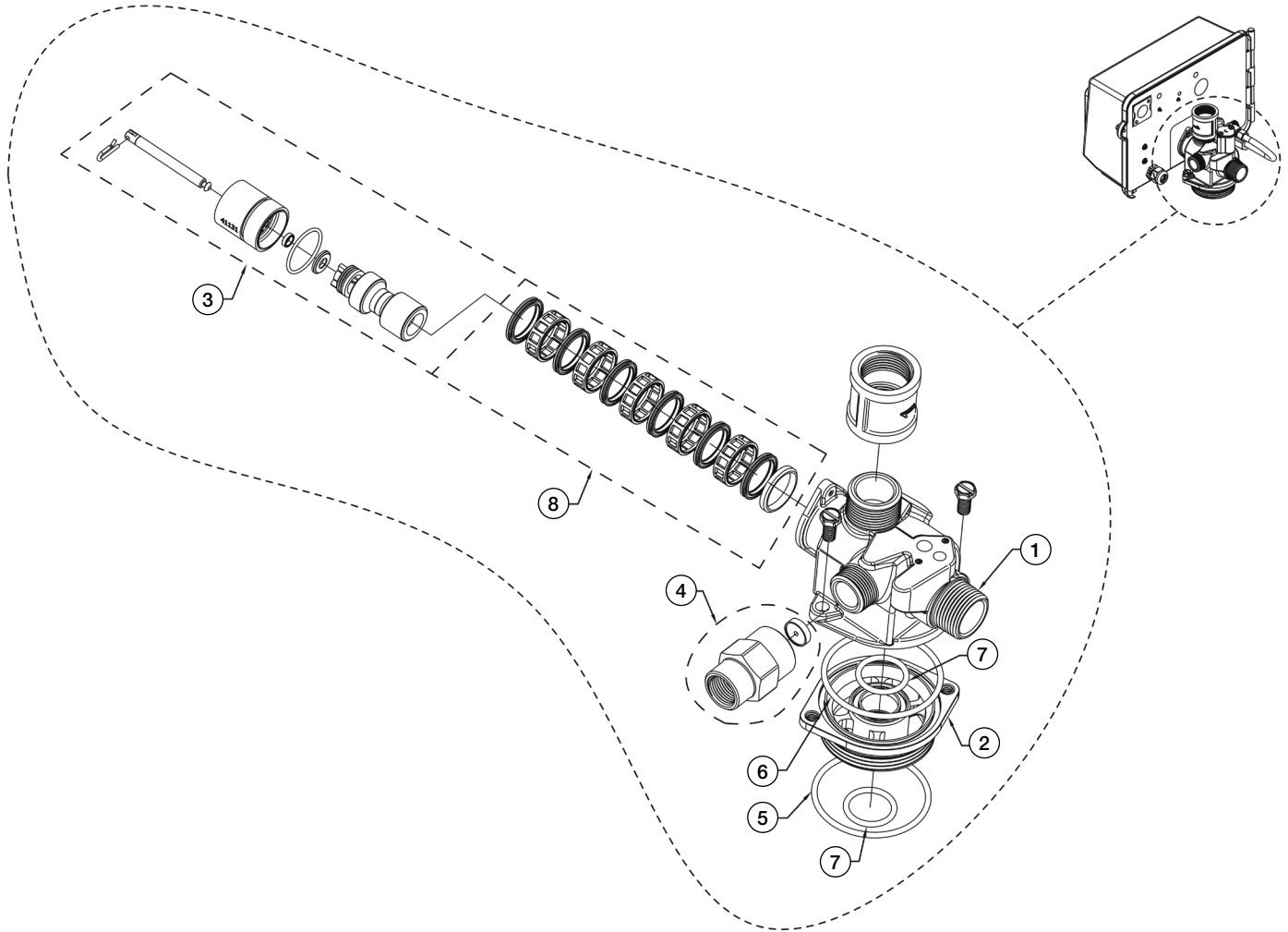

2750 DOWNFLOW CONTROL VALVE BODY ASSEMBLY			
ITEM NO.	QTY	ORDERING CODES	DESCRIPTION
1	1	-	VALVE BODY 2750
2	1	-	ADAPTER BASE 1" 2-1/2 INCH - 8 QUICK CONNECT
3	1	7300932	K4560090-HF PISTON ASSEMBLY F/ 2750 HWBP DOWN FLOW
4	1	68104599	K4560365 DRAIN FLOW CONTROLLER 3/4" F X 1/2" F NPT BLANK
4	1	68104600	K4560365-2.0 DRAIN FLOW CONTROLLER 3/4" F X 1/2" F NPT 2.0 GPM
4	1	68104601	K4560365-2.4 DRAIN FLOW CONTROLLER 3/4" F X 1/2" F NPT 2.4 GPM
4	1	68104602	K4560365-3.5 DRAIN FLOW CONTROLLER 3/4" F X 1/2" F NPT 3.5 GPM
4	1	68104603	K4560365-4.0 DRAIN FLOW CONTROLLER 3/4" F X 1/2" F NPT 4.0 GPM
4	1	68104604	K4560365-5.0 DRAIN FLOW CONTROLLER 3/4" F X 1/2" F NPT 5.0 GPM
4	1	68104605	K4560365-7.0 DRAIN FLOW CONTROLLER 3/4" F X 1/2" F NPT 7.0 GPM
5	1	68104072	K4510381 O-RING -231 F/ 2750 VALVE TO TANK
6	2	68104094	K4511208 O-RING -232
7	1	68104097	K4511710 O-RING -215 F/ 2750 DISTRIBUTOR PILOT
8	1	68104744	K4561671-00 SEAL & SPACER KIT F/ 2750

Replacement Parts - 1600 Brine System

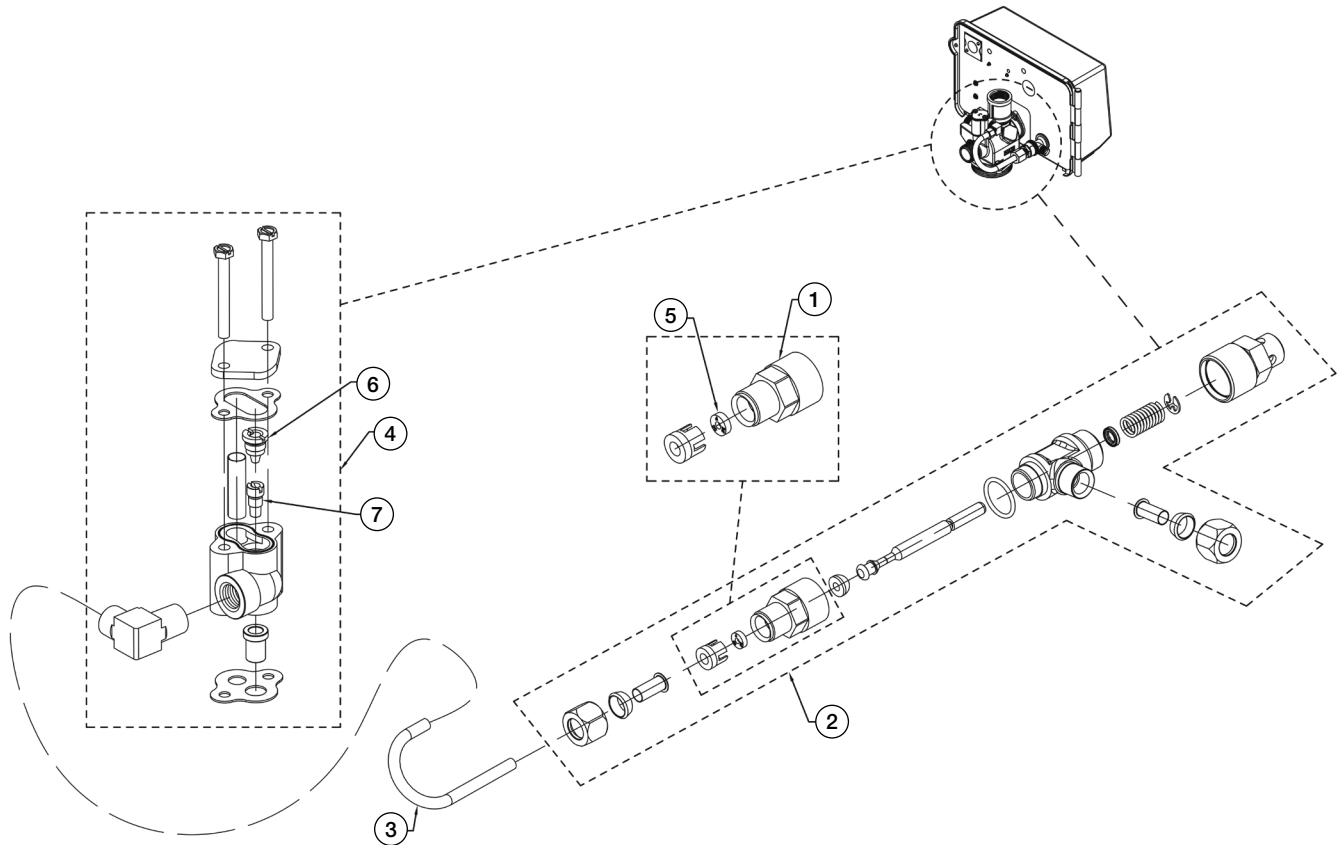

1600 INJECTOR & BRINE VALVE ASSEMBLY

ITEM NO.	QTY	ORDERING CODE	DESCRIPTION
1	1	68104482	K4560020-25 BRINE FLOW CONTROL ASSEMBLY .25 GPM F/1600/3600
1	1	68104483	K4560020-50 BRINE FLOW CONTROL ASSEMBLY .50 GPM F/1600/3600
1	1	68104484	K4560022-100 BRINE FLOW CONTROL ASSEMBLY 1.0 GPM F/5600/9000
2	1	68104490	K4560029 BRINE VALVE SHORT STEM 1600/ NO FLOW CONTROLLER
2	1	68104493	K4560029-100 BRINE VALVE SHORT STEM 1600 W/ 1.0 GPM FLOW CONTROLLER
2	1	68104494	K4560029-50 BRINE VALVE SHORT STEM 1600 W/ .50 GPM FLOW CONTROLLER
3	1	68104321	K4516508 BRINE TUBE 1600 F/2750 2850 2900S
4*	1	68104654	K4560480-03 INJECTOR ASSY 1600 #3 PLASTIC
4	1	68104655	K4560481-23 INJECTOR ASSY 1600 #3 S.S.
5	1	68104117	K4512094 BRINE FLOW WASHER .25 GPM
5	1	68104118	K4512095 BRINE FLOW WASHER .50 GPM
5	1	68104119	K4512097 BRINE FLOW WASHER 1.0 GPM
6	1	68104079	K4510913-00 INJECTOR NOZZLE #00 VIOLET
6	1	68104080	K4510913-000 INJECTOR NOZZLE #000 BROWN
6	1	68104081	K4510913-BL INJECTOR NOZZLE #2 BLUE
6	1	68104082	K4510913-G INJECTOR NOZZLE #4 GREEN
6	1	68104083	K4510913-R INJECTOR NOZZLE #0 RED
6	1	68104084	K4510913-W INJECTOR NOZZLE #1 WHITE
6	1	68104085	K4510913-Y INJECTOR NOZZLE #3 YELLOW
7	1	68104086	K4510914-00 INJECTOR THROAT #00 VIOLET
7	1	68104087	K4510914-000 INJECTOR THROAT #000 BROWN
7	1	68104088	K4510914-BL INJECTOR THROAT #2 BLUE
7	1	68104089	K4510914-G INJECTOR THROAT #4 GREEN
7	1	68104090	K4510914-R INJECTOR THROAT #0 RED
7	1	68104091	K4510914-W INJECTOR THROAT #1 WHITE
7	1	68104092	K4510914-Y INJECTOR THROAT #3 YELLOW

* 68104654 INJECTOR ASSEMBLY COMES WITH YELLOW INJECTOR NOZZLE & THROAT. PLEASE SPECIFY TO ONE OF OUR SPECIALISTS IF YOU REQUIRE A DIFFERENT NOZZLE & THROAT.

Replacement Parts - 1650 Brine System

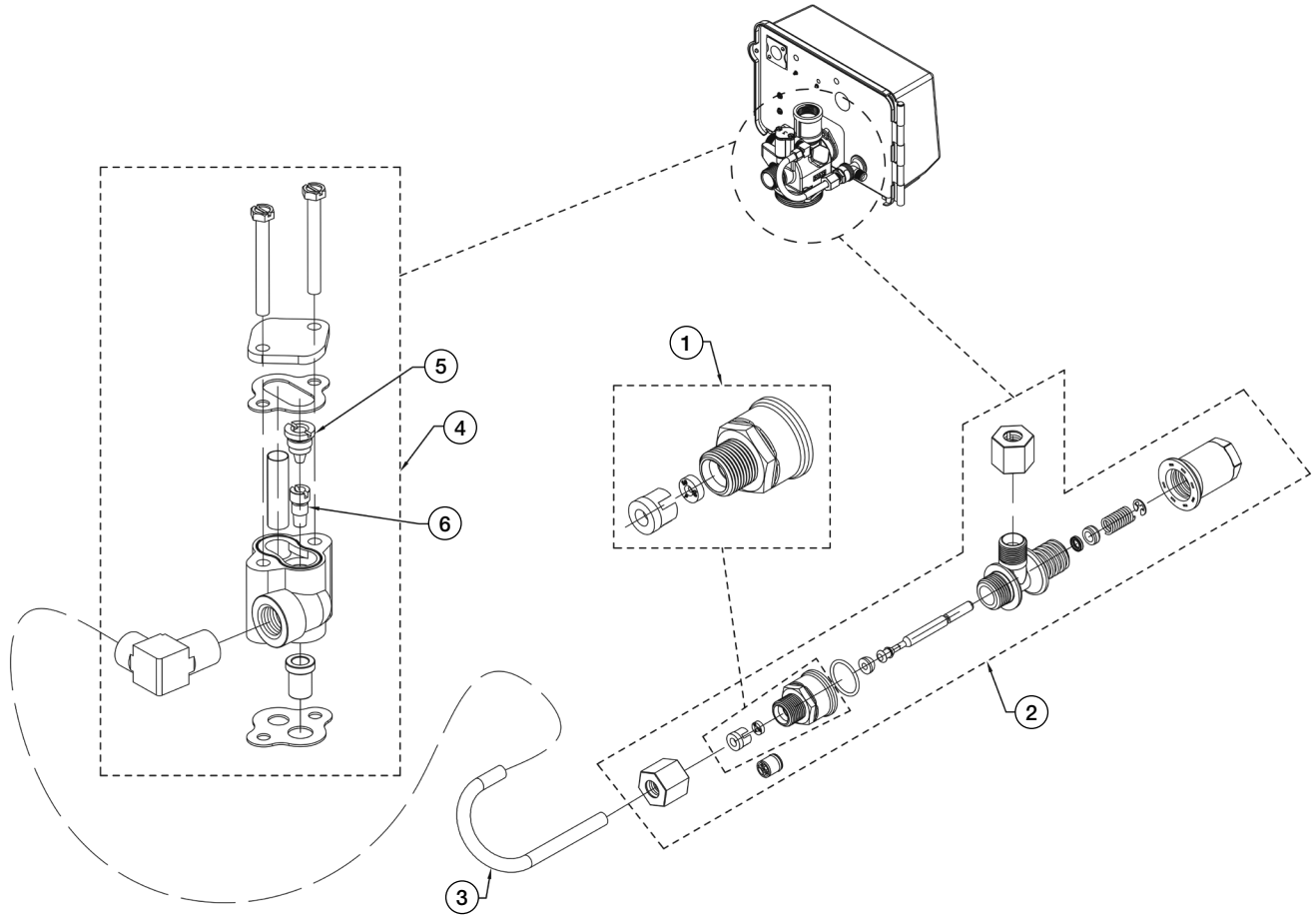

1650 INJECTOR & BRINE VALVE ASSEMBLY

ITEM NO.	QTY	ORDERING CODE	DESCRIPTION
1	1	68104474	K4560010-100 BLFC 1650 1.0 GPM PLASTIC
1	1	68104475	K4560010-50 BLFC 1650 .50 GPM PLASTIC
2	1	68104476	K4560011 BRINE VALVE 1650
2	1	68104477	K4560011-020 BRINE VALVE 1650 0.50 GPM
2	1	68104478	K4560011-030 BRINE VALVE 1650 1.0 GPM
3	1	68104321	K4516508 BRINE TUBE 1600 F/2750 2850 2900S
4*	1	68104654	K4560480-03 INJECTOR ASSY 1600 #3 PLASTIC
4	1	68104655	K4560481-23 INJECTOR ASSY 1600 #3 S.S.
5	1	68104079	K4510913-00 INJECTOR NOZZLE #00 VIOLET
5	1	68104080	K4510913-000 INJECTOR NOZZLE #000 BROWN
5	1	68104081	K4510913-BL INJECTOR NOZZLE #2 BLUE
5	1	68104082	K4510913-G INJECTOR NOZZLE #4 GREEN
5	1	68104083	K4510913-R INJECTOR NOZZLE #0 RED
5	1	68104084	K4510913-W INJECTOR NOZZLE #1 WHITE
5	1	68104085	K4510913-Y INJECTOR NOZZLE #3 YELLOW
6	1	68104086	K4510914-00 INJECTOR THROAT #00 VIOLET
6	1	68104087	K4510914-000 INJECTOR THROAT #000 BROWN
6	1	68104088	K4510914-BL INJECTOR THROAT #2 BLUE
6	1	68104089	K4510914-G INJECTOR THROAT #4 GREEN
6	1	68104090	K4510914-R INJECTOR THROAT #0 RED
6	1	68104091	K4510914-W INJECTOR THROAT #1 WHITE
6	1	68104092	K4510914-Y INJECTOR THROAT #3 YELLOW

* 68104654 INJECTOR ASSEMBLY COMES WITH YELLOW INJECTOR NOZZLE & THROAT. PLEASE SPECIFY TO ONE OF OUR SPECIALISTS IF YOU REQUIRE A DIFFERENT NOZZLE & THROAT.

Replacement Parts - 1" Plastic Electronic Turbine Meter Assembly

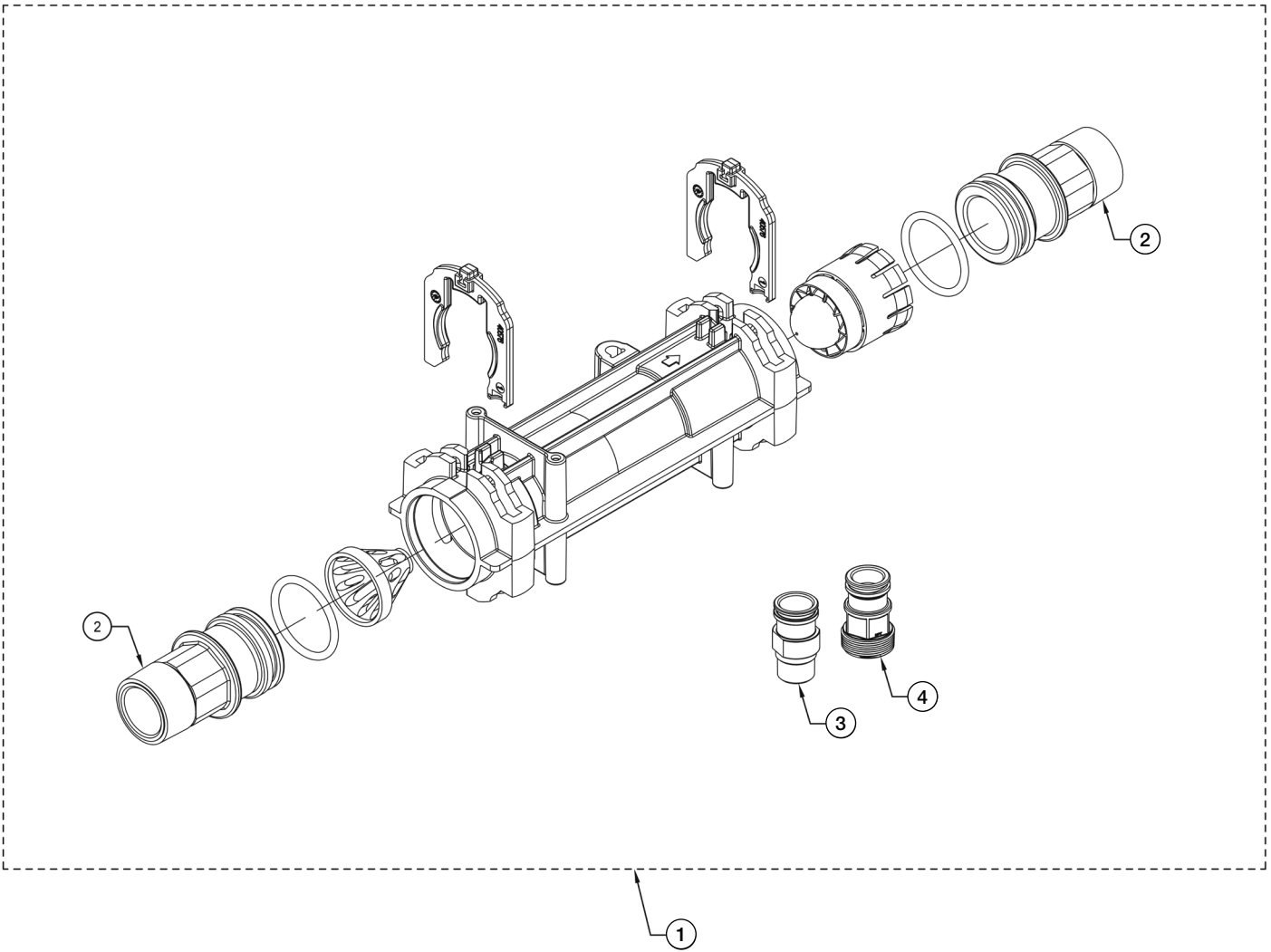

1 INCH PLASTIC ELECTRONIC TURBINE METER ASSEMBLY			
ITEM NO.	QTY	ORDERING CODE	DESCRIPTION
1	1	7300947	K4561560-01 METER ASSEMBLY ELECTRONIC TURBINE COMPLETE WITH 1" MNPT PLASTIC
2	2	68104435	K4541241-01 PLUMBING ADAPTOR PLASTIC 1" MNPT
3	2	68110409	41596 PLUMBING ADAPTOR BRASS 1" MNPT
4	2	68110410	41597 PLUMBING ADAPTOR BRASS 1.5" MNPT

Replacement Parts - 1" Stainless Steel Mech/Electronic Meter

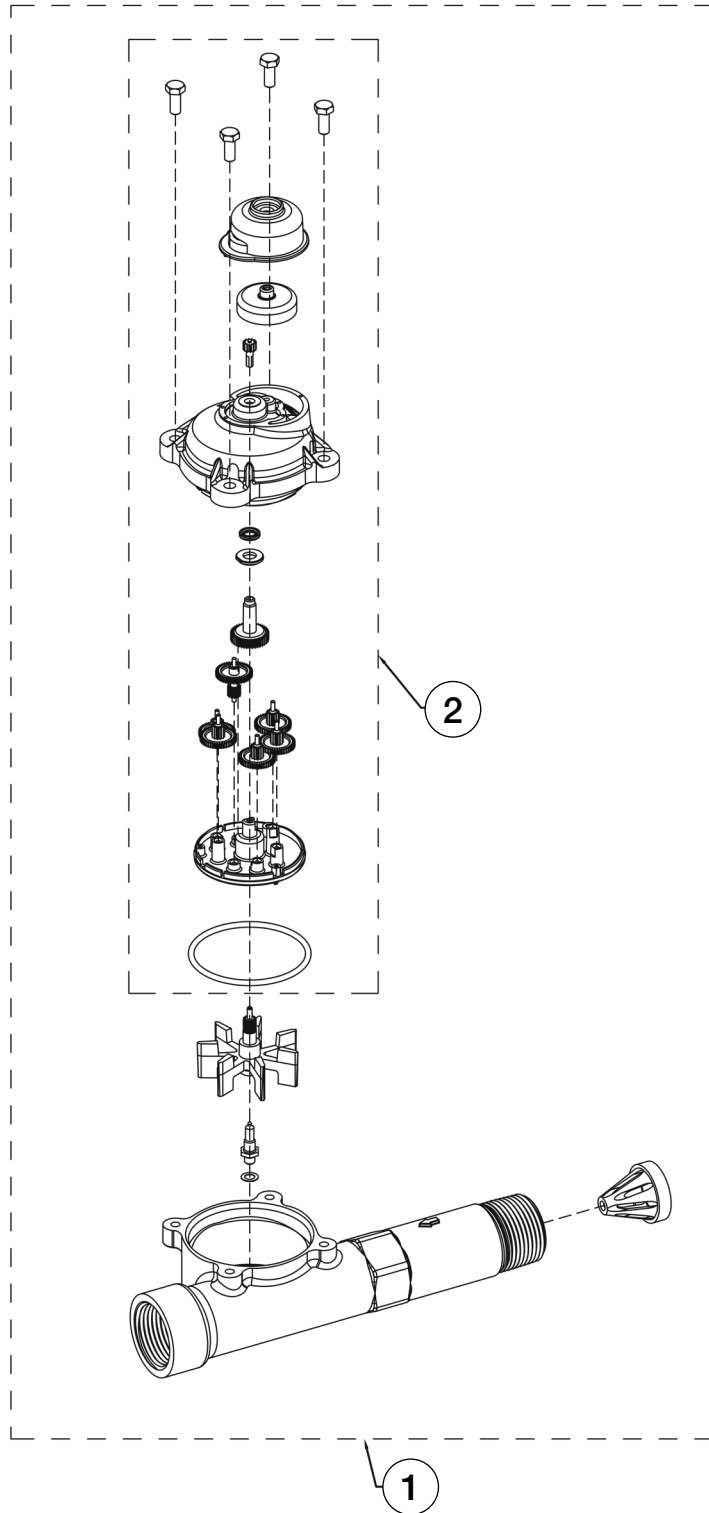

1 INCH STAINLESS STEEL METER ASSEMBLY			
ITEM NO.	QTY	ORDERING CODES	DESCRIPTION
1	1	68104752	K4561932-10 METER ASSEMBLY COMPLETE 1" STAINLESS STEEL MECH/ELEC STD RANGE
1	1	68104753	K4561932-11 METER ASSEMBLY COMPLETE 1" STAINLESS STEEL MECH/ELEC EXT RANGE
2	1	68110068	K4561936 METER DOME PLASTIC FOR 1" METER W/ O-RING MECH/ELEC

Troubleshooting

Problem	Cause	Correction
Water conditioner fails to regenerate	Electrical service to unit has been interrupted	Assure permanent electrical service (check circuit breaker, GFCI, fuse, plug, pull chain, or switch)
	Controller is defective	Replace controller
	Power failure	Reset time of day
Softener delivers hard water	By-pass valve is open	Close by-pass valve
	No salt is in brine tank	Add salt to brine tank and maintain salt level above water level
	Injector screen plugged	Clean injector screen
	Insufficient water flowing into brine tank	Check brine tank fill time and clean brine line flow control if plugged
	Hot water tank hardness	Repeated flushings of the hot water tank is required
	Leak at distributor tube	Make sure distributor tube is not cracked. Check O-ring and tube pilot
	Internal valve leak	Replace seals and spacers and/or piston
	Reserve capacity has been exceeded	Check salt dosage requirements and adjust program to provide additional reserve
	Meter is not measuring flow	Clean meter of foreign debris. Replace meter dome
Unit used too much salt	Improper salt setting	Check salt usage and salt setting
	Excessive water in brine tank	See- Problem "Excessive water in brine tank"
Loss of water pressure	Iron buildup in line to water conditioner	Clean line to water conditioner
	Iron buildup in water conditioner	Clean control and add mineral cleaner to mineral bed. Increase frequency of regeneration
	Inlet of control plugged due to foreign material broken loose from pipes by recent work done on plumbing system	Remove piston and clean control valve
Loss of mineral through drain line	Air in water system	Assure that well system has proper air eliminator control. Check for dry well condition
	Improperly sized drain line flow control	Check for proper drain rate
Iron in conditioned water	Fouled mineral bed	Check backwash, brine draw, and brine tank fill. Increase frequency of regeneration. Increase backwash time.
Excessive water in brine tank	Plugged drain line flow control	Clean flow control
	Plugged injector system	Clean injector and screen
	Controller not cycling	Replace controller
	Foreign material in brine valve	Replace brine valve seat and clean valve
	Foreign material in brine line flow control	Clean brine line flow control
Softener fails to draw brine	Drain line flow control is plugged	Clean drain line flow control
	Injector is plugged	Clean injector
	Injector screen plugged	Clean screen
	Line pressure is too low	Increase line pressure to 20psi
	Internal control leak	Change seals, spacers, and piston assembly
	Service adapter did not cycle	Check drive motor and switches
Control cycles continuously	Misadjusted, broken, or shorted switch	Determine if switch or controller is faulty and replace it, or replace complete power head
Resin and gravel in outlet water	Damaged lower distributor screen	Replace distributor screen
High service flow rate pressure drop	Resin damaged by chlorine/chloramine	Replace resin
	Foreign material in distributor screen	Replace all media and distributor screens

Troubleshooting- NXT2 Controller Error Codes

Error Codes and Troubleshooting

Detected Errors

If a communication error is detected, an Error Screen will appear.

- All units In Service remain in the In Service position.
- All units in Standby go to In Service.
- Any unit in Regeneration when the error occurs completes Regeneration and goes to In Service.
- No units are allowed to start a Regeneration Cycle while the error condition exists, unless they are manually forced into Regeneration.
- When an error is corrected and the error no longer displays (it may take several seconds for all of the units in a system to stop displaying the error message), the system returns to normal operation.

NOTE: During the error condition, the control continues to monitor the flow meter and update the volume remaining. Once the error condition is corrected, all units return to the operating status they were in prior to the error. Regeneration queue is rebuilt according to the normal system operation. Or, if more than one unit has been queued for regeneration, then the queue is rebuilt according to which one communicates first.

Message Displayed	Causes for Error	Correction
Error Valve Count Mismatch	Number of NXT2 detected does not match selected system type in Master Programming	Push correct valve settings in Master Settings
Motor Stall No Changes Detected in the Optical Sensor for 6 Seconds	The motor is on but no encoder pulses are detected within a given duration while homing	Check the P11 connection and trigger a manual regeneration
Motor Run-On No CAM Switch Change Detected	The motor is on but no encoder pulses are detected or CAM Switches change state within a given duration	Verify correct valve type is chosen. Trigger a manual regeneration
Optical Sensor Undesired change detected by the Optical Sensor	The motor is off but additional encoder pulses are detected	Trigger a manual regeneration
Over-Current Motor Over-Current is Detected	Motor current exceeds thresholds	Trigger a manual regeneration
Flow Meter Error Continuous Flow Detected	Flow exceeded specified threshold for a specific duration	Trigger a manual regeneration
Error Send/Receive Failure	During a setting push, a packet was missing	Reconnect communication cables and push setting in Master Settings
Error System Type Mismatch on Network	The system type among connected units does not match	Push correct system settings in Master Settings
Microcontroller Error	Calibration or manufacturing test was not performed	Contact your Watts representative
100 Days Without Regen	100 Days have expired without a regeneration	Trigger a manual regeneration

Troubleshooting - SXT Controller Error Codes

Error Code	Error Type	Cause	Reset and Recovery
0	Cam Sense Error	The valve drive took longer than 6 minutes to advance to the next regeneration position	<p>Unplug the unit and examine the powerhead. Verify that all cam switches are connected to the circuit board and functioning properly. Verify that the motor and drive train components are in good condition and assembled properly. Check the valve and verify that the piston travels freely. Replace/reassemble the various components as necessary.</p> <p>Plug the unit back in and observe its behavior. The unit should cycle to the next valve position and stop. If the error re-occurs, unplug the unit and contact technical support.</p>
1	Cycle Step Error	The control experienced an unexpected cycle input	<p>Unplug the unit and examine the powerhead. Verify that all cam switches are connected to the circuit board and functioning properly. Enter Master Programming mode and verify that the valve type and system type are set correctly with regard to the unit itself.</p> <p>Step the unit through a manual regeneration and verify that it functions correctly. If the error re-occurs unplug the unit and contact technical support.</p>
2	Regen Failure	The system has not regenerated for more than 99 days (or 7 days if the Control Type has been set to Day-of- Week)	<p>Perform a Manual Regeneration to reset the error code. If the system is metered, verify that it is measuring flow by running service water and watching for the flow indicator on the display. If the unit does not measure flow, verify that the meter cable is connected properly and that the meter is functioning properly.</p> <p>Enter a Master Programming Mode and verify that the unit is configured properly. As appropriate for the valve configuration, check that the correct system capacity has been selected, that the day override is set properly, and that meter is identified correctly. If the unit is configured as a Day-of-Week system, verify that at least one day is set ON. Correct the settings as necessary.</p>
3	Memory Error	Control board memory failure	<p>Perform a Master Reset and reconfigure the system via Master Programming Mode. After reconfiguring the system, step the valve through a manual regeneration. If the error re-occurs unplug the unit and contact technical support.</p>
UD	Upper Drive Sync	Power failure install programming change	Valve will automatically recover.

Water Softener Flow Diagrams

1 Service Position

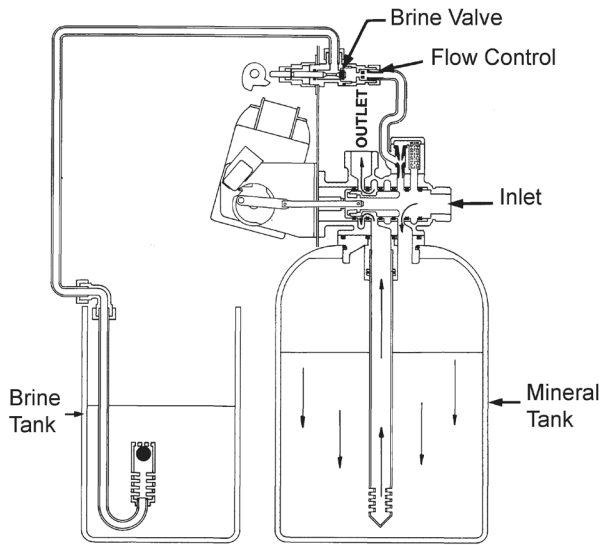

4 Slow Rinse Position

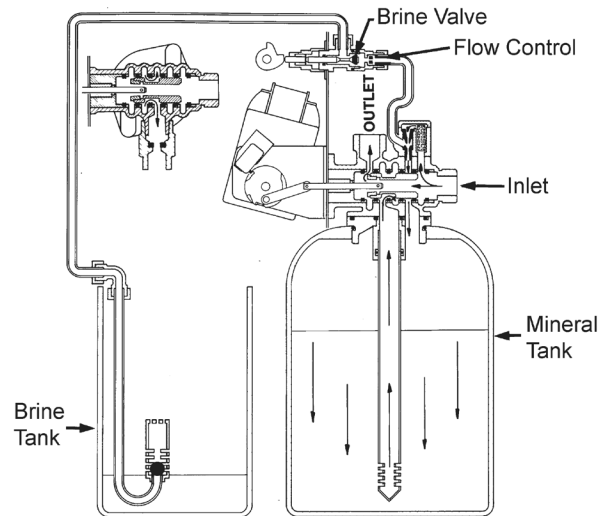

2 Backwash Position

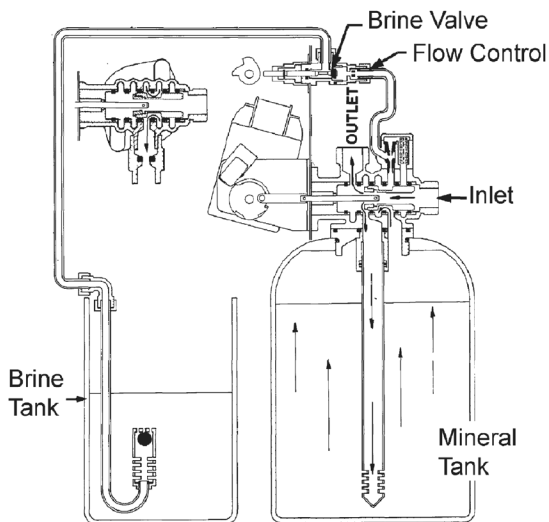

5 Rapid Rinse Position

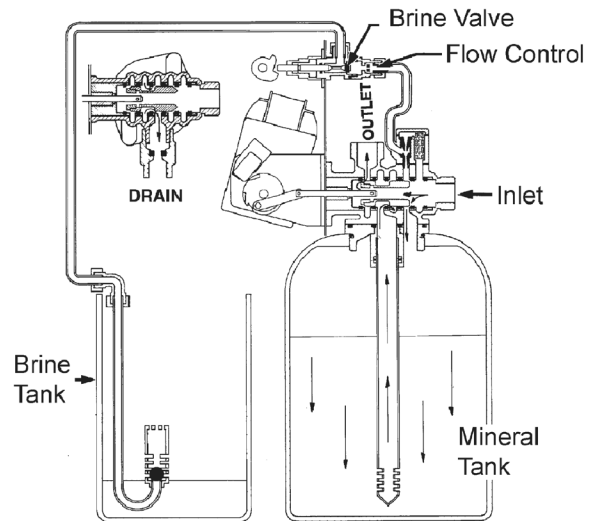

3 Brine Position

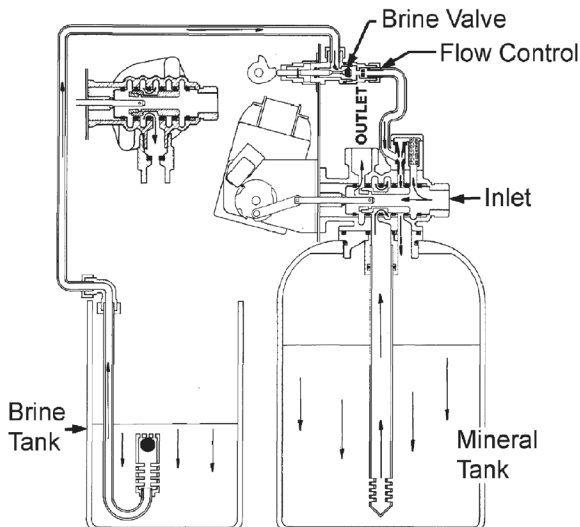

6 Brine Tank Fill Position

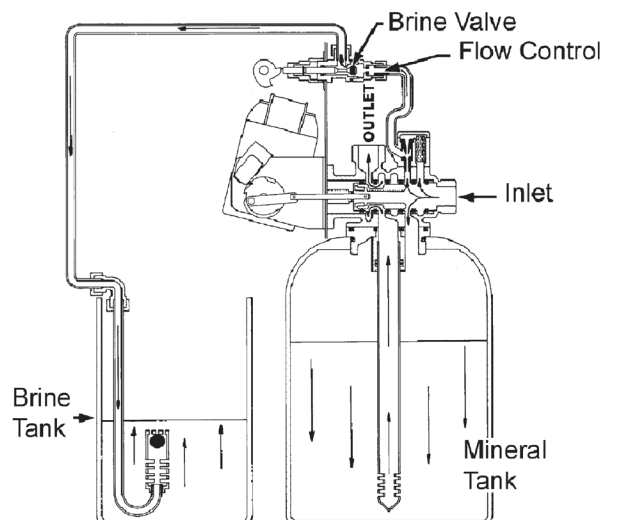

Flow Data and Injector Draw Rates - Down Flow

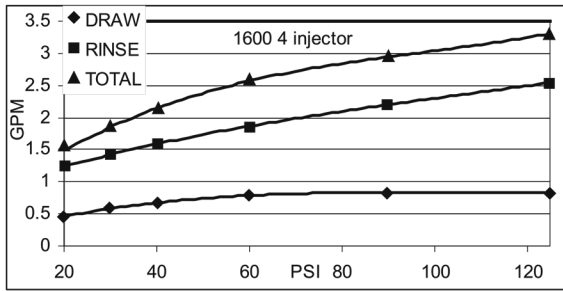
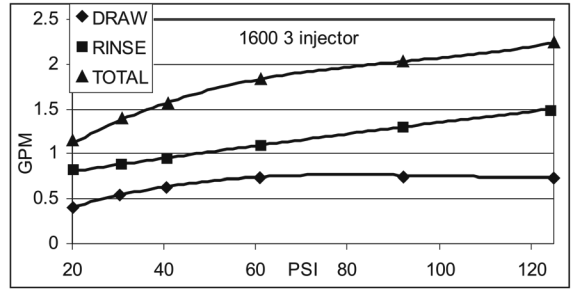
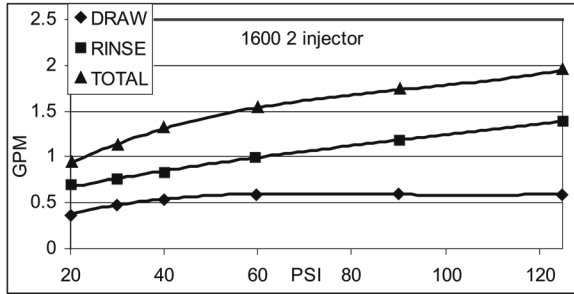
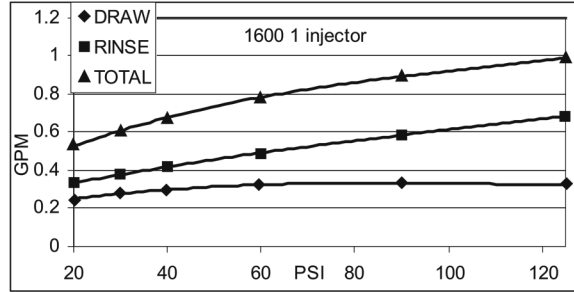
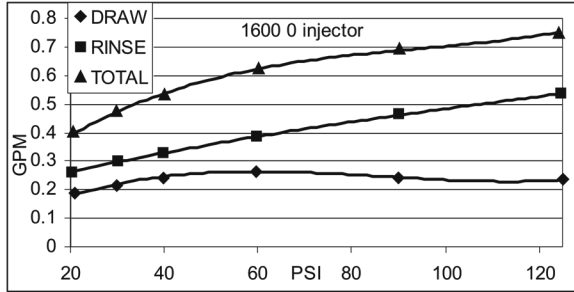

TR20391_REVA

Injector Nozzle and Throat Chart for 1600 Brine Systems

1600 Brine System

Standard

Size	Color
#0	Red
#1	White
#2	Blue
#3	Yellow
#4	Green

WATER SOFTENERS/FILTERS Limited Warranty:

The Company warrants each fiberglass tank 13 inches in diameter and smaller to be free from defects in material and workmanship under normal usage for a period of ten years from the date of original shipment.

The Company warrants each fiberglass tank 14 inches in diameter and larger to be free from defects in material and workmanship under normal usage for a period of five years from the date of original shipment.

The Company warrants any size Salt Tank (Brine Tank) to be free from defects in material and workmanship under normal usage for a period of five years from the date of original shipment.

The Company warrants each Control valve to be free from defects in material and workmanship under normal usage for a period of five years from the date of original shipment.

The Company warrants diaphragm valve nests and related controls to be free from defects in material and workmanship under normal usage for a period of one year from the date of original shipment.

The Company warrants all other components to be free from defects in material and workmanship under normal usage for a period of one year from the date of original shipment.

Water softener resins subjected to iron, manganese and chlorine levels greater than 1ppm are expressly not covered by this warranty. Manganese greensand media and expendable media such as activated carbon, Filox[®], Micro-Z[®] and neutralizing media are also not covered by this warranty. In the event of a covered defect within the warranty period, the Company will, at its option, replace or recondition the product without charge.

Disclaimer of Warranty. THE WARRANTY SET FORTH HEREIN IS GIVEN EXPRESSLY AND IS THE ONLY WARRANTY GIVEN BY THE COMPANY WITH RESPECT TO THE PRODUCT. THE COMPANY MAKES NO OTHER WARRANTIES, EXPRESS OR IMPLIED. THE COMPANY HEREBY SPECIFICALLY DISCLAIMS ALL OTHER WARRANTIES, EXPRESS OR IMPLIED, INCLUDING BUT NOT LIMITED TO THE IMPLIED WARRANTIES OF MERCHANTABILITY AND FITNESS FOR A PARTICULAR PURPOSE.

Limitation of Liability. The remedy described in the first paragraph of this warranty shall constitute the sole and exclusive remedy for breach of warranty, and the Company shall not be responsible for any incidental, special or consequential damages, including without limitation, lost profits or the cost of repairing or replacing other property which is damaged if this product does not work properly, other costs resulting from labor charges, delays, vandalism, negligence, fouling caused by foreign material, damage from adverse water conditions, chemical, or any other circumstances over which the Company has no control. This warranty shall be invalidated by any abuse, misuse, misapplication, improper installation or improper maintenance or alteration of the product

Some States do not allow limitations on how long an implied warranty lasts, and some States do not allow the exclusion or limitation of incidental or consequential damages. Therefore the above limitations may not apply to you. This Limited Warranty gives you specific legal rights, and you may have other rights that vary from State to State. You should consult applicable state laws to determine your rights. **SO FAR AS IS CONSISTENT WITH APPLICABLE STATE LAW, ANY IMPLIED WARRANTIES THAT MAY NOT BE DISCLAIMED, INCLUDING THE IMPLIED WARRANTIES OF MERCHANTABILITY AND FITNESS FOR A PARTICULAR PURPOSE, ARE LIMITED IN DURATION TO ONE YEAR FROM THE DATE OF ORIGINAL SHIPMENT.**



USA: T: (800) 224-1299 • F: (978) 794-1848 • Watts.com/PureWater

Canada: T: (888) 208-8927 • F: (905) 481-2316 • Watts.ca/PureWater

Latin America: T: (52) 55-4122-0138 • Watts.com/PureWater