

# **SERIES 7 DUAL CHECK BACKFLOW PREVENTERS**



**PRODUCT GUIDE**

## Protecting the Public Water Supply

Both public water supply officials and consumers need to protect the public supply of safe drinking water. As a public water supply professional, you need to do everything in your power to prevent the reverse flow associated with:

- ◆ Main line flushing (maintenance)
- ◆ Firefighting (emergency)
- ◆ Main line rupture or blowout (disaster)

Such activities and occurrences can siphon domestic water systems, drawing every conceivable fluid connected to the user's system back into the public water supply.

The Series 7 Backflow Preventers provide cost-effective backflow protection of the public water supply when used according to the local or state plumbing code

requirements. As part of your comprehensive containment program, you should require the installation of a Series 7 unit as a condition for the user to receive service from the public water system. This three-step program should ideally include:

### The first line of defense

The user certifies that his/her domestic water system complies with the local plumbing codes.

### The second line of defense

The user installs a dual check backflow preventer at the water meter as prescribed by the supplier of safe drinking water.

### The third line of defense – education

The supplier of water provides educational material that teaches the user how to avoid contaminating or polluting the drinking water once it has entered his domestic water system.

## Presenting Series 7 Dual Check Backflow Preventers from Watts

To ensure the safety of drinking water, there can be no room for compromise. That's why Watts provides the incomparable Series 7 Backflow Preventers with dual check security. Installed at the residential water meter or service entrance, the Series 7 Backflow Preventers offer:

- ◆ Low pressure drop.
- ◆ Easy maintenance and service.
- ◆ Wide selection of types, sizes, and connections.

Our unique check modules put our Series 7 Backflow Preventers distinctly ahead of other residential containment devices. With their innovative design, most Series 7 models offer a full range of features, including:

- ◆ Chloramine resistance – for long life under the harshest water conditions.
- ◆ Complete modularity – for easy maintenance.
- ◆ Limit stops – to prevent damage from thermal expansion.
- ◆ Center and edge guides – to ensure repeatable seating and minimize localized wear.
- ◆ No exposed screws or threads – to eliminate corrosion potential and improve serviceability.

Of course, the Series 7 Dual Check Backflow Preventers embody the quality engineering of Watts, a world leader in valve technology. And you have the confidence of knowing the Series 7 are ASSE 1024 and CSA B64.6 Certified. So when you need to be sure you have the most reliable residential containment products, specify the Watts Series 7 backflow preventers.

Features	Model/Series					
	7	L7	O7S	7B	7C	CU7
Center Stem Guides	●	●	●	●	●	●
Edge Guides	●		●	●	●	●
Chloramine Resistant Components	●	●	●	●	●	●
Modular Design	●		●	●	●	●
Limit Stops	●	●	●			●
Stainless Steel Springs	●	●	●	●	●	●
Replaceable Seats	●		●	●	●	●
No Exposed Screws Or Threads	●	●	●	●	●	●

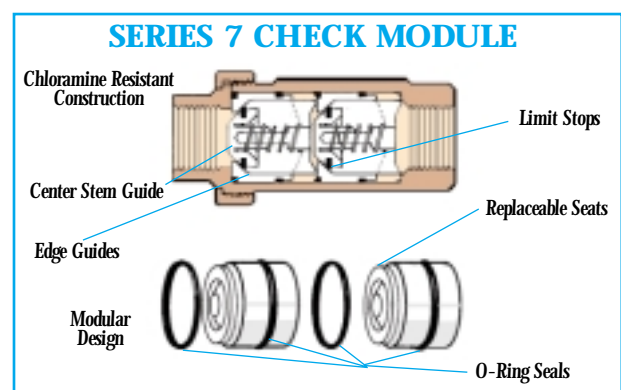

# SERIES 7

## Dual Check Backflow Preventers

Size: 1/2" through 1 1/4" (13-32mm)

Available with an extensive combination of inlet/outlet sizes, types of thread, and end connections –including retrofit compression fittings and hose connections–the Series 7 can be installed in a variety of piping configurations, and in conjunction with a wide range of meter horns, copper setters, and meter boxes.

### DESCRIPTION

The straight line, poppet-type construction of the Series 7 minimizes pressure drop and provides smooth flow characteristics. It can be installed horizontally or vertically. It is not adversely affected by normal line pressure surges, will not cause water hammer, and operates without chatter or vibration.

### STANDARDS



Tested and certified to meet ANSI/ASSE Standard 1024. CSA Certified to Standard No. B64.6.

Important: Inquire with governing authorities for local installation requirements.

### SPECIFICATIONS

The dual check backflow preventer shall meet the domestic requirements of ANSI/ASSE Standard 1024, and bear the seal of approval. It shall be bronze-bodied and include not less than one union, with the union nut drilled to accept a tamper-proofing lock wire. A brass identification tag indicating direction of flow shall be securely attached to the valve body by corrosion-resistant mechanical fasteners. The dual check shall be Watts Regulator Company's Series 7. (Please select the model best suited to your application.)

### PRODUCT AVAILABILITIES

Series 7: Inlet/Outlet Connections – Types available, ordering code, sizes available.

Connection Type	Connection Code	Sizes Available	
		inches	mm
National Pipe Thread Female	2	1/2, 3/4, 1	13,19,25
National Pipe Thread Male	3	1/2, 3/4, 1, 1 1/4	13,19,25,31
Meter Thread Female*	4	3/4, 1, 1 1/4	19,25,31
Meter Thread Male*	5	3/4, 1, 1 1/4	19,25,31
Pack Joint Female	6	3/4, 1	19,25
Pack Joint Male	7	3/4, 1	19,25
Female Solder	8	3/4, 1	19,25
Male Solder	9	3/4, 1	19,25
Female Meter Thread (Swivel)	10	3/4, 1, 1 1/4	19,25,31
Male Hose Thread	11	3/4	19
Female Hose Thread	12	3/4	19
Male Meter Yoke Thread	13	3/4	19

\* See "How To Order" on pages 10, 11  
Union (U) Connections available on all inlet/outlet types and sizes.

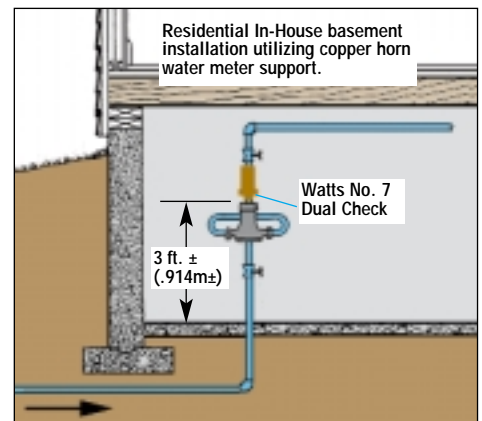
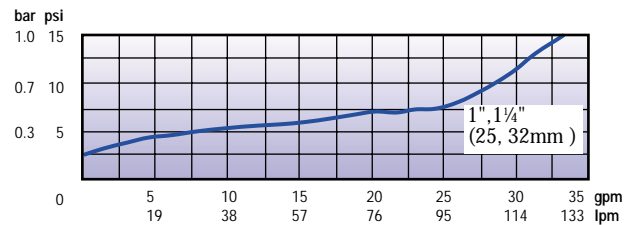
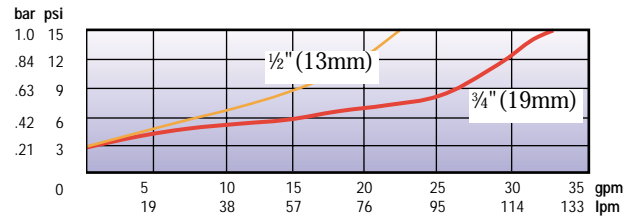

### MATERIALS

Cast bronze body, durable plastic check modules, injection molded of acetyl resin and PPO, silicone discs and Buna 'N' seals, stainless steel springs, one union and "O" ring union seal. (3/4" size also available in brass. See Series 7B p.7)

### PRESSURE / TEMPERATURE

Max. pressure: 150 psi (10 bars). Min. pressure: 10 psi (69 kPa). Working temperature: 33°F to 140°F sustained; intermittent to 180°F (0.6°C to 82.2°C)

### DIMENSIONS / WEIGHT

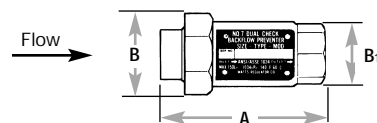

A		B		B1		Weight	
inches	mm	inches	mm	inches	mm	lbs.	kgs.
4 3/8	110	2 1/8	58	1 1/4	44	1.75	.79

# SERIES L7

## In-Line Testable/Serviceable Dual Check Backflow Preventers Sizes: 3/4" and 1" (19, 25mm)



### DESCRIPTION

The ideal solution for residential containment applications that require in-line testable and serviceable dual check backflow preventers.

### STANDARDS

Tested and certified to meet ANSI/ASSE Standard 1024.



Important: Inquire with governing authorities for local installation requirements.

### SPECIFICATIONS

The dual check backflow preventer shall be designed under the ASSE Standard 1024. It shall be bronze-bodied with top and bottom guided plastic check assemblies. The dual check shall have three plugged test ports and shall be capable of being tested in-line. Dual check shall have two top-mounted covers for in-line service. Check assembly shall be designed without screws located within the water-way and shall be fully guided throughout its range of travel. Dual check shall be Watts Regulator Company's Series L7. (Please select the model best suited to your application.)

### PRODUCT AVAILABILITIES

Series L7: Inlet Connections - Types available, ordering code, sizes available

Connection Type	Connection Code	Sizes Available	
		inches	mm
National Pipe Thread Female	2	3/4, 1	19, 25
National Pipe Thread Male	3	3/4, 1	19, 25
Meter Thread Female *	4	3/4, 1	19, 25
Meter Thread Male *	5	3/4, 1	19, 25
Pack Joint Female	6	3/4, 1	19, 25
Pack Joint Male	7	3/4, 1	19, 25
Female Solder	8	3/4, 1	19, 25
Male Solder	9	3/4, 1	19, 25
Female Meter Thread (Swivel)	10	3/4, 1	19, 25
Male Hose Thread	11	3/4, 1	19, 25
Female Hose Thread	12	3/4, 1	19, 25

Series L7: Outlet Connections - Types available, ordering code, sizes available

National Pipe Thread Female	2	3/4, 1	19, 25
Meter Thread Female	4	3/4, 1	19, 25
Female Hose Thread	12	3/4	19

See "How To Order" on pages 10 & 11.

Union (U) Connections available on all inlet/outlet types and sizes

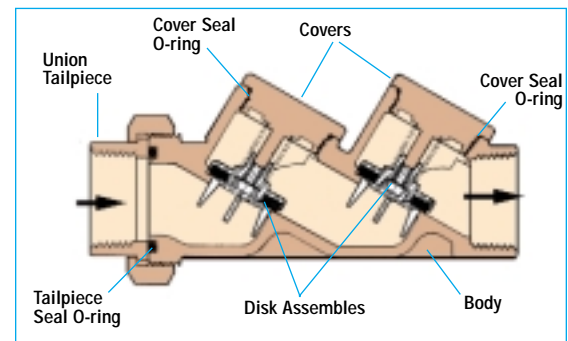
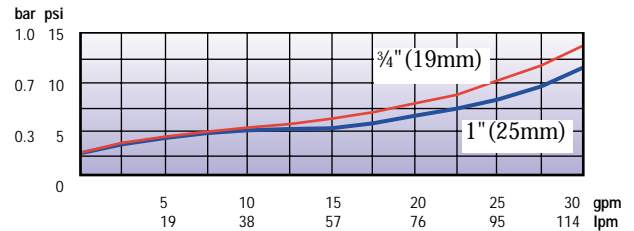

### MATERIALS

Cast bronze body, plastic check assemblies, silicone discs and stainless steel springs.

### PRESSURE / TEMPERATURE

Maximum pressure: 175 psi (12 bars).

Minimum pressure: 10 psi (69 kPa).

Working temperature: 33°F to 140°F sustained; intermittent to 180°F (0.6°C to 60°C sustained; intermittent to 82.2°C).

\* When ordering No. 7 Valves with Meter Thread Connections be sure to order the meter connections one size larger than meter.

### Examples:

For 1/2" (13mm) and 3/8" (16mm) water meter; order 3/4" (19mm) meter thread connection.

For 5/8" (16mm) and 3/4" (19mm) water meter; order 1" (25mm) meter thread connection.

For 1" (25mm) water meter; order 1 1/4" (32mm) meter thread connection.

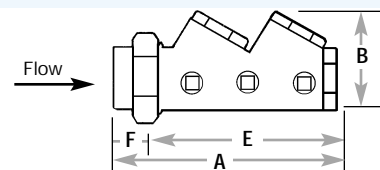

Size		A		B		E		F		Weight	
inches	mm	inches	mm	inches	mm	inches	mm	inches	mm	lbs.	kgs.
3/4	19	5 3/4	146	2 5/8	67	4 7/8	124	3/4	19	2.3	1.0
1	25	5 3/4	146	2 5/8	67	4 15/16	124	1	25	2.3	1.0

# SERIES 07S

## Residential Fire Sprinkler System Dual Check Backflow Preventers Size: 1" and 1¼" (25, 32mm)

### DESCRIPTION

Installed at the residential fire sprinkler service connection to the main, Series 07S Dual Check Backflow Preventers protect the water supply against polluted water being siphoned back from the sprinkler system.

### STANDARDS



Tested and certified under ANSI/ASSE Standard 1024, CSA Certified to Standard No. B64.6, UL Classified file # EX3185, and complies with NFPA Standard 13D for flow requirements to residential fire sprinklers. (1" Size only)

Important: Inquire with governing authorities for local installation requirements.

### SPECIFICATION

The dual check backflow preventer shall meet the requirements of ANSI/ASSE Standard 1024 and be UL Classified. It shall be bronze-bodied and feature replaceable seats and silicone seat discs. The springs shall be captured to prevent injury. The valve shall be capable of flow rate in excess of 50 gpm. Pressure drop at 30 gpm shall not exceed 6 psi. An identification tag shall be securely attached to the body by corrosion-resistant mechanical fasteners and a union connection shall be provided. The dual check shall be Watts Regulator Company's No. 07S.

### PRODUCT AVAILABILITIES

Series 07S: Inlet Connections - Types available, ordering code, sizes available

Connection Type	Connection Code	Sizes Available	
		inches	mm
Meter Thread Female	4	1, 1¼	25, 32
National Pipe Thread Male	2	1, 1¼	25, 32

Series 07S: Outlet Connections - Types available, ordering code, sizes available

Meter Thread Male	5	1, 1¼	25, 32
National Pipe Thread Male	3	1, 1¼	25, 32

See "How To Order" on pages 10, 11

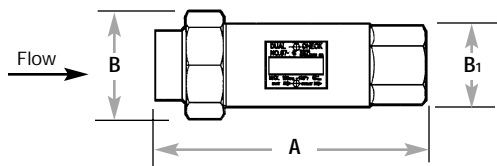

A		B		B <sub>1</sub>		Weight	
inches	mm	inches	mm	inches	mm	lbs.	kgs.
6¾	171	2 <sup>13</sup> / <sub>16</sub>	71	2	50	3	1.36

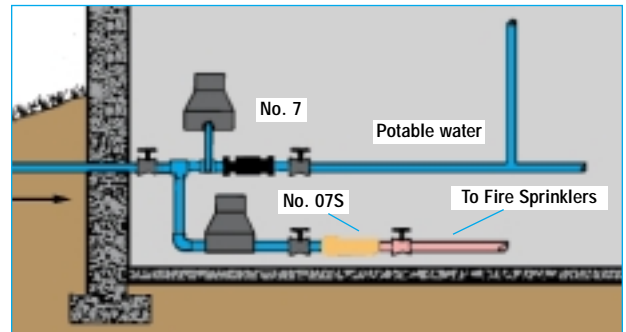
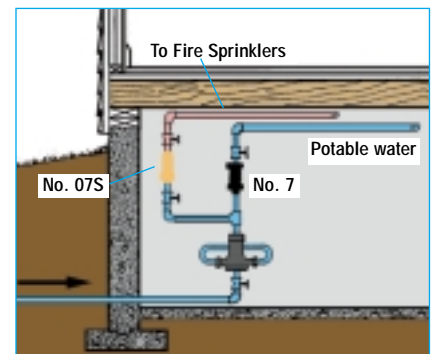
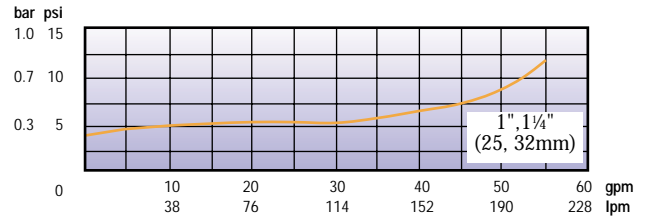

### MATERIALS

Cast bronze body, durable plastic check modules, silicone discs and Buna 'N' seals, stainless steel springs, one union and "O" ring union seal.

### PRESSURE / TEMPERATURE

Maximum pressure: 175 psi (12 bars).

Minimum pressure: 10 psi (69 kPa).

Working temperature: 33°F to 140°F sustained; intermittent to 180°F (0.6°C to 60°C sustained; intermittent to 82.2°C).

Maximum recommended flow: 50 gpm(190 lpm).

# SERIES CU7

## Copper-bodied Dual Check Backflow Preventer

Sizes: 1/2" through 1" (13-25mm)

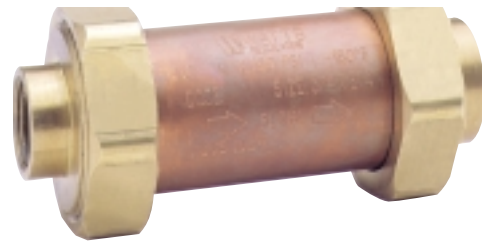

### DESCRIPTION

The straight line, poppet-type construction of the Cu7 minimizes pressure drop and provides smooth flow characteristics. It can be installed horizontally or vertically. The copper body of the Series Cu7 is lead free and is of a time proven durable material. All models are standardly furnished with double unions for ease of installation and repair.

### STANDARDS

Tested and certified to meet ANSI/ASSE Standard 1024.



### SPECIFICATIONS

The dual check backflow preventer shall meet ASSE 1024. The valve body shall be of copper tube construction and shall be furnished with double unions to facilitate installation. The check module shall be of a modular design and shall include limit stops to prevent over compression or damage to the check valves due to water hammer or thermal expansion. Each check valve shall be both center and edge-guided to ensure repeatable seating and minimize localized wear. The dual check shall be Watts Regulator Company's Series Cu7.

### PRODUCT AVAILABILITIES

Series CU7: Inlet/Outlet Connections - Types available, ordering code, sizes available

Connection Type	Connection Code	Sizes Available	
		inches	mm
National Pipe Thread Female	2	1/2", 3/4", 1"	13, 19, 25
National Pipe Thread Male	3	1/2", 3/4", 1"	13, 19, 25
Meter Thread Female*	4	3/4", 1"	19, 25
Meter Thread Male*	5	3/4", 1"	19, 25
Female Solder	8	3/4", 1"	19, 25
Female Meter Thread (Swivel)	10	3/4", 1"	19, 25

See "How to Order" on pages 10, 11.

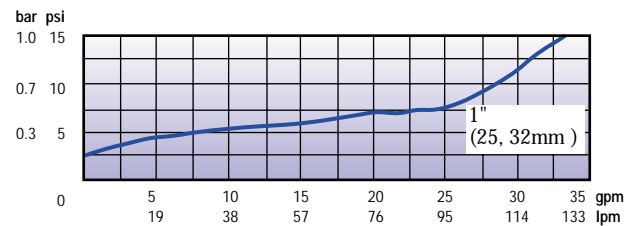
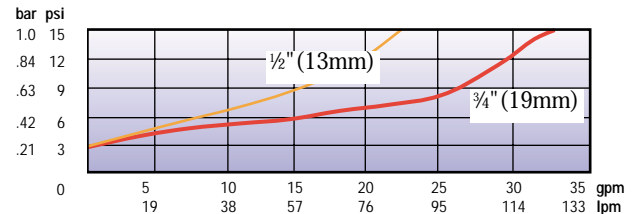

### MATERIALS

Copper body, corrosion resistant plastic check modules, silicone discs and Buna 'N' seals, stainless steel springs.

### PRESSURE / TEMPERATURE

Maximum Pressure: 175 psi (12 bars)

Minimum Pressure: 10 psi (69 kPa)

Working Temperature: 33 to 180°F (.6 to 82°C) continuous.

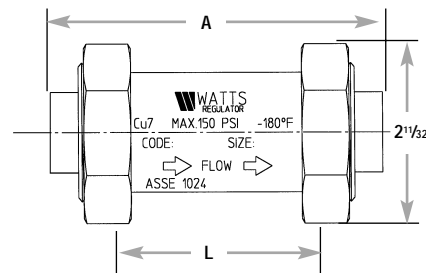

Size		Model	A		L		Weight	
in.	mm		in.	mm	in.	mm	lbs.	kg.
1/2	13	Cu7U2-U2	4 1/16	113	2 1/16	69	1.7	3.7
3/4	19	Cu7U2-U2	4 7/16	113	2 1/16	69	1.7	3.7
1	25	Cu7U2-U2	4 11/16	119	2 1/16	69	2.0	4.4

# MODEL 7B

## Dual Check Backflow Preventers (Brass)

Size: 3/4" (19mm)

### DESCRIPTION

Dual Check Series 7B Backflow Preventers feature a similar design to Series 7 (see page 2), but are constructed of machined brass rather than bronze.

### STANDARDS

Tested to meet or exceed the performance requirements of ANSI/ASSE Standard 1024 for "Dual Check Valve Type Backflow Preventers."

Important: Inquire with governing authorities for local installation requirements.

### SPECIFICATIONS

The dual check backflow preventer shall be installed at the water meter or service entrance to prevent reverse flow of water into the potable domestic water system. These devices shall consist of two independently-acting check valves, internally spring-loaded and center stem guided to a normally closed position with silicone discs. Designed and constructed to operate under intermittent or continuous pressure conditions. The dual check backflow preventer shall meet the domestic requirements of ANSI/ASSE Standard 1024. The dual check shall be Watts Regulator Company 3/4" (19mm) No. 7B.

### PRODUCT AVAILABILITIES

Series 7B: Inlet Connections – Types available, ordering code, sizes available.

Connection Type	Connection Code	Sizes Available	
		inches	mm
(U) National Pipe Thread Female	2	3/4	19

Series 7B: Outlet Connection – Types available, ordering code, sizes available.

National Pipe Thread Female	2	3/4	19
-----------------------------	---	-----	----

See "How to Order" on pages 10, 11.

Union (U) Connections available on all inlet/outlet types and sizes.

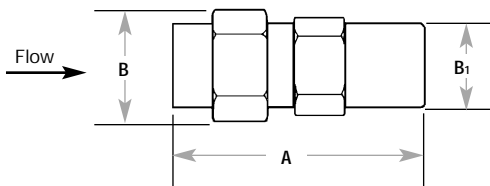

A		B		B <sub>1</sub>		Weight	
inches	mm	inches	mm	inches	mm	lbs.	kgs.
4	100	1 1/2	38	1 1/4	32	1.7	.49

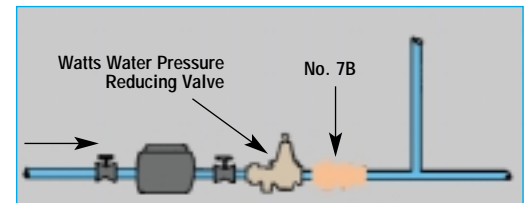
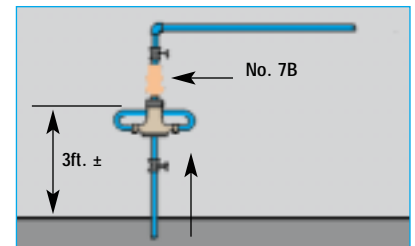
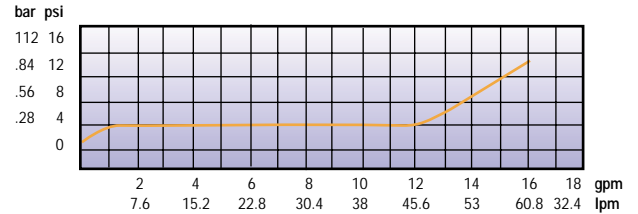
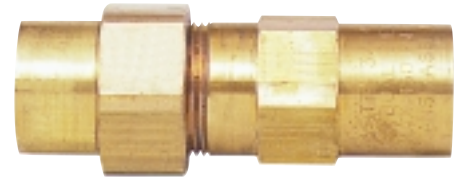

### MATERIALS

Machined brass construction, durable plastic check modules, injection molded of acetyl resin, silicone discs, Buna 'N' seals, and stainless steel springs.

### PRESSURE / TEMPERATURE

Maximum pressure: 150 psi (10 bars).

Minimum pressure: 10 psi (69 kPa).

Working temperature: 33°F to 140°F constant; intermittent to 180°F (0.6°C to 60°C sustained; intermittent to 82.2°C).

Maximum recommended flow: 15 gpm (57 lpm)

# SERIES 7/7C

## Dual Check Backflow Preventer For In-Line Continuous Pressure Applications

Size: 3/8" (10mm)

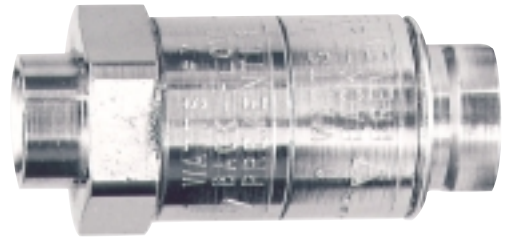

### DESCRIPTION

The Dual Check Series 7C is ideally suited for in-line continuous pressure applications such as wash-down sinks or other applications in which a hose-type device, connected to the domestic water supply, can be submerged in a non-potable liquid.

### STANDARDS



7C is tested and certified to meet ANSI/ASSE Standard 1024 for "Dual Check Valve Type Backflow Preventers." CSA Certified to Standard No. B64.6.

Important: Inquire with governing authorities for local installation requirements.

### SPECIFICATIONS

A dual check backflow preventer shall be installed at each wash sink hose unit or at referenced cross-connections to prevent the reverse flow of non-potable water into the potable domestic water system. These devices shall be chrome-plated brass consisting of two independently acting check valves, internally force-loaded to a normally closed position and designed and constructed to operate under intermittent or continuous pressure conditions. The backflow preventer shall be Watts Regulator Company's 3/8" (10mm) Series 7C. (Please select the model best suited to your application.)

### PRODUCT AVAILABILITIES

Series 7C: Inlet Connections - Types available, ordering code, sizes available.

Connection Type	Connection Code	Sizes Available	
		inches	mm
(U) National Pipe Thread Female	2	3/8	10

Series 7C: Outlet Connection - Types available, ordering code, sizes available.

National Pipe Thread Female	2	3/8	10
-----------------------------	---	-----	----

See "How to Order" on pages 10, 11.

Union (U) Connections available on all inlet/outlet types and sizes.

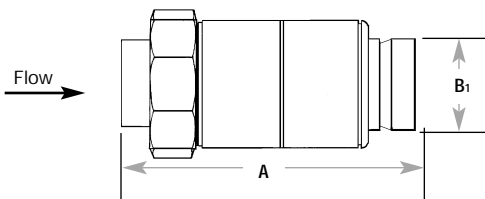

A		B <sub>1</sub>		Weight	
inches	mm	inches	mm	oz	gm
2 7/8	73	1 1/4	32	10	284

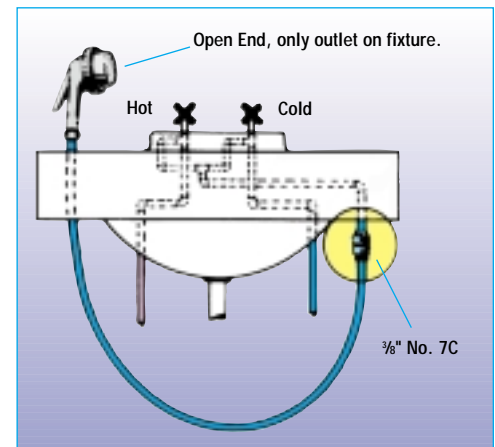
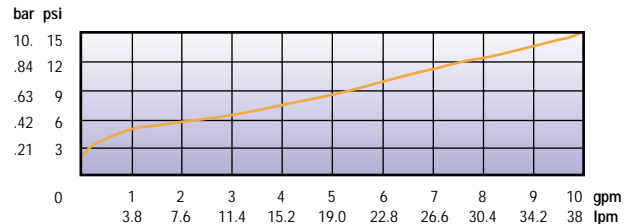

- ◆ 7 - Brass
- ◆ 7C - Brass with chrome nickel plate finish
- ◆ H7/H7C - With hose connection in brass or chrome nickel plate

### MATERIALS

Machined brass construction, chrome nickel plated body, EPR rubber check disc assemblies and Buna 'N' seals, stainless steel springs and pressure plates are standard.

### PRESSURE / TEMPERATURE

Maximum pressure: 150 psi (10 bars).

Minimum pressure: 10 psi (69 kPa).

Working temperature: 33°F to 140°F constant; intermittent to 180°F (0.6°C to 60° C sustained; intermittent to 82.2° C).

Maximum recommended flow: 15gpm (57lpm)



## Solving Thermal Expansion Problems.

By installing a backflow preventer on any residential water system, you create a closed system that won't accommodate thermal expansion. However, Watts offers several solutions to help you relieve excess pressure due to thermal expansion.



### Watts® Governor 80 Ball Cock & Relief Valve

A triple purpose product featuring a toilet tank ball cock fill valve, anti-siphon backflow preventer, and a thermal expansion relief valve.

The Governor 80 eliminates the need for expansion tanks, auxiliary relief valves, and their discharge lines by governing and limiting the pre-set static pressure in the domestic water system to 80 psi, as required by plumbing codes.

- ◆ Maximum operating temperature: 110°F (43°C).
- ◆ Standard heights: 10", 11½", 12½" (250, 292, 318mm).
- ◆ FDA Approved.
- ◆ ASSE 1002.

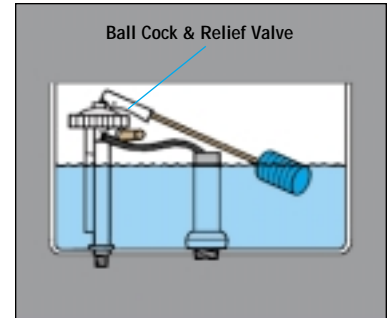

### Series DET Potable Water Expansion Tank For Domestic Hot Water Systems

An expansion tank designed to absorb the increased volume of water created when water in a storage tank is heated. By doing so, the DET keeps the system pressure below the relief setting of the Temperature and Pressure relief valve.

- ◆ Pre-pressurized steel tank with expansion membrane that prevents contact of water and air, ensuring long life for the system.
- ◆ Thermally-fused epoxy liner.
- ◆ In-line and free standing models available.
- ◆ Listed by IAPMO.
- ◆ Field-adjustable pre-charge.

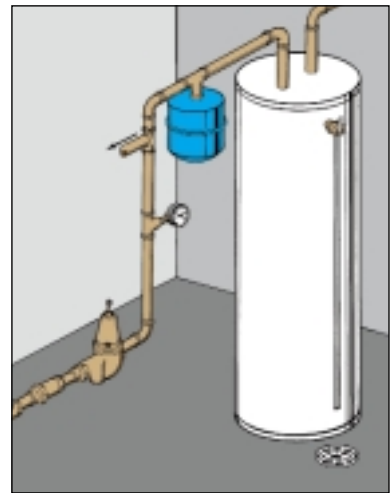

### Series 530 Pressure Relief Valve

Designed to effectively relieve pressure due only to thermal expansion in a closed system. Furnished without a lever.

- ◆ Adjustment Pressure Range: 50-175 psi (3 - 12 bars).

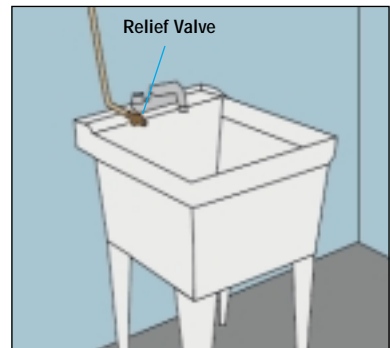

**IMPORTANT:** On all installations, inquire with governing authorities for local requirements.

# HOW TO ORDER

Watts Dual Check Backflow Preventers can be specified in many different combinations of connection types, sizes, and union options. See ordering example below.

Specify Series No.	Specify "U" if union inlet is desired	Specify inlet connection code	Specify "U" if union outlet is desired	Specify outlet connection code	Specify inlet connection size	Specify outlet connection size
7	U	2	-	U	3/4" (19mm)	X 3/4" (19mm)

## SERIES 7

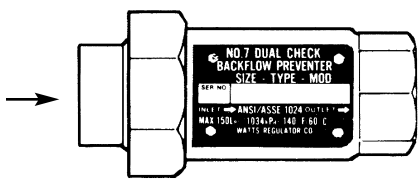

7U2-2 3/4" (19mm) x 3/4" (19mm) shown

\* When ordering Series 7 Valves with Meter Thread Connections, be sure to order connection size one size larger than meter thread. Examples:

Meter Size	Order
1/2" (13mm) and 5/8" (16mm)	3/4" (19mm)
5/8" (16mm) and 3/4" (19mm)	1" (25mm)
1" (25mm)	1 1/4" (32mm)

Series 7: Inlet/Outlet Connections – Types available, ordering code, sizes available.

Connection Type	Connection Code	Sizes Available	
		inches	mm
National Pipe Thread Female	2	1/2, 3/4, 1	13, 19, 25
National Pipe Thread Male	3	1/2, 3/4, 1, 1 1/4	13, 19, 25, 32
Meter Thread Female*	4	3/4, 1, 1 1/4	19, 25, 32
Meter Thread Male*	5	3/4, 1, 1 1/4	19, 25, 32
Pack Joint Female	6	3/4, 1	19, 25
Pack Joint Male	7	3/4, 1	19, 25
Female Solder	8	3/4, 1	19, 25
Male Sweat	9	3/4, 1	19, 25
Female Meter Thread (Swivel)	10	3/4, 1, 1 1/4	19, 25, 32
Male Hose Thread	11	3/4	19
Female Hose Thread	12	3/4	19
Male Meter Yoke Thread	13	3/4	19

Union (U) Connections available on all inlet/outlet types and sizes.

7 - - - - - " X "

## SERIES L7

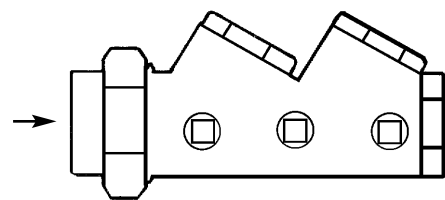

L7U2-2 1" (25mm) x 1" (25mm) shown

\* When ordering Series L7 Valves with Meter Thread Connections, be sure to order connection one size larger than meter thread. Examples:

Meter Size	Order
1/2" (13mm) and 5/8" (16mm)	3/4" (19mm)
5/8" (16mm) and 3/4" (19mm)	1" (25mm)
1" (25mm)	1 1/4" (32mm)

Series L7: Inlet Connections - Types available, ordering code, sizes available

Connection Type	Connection Code	Sizes Available	
		inches	mm
National Pipe Thread Female	2	3/4, 1	19, 25
National Pipe Thread Male	3	3/4, 1	19, 25
Meter Thread Female *	4	3/4, 1	19, 25
Meter Thread Male *	5	3/4, 1	19, 25
Pack Joint Female	6	3/4, 1	19, 25
Pack Joint Male	7	3/4, 1	19, 25
Female Solder	8	3/4, 1	19, 25
Male Solder	9	3/4, 1	19, 25
Female Meter Thread (Swivel)	10	3/4, 1	19, 25
Male Hose Thread	11	3/4, 1	19, 25
Female Hose Thread	12	3/4, 1	19, 25

Series L7: Outlet Connections - Types available, ordering code, sizes available

National Pipe Thread Female	2	3/4, 1	19, 25
Meter Thread Female	4	3/4, 1	19, 25
Female Hose Thread	12	3/4	19

Union (U) Connections available on all inlet/outlet types and sizes

L7 U - (N/A) " X "

**SERIES 07S**

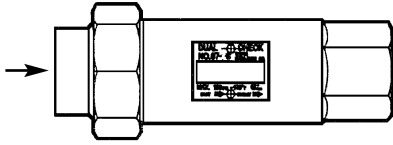

**07SU4-4**  
1" (25mm) x 1" (25mm) shown

Series 07S: Inlet Connections - Types available, ordering code, sizes available

Connection Type	Connection Code	Sizes Available	
		inches	mm
Meter Thread Female	4	1, 1 1/4	25, 32
National Pipe Thread Male	2	1, 1 1/4	25, 32

Series 07S: Outlet Connections - Types available, ordering code, sizes available

Meter Thread Male	5	1, 1 1/4	25, 32
National Pipe Thread Male	3	1, 1 1/4	

Union (U) Connections available on all inlet/outlet types and sizes

**07S** - **1 1/4" (32m) X 1 1/4" (32m)**

**SERIES CU7**

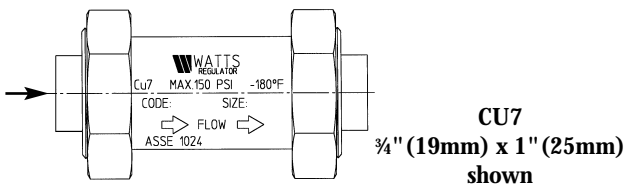

**CU7**  
3/4" (19mm) x 1" (25mm) shown

\* When ordering Series CU7 Valves with Meter Thread Connections, be sure to order connection one size larger than meter thread. Examples:

Meter Size	Order
1/2" (13mm) and 5/8" (16mm)	3/4" (19mm)
5/8" (16mm) and 3/4" (19mm)	1" (25mm)

Series CU7: Inlet/Outlet Connections - Types available, ordering code, sizes available

Connection Type	Connection Code	Sizes Available	
		inches	mm
National Pipe Thread Female	2	1/2", 3/4", 1"	13, 19, 25
National Pipe Thread Male	3	1/2", 3/4", 1"	13, 19, 25
Meter Thread Female*	4	3/4", 1"	19, 25
Meter Thread Male*	5	3/4", 1"	19, 25
Female Solder	8	3/4", 1"	19, 25
Female Meter Thread (Swivel)	10	3/4", 1"	19, 25

See "How to Order" on pages 10, 11.

**CU7 U** - **U** " **X** "

**MODEL 7B**

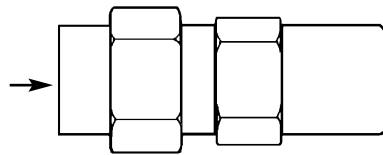

**7BU3-3**  
3/4" (19mm) x 3/4" (19mm) shown

Series 7B: Inlet Connections - Types available, ordering code, sizes available.

Connection Type	Connection Code	Sizes Available	
		inches	mm
(U) National Pipe Thread Female	2	3/4	19

Series 7B: Outlet Connection - Types available, ordering code, sizes available.

National Pipe Thread Female	2	3/4	19
-----------------------------	---	-----	----

Union (U) Connections available on all inlet/outlet types and sizes.

**7B U 2** - **2** **3/4" X 3/4" (19mm)**

**SERIES 7/7C**

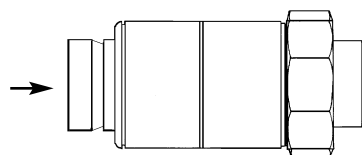

**7U2-2**  
3/8" (10mm) x 3/8" (10mm) with 3/4" (19mm) HT adapter shown

Series 7C: Inlet Connections - Types available, ordering code, sizes available.

Connection Type	Connection Code	Sizes Available	
		inches	mm
(U) National Pipe Thread Female	2	3/8	10

Series 7C: Outlet Connection - Types available, ordering code, sizes available.

National Pipe Thread Female	2	3/8	10
-----------------------------	---	-----	----

Union (U) Connections available on all inlet/outlet types and sizes.

Union Connections standard on inlet connection. 3/8" (10mm) No. H7 or H7C is supplied with 3/4" (19mm) H.T. adapters for 3/4" (19mm) H.T. female inlet and 3/4" (19mm) H.T. male outlet.

**7/7C** **2** - **2** **3/8" (10mm) X 3/8" (10mm)**

# THE BEST IN THE BUSINESS

## Commercial Products

Watts offers a diverse range of commercial products, including:

- ◆ Gate, Globe & Check Valves
- ◆ Flow Measurement & Balancing Valves
- ◆ Ball Valves
- ◆ Butterfly Valves
- ◆ Hot Water Extender Tempering Valves
- ◆ Strainers
- ◆ T&P Relief Valves
- ◆ Pressure Regulators
- ◆ Wall Hydrants
- ◆ Water Hammer Arrestors



## Backflow Preventers

Watts Regulator provides a wide variety of backflow preventers for residential and commercial uses, including:

- ◆ Reduced Pressure Zone
- ◆ Reduced Pressure Detector Assemblies
- ◆ Double Check Valves
- ◆ Double Check Detector Assemblies
- ◆ Dual Check Valve Backflow Preventers
- ◆ Intermediate Atmospheric Vent
- ◆ Atmospheric Vacuum Breakers
- ◆ Pressure Vacuum Breakers
- ◆ Hose Connection Vacuum Breaker
- ◆ Spill Resistant Vacuum Breaker
- ◆ Backflow Prevention Enclosures

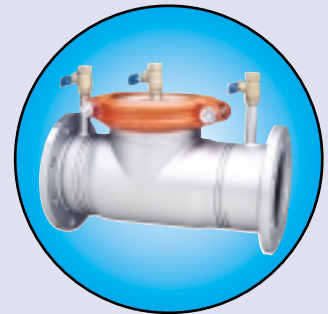

## Automatic Control Valves

Watts delivers a full family of automatic control valves, including:

- ◆ Pressure Reducing Valves
- ◆ Pressure Relief and Sustaining Valves
- ◆ Altitude Valves
- ◆ Rate of Flow Valves
- ◆ Flood Protection Valve
- ◆ Pump Control Valves
- ◆ Float Valves
- ◆ Solenoid Control Valves
- ◆ Check Valves

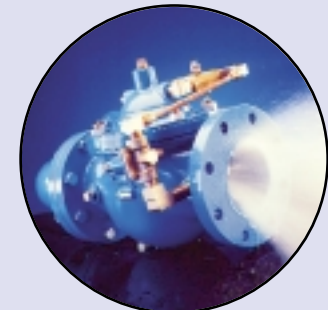

**For More Information Contact:**



USA: 815 Chestnut St., No. Andover, MA 01845-6098; [www.wattsreg.com](http://www.wattsreg.com)  
Canada: 5435 North Service Rd., Burlington, ONT. L7L 5H7; [www.wattscca.com](http://www.wattscca.com)

