

Installation, Operation and Maintenance

Model LFM110-18 / LFM6110-18

On-Off Float Control Valve with Pressure Sustaining Feature

Sizes: 1¼" to 24"

⚠ WARNING



Read this Manual **BEFORE** using this equipment. Failure to read and follow all safety and use information can result in death, serious personal injury, property damage, or damage to the equipment. Keep this Manual for future reference.



⚠ WARNING

Local building or plumbing codes may require modifications to the information provided. You are required to consult the local building and plumbing codes prior to installation. If the information provided here is not consistent with local building or plumbing codes, the local codes should be followed. This product must be installed by a licensed contractor in accordance with local codes and ordinances.

⚠ WARNING

Need for Periodic Inspection/Maintenance: This product must be tested periodically in compliance with local codes, but at least once per year or more as service conditions warrant. All products must be retested once maintenance has been performed. Corrosive water conditions and/or unauthorized adjustments or repair could render the product ineffective for the service intended. Regular checking and cleaning of the product's internal and external components helps assure maximum life and proper product function.

NOTICE

For Australia and New Zealand: Pipeline strainers should be installed between the upstream shutoff valve and the inlet of the backflow preventer.

It's important that this device be tested periodically in compliance with local codes, but at least once per year or more as service conditions warrant. If installed on a fire sprinkler system, all mechanical checks, such as alarm checks and backflow preventers, should be flow tested and inspected internally in accordance with NFPA 13 and NFPA 25.

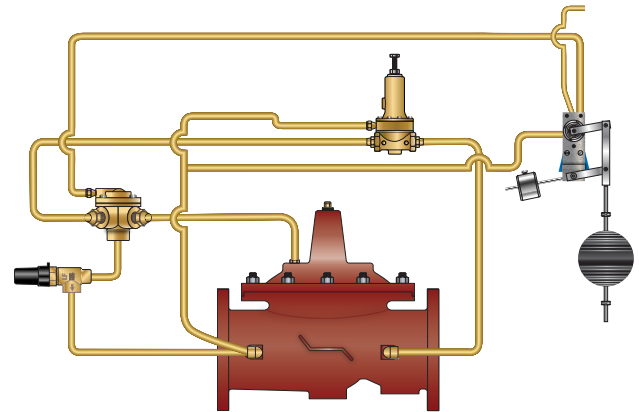

Table of Contents

Page

Introduction	2
Installation	2
Setting the Float Control Valve	3
Maintenance Schedule	6
Trouble Shooting Guide	6
Valve Disassembly Instructions	8
ACV Schematic	11

LFM110-18 (Globe) On-Off Float Control Valve with Pressure Sustaining Feature

Standard Components

- 1 – Main Valve (M100 – Single Chamber)
- 2 – Model 22 Accelerator Control
- 3 – On-Off Float Control
- 4A – High Level Adjustment Stop
- 4B – Low Level Adjustment Stop
- 5 – Adjustable Closing Speed
- 6 – Pressure Sustaining Control
- X – Isolation Cocks

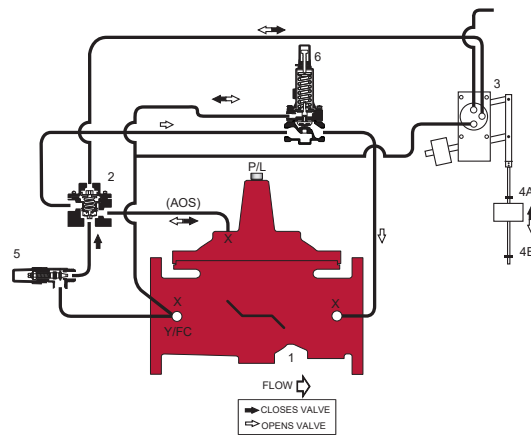

Operation

The On-Off Float Control Valve with Pressure Sustaining Feature is designed to open fully or close drip-tight as commanded by the Float Control Pilot. The Float Pilot may be either valve or remote mounted. The valve closes drip tight when water level reaches the adjustable high-level setpoint, and opens fully when water level is below the adjustable low-level setpoint, allowing a calculated “draw-down” of water level to increase tank circulation. The valve will also throttle to sustain a minimum upstream pressure during tank filling operations.

The On-Off Float Pilot directs upstream pressure into and out of the cover chamber of the 3-way Accelerator Pilot. When the cover of the Accelerator Pilot is pressurized, the main valve cover chamber is vented downstream, causing the valve to open. When the cover of the Accelerator Pilot is de-pressurized, the main valve cover chamber is connected to upstream pressure, causing the valve to close drip tight. Valve opening and closing speeds are separately adjustable. When water level reaches the adjustable high-level setpoint, the Float Pilot de-pressurizes the cover chamber of the 3-Way Accelerator, closing the valve drip tight.

The valve remains closed as water level decreases. When water level reaches the adjustable low-level setpoint, the Float Pilot pressurizes the cover chamber of the 3-Way Accelerator, opening the valve. High and low levels are separately adjustable by positioning stop collars on the float rod(s) at desired opening and closing setpoints.

The normally closed sustaining pilot remains open when upstream pressure is above the adjustable setpoint, and modulates toward a closed position if upstream pressure falls below the setpoint. As the sustaining pilot closes, fluid is directed into the main valve cover chamber, allowing the valve to modulate toward a closed position, raising upstream pressure. Normal on-off float control operation resumes when upstream pressure is above the sustaining pilot setpoint.

Installation

Start-up of an automatic control valve requires that proper procedures be followed. Time must be allowed for the valve to react to adjustments and the system to stabilize. The objective is to bring the valve into service in a controlled manner to protect the system from damaging over-pressure.

1. Prior to installation, flush line to remove debris.
2. Install valve so the flow arrow matches flow through the line, and gauges to monitor valve inlet and outlet pressures. A Position Indicator can be installed to provide visual indication of valve position and operation without disassembly.
3. Install isolation valves upstream and downstream of the main valve.
4. Provide adequate clearance for valve servicing and maintenance. Refer to valve servicing dimensions on next page. Avoid installing valves 6" and larger in the vertical position (main valve stem horizontal). Automatic Control Valves (ACVs) are designed for horizontal in-line installation, with the cover facing up (main valve stem vertical). Slow operation or premature stem and guide wear may occur if valve is not installed according to factory recommendations. Consult factory for detailed engineering review prior to ordering if valve is to be installed other than horizontally in-line.
5. If valve is equipped with a pilot control system, extra precautions should be made during installation to protect the piping circuit from damage. Only remove the pilot control system from the valve if necessary. Tubing and fittings should be kept clean and replaced exactly as removed. Consult appropriate hydraulic schematic to ensure proper re-assembly.
6. Install a pressure gauge at a location upstream of the valve.
7. Install float control onto tank and connect lines to valve per Watts Model F10-13 Specification Sheet.

Valve Servicing Dimensions



The following tables detail the recommended minimum valve servicing dimensions.

Globe

Size (in)	1¼	1½	2	2½	3	4	6	8	10	12	14	16	20	24
A (in)	16	16	20	22	22	24	32	34	38	44	48	52	56	56
B (in)	10	10	12	14	14	16	24	26	28	30	34	40	48	48

Angle

Size (in)	1¼	1½	2	2½	3	4	6	8	10	12	14	16
C (in)	16	16	20	22	22	24	32	34	38	44	48	52
D (in)	10	10	12	14	14	16	24	26	28	30	34	40

Setting the Float Control Valve

STEP 1

Pre-set pilots as noted:

Pressure Sustaining – Turn Sustaining Control adjustment screw OUT, counterclockwise, backing pressure off the spring, to allow it to stay open while adjusting the other controls

Opening and Closing Speed – Turn the adjustment screws on the Closing Speed and Opening Speed Controls, if the main valve is so equipped, OUT, counterclockwise, 1½ to 2½ turns from full closed position.

STEP 2

To ensure proper operation, any trapped air will need to be bled off the valve cover during startup. The ACV includes a bleed valve, use a flat head screwdriver to slowly open the valve (See Figure 1).

STEP 3

Pressure the line, by opening the upstream isolation valve slowly. Air is vented through the air bleed valve. Tighten the fitting when liquid begins to vent (See Figure 1).

STEP 4

Slowly open downstream isolation valve to establish flow through the system.



Figure 1
Position Indicator

Setting the Sustaining Control

STEP 5

Setting the Sustaining Control requires lowering the upstream pressure to the desired minimum sustained pressure.

STEP 6

Leave the downstream isolation valve fully open and close the upstream isolation valve until the inlet pressure drops to the desired setting.

STEP 7

Adjust the Sustaining Control screw IN, clockwise (See Figure 2A), until the inlet pressure begins to increase, or OUT, counterclockwise (See Figure 2B) to decrease, stopping at the desired pressure.

Clockwise to increase inlet pressure

Counterclockwise to decrease inlet pressure

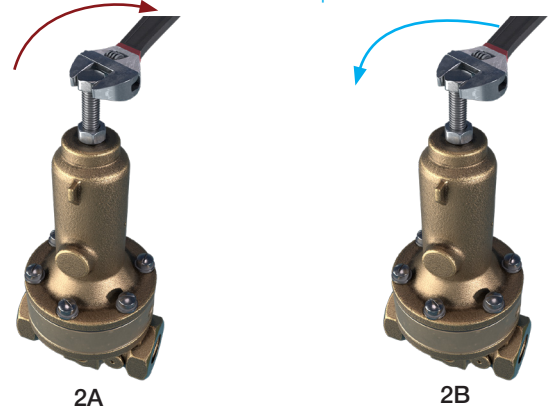

Figure 2
PV20C — Pressure Sustaining Control

STEP 8

Allow pressure to stabilize.

STEP 9

Fine-tune the sustaining setting as required as detailed in STEP 7.

STEP 10

Open Opening Speed Flow Control Adjustment: The Opening Speed Flow Control allows free flow into the cover and restricted flow out of the cover of the main valve.

If valve opening is too slow, turn the adjustment screw OUT, counterclockwise (See Figure 3B), increasing the rate of opening.

If valve opening is too quick, turn the adjustment screw IN, clockwise (See Figure 3A), decreasing the rate of opening.

Clockwise to DECREASE rate of opening

Counterclockwise to INCREASE the rate of opening

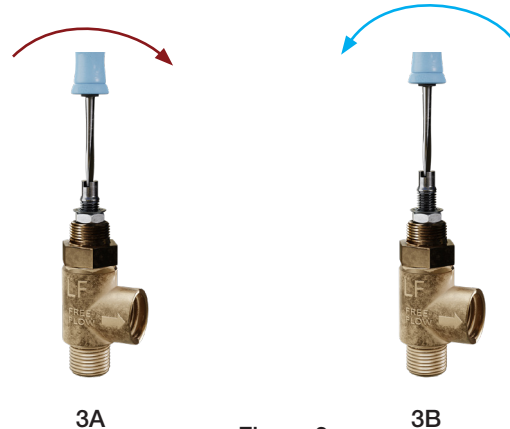

Figure 3
Flow Control

STEP 11

Closing Speed Needle Valve Adjustment: The closing speed needle valve regulates fluid pressure into the main valve cover chamber, controlling the valve closing speed. If valve closing is too slow, turn the adjustment screw OUT, counterclockwise, increasing the rate of closing.

STEP 12

Open upstream isolation valve to return to normal operation.

STEP 13

Manually operate the float linkage mechanism, allowing for the main valve to respond to the pilot.

STEP 14

Adjust Upper stop if main valve action allows the tank level to be higher than desired. When tank is full, valve starts closing (See Figure 4).

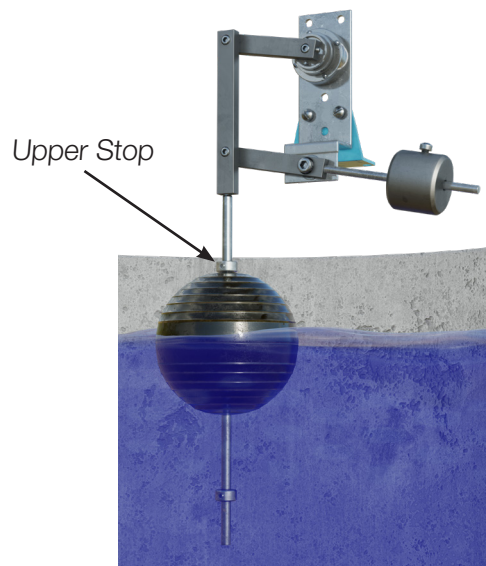

Figure 4
F10-13 - Float Control Pilot in Tank

Automatic Control Valve Maintenance Schedule

To ensure peak performance and longevity of your automatic control valve, Watts/Ames recommends following the below standard maintenance schedule.

- **Monthly Maintenance**
 - Visual inspection of valve(s) for leaks
 - Inspect for proper operation(s); exercise valve.
- **Quarterly Maintenance**
 - Conduct monthly inspection.
 - Validate/Re-establish necessary setpoints of controls/pilots.

- **Annual Maintenance**
 - Conduct monthly & quarterly inspections.
 - Inspect & clean all strainers.
 - Inspect valve coating, touch up as required.
- **3-5 Year Maintenance**
 - Conduct monthly, quarterly, & annual maintenance.
 - Inspect & replace valve elastomers (diaphragm, O-rings, valve/pilot seats)
 - Re-establish necessary set points of controls/pilots.

Troubleshooting Guide

⚠ WARNING

Warning: The valve cannot be serviced under pressure. Upstream and downstream Isolation Valves must be installed to protect system piping. Accurate diagnosis and troubleshooting requires the valve to open fully, and may subject downstream piping and equipment to high pressure and/or flow rates. The downstream Isolation Valve should be kept closed while diagnosing the valve.

Extreme caution should be used while performing the troubleshooting techniques listed below.

Recommended tools for diagnosis: (3) PRESSURE GAUGES, installed to monitor the inlet pressure, outlet pressure, and cover chamber pressure. If included, a POSITION INDICATOR should be installed to visually assess the position of the disc & diaphragm assembly.

Test 1: Diaphragm Seal Test

1. Close upstream & downstream isolation valves. Close pilot isolation valves or remove pilot control tubing to isolate valve cover from incoming fluid & pressure. Remove uppermost cover plug, test cock, or limit switch.
2. With the valve cover chamber vented to atmosphere, partially open the upstream isolation valve, allowing incoming pressure to lift the disc & diaphragm assembly. A volume of water will be displaced from the cover chamber as the valve opens; consult valve specification sheets for approximate cover capacity. A continuous flow of water from the open port indicates a damaged diaphragm or loose disc & diaphragm assembly. Disassemble valve and replace diaphragm or tighten disc & diaphragm assembly.

Test 2: Seat Seal Test

1. Close downstream isolation valve and install pressure gauges on an open inlet and outlet port of main valve.
2. Open upstream isolation valve to allow pressure on to the valve cover. Allow valve to fully close.
3. Monitor downstream pressure gauge; reading should hold steady below incoming pressure. If pressure on downstream side rises to match upstream pressure, leakage is occurring through the seat of the main valve. Disassemble valve, inspect and repair/replace any required parts.
 - a. If gauge pressure rises to match outlet pressure (downstream of closed isolation valve) yet remains below inlet pressure, the isolation valve may be leaking as opposed to main valve seat.

Test 3: Freedom of Movement/Valve Travel Test

1. Close upstream and downstream isolation valves. Install valve position indicator.
2. Partially open upstream isolation valve and allow cover to fill with fluid & pressure, closing the valve fully. Mark the position indicator's full closed position.
3. Isolate cover chamber from receiving fluid and pressure by closing isolation valves or removing control tubing.
4. Carefully vent cover chamber to atmosphere by opening test cock or removing a cover plug. Observe the valve position indicator as the valve travels to the full-open position. The disc & diaphragm assembly should move freely from fully closed to fully open position without binding or "grabbing" at any point during its movement.
 - a. The disc & diaphragm assembly may momentarily "hesitate" while travelling from fully closed to fully open position – this is a normal characteristic of diaphragm operated control valves, and does not indicate mechanical binding or improper valve operation.
 - b. A continuous discharge of water from the cover chamber after venting to atmosphere indicates leakage past the diaphragm.
5. If necessary, disassemble valve and inspect/repair disc & diaphragm assembly.

Troubleshooting Guide

Issue	Possible Cause	Corrective Action	Notes
Main Valve will not open	Closed isolation valves in pilot system.	Check isolation valves, ensure open.	
	Insufficient supply pressure.	Check upstream pressure.	Depending on water source, supply pressure may not be controlled by valve operator.
	Main valve stem assembly corroded/damaged	Inspect stem assembly, clean/replace if necessary.	
	Blockage in pilot system.	Inspect & clean any installed pilot system strainers, check orifice/speed controls for blockages.	
	Improperly configured opening speed control.	Adjust opening speed control to verify functionality, adjust as required.	Standard setting for opening speed control is 1 1/2 - 2 1/2 turns open from full closed position. Can be adjusted in field.
Main Valve will not close	Closed isolation valves in pilot system	Check isolation valves, ensure open.	
	Diaphragm is damaged	Conduct diaphragm seal test, repair and replace if necessary.	
	Main valve stem assembly corroded/damaged.	Inspect stem assembly, clean/replace if necessary.	
	Blockage in main valve.	Perform freedom of movement test; if valve does not close, disassemble and remove blockage.	
	Worn/damaged valve seat.	Perform seat sealing check; disassemble and inspect/repair seat if required.	
	Improperly configured closing speed control.	Adjust closing speed control to verify functionality, adjust as required.	Standard setting for closing speed control is 11/2 - 21/2 turns open from full closed position. Can be adjusted in field.

Valve Disassembly Instructions

Before undertaking valve disassembly, it is recommended to gather the following tools to aid you during the process:

- Small & large adjustable wrenches
- Screwdriver set
- Machinist fine metal file
- Fine wire brush
- Bench vise
- Basic valve IO&M manual
- Hammer & dull cold chisel
- Heavy-duty ratchet & socket set
- Hexagonal wrench set
- 320 grit/fine Emery cloth
- Appropriate technical bulletins for valve start-up procedures.

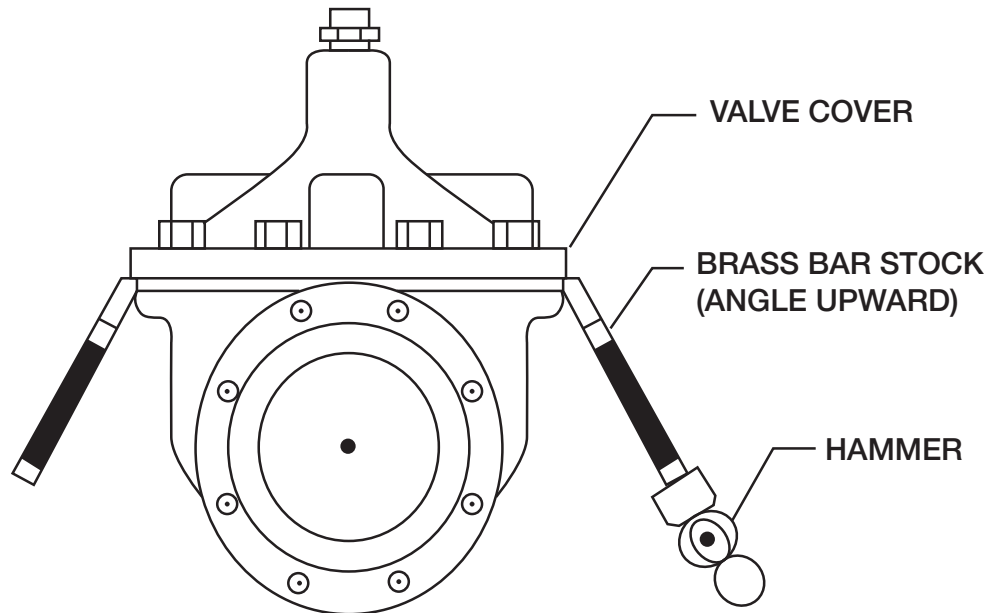

1. Isolate the valve from line pressure and depressurize it to ensure safe working conditions. Disconnect any electrical connections if so equipped.
2. Carefully remove Position Indicator or Limit Switches if equipped. Remove all tubing, fittings, and Control Pilots necessary to easily access and remove the cover. Remove cover nuts and washers.
3. Remove the cover. If cover is not free to be removed, loosen it by tapping upward along its outside edge with a dull cold chisel, pictured above.
 - a. Large valves may require the installation of lifting “eye” bolts in order to facilitate cover removal; installation ports are provided on the cover for this purpose.
4. Remove the Disc and Diaphragm Assembly from the valve body by lifting straight up.
 - a. Large diameter valves may require a lifting “eye” bolt to be installed in the valve stem accessory threads located on the very top of the valve stem.
5. Before removing Stem Nut, examine stem threads for mineral build-up. Remove deposits with a fine wire brush. Extreme care should be taken not to damage the finish on stem guiding surfaces when disassembling. Avoid applying pipe wrenches to top or bottom stem guide surfaces.

6. After removing the Stem Nut, the remainder of the Disc & Diaphragm Assembly should disassemble easily. Polish stem guide surfaces with fine emery cloth to remove any mineral deposits and inspect for excessive wear. Remove any mineral build-up from other components with wire brush or by using a Mineral Dissolving Solution. Inspect parts for wear and replace if necessary.
7. Inspect valve seat. If seat is not damaged, removal is not necessary. Valve seats 6" and smaller are threaded into the body of the valve and require a seat removal tool (Figure 5) (Table 1 details the tool dimensions for seat removal). Valve seats 8" and larger are held in the valve body with stainless steel cap screws. Remove seat retaining screws and lift seat straight up (Figure 6).

Table 1: Seat Removal Tool Dimension

Size	A	B	C	D	E (Dia.)	F
<i>in</i>	<i>Pipe Size (in)</i>	<i>Min. Length (in)</i>	<i>in</i>	<i>in</i>	<i>in</i>	<i>in</i>
1¼	1	3.12	0.38	0.25	0.44	0.55
1½	1	3.12	0.38	0.25	0.44	0.50
2	1¼	3.38	0.38	0.25	0.44	0.50
2½	2	4.0	0.38	0.38	0.56	0.62
3	2½	4.5	0.50	0.38	0.56	0.62
4	3	5.0	0.50	0.44	0.56	0.62
6	5	6.50	0.62	0.44	0.56	0.62

*Schedule 40 steel pipe

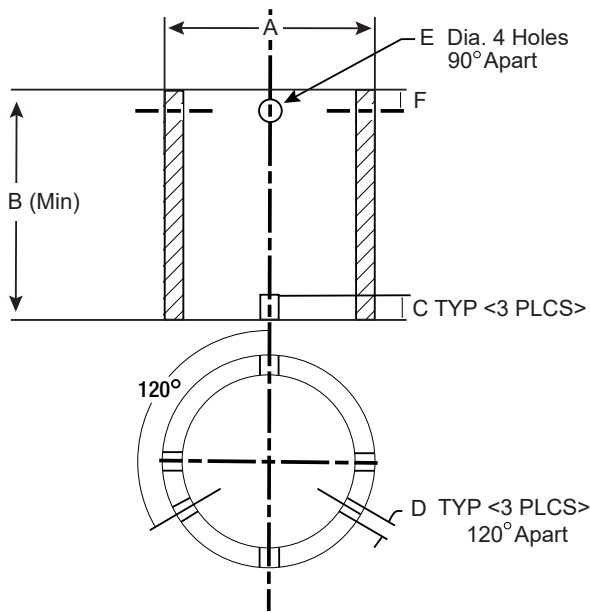

Figure 5

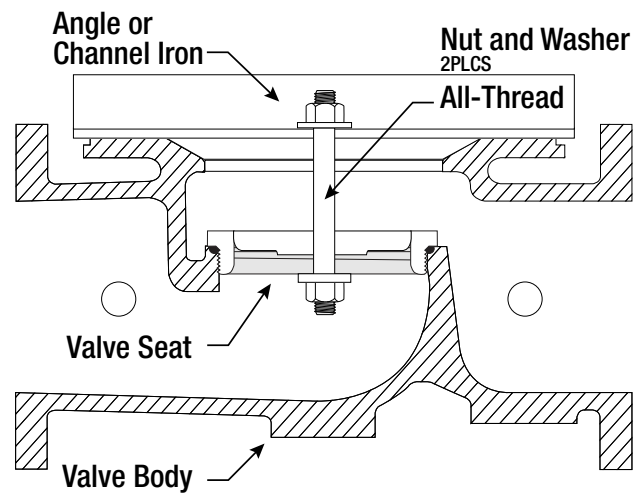

Figure 6

8. Replace Seat Disc, Diaphragm and Spacer Washers provided in Main Valve repair kit (refer to Table 2 or 3 for correct repair kit part number). Re-assemble in the reverse order of disassembly.

Table 2: Full Port Valve (M100/M1100) Repair Kits

Size (in)	1¼	1½	2	2½	3	4	6	8	10	12	14	16
P/N	0677-01	0677-01	0677-02	0677-03	0677-04	0677-05	0677-06	0677-07	0677-08	0677-09	0677-10	0677-11

Table 3: Reduced Port Valve (M6100 / M61100) Repair Kits

Size (in)	3	4	6	8	10	12	16	20 & 24
P/N	0677-02	0677-04	0677-05	0677-06	0677-07	0677-08	0677-09	0677-11

9. Re-Install Disc and Diaphragm Assembly in the valve, taking care not to damage the lower guide area in the center of the valve seat.
10. Re-install Cover Spring. Replace Valve Cover and tighten Cover Nuts in a crossing pattern to ensure even distribution. Test the Disc and Diaphragm Assembly for smooth travel by following the Freedom of Movement Test procedure in previous section.
11. Test the integrity of the Seat Seal by following the Seat Seal Test procedure in previous section.
12. Return valve to service by following instructions on the Technical Bulletin matching the valve function.

ACV Assembly Diagram – Series LFM110-18

NOTICE

Installation: If unit is installed in any orientation other than horizontal (cover up) OR extreme space constraints exist, consult customer service prior to or at the time of order.

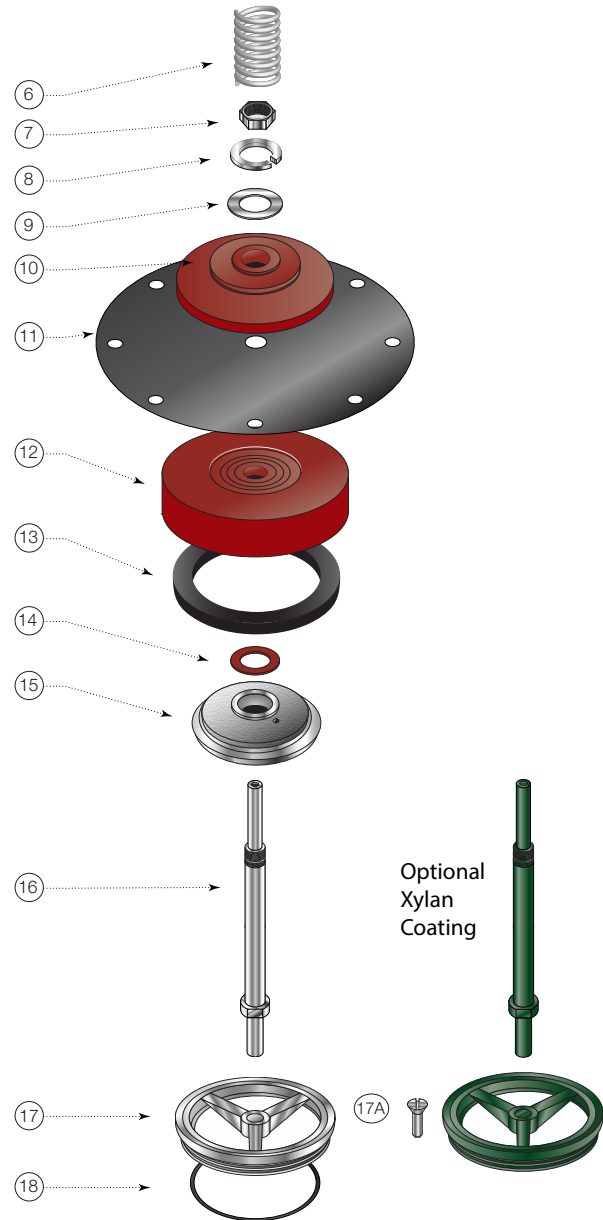
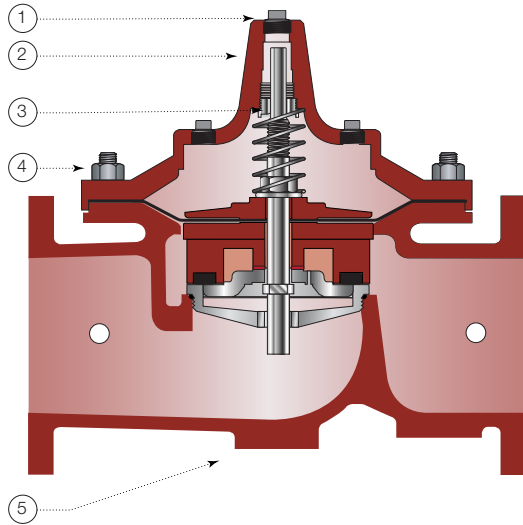

Item	Description	Material
1	Pipe Plug	Lead Free Brass
2	Cover	ASTM A536 65-45-12 Epoxy Coated Ductile Iron
3	Cover Bearing	ASTM A276 304 Stainless Steel
4	Stud with Cover Nut and Washer	ASTM A570 Gr.33 Zinc Plated Steel
5	Body	ASTM A536 65-45-12 Epoxy Coated Ductile Iron
6	Spring	ASTM A276 302 Stainless Steel
7	Stem Nut	ASTM A276 304 Stainless Steel
8	Lock Washer	ASTM A276 304 Stainless Steel
9	Stem Washer	ASTM A276 304 Stainless Steel
10	Diaphragm Washer	ASTM A536 65-45-12 Epoxy Coated Ductile Iron
11	Diaphragm*	Buna-N (Nitrile)
12	Disc Retainer	ASTM A536 65-45-12 Epoxy Coated Ductile Iron
13	Seat Disc*	Buna-N (Nitrile)
14	Spacer Washer* x5	NY300 Fiber*
15	Disc Guide	ASTM A743 CF8M (316) Stainless Steel
16	Shaft	ASTM A276 304 Stainless Steel
17	Seat Ring**	ASTM A743 CF8M (316) Stainless Steel
17A	Seat Screw** (8" and Larger)	ASTM A276 304 Stainless Steel
18	Seat Gasket*	Buna-N (Nitrile)

* Contained in Main Valve Repair Kit

**Note: 6 inch and Smaller Valves, Seat Ring is threaded

NOTES

Limited Warranty: Watts Regulator Co. (the "Company") warrants each product to be free from defects in material and workmanship under normal usage for a period of one year from the date of original shipment. In the event of such defects within the warranty period, the Company will, at its option, replace or recondition the product without charge.

THE WARRANTY SET FORTH HEREIN IS GIVEN EXPRESSLY AND IS THE ONLY WARRANTY GIVEN BY THE COMPANY WITH RESPECT TO THE PRODUCT. THE COMPANY MAKES NO OTHER WARRANTIES, EXPRESS OR IMPLIED. THE COMPANY HEREBY SPECIFICALLY DISCLAIMS ALL OTHER WARRANTIES, EXPRESS OR IMPLIED, INCLUDING BUT NOT LIMITED TO THE IMPLIED WARRANTIES OF MERCHANTABILITY AND FITNESS FOR A PARTICULAR PURPOSE.

The remedy described in the first paragraph of this warranty shall constitute the sole and exclusive remedy for breach of warranty, and the Company shall not be responsible for any incidental, special or consequential damages, including without limitation, lost profits or the cost of repairing or replacing other property which is damaged if this product does not work properly, other costs resulting from labor charges, delays, vandalism, negligence, fouling caused by foreign material, damage from adverse water conditions, chemical, or any other circumstances over which the Company has no control. This warranty shall be invalidated by any abuse, misuse, misapplication, improper installation or improper maintenance or alteration of the product.

Some States do not allow limitations on how long an implied warranty lasts, and some States do not allow the exclusion or limitation of incidental or consequential damages. Therefore the above limitations may not apply to you. This Limited Warranty gives you specific legal rights, and you may have other rights that vary from State to State. You should consult applicable state laws to determine your rights. **SO FAR AS IS CONSISTENT WITH APPLICABLE STATE LAW, ANY IMPLIED WARRANTIES THAT MAY NOT BE DISCLAIMED, INCLUDING THE IMPLIED WARRANTIES OF MERCHANTABILITY AND FITNESS FOR A PARTICULAR PURPOSE, ARE LIMITED IN DURATION TO ONE YEAR FROM THE DATE OF ORIGINAL SHIPMENT.**



USA: T: (978) 689-6066 • F: (978) 975-8350 • Watts.com
Canada: T: (888) 208-8927 • F: (905) 481-2316 • Watts.ca
Latin America: T: (52) 55-4122-0138 • Watts.com