

# Installation, Operation and Maintenance

## Model 986GD / 686GD

### Pump Control Control Valve

Sizes: 1 ¼" to 24"

#### ⚠ WARNING



Read this Manual **BEFORE** using this equipment. Failure to read and follow all safety and use information can result in death, serious personal injury, property damage, or damage to the equipment. Keep this Manual for future reference.



#### ⚠ WARNING

Local building or plumbing codes may require modifications to the information provided. You are required to consult the local building and plumbing codes prior to installation. If the information provided here is not consistent with local building or plumbing codes, the local codes should be followed. This product must be installed by a licensed contractor in accordance with local codes and ordinances.

#### ⚠ WARNING

**Need for Periodic Inspection/Maintenance:** This product must be tested periodically in compliance with local codes, but at least once per year or more as service conditions warrant. All products must be retested once maintenance has been performed. Corrosive water conditions and/or unauthorized adjustments or repair could render the product ineffective for the service intended. Regular checking and cleaning of the product's internal and external components helps assure maximum life and proper product function.

#### NOTICE

For Australia and New Zealand: Pipeline strainers should be installed between the upstream shutoff valve and the inlet of the backflow preventer.

It's important that this device be tested periodically in compliance with local codes, but at least once per year or more as service conditions warrant. If installed on a fire sprinkler system, all mechanical checks, such as alarm checks and backflow preventers, should be flow tested and inspected internally in accordance with NFPA 13 and NFPA 25.

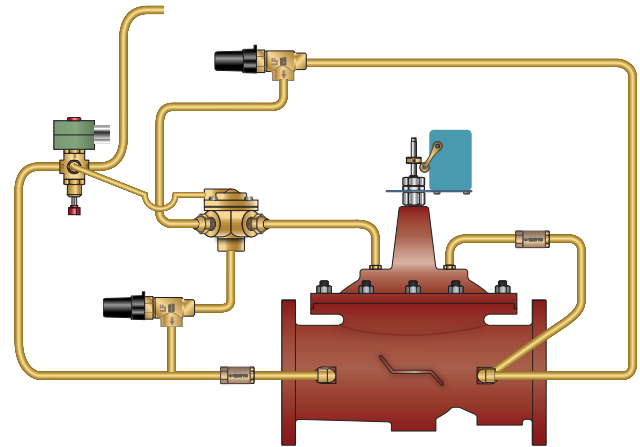

#### Table of Contents

#### Page

|  |    |
|--|----|
| Introduction . . . . .                         | 2  |
| Installation . . . . .                         | 2  |
| Commissioning the Pump Control Valve . . . . . | 3  |
| Maintenance Schedule . . . . .                 | 6  |
| Trouble Shooting Guide . . . . .               | 6  |
| Valve Disassembly Instructions . . . . .       | 8  |
| ACV Schematic . . . . .                        | 11 |

# 986GD (Globe) Pump Control Control Valve

## Standard Components

- 1 – Main Valve (905GD – Single Chamber)
- 2 – Model 22-1 Accelerator Control
- 3 – Limit Switch
- 4 – 3-Way Solenoid
- 5 – Check Valve
- 6 – Adjustable Closing Speed
- 7 – Adjustable Opening Speed
- Y – Y-Strainer
- X – Isolation Cocks

## Operation

The Pump Control Valve is designed to minimize the surges associated with the starting and stopping of pumps. The valve slowly opens and closes as required to control pumping related surges. The pump starts and stops against a closed valve.

**Pump Start Up:** When the pump is signaled to start, the 3-Way Solenoid is energized, directing pressure into the cover chamber of the 3-way Accelerator Pilot. The Accelerator Pilot allows the main valve cover chamber to be vented downstream, causing the valve to open at a controlled rate, gradually admitting pumping pressure into the distribution system. The rate of opening is controlled by the adjustable opening speed control, which restricts the speed of fluid and pressure evacuating the main valve cover chamber. The valve remains open during the pumping cycle.

**Pump Shutdown:** When the pump is signaled to turn off, the 3-Way Solenoid is de-energized, venting the cover chamber of the 3-way Accelerator Pilot. The Accelerator Pilot allows the main valve cover chamber to be connected to upstream pressure, causing the valve to close at a controlled rate. The valve slowly begins to close while the pump continues to operate. The closing rate of the valve is controlled by the adjustable closing speed control, which restricts the speed of fluid and pressure entering the main valve cover chamber. When the valve reaches the closed position, the limit switch is actuated, turning the pump off.

**Hydraulic Check Feature:** When the pump is turned off and downstream pressure is greater than upstream pressure, downstream pressure is admitted to the main valve cover chamber through a check valve in the pilot control system, closing the valve, preventing reversal of flow.

**Manual Operation:** Engaging the Solenoid Manual operator simulates power to the solenoid, manually opening the main valve. Disengaging the Solenoid Manual operator returns the valve to the closed position.

## Installation

Start-up of an automatic control valve requires that proper procedures be followed. Time must be allowed for the valve to react to adjustments and the system to stabilize. The objective is to bring the valve into service in a controlled manner to protect the system from damaging over-pressure.

1. Prior to installation, flush line to remove debris.
2. Install valve so the flow arrow matches flow through the line, and gauges to monitor valve inlet and outlet pressures.
3. Install isolation valves upstream and downstream of the main valve.
4. Provide adequate clearance for valve servicing and maintenance. Refer to valve servicing dimensions on next page. Avoid installing valves 6" and larger in the vertical position (main valve stem horizontal). Automatic Control Valves (ACVs) are designed for horizontal in-line installation, with the cover facing up (main valve stem vertical). Slow operation or premature stem and guide wear may occur if valve is not installed according to factory recommendations. Consult factory for detailed engineering review prior to ordering if valve is to be installed other than horizontally in-line.
5. If valve is equipped with a pilot control system, extra precautions should be made during installation to protect the piping circuit from damage. Only remove the pilot control system from the valve if necessary. Tubing and fittings should be kept clean and replaced exactly as removed. Consult appropriate hydraulic schematic to ensure proper re-assembly.
6. Connect solenoid wiring leads to desired switching device, using safe, standard electrical practices.
7. Wire the limit switch contacts to the proper relay connections, using safe, standard electrical practices. Adjust the limit switch collar to the approximate make/break contact position.
8. After installation, vent entrapped air from valve cover and pilot system by following instructions on Technical Bulletin.

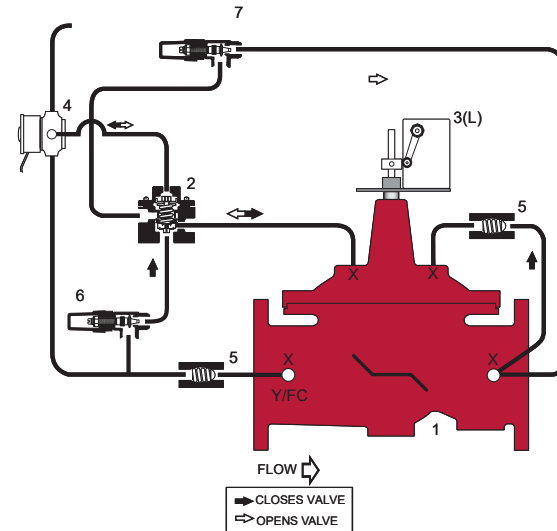

## Valve Servicing Dimensions

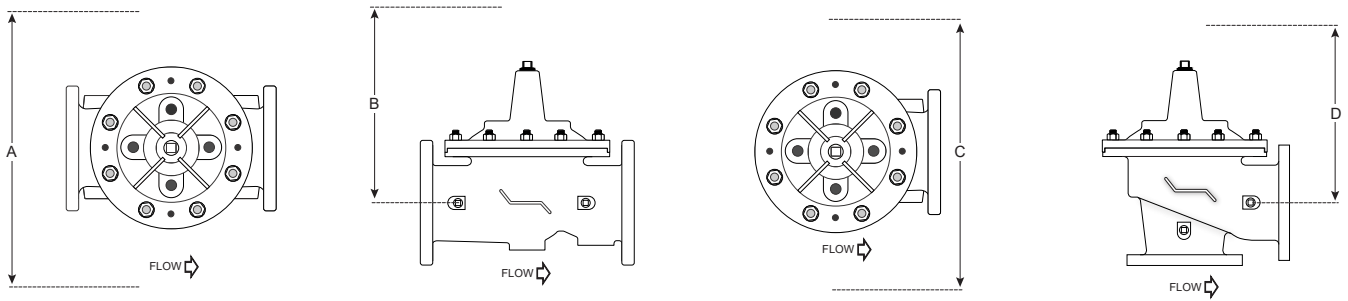

The following tables detail the recommended minimum valve servicing dimensions.

### Globe

| Size (in) | 1¼ | 1½ | 2  | 2½ | 3  | 4  | 6  | 8  | 10 | 12 | 14 | 16 | 20 | 24 |
|-----------|----|----|----|----|----|----|----|----|----|----|----|----|----|----|
| A (in)    | 16 | 16 | 20 | 22 | 22 | 24 | 32 | 34 | 38 | 44 | 48 | 52 | 56 | 56 |
| B (in)    | 10 | 10 | 12 | 14 | 14 | 16 | 24 | 26 | 28 | 30 | 34 | 40 | 48 | 48 |

### Angle

| Size (in) | 1¼ | 1½ | 2  | 2½ | 3  | 4  | 6  | 8  | 10 | 12 | 14 | 16 |
|-----------|----|----|----|----|----|----|----|----|----|----|----|----|
| C (in)    | 16 | 16 | 20 | 22 | 22 | 24 | 32 | 34 | 38 | 44 | 48 | 52 |
| D (in)    | 10 | 10 | 12 | 14 | 14 | 16 | 24 | 26 | 28 | 30 | 34 | 40 |

## Commissioning the Pump Control Valve

**NOTE:** System needs to be filled, pressurized, and ready for flow

### STEP 1

Pre-set pilots as noted:

**Opening and Closing Speed** – Turn the adjustment screws on the Closing Speed and Opening Speed Controls, if the main valve is so equipped, OUT, counterclockwise, 1½ to 2½ turns from full closed position.

**3-Way Solenoid Valve** – Turn manual operator stem counter-clockwise to full out position (See Figure 1).

### STEP 2

Energize the solenoid to check actuation and to confirm connection to power source.

### STEP 3

De-energize the solenoid prior to initial pump start.

### STEP 4

Loosen a tube fitting or cover plug at the main valve to allow air to vent during start-up.

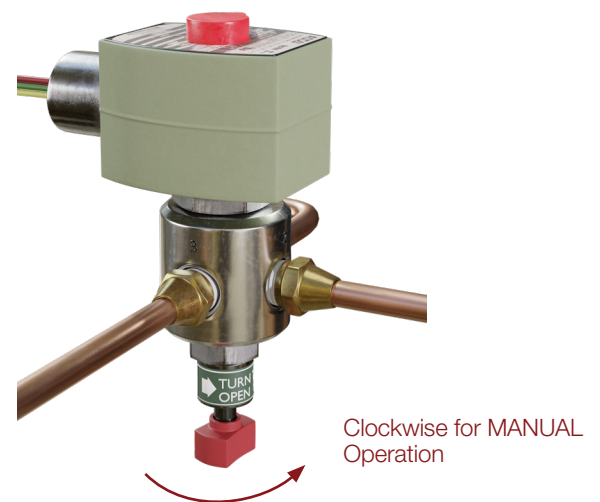

**Figure 1**  
**3-Way Solenoid**

## STEP 5

Energize the solenoid at pump start to open the main valve, checking that the main valve opens. Air is vented through the loosened fitting. Tighten the fitting when liquid begins to vent.

## STEP 6

Opening Speed Flow Control Adjustment: The Opening speed needle valve restricts flow into the cover and restricted flow out of the cover of the main valve.

If valve opening is too slow, turn the adjustment screw OUT, counterclockwise, increasing the rate of opening (See Figure 2B).

If valve opening is too quick, turn the adjustment screw IN, clockwise, decreasing the rate of opening (See Figure 2A).

## STEP 7

De-energize solenoid to check that the main valve closes.

## STEP 8

Closing Speed Needle Valve Adjustment: The closing speed

needle valve regulates fluid pressure into the main valve cover chamber, controlling the valve closing speed.

If valve closing is too slow, turn the adjustment screw OUT, counterclockwise, increasing the rate of closing.

## STEP 9

At valve closure booster pump will stop. Adjust limit switch collar to final position to ensure positive actuation of limit switch electrical contact, if necessary, by sliding up/down to location. (See Figure 3).

Clockwise to DECREASE  
rate of opening

Counterclockwise to INCREASE  
the rate of opening

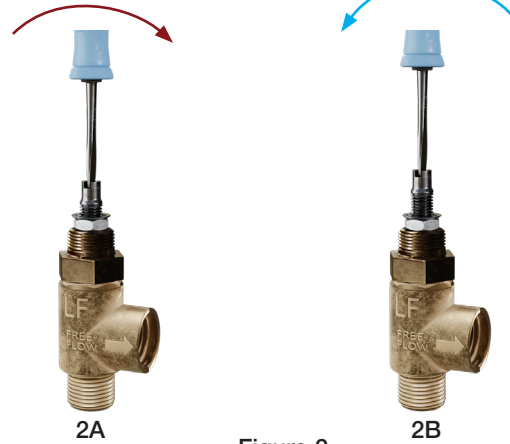

Figure 2  
Flow Control

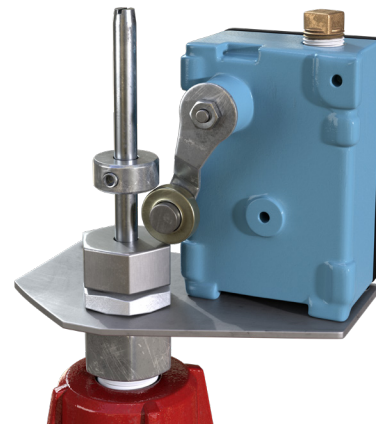

Figure 3  
Limit Switch in Closed Position

# Automatic Control Valve Maintenance Schedule

To ensure peak performance and longevity of your automatic control valve, Watts/Ames recommends following the below standard maintenance schedule.

- **Monthly Maintenance**
  - Visual inspection of valve(s) for leaks
  - Inspect for proper operation(s); exercise valve.
- **Quarterly Maintenance**
  - Conduct monthly inspection.
  - Validate/Re-establish necessary setpoints of controls/pilots.

- **Annual Maintenance**
  - Conduct monthly & quarterly inspections.
  - Inspect & clean all strainers.
  - Inspect valve coating, touch up as required.
- **3-5 Year Maintenance**
  - Conduct monthly, quarterly, & annual maintenance.
  - Inspect & replace valve elastomers (diaphragm, O-rings, valve/pilot seats)
  - Re-establish necessary set points of controls/pilots.

## Troubleshooting Guide

### ⚠ WARNING

**Warning:** The valve cannot be serviced under pressure. Upstream and downstream Isolation Valves must be installed to protect system piping. Accurate diagnosis and troubleshooting requires the valve to open fully, and may subject downstream piping and equipment to high pressure and/or flow rates. The downstream Isolation Valve should be kept closed while diagnosing the valve.

**Extreme caution should be used while performing the troubleshooting techniques listed below.**

Recommended tools for diagnosis: (3) PRESSURE GAUGES, installed to monitor the inlet pressure, outlet pressure, and cover chamber pressure. If included, a POSITION INDICATOR should be installed to visually assess the position of the disc & diaphragm assembly.

### Test 1: Diaphragm Seal Test

1. Close upstream & downstream isolation valves. Close pilot isolation valves or remove pilot control tubing to isolate valve cover from incoming fluid & pressure. Remove uppermost cover plug, test cock, or limit switch.
2. With the valve cover chamber vented to atmosphere, partially open the upstream isolation valve, allowing incoming pressure to lift the disc & diaphragm assembly. A volume of water will be displaced from the cover chamber as the valve opens; consult valve specification sheets for approximate cover capacity. A continuous flow of water from the open port indicates a damaged diaphragm or loose disc & diaphragm assembly. Disassemble valve and replace diaphragm or tighten disc & diaphragm assembly.

### Test 2: Seat Seal Test

1. Close downstream isolation valve and install pressure gauges on an open inlet and outlet port of main valve.
2. Open upstream isolation valve to allow pressure on to the valve cover. Allow valve to fully close.
3. Monitor downstream pressure gauge; reading should hold steady below incoming pressure. If pressure on downstream side rises to match upstream pressure, leakage is occurring through the seat of the main valve. Disassemble valve, inspect and repair/replace any required parts.
  - a. If gauge pressure rises to match outlet pressure (downstream of closed isolation valve) yet remains below inlet pressure, the isolation valve may be leaking as opposed to main valve seat.

### Test 3: Freedom of Movement/Valve Travel Test

1. Close upstream and downstream isolation valves. Install valve position indicator.
2. Partially open upstream isolation valve and allow cover to fill with fluid & pressure, closing the valve fully. Mark the position indicator's full closed position.
3. Isolate cover chamber from receiving fluid and pressure by closing isolation valves or removing control tubing.
4. Carefully vent cover chamber to atmosphere by opening test cock or removing a cover plug. Observe the valve position indicator as the valve travels to the full-open position. The disc & diaphragm assembly should move freely from fully closed to fully open position without binding or "grabbing" at any point during its movement.
  - a. The disc & diaphragm assembly may momentarily "hesitate" while travelling from fully closed to fully open position – this is a normal characteristic of diaphragm operated control valves, and does not indicate mechanical binding or improper valve operation.
  - b. A continuous discharge of water from the cover chamber after venting to atmosphere indicates leakage past the diaphragm.
5. If necessary, disassemble valve and inspect/repair disc & diaphragm assembly.

# Troubleshooting Guide

| Issue                            | Possible Cause                               | Corrective Action   | Notes   |
|----------------------------------|--|---|---|
| <b>Main Valve will not open</b>  | Closed isolation valves in pilot system.     | Check isolation valves, ensure open.  |   |
|                                  | Insufficient supply pressure.                | Check upstream pressure.  | Depending on water source, supply pressure may not be controlled by valve operator.   |
|                                  | Main valve stem assembly corroded/damaged    | Inspect stem assembly, clean/replace if necessary.  |   |
|                                  | Blockage in pilot system.                    | Inspect & clean any installed pilot system strainers, check orifice/speed controls for blockages.             |   |
|                                  | Improperly configured opening speed control. | Adjust opening speed control to verify functionality, adjust as required.                                     | Standard setting for opening speed control is 1 1/2 - 2 1/2 turns open from full closed position. Can be adjusted in field. |
| <b>Main Valve will not close</b> | Closed isolation valves in pilot system      | Check isolation valves, ensure open.  |   |
|                                  | Diaphragm is damaged                         | Conduct diaphragm seal test, repair and replace if necessary.   |   |
|                                  | Main valve stem assembly corroded/damaged.   | Inspect stem assembly, clean/replace if necessary.  |   |
|                                  | Blockage in main valve.                      | Perform freedom of movement test; if valve does not close, disassemble and remove blockage.                   |   |
|                                  | Worn/damaged valve seat.                     | Perform seat sealing check; disassemble and inspect/repair seat if required.                                  |   |
|                                  | Improperly configured closing speed control. | Adjust closing speed control to verify functionality, adjust as required.                                     | Standard setting for closing speed control is 1 1/2 - 2 1/2 turns open from full closed position. Can be adjusted in field. |
| <b>Solenoid will not actuate</b> | Possible Cause: Low or no voltage            | Check voltage at the solenoid connection, insuring that it has the minimum of 85% of the coils rated voltage. | Should be performed by licensed electrician   |
|                                  | Manual operated is engaged                   | Turn manual operator counter-clockwise to disengage   |   |

# Valve Disassembly Instructions

Before undertaking valve disassembly, it is recommended to gather the following tools to aid you during the process:

- Small & large adjustable wrenches
- Screwdriver set
- Machinist fine metal file
- Fine wire brush
- Bench vise
- Basic valve IO&M manual
- Hammer & dull cold chisel
- Heavy-duty ratchet & socket set
- Hexagonal wrench set
- 320 grit/fine Emery cloth
- Appropriate technical bulletins for valve start-up procedures.

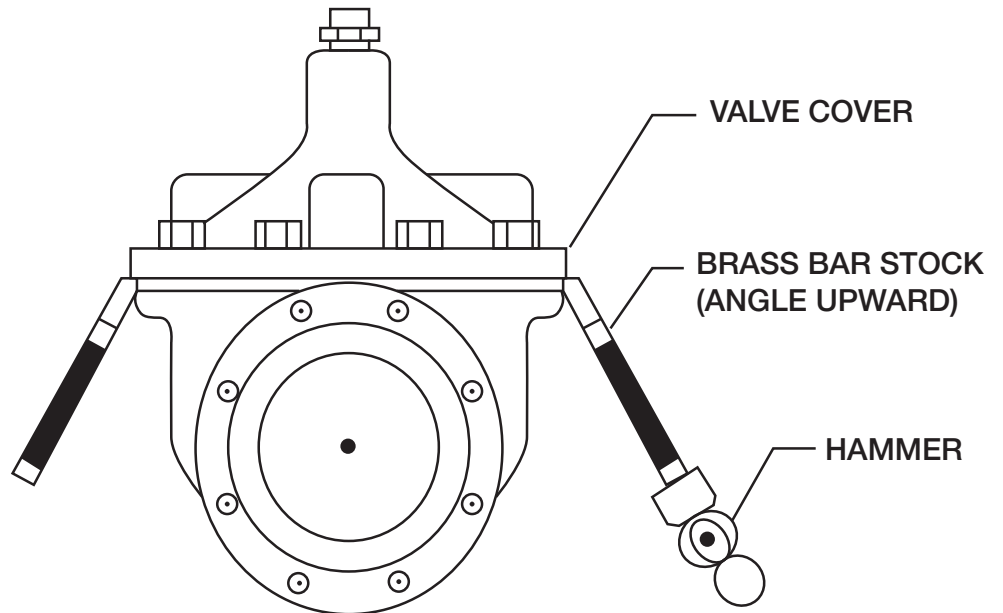

1. Isolate the valve from line pressure and depressurize it to ensure safe working conditions. Disconnect any electrical connections if so equipped.
2. Carefully remove Position Indicator or Limit Switches if equipped. Remove all tubing, fittings, and Control Pilots necessary to easily access and remove the cover. Remove cover nuts and washers.
3. Remove the cover. If cover is not free to be removed, loosen it by tapping upward along its outside edge with a dull cold chisel, pictured above.
  - a. Large valves may require the installation of lifting “eye” bolts in order to facilitate cover removal; installation ports are provided on the cover for this purpose.
4. Remove the Disc and Diaphragm Assembly from the valve body by lifting straight up.
  - a. Large diameter valves may require a lifting “eye” bolt to be installed in the valve stem accessory threads located on the very top of the valve stem.
5. Before removing Stem Nut, examine stem threads for mineral build-up. Remove deposits with a fine wire brush. Extreme care should be taken not to damage the finish on stem guiding surfaces when disassembling. Avoid applying pipe wrenches to top or bottom stem guide surfaces.

6. After removing the Stem Nut, the remainder of the Disc & Diaphragm Assembly should disassemble easily. Polish stem guide surfaces with fine emery cloth to remove any mineral deposits and inspect for excessive wear. Remove any mineral build-up from other components with wire brush or by using a Mineral Dissolving Solution. Inspect parts for wear and replace if necessary.
7. Inspect valve seat. If seat is not damaged, removal is not necessary. Valve seats 6" and smaller are threaded into the body of the valve and require a seat removal tool (Figure 2) (Table 1 details the tool dimensions for seat removal). Valve seats 8" and larger are held in the valve body with stainless steel cap screws. Remove seat retaining screws and lift seat straight up (Figure 3).

**Table 1: Seat Removal Tool Dimension**

| Size      | A                     | B                       | C         | D         | E (Dia.)  | F         |
|-----------|-----------------------|-------------------------|-----------|-----------|-----------|-----------|
| <i>in</i> | <i>Pipe Size (in)</i> | <i>Min. Length (in)</i> | <i>in</i> | <i>in</i> | <i>in</i> | <i>in</i> |
| 1¼        | 1                     | 3.12                    | 0.38      | 0.25      | 0.44      | 0.55      |
| 1½        | 1                     | 3.12                    | 0.38      | 0.25      | 0.44      | 0.50      |
| 2         | 1¼                    | 3.38                    | 0.38      | 0.25      | 0.44      | 0.50      |
| 2½        | 2                     | 4.0                     | 0.38      | 0.38      | 0.56      | 0.62      |
| 3         | 2½                    | 4.5                     | 0.50      | 0.38      | 0.56      | 0.62      |
| 4         | 3                     | 5.0                     | 0.50      | 0.44      | 0.56      | 0.62      |
| 6         | 5                     | 6.50                    | 0.62      | 0.44      | 0.56      | 0.62      |

\*Schedule 40 steel pipe

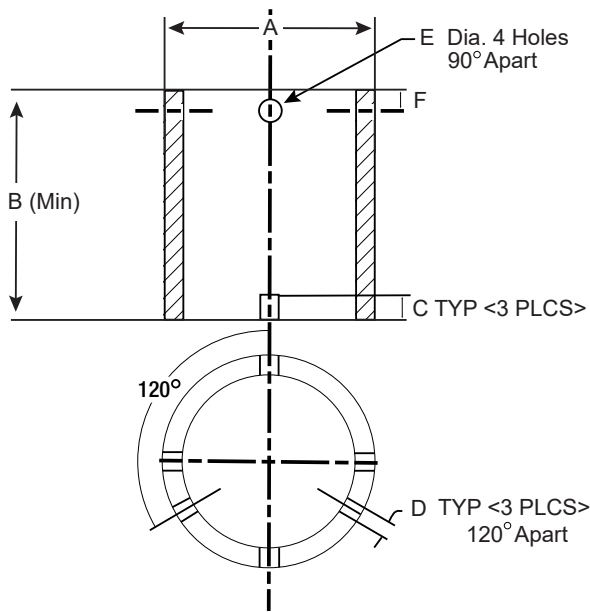

**Figure 2**

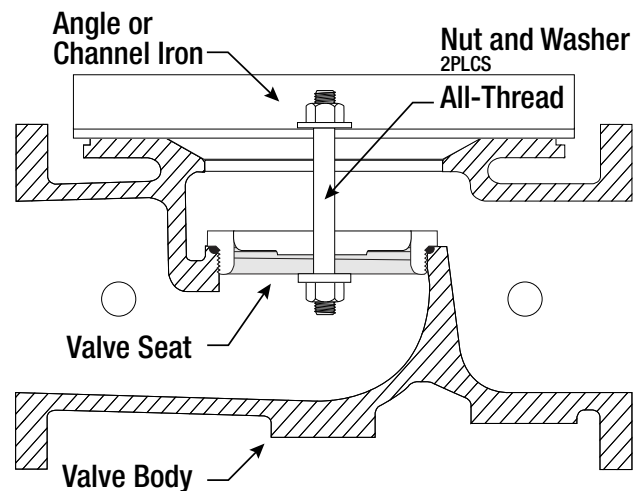

**Figure 3**



8. Replace Seat Disc, Diaphragm and Spacer Washers provided in Main Valve repair kit (refer to Table 2 or 3 for correct repair kit part number). Re-assemble in the reverse order of disassembly.

**Table 2: Full Port Valve (905GD/905AD) Repair Kits**

| Size (in) | 1¼      | 1½      | 2       | 2½      | 3       | 4       | 6       | 8       | 10      | 12      | 14      | 16      |
|-----------|---------|---------|---------|---------|---------|---------|---------|---------|---------|---------|---------|---------|
| P/N       | 0677-01 | 0677-01 | 0677-02 | 0677-03 | 0677-04 | 0677-05 | 0677-06 | 0677-07 | 0677-08 | 0677-09 | 0677-10 | 0677-11 |

**Table 3: Reduced Port Valve (605GD/605AD) Repair Kits**

| Size (in) | 3       | 4       | 6       | 8       | 10      | 12      | 16      | 20 & 24 |
|-----------|---------|---------|---------|---------|---------|---------|---------|---------|
| P/N       | 0677-02 | 0677-04 | 0677-05 | 0677-06 | 0677-07 | 0677-08 | 0677-09 | 0677-11 |

9. Re-Install Disc and Diaphragm Assembly in the valve, taking care not to damage the lower guide area in the center of the valve seat.
10. Re-install Cover Spring. Replace Valve Cover and tighten Cover Nuts in a crossing pattern to ensure even distribution. Test the Disc and Diaphragm Assembly for smooth travel by following the Freedom of Movement Test procedure in previous section.
11. Test the integrity of the Seat Seal by following the Seat Seal Test procedure in previous section.
12. Return valve to service by following instructions on the Technical Bulletin matching the valve function.

# ACV Assembly Diagram – Series 986GD

## NOTICE

Installation: If unit is installed in any orientation other than horizontal (cover up) OR extreme space constraints exist, consult customer service prior to or at the time of order.

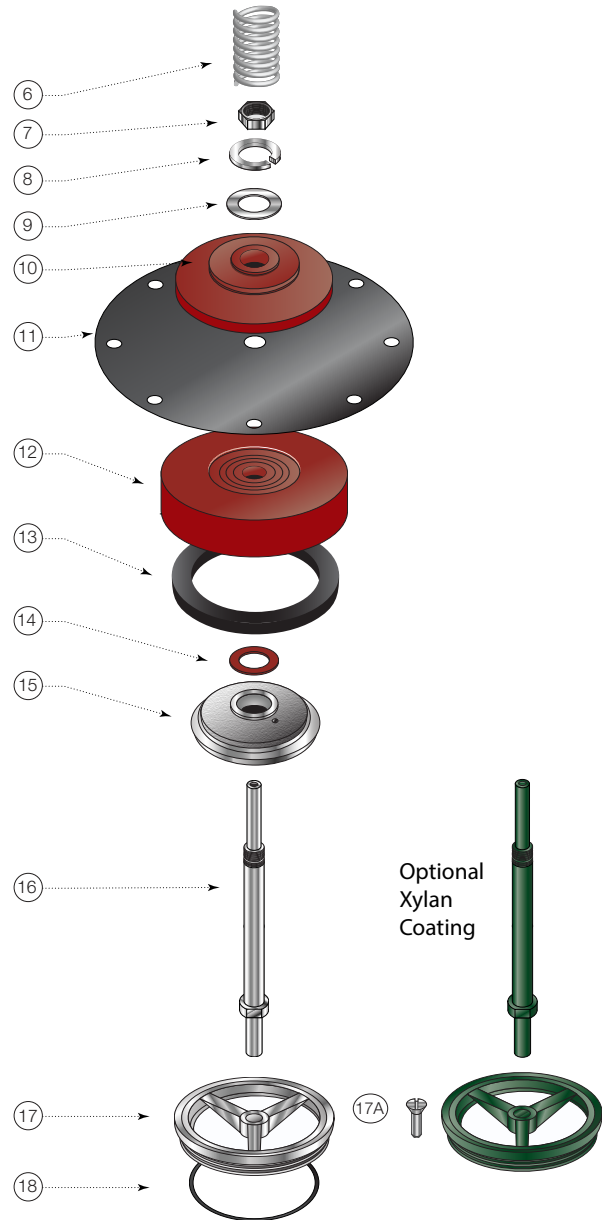
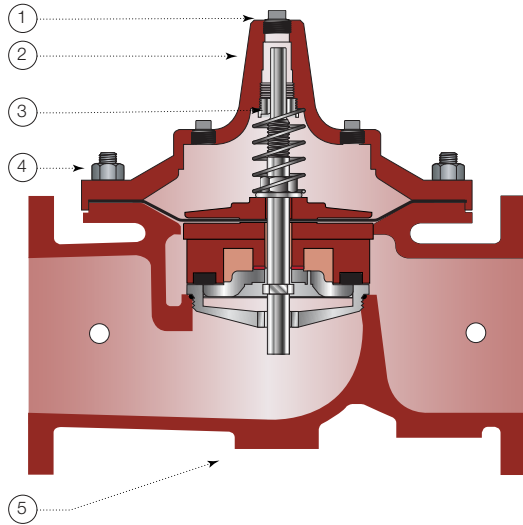

| Item | Description                    | Material                                     |
|------|--------------------------------|--|
| 1    | Pipe Plug                      | Lead Free Brass                              |
| 2    | Cover                          | ASTM A536 65-45-12 Epoxy Coated Ductile Iron |
| 3    | Cover Bearing                  | ASTM A276 304 Stainless Steel                |
| 4    | Stud with Cover Nut and Washer | ASTM A570 Gr.33 Zinc Plated Steel            |
| 5    | Body                           | ASTM A536 65-45-12 Epoxy Coated Ductile Iron |
| 6    | Spring                         | ASTM A276 302 Stainless Steel                |
| 7    | Stem Nut                       | ASTM A276 304 Stainless Steel                |
| 8    | Lock Washer                    | ASTM A276 304 Stainless Steel                |
| 9    | Stem Washer                    | ASTM A276 304 Stainless Steel                |
| 10   | Diaphragm Washer               | ASTM A536 65-45-12 Epoxy Coated Ductile Iron |
| 11   | Diaphragm*                     | Buna-N (Nitrile)                             |
| 12   | Disc Retainer                  | ASTM A536 65-45-12 Epoxy Coated Ductile Iron |
| 13   | Seat Disc*                     | Buna-N (Nitrile)                             |
| 14   | Spacer Washer* x5              | NY300 Fiber*                                 |
| 15   | Disc Guide                     | ASTM A743 CF8M (316) Stainless Steel         |
| 16   | Shaft                          | ASTM A276 304 Stainless Steel                |
| 17   | Seat Ring**                    | ASTM A743 CF8M (316) Stainless Steel         |
| 17A  | Seat Screw** (8" and Larger)   | ASTM A276 304 Stainless Steel                |
| 18   | Seat Gasket*                   | Buna-N (Nitrile)                             |

\* Contained in Main Valve Repair Kit

\*\*Note: 6 inch and Smaller Valves, Seat Ring is threaded

Optional  
Xylan  
Coating

# ***NOTES***



**A WATTS Brand**

---

**USA: Backflow** T: (978) 689-6066 • F: (978) 975-8350 • [AmesFireWater.com](http://AmesFireWater.com)  
**USA: Control Valves** T: (713) 943-0688 • F: (713) 944-9445 • [AmesFireWater.com](http://AmesFireWater.com)  
**Canada:** T: (888) 208-8927 • F: (905) 481-2316 • [AmesFireWater.ca](http://AmesFireWater.ca)  
**Latin America:** T: (52) 55-4122-0138 • [AmesFireWater.com](http://AmesFireWater.com)