

Installation, Operation and Maintenance

Model LFM513-5 / LFM6513-5

Pump Control Control Valve with Mechanical Check Feature

Sizes: 2" to 24"

⚠ WARNING



Read this Manual **BEFORE** using this equipment. Failure to read and follow all safety and use information can result in death, serious personal injury, property damage, or damage to the equipment. Keep this Manual for future reference.

THINK SAFETY FIRST

⚠ WARNING

Local building or plumbing codes may require modifications to the information provided. You are required to consult the local building and plumbing codes prior to installation. If the information provided here is not consistent with local building or plumbing codes, the local codes should be followed. This product must be installed by a licensed contractor in accordance with local codes and ordinances.

⚠ WARNING

Need for Periodic Inspection/Maintenance: This product must be tested periodically in compliance with local codes, but at least once per year or more as service conditions warrant. All products must be retested once maintenance has been performed. Corrosive water conditions and/or unauthorized adjustments or repair could render the product ineffective for the service intended. Regular checking and cleaning of the product's internal and external components helps assure maximum life and proper product function.

NOTICE

For Australia and New Zealand: Pipeline strainers should be installed between the upstream shutoff valve and the inlet of the backflow preventer.

It's important that this device be tested periodically in compliance with local codes, but at least once per year or more as service conditions warrant. If installed on a fire sprinkler system, all mechanical checks, such as alarm checks and backflow preventers, should be flow tested and inspected internally in accordance with NFPA 13 and NFPA 25.

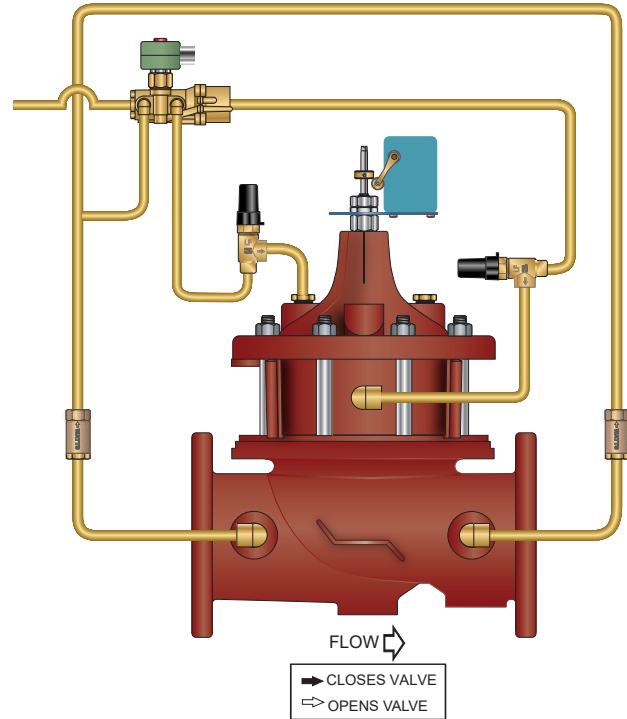

Table of Contents	Page
Introduction	2
Installation	2
Commissioning the Pump Control Valve	3
Maintenance Schedule	6
Trouble Shooting Guide	6
Valve Disassembly Instructions	8
ACV Schematic	11

LFM513-5 (Globe) Pump Control Control Valve with Mechanical Check Feature

Standard Components

- 1 – Main Valve (M518 - Dual Chamber with Lift-Check)
- 2 – 4-Way Solenoid
- 3 – Check Valve
- 4 – Limit Switch
- 5 – Adjustable Opening Speed
- 6 – Adjustable Closing Speed
- Y – Y-Strainer
- X – Isolation Cocks

Operation

The Pump Control Valve is designed to minimize the surges associated with the starting and stopping of pumps. The valve slowly opens and closes as required to control pumping related surges. The pump starts and stops against a closed valve.

Pump start up: When the pump is signaled to start, the 4-Way Solenoid is energized and directs fluid and pressure into the power chamber (below the diaphragm), and relieves fluid and pressure from the cover chamber (above the diaphragm). The fluid and pressure relieved from the cover chamber is vented to atmosphere or available floor drain. The valve opens at an adjustable rate, gradually admitting pumping pressure into the distribution system. Rate of valve opening is controlled by the adjustable opening speed control, which restricts the speed at which fluid and pressure evacuate the cover chamber. The valve remains fully open during the pumping cycle.

Pump shutdown: When the pump is signaled to shut-off, the 4-Way Solenoid is de-energized, and directs fluid and pressure into the cover chamber (above the diaphragm), and relieves fluid and pressure from the power chamber (below the diaphragm). The fluid and pressure relieved from the power chamber is vented to atmosphere or available floor drain. The valve closes at an adjustable rate, gradually reducing pumping pressure. Rate of valve closure is controlled by the adjustable closing speed control, which restricts the speed at which fluid and pressure evacuate the power chamber. When the valve reaches the closed position, the limit switch is actuated, turning the pump off.

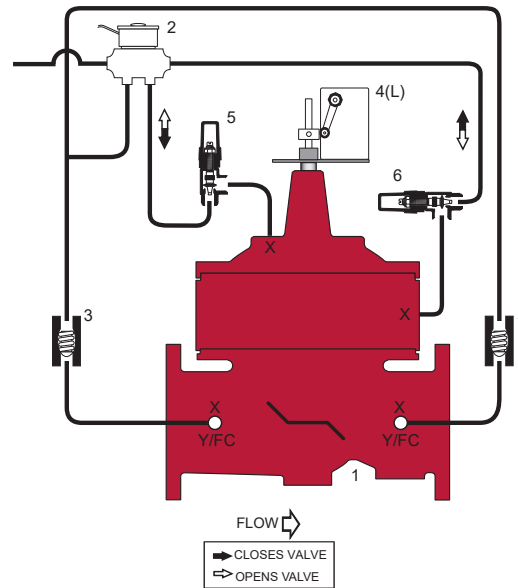

Emergency Closure: The valve is equipped with a Mechanical Check Feature, which acts independent of diaphragm position, and provides immediate closure when flow ceases.

Manual Operation: Engaging the Solenoid Manual operator simulates power to the solenoid, manually opening the main valve. Disengaging the Solenoid Manual operator returns the valve to the closed position.

Installation

Start-up of an automatic control valve requires that proper procedures be followed. Time must be allowed for the valve to react to adjustments and the system to stabilize. The objective is to bring the valve into service in a controlled manner to protect the system from damaging over-pressure.

1. Prior to installation, flush line to remove debris.
2. Install valve so the flow arrow matches flow through the line, and gauges to monitor valve inlet and outlet pressures.
3. Install isolation valves upstream and downstream of the main valve.
4. Provide adequate clearance for valve servicing and maintenance. Refer to valve servicing dimensions on next page. Avoid installing valves 6" and larger in the vertical position (main valve stem horizontal). Automatic Control Valves (ACVs) are designed for horizontal in-line installation, with the cover facing up (main valve stem vertical). Slow operation or premature stem and guide wear may occur if valve is not installed according to factory recommendations. Consult factory for detailed engineering review prior to ordering if valve is to be installed other than horizontally in-line.
5. If valve is equipped with a pilot control system, extra precautions should be made during installation to protect the piping circuit from damage. Only remove the pilot control system from the valve if necessary. Tubing and fittings should be kept clean and replaced exactly as removed. Consult appropriate hydraulic schematic to ensure proper re-assembly.
6. Connect solenoid wiring leads to desired switching device, using safe, standard electrical practices.
7. Wire the limit switch contacts to the proper relay connections, using safe, standard electrical practices. Adjust the limit switch collar to the approximate make/break contact position.
8. After installation, vent entrapped air from valve cover and pilot system by following instructions on Technical Bulletin.

Valve Servicing Dimensions

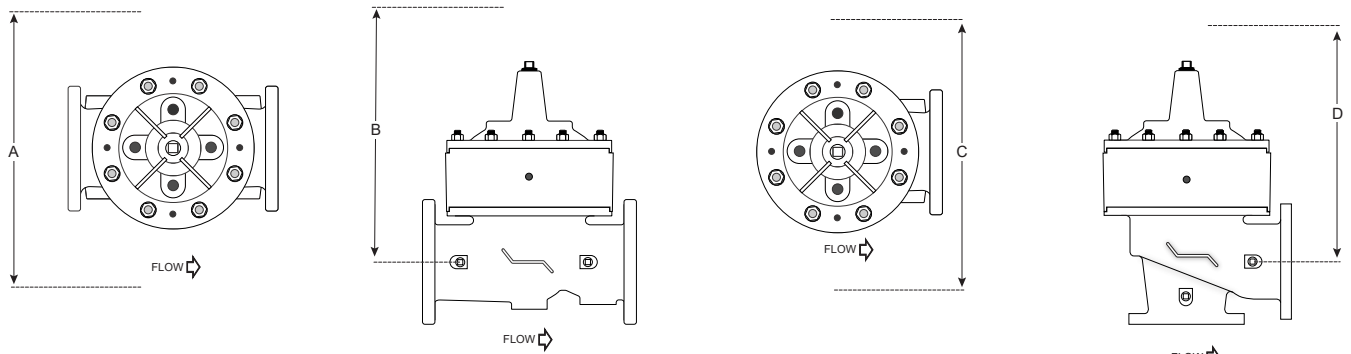

The following tables detail the recommended minimum valve servicing dimensions.

Globe

Size (in)	2	2½	3	4	6	8	10	12	14	16	20	24
A (in)	20	22	22	24	32	34	38	44	48	52	56	56
B (in)	20	22	22	25	36	38	40	44	48	50	50	50

Angle

Size (in)	2	2½	3	4	6	8	10	12	14	16
C (in)	20	22	22	24	32	34	38	44	48	52
D (in)	20	22	22	25	36	38	40	44	48	50

Commissioning the Pump Control Valve

STEP 1

NOTE: System needs to be filled, pressurized, and ready for flow. Due to an internal system check feature, Automatic Control Valve will not flow until pump starts.

Pre-set pilots as noted:

Opening and Closing Speed – Prior to pump start, actuate manual operator on solenoid to enable diaphragm assembly to stroke open and closed. Observing the limit switch stem indicator, monitor rate of opening and closing speed. Adjust accordingly per application requirements.

NOTE: Cycle diaphragm multiple times to confirm rate of movement and remove excess air trapped within the cover chambers (See Figure 1 Below).

To increase the rate of opening/closing, turn the adjustment screws on the speed controls OUT, counterclockwise (See Figure 2B Following Page). To decrease the rate of opening/closing, turn the adjustment screws on the speed controls IN, clockwise (See 2A Following Page).

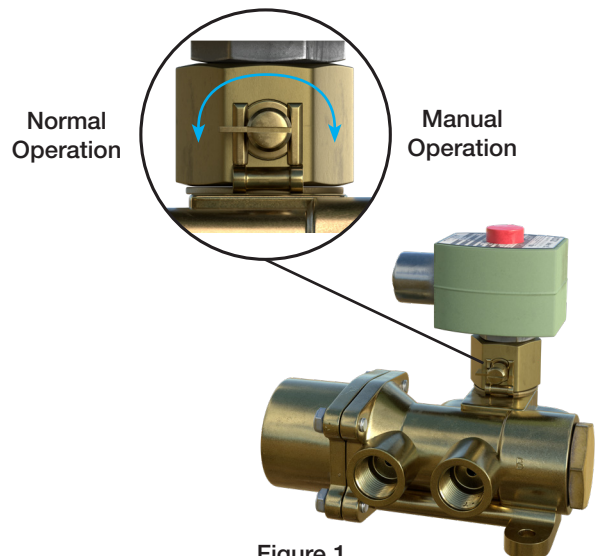

Figure 1
4-Way Solenoid

STEP 2

Prior to pump start, energize the solenoid to confirm connection to power source.

STEP 3

De-energize the solenoid prior to initial pump start.

STEP 4

Energize the solenoid at pump start to open the main valve, checking that the main valve opens.

STEP 5

Opening Speed Needle Valve Adjustment: While free flow goes into the lower chamber, the Opening speed flow control restricts flow out of the upper chamber of the main valve.

If valve opening is too slow, turn the adjustment screw OUT, counterclockwise, increasing the rate of opening.

If valve opening is too quick, turn the adjustment screw IN, clockwise, decreasing the rate of opening.

STEP 6

When pump demand is satisfied, pump will continue to operate as the main valve closes. To close main valve, de-energize the solenoid, checking that the main valve closes.

STEP 7

Closing Speed Flow Adjustment: While free flow goes into the upper chamber, the closing speed flow control restricts flow out of the lower chamber of the main valve.

If valve closing is too slow, turn the adjustment screw OUT, counterclockwise (See Figure 1B), increasing the rate of closing.

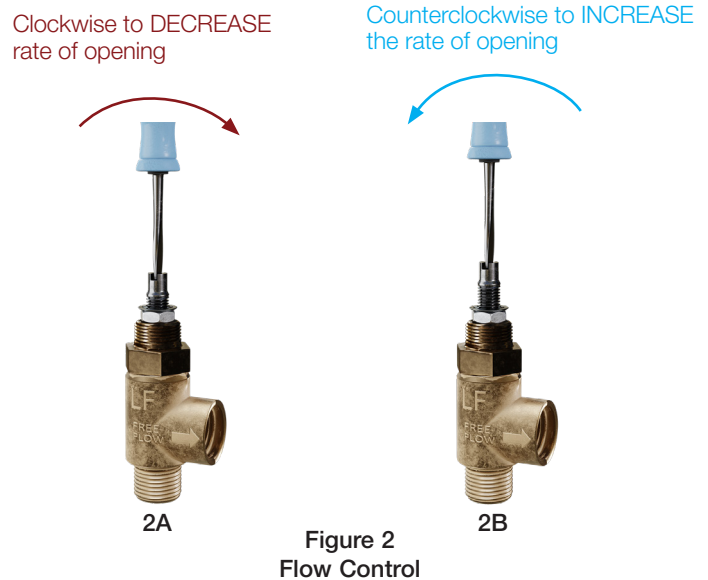

STEP 8

At valve closure booster pump will stop. Adjust limit switch collar to final position to ensure positive actuation of limit switch electrical contact, if necessary, by sliding up/down to location (See Figure 3).

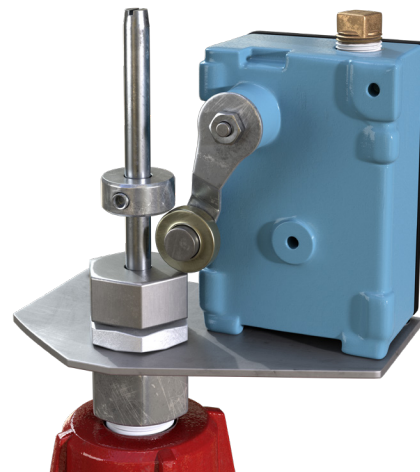

Figure 3
Limit Switch in Closed Position

Automatic Control Valve Maintenance Schedule

To ensure peak performance and longevity of your automatic control valve, Watts/Ames recommends following the below standard maintenance schedule.

- **Monthly Maintenance**
 - Visual inspection of valve(s) for leaks
 - Inspect for proper operation(s); exercise valve.
- **Quarterly Maintenance**
 - Conduct monthly inspection.
 - Validate/Re-establish necessary setpoints of controls/pilots.

- **Annual Maintenance**
 - Conduct monthly & quarterly inspections.
 - Inspect & clean all strainers.
 - Inspect valve coating, touch up as required.
- **3-5 Year Maintenance**
 - Conduct monthly, quarterly, & annual maintenance.
 - Inspect & replace valve elastomers (diaphragm, O-rings, valve/pilot seats)
 - Re-establish necessary set points of controls/pilots.

Troubleshooting Guide

⚠ WARNING

Warning: The valve cannot be serviced under pressure. Upstream and downstream Isolation Valves must be installed to protect system piping. Accurate diagnosis and troubleshooting requires the valve to open fully, and may subject downstream piping and equipment to high pressure and/or flow rates. The downstream Isolation Valve should be kept closed while diagnosing the valve.

Extreme caution should be used while performing the troubleshooting techniques listed below.

Recommended tools for diagnosis: (3) PRESSURE GAUGES, installed to monitor the inlet pressure, outlet pressure, and cover chamber pressure. If included, a POSITION INDICATOR should be installed to visually assess the position of the disc & diaphragm assembly.

Test 1: Diaphragm Seal Test

1. Close upstream & downstream isolation valves. Close pilot isolation valves or remove pilot control tubing to isolate valve cover from incoming fluid & pressure. Remove uppermost cover plug, test cock, or limit switch.
2. With the valve cover chamber vented to atmosphere, partially open the upstream isolation valve, allowing incoming pressure to lift the disc & diaphragm assembly. A volume of water will be displaced from the cover chamber as the valve opens; consult valve specification sheets for approximate cover capacity. A continuous flow of water from the open port indicates a damaged diaphragm or loose disc & diaphragm assembly. Disassemble valve and replace diaphragm or tighten disc & diaphragm assembly.

Test 2: Seat Seal Test

1. Close downstream isolation valve and install pressure gauges on an open inlet and outlet port of main valve.
2. Open upstream isolation valve to allow pressure on to the valve cover. Allow valve to fully close.
3. Monitor downstream pressure gauge; reading should hold steady below incoming pressure. If pressure on downstream side rises to match upstream pressure, leakage is occurring through the seat of the main valve. Disassemble valve, inspect and repair/replace any required parts.
 - a. If gauge pressure rises to match outlet pressure (downstream of closed isolation valve) yet remains below inlet pressure, the isolation valve may be leaking as opposed to main valve seat.

Test 3: Freedom of Movement/Valve Travel Test

1. Close upstream and downstream isolation valves. Install valve position indicator.
2. Partially open upstream isolation valve and allow cover to fill with fluid & pressure, closing the valve fully. Mark the position indicator's full closed position.
3. Isolate cover chamber from receiving fluid and pressure by closing isolation valves or removing control tubing.
4. Carefully vent cover chamber to atmosphere by opening test cock or removing a cover plug. Observe the valve position indicator as the valve travels to the full-open position. The disc & diaphragm assembly should move freely from fully closed to fully open position without binding or "grabbing" at any point during its movement.
 - a. The disc & diaphragm assembly may momentarily "hesitate" while travelling from fully closed to fully open position – this is a normal characteristic of diaphragm operated control valves, and does not indicate mechanical binding or improper valve operation.
 - b. A continuous discharge of water from the cover chamber after venting to atmosphere indicates leakage past the diaphragm.
5. If necessary, disassemble valve and inspect/repair disc & diaphragm assembly.

Troubleshooting Guide

Issue	Possible Cause	Corrective Action	Notes
Main Valve will not open	Closed isolation valves in pilot system.	Check isolation valves, ensure open.	
	Insufficient supply pressure.	Check upstream pressure.	Depending on water source, supply pressure may not be controlled by valve operator.
	Main valve stem assembly corroded/damaged	Inspect stem assembly, clean/replace if necessary.	
	Blockage in pilot system.	Inspect & clean any installed pilot system strainers, check orifice/speed controls for blockages.	
	Improperly configured opening speed control.	Adjust opening speed control to verify functionality, adjust as required.	Standard setting for opening speed control is 1 1/2 - 2 1/2 turns open from full closed position. Can be adjusted in field.
Main Valve will not close	Closed isolation valves in pilot system	Check isolation valves, ensure open.	
	Diaphragm is damaged	Conduct diaphragm seal test, repair and replace if necessary.	
	Main valve stem assembly corroded/damaged.	Inspect stem assembly, clean/replace if necessary.	
	Blockage in main valve.	Perform freedom of movement test; if valve does not close, disassemble and remove blockage.	
	Worn/damaged valve seat.	Perform seat sealing check; disassemble and inspect/repair seat if required.	
	Improperly configured closing speed control.	Adjust closing speed control to verify functionality, adjust as required.	Standard setting for closing speed control is 1 1/2 - 2 1/2 turns open from full closed position. Can be adjusted in field.
Solenoid will not actuate	Possible Cause: Low or no voltage	Check voltage at the solenoid connection, insuring that it has the minimum of 85% of the coils rated voltage.	Should be performed by licensed electrician
	Manual operated is engaged	Turn manual operator counter-clockwise to disengage	

Valve Disassembly Instructions

Before undertaking valve disassembly, it is recommended to gather the following tools to aid you during the process:

- Small & large adjustable wrenches
- Screwdriver set
- Machinist fine metal file
- Fine wire brush
- Bench vise
- Basic valve IO&M manual
- Hammer & dull cold chisel
- Heavy-duty ratchet & socket set
- Hexagonal wrench set
- 320 grit/fine Emery cloth
- Appropriate technical bulletins for valve start-up procedures.

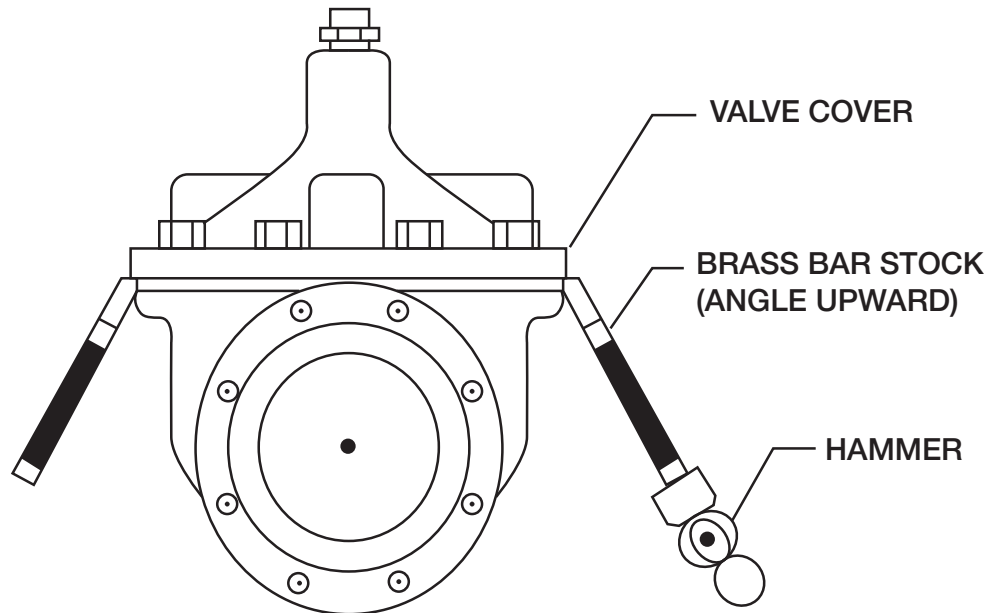

1. Isolate the valve from line pressure and depressurize it to ensure safe working conditions. Disconnect any electrical connections if so equipped.
2. Carefully remove Position Indicator or Limit Switches if equipped. Remove all tubing, fittings, and Control Pilots necessary to easily access and remove the cover. Remove cover nuts and washers.
3. Remove the cover. If cover is not free to be removed, loosen it by tapping upward along its outside edge with a dull cold chisel, pictured above.
 - a. Large valves may require the installation of lifting “eye” bolts in order to facilitate cover removal; installation ports are provided on the cover for this purpose.
4. Remove the Disc and Diaphragm Assembly from the valve body by lifting straight up.
 - a. Large diameter valves may require a lifting “eye” bolt to be installed in the valve stem accessory threads located on the very top of the valve stem.
5. Before removing Stem Nut, examine stem threads for mineral build-up. Remove deposits with a fine wire brush. Extreme care should be taken not to damage the finish on stem guiding surfaces when disassembling. Avoid applying pipe wrenches to top or bottom stem guide surfaces.

6. After removing the Stem Nut, the remainder of the Disc & Diaphragm Assembly should disassemble easily. Polish stem guide surfaces with fine emery cloth to remove any mineral deposits and inspect for excessive wear. Remove any mineral build-up from other components with wire brush or by using a Mineral Dissolving Solution. Inspect parts for wear and replace if necessary.
7. Inspect valve seat. If seat is not damaged, removal is not necessary. If it is damaged please contact factory for instructions.

8. Replace Seat Disc, Diaphragm and Spacer Washers provided in Main Valve repair kit (refer to Table 2 or 3 for correct repair kit part number). Re-assemble in the reverse order of disassembly.

Table 2: Full Port Valve (M100/M1100) Repair Kits

Size (in)	2	2½	3	4	6	8	10	12	14	16
P/N	0677-21	0677-22	0677-23	0677-24	0677-25	0677-26	Consult Factory	0677-28	0677-29	0677-30

Table 3: Reduced Port Valve (M6100 / M61100) Repair Kits

Size (in)	3	4	6	8	10	12	16	20 & 24
P/N	0677-21	0677-23	0677-24	0677-25	0677-26	0677-27	0677-28	0677-30

9. Re-Install Disc and Diaphragm Assembly in the valve, taking care not to damage the lower guide area in the center of the valve seat.
10. Re-install Cover Spring. Replace Valve Cover and tighten Cover Nuts in a crossing pattern to ensure even distribution. Test the Disc and Diaphragm Assembly for smooth travel by following the Freedom of Movement Test procedure in previous section.
11. Test the integrity of the Seat Seal by following the Seat Seal Test procedure in previous section.

ACV Assembly Diagram – Series LFM513-5

NOTICE

Installation: If unit is installed in any orientation other than horizontal (cover up) OR extreme space constraints exist, consult customer service prior to or at the time of order.

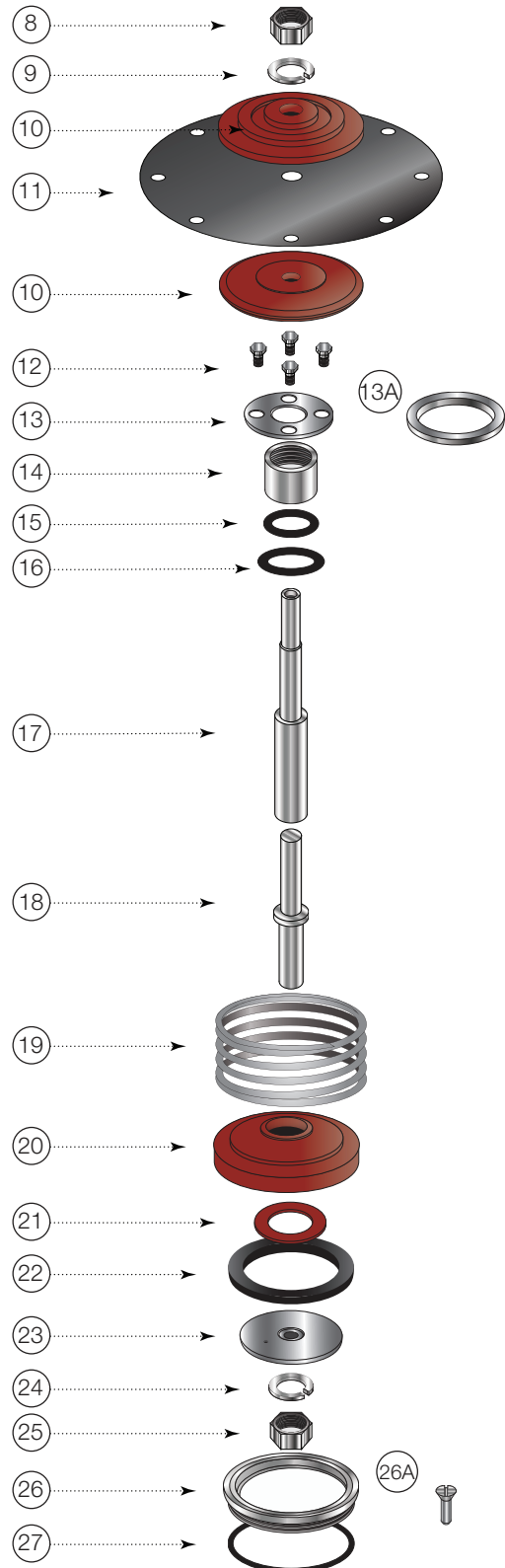
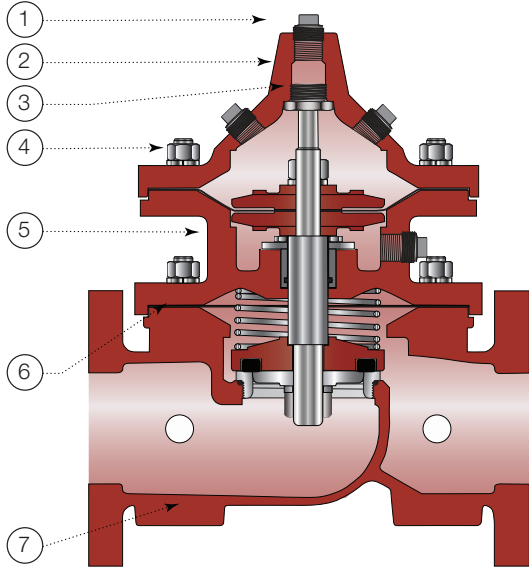

ITEM	DESCRIPTION	MATERIAL
1	Pipe Plug	Lead Free Brass
2	Cover	ASTM A536 65-45-12 Epoxy Coated Ductile Iron
3	Cover Bearing	ASTM A276 304 Stainless Steel
4	Stud with Cover Nut & Washer	ASTM A570 Gr.33 Zinc Plated Steel
5	Upper Body	ASTM A536 65-45-12 Epoxy Coated Ductile Iron
6	Gasket Seal	Buna-N (Nitrile)
7	Body	ASTM A536 65-45-12 Epoxy Coated Ductile Iron
8	Stem Nut	ASTM A276 304 Stainless Steel
9	Lock Washer	ASTM A276 302 Stainless Steel
10	Diaphragm Washer	ASTM A536 65-45-12 Epoxy Coated Ductile Iron
11	Diaphragm*	Buna-N (Nitrile)
12	Inner Bearing Bolts** (3" and Smaller)	ASTM A276 304 Stainless Steel
13	Inner Bearing Retainer** (3" and Smaller)	ASTM A276 302 Stainless Steel
13A	Bearing Retaining Ring** (4" and Larger)	ASTM A276 302 Stainless Steel
14	Inner Bearing	ASTM A276 304 Stainless Steel
15	O-ring*	Buna-N (Nitrile)
16	O-ring*	Buna-N (Nitrile)
17	Upper Stem	ASTM A276 304 Stainless Steel
18	Lower Stem	ASTM A276 304 Stainless Steel
19	Spring	ASTM A276 302 Stainless Steel
20	Disc Retainer	ASTM A536 65-45-12 Epoxy Coated Ductile Iron
21	Spacer Washer*	NY300 Fiber
22	Disc*	Buna-N (Nitrile)
23	Disc Guide	ASTM A743 CF8M (316) Stainless Steel
24	Lock Washer	ASTM A276 304 Stainless Steel
25	Stem Nut	ASTM A276 304 Stainless Steel
26	Seat Ring***	ASTM A743 CF8M (316) Stainless Steel
26A	Seat Screw*** (8" and Larger)	ASTM A276 304 Stainless Steel
27	Seat Gasket *	Buna-N (Nitrile)

* Contained in Main Valve Repair Kit

**4 inch and larger valves do not require Bearing Bolts

***6 inch and smaller valves, Seat Ring is threaded

NOTES

Limited Warranty: Watts Regulator Co. (the "Company") warrants each product to be free from defects in material and workmanship under normal usage for a period of one year from the date of original shipment. In the event of such defects within the warranty period, the Company will, at its option, replace or recondition the product without charge.

THE WARRANTY SET FORTH HEREIN IS GIVEN EXPRESSLY AND IS THE ONLY WARRANTY GIVEN BY THE COMPANY WITH RESPECT TO THE PRODUCT. THE COMPANY MAKES NO OTHER WARRANTIES, EXPRESS OR IMPLIED. THE COMPANY HEREBY SPECIFICALLY DISCLAIMS ALL OTHER WARRANTIES, EXPRESS OR IMPLIED, INCLUDING BUT NOT LIMITED TO THE IMPLIED WARRANTIES OF MERCHANTABILITY AND FITNESS FOR A PARTICULAR PURPOSE.

The remedy described in the first paragraph of this warranty shall constitute the sole and exclusive remedy for breach of warranty, and the Company shall not be responsible for any incidental, special or consequential damages, including without limitation, lost profits or the cost of repairing or replacing other property which is damaged if this product does not work properly, other costs resulting from labor charges, delays, vandalism, negligence, fouling caused by foreign material, damage from adverse water conditions, chemical, or any other circumstances over which the Company has no control. This warranty shall be invalidated by any abuse, misuse, misapplication, improper installation or improper maintenance or alteration of the product.

Some States do not allow limitations on how long an implied warranty lasts, and some States do not allow the exclusion or limitation of incidental or consequential damages. Therefore the above limitations may not apply to you. This Limited Warranty gives you specific legal rights, and you may have other rights that vary from State to State. You should consult applicable state laws to determine your rights. **SO FAR AS IS CONSISTENT WITH APPLICABLE STATE LAW, ANY IMPLIED WARRANTIES THAT MAY NOT BE DISCLAIMED, INCLUDING THE IMPLIED WARRANTIES OF MERCHANTABILITY AND FITNESS FOR A PARTICULAR PURPOSE, ARE LIMITED IN DURATION TO ONE YEAR FROM THE DATE OF ORIGINAL SHIPMENT.**



USA: T: (978) 689-6066 • F: (978) 975-8350 • Watts.com
Canada: T: (888) 208-8927 • F: (905) 481-2316 • Watts.ca
Latin America: T: (52) 55-4122-0138 • Watts.com