

Watts Regulator Examines Product Applications for
The 2000 International Plumbing Code



INTRODUCTION

We are pleased to present to you excerpts from the most recent edition of the International Plumbing Code along with applicable specifications for Watts Regulator products that apply to these sections. Excerpts of the International Plumbing Code 2000 are presented as extracts at the top

of the page along with engineering specifications for Watts Regulator Company products that comply with the corresponding IPC Code requirements at the bottom.

TABLE OF CONTENTS

<p>Chapter 3</p> <p>Section 312 312.9 312.9.1 312.9.2</p> <p>Chapter 4</p> <p>Section 406 406.2</p> <p>Section 408 408.2</p> <p>Section 409 409.2</p> <p>Section 414 414.1</p> <p>Section 422 422.3</p> <p>Section 423 423.1</p> <p>Section 424 424.4</p> <p>Section 425 425.4.1</p> <p>Chapter 5</p> <p>Section 501 501.2 501.6 502.2 502.6</p> <p>Section 504 504.1 504.2 504.4 504.6.1 504.6.2</p> <p>Chapter 6</p> <p>Section 604 604.8 604.9</p> <p>Section 605 605.4.1 605.22.1</p> <p>Section 606 606.1 606.2 606.5.1</p> <p>606.5.9 606.5.10</p> <p>Section 607 607.3</p>	<p>General Regulations</p> <p>Tests and Inspections</p> <p> Inspection of Backflow Prevention Assemblies 4</p> <p> Inspections 4</p> <p> Testing 4</p> <p>Fixtures, Faucets and Fixture Fittings</p> <p>Automatic Clothes Washers</p> <p> Water Connection 5</p> <p>Bidets</p> <p> Water Connection 6-7</p> <p>Dishwashing Machines</p> <p> Water Connection 8</p> <p>Garbage Can Washers</p> <p> Water Connection 8</p> <p>Health Care Fixtures and Equipment</p> <p> Protection 9</p> <p>Specialty Plumbing Fixtures</p> <p> Water Connection 10</p> <p>Faucets and Other Fixture Fittings</p> <p> Shower Valves 11</p> <p>Flushing Devices for Water Closets and Urinals</p> <p> Ball Cocks. 12</p> <p>Water Heaters</p> <p>General</p> <p> Water Heater as Space Heater 13</p> <p> Water Temperature Control in Piping from Tankless Heaters 13</p> <p> Water Heaters Installed in Garages 14</p> <p> Seismic Supports 14</p> <p>Safety Devices</p> <p> Anti-siphon Devices 14</p> <p> Vacuum Relief Valve 14</p> <p> Relief Valve 15</p> <p> Discharge 15</p> <p> Materials 15</p> <p>Water Supply and Distribution</p> <p>Design of Building Water Distribution System</p> <p> Water Pressure Reducing Valve or Regulator 16-17</p> <p> Water Hammer 17</p> <p>Materials, Joints and Connections</p> <p> Dual Check-Valve-Type Backflow Preventer 18</p> <p> Copper or Copper-alloy Tubing to Galvanized Steel Pipe 18</p> <p>Installation of the Building Water Distribution System</p> <p> Location of Full-open Valves 19</p> <p> Location of Shutoff Valves 20</p> <p> Water Pressure Booster Systems Required 21</p> <p> Pressure Tanks, Vacuum Relief. 22</p> <p> Pressure Relief for Tanks 22</p> <p>Hot Water Supply System</p> <p> Thermal Expansion Control 23</p>
--	--

TABLE OF CONTENTS CONT'D

Section	608	Protection of Potable Water Supply	
	608.1	General	24
	608.2	Plumbing Fixtures	24
	608.3	Devices, Appurtenances, Appliances and Apparatus	25
	608.3.1	Special Equipment, Water Supply Protection	26
	608.13	Backflow Protection	27
	608.13.2	Reduced Pressure Principle Backflow Preventers	27-28
	608.13.3	Backflow Preventer with Intermediate Atmospheric Vent	28
	608.13.5	Pressure-type Vacuum Breakers	29
	608.13.6	Atmospheric-type Vacuum Breakers	30
	608.13.7	Double Check Valve Assemblies	31-32
	608.13.8	Spill-proof Vacuum Breakers	33
Section	608.14	Location of Backflow Preventers	
	608.14.1	Outdoor Enclosures for Backflow Preventers	34
Section	608.15	Protection of Potable Water Outlets	
	608.15.2	Protection by a Reduced Pressure Principle Backflow Preventer	35
	608.15.3	Protection by a Backflow Preventer with Intermediate Atmospheric Vent	36
	608.15.4	Protection by a Vacuum Breaker	36
	608.15.4.2	Hose Connections	36-37
Section	608.16	Connections to the Potable Water System	
	608.16.1	Beverage Dispensers	37
	608.16.2	Connections to Boilers	38
	608.16.4	Connections to Automatic Fire Sprinkler Systems and Standpipe Systems.	39-40
	608.16.4.1	Additives or Non-potable Source	41
	608.16.5	Connections to Lawn Irrigation Systems	42-43
	608.16.6	Connections Subject to Back Pressure	44-45
	608.16.7	Chemical Dispensers	46
	608.16.8	Portable Cleaning Equipment	46
	608.16.9	Dental Pump Equipment	46
Chapter 10		Traps, Interceptors and Separators	
Section	1002	Trap Requirements	
	1002.4	Trap Seals	47

NOTE:

All Watts Regulator Company engineering specifications shown on the following pages are for products that comply with the corresponding IPC Code requirements above them. Watts reserves the right to change or modify product design, construction, specifications, or materials without prior notice and without incurring any obligation to make such changes and modifications on Watts products previously or subsequently sold.

IPC International Plumbing Code/2000. Copyright ©2000 by International Code Council, Inc., Falls Church, Virginia. 2000 International Plumbing Code. Reproduced with permission. All rights reserved. Published by arrangements with author. No part may be reproduced or transmitted in any form or by any means, electronic or mechanical, including photocopying, recording or by an information storage or retrieval system without advance permission in writing from the International Code Council, Inc.

IPC 2000 Section 312 Tests and Inspections

312.9 Inspection and testing of backflow prevention assemblies. Inspection and testing shall comply with Sections 312.9.1 and 312.9.2.

312.9.1 Inspections. Annual inspections shall be made of all backflow prevention assemblies and air gaps to determine whether they are operable.

312.9.2 Testing. Reduced pressure principle backflow preventer assemblies, double check-valve assemblies, double detector check valve assemblies and pressure vacuum breaker assemblies shall be tested at the time of installation, immediately after repairs or relocation and at least annually. The testing procedure shall be performed in accordance with one of the following standards:

ASSE 5010-1013-1, Sections I and 2

ASSE 5010-1015-2

ASSE 5010-1015-4, Sections I and 2

ASSE 5010-1047-1, Sections 1, 2, 3 and 4

ASSE 5010-1048-2

ASSE 5010-1048-4, Sections 1, 2, 3 and 4

ASSE 5010-1015-1, Sections I and 2

ASSE 5010-1015-3, Sections I and 2

ASSE 5010-1020-1, Sections I and 2

ASSE 5010-1048- 1, Sections 1, 2, 3 and 4

ASSE 5010-1048-3, Sections 1, 2, 3 and 4

CAN/CSA B64. 10

Applicable Watts Products for IPC Code Section 312.9:

WATTS MODEL TK-DL

Test Kit with Digital Print Out

Specifications:

Backflow preventer test kit shall be of solid state construction with digital display, thermal tape printout, downloading capability, 16 key input keyboard, and 32K of battery backed up memory. Test kit shall come

complete with carrying case, carrying strap, AC charger, a kit of brass adapters, three 6 foot color coded hoses, instructions, warranty, and operation manual. Test kit shall be a Watts Regulator Company model TK-DL.



Watts TK-DL

IPC 2000 Section 406 Automatic Clothes Washers

406.2 Water connection. The water supply to an automatic clothes washer shall be protected against backflow by an air gap installed integrally within the machine conforming to ASSE 1007 or with the installation of a backflow preventer in accordance with Section 608.

Applicable Watts Products for IPC Code Section 406.2:

WATTS SERIES 909QT- HW

Reduced Pressure Zone Backflow Preventer ($3/4''$ - $2''$)

Specifications:

A reduced pressure zone backflow preventer shall be installed at each cross connection to prevent backsiphonage and back-pressure backflow of hazardous materials into the potable water supply. The assembly shall consist of a pressure differential relief valve located in a zone between two positive seating check valves. Backsiphonage protection shall include provision to admit air directly into the reduced pressure zone via a separate channel from the water discharge channel, or directly into the supply pipe via a separate vent. The assembly shall include two resilient seated shutoff valves before and after the assembly, test cocks and a protective strainer upstream of the No. 1 shutoff valve. The assembly (specify Model 909 for temperatures up to 140°F (60°C) or Model 909HW for temperatures up to 210°F (99°C)) shall meet the requirements of ASSE Standard. 1013; AWWA Standard. C-511-92 CSA B64.4; FCCCHR of USC Manual Section 10. The valve shall be a Watts Regulator Company Series 909QTHW.

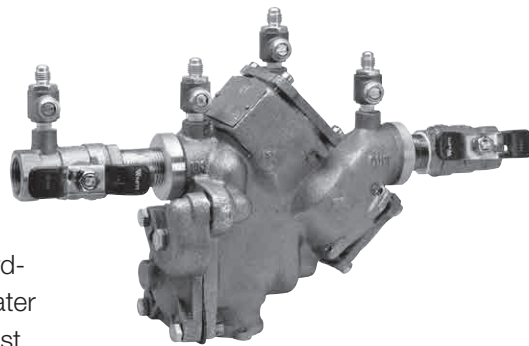

Watts Series 909

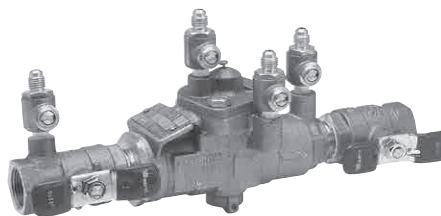

Watts Series 009

Applicable Watts Products for IPC Code Section 406.2:

WATTS SERIES 009

Reduced Pressure Zone Backflow Preventer ($1/4''$ - $3''$)

Specifications:

A reduced pressure zone backflow preventer shall be installed at each potential health hazard location to prevent backflow due to backsiphonage and/or backpressure. The assembly shall consist of an internal pressure differential relief valve located in a zone between two positive seating check modules with captured springs and silicone seat discs. Seats and seat discs shall be replaceable in both check modules and the relief valve. There shall be no threads or screws in the waterway exposed to line fluids. Service of all internal components shall be through a single access cover secured with stainless steel bolts. The assembly shall also include two resilient seated isolation valves, four resilient seated test cocks and an air gap drain fitting. The assembly shall meet the requirements of: USC Manual 8th Edition; ASSE Standard. 1013; AWWA Standard. C511; CSA B64.4. The valve shall be a Watts Regulator Company Series 009.

IPC 2000 Section 408 Bidets

408.2 Water connection. The water supply to a bidet shall be protected against backflow by an air gap or backflow preventer in accordance with Section 608.13.1, 608.13.2, 608.13.3, 608.13.5, 608.13.6 or 608.13.8.

Applicable Watts Products for IPC Code Section 408.2:

WATTS SERIES 009

Reduced Pressure Zone Backflow Preventer (1/4" - 3")

Specifications:

A reduced pressure zone backflow preventer shall be installed at each potential health hazard location to prevent backflow due to backsiphonage and/or backpressure. The assembly shall consist of an internal pressure differential relief valve located in a zone between two positive seating check modules with captured springs and silicone seat discs. Seats and seat discs shall be replaceable in both check modules and the relief valve. There shall be no threads or screws in the waterway exposed to line fluids. Service of all internal components shall be through a single access cover secured with stainless steel bolts. The assembly shall also include two resilient seated isolation valves, four resilient seated test cocks and an air gap drain fitting. The assembly shall meet the requirements of: USC Manual 8th Edition; ASSE Standard. 1013; AWWA Standard. C511; CSA B64.4. The valve shall be a Watts Regulator Company Series 009.

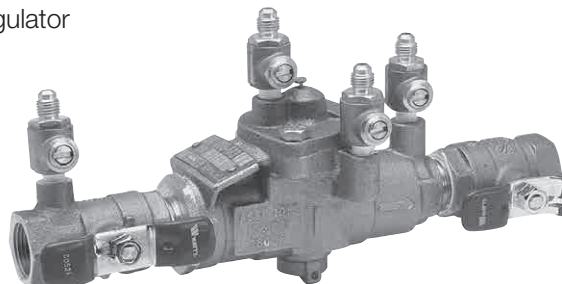

Watts Series 009

WATTS SERIES 909

Reduced Pressure Zone Backflow Preventer (3/4" - 2")

Specifications:

A reduced pressure zone backflow preventer shall be installed at each cross connection to prevent backsiphonage and back-pressure backflow of hazardous materials into the potable water supply. The assembly shall consist of a pressure differential relief valve located in a zone between two positive seating check valves. Backsiphonage protection shall include provision to admit air directly into the reduced pressure zone via a separate channel from the water discharge channel, or directly into the supply pipe via a separate vent. The assembly shall include two resilient seated shutoff valves before and after the assembly, test cocks and a protective strainer upstream of the

No. 1 shutoff valve. The assembly (specify Model 909 for temperatures up to 140°F (60°C) or Model 909HW for temperatures up to 210°F (99°C)) shall meet the requirements of ASSE Standard. 1013; AWWA Standard. C-511-92 CSA B64.4; FCCCHR of USC Manual Section 10. The valve shall be a Watts Regulator Company Series 909QT or 909QTHW.

WATTS SERIES 9D

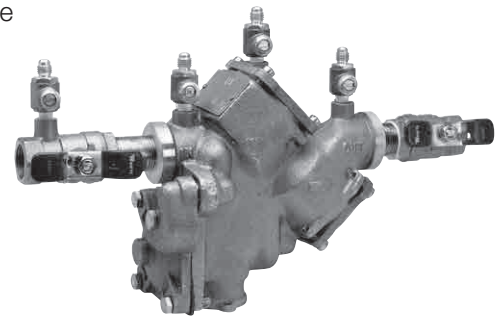

Watts Series 909

IPC 2000 Section 408 Bidets

408.2 Water connection - cont'd

Applicable Watts Products for IPC Code Section 408.2

Backflow Preventer with Intermediate Atmospheric Vent (1/2" - 3/4")

Specifications:

Important: Inquire with governing authorities for local installation requirements. A Dual Check with Atmospheric Vent shall be installed at referenced cross-connections. Valve shall feature stainless steel and rubber internals protected by an integral strainer. Primary check shall be rubber to rubber seated, backed by the secondary check with rubber to metal seating. The device shall be ASSE approved under Standard. 1012 and shall be a Watts Regulator Company Series 9D.



Watts Series 9D

WATTS SERIES 288A

Hot or Cold Water Anti-Siphon Vacuum Breaker (1/4" - 3")

Specifications:

An atmospheric-type anti-siphon vacuum breaker shall be installed where indicated on the plans to prevent the back-siphonage of contaminated water. This device is not to be used under continuous pressure or where there is a possibility that a back-pressure condition may develop. The device shall meet the requirements of ASSE Standard 1001, ANSI A112.1.1 and CSA B64, and shall be a Watts Regulator Company Series 288A.

WATTS SERIES 008PCQT

Health Hazard Vacuum Breaker, Anti-Siphon, Spill Resistant (3/8" - 1")

Specifications:

A spill-resistant vacuum breaker (SVB) shall be installed, in accordance with the manufacturer's instructions, as noted on the plans. The valve shall consist of a one-piece modular check and float assembly made of engineered thermoplastic and housed in a bronze body. Springs shall be stainless steel. The valve shall be constructed with a molded diaphragm separating the air inlet from the potable water supply to prevent spillage. The valve shall be a Watts Regulator Company Series 008PCQT.



Watts Series 008PCQT



Watts Series 288A

WATTS SERIES 800M4QT

Anti-Siphon Pressure Vacuum Breaker (1/2" - 2")

Specifications:

A pressure anti-siphon vacuum breaker shall be installed where indicated on the plans to prevent the backsiphonage of contaminated water. This assembly is not to be used where there is a possibility that a back pressure condition may develop. The assembly will incorporate an acetal bonnet with silicone rubber O-ring seal and silicone rubber seat disc. The valve shall have replaceable seats. Check assembly shall be guided over its full stroke by 'V' notch guides. The assembly shall meet the requirements of ANSI/ASSE Standard 1020. The valve shall be a Watts Regulator Company Series 800M4QT.



Watts Series 800M4QT

IPC 2000 Section 409 Dishwashing Machines

409.2 Water connection. The water supply to a dishwashing machine shall be protected against backflow by an air gap or backflow preventer in accordance with Section 608.

Engineering Note:

Due to piping variations there is a possibility of protecting the potable water supply with an atmospheric vacuum breaker, a pressure type vacuum breaker or a reduced pressure type backflow preventer. Situations favoring either of the first two methods are very limited. It is

therefore suggested that a reduced pressure principle backflow preventer, such as the Watts 909, be specified. This will insure the protection of the potable water supply under all circumstances. Please refer to page 6 of this document for applicable product specifications.

IPC 2000 Section 414 Garbage Can Washers

414.1 Water connection. The water supply to a garbage can washer shall be protected against backflow by an air gap or a backflow preventer in accordance with Section 608.13.1, 608.13.2, 608.13.3, 608.13.5, 608.13.6 or 608.13.8.

Engineering Note:

Due to piping variations there is a possibility of protecting the potable water supply with an atmospheric vacuum breaker, a pressure type vacuum breaker or a reduced pressure type backflow preventer. Situations favoring either of the first two methods are very limited. It is

therefore suggested that a reduced pressure principle backflow preventer, such as the Watts 909, be specified. This will insure the protection of the potable water supply under all circumstances. Please refer to page 6 of this document for applicable product specifications.

IPC 2000 Section 422 Health Care Fixtures and Equipment

422.3 Protection. All devices, appurtenances, appliances and apparatus intended to serve some special function, such as sterilization, distillation, processing, cooling, or storage of ice or foods, and that connect to either the water supply or drainage system, shall be provided with protection against backflow, flooding, fouling, contamination of the water supply system and stoppage of the drain.

Applicable Watts Products for IPC Code Section 422.3:

WATTS SERIES 009

Reduced Pressure Zone Backflow Preventer (1/4" - 3")

Specifications:

A reduced pressure zone backflow preventer shall be installed at each potential health hazard location to prevent backflow due to backsiphonage and/or backpressure. The assembly shall consist of an internal pressure differential relief valve located in a zone between two positive seating check modules with captured springs and silicone seat discs. Seats and seat discs shall be replaceable in both check modules and the relief valve. There shall be no threads or screws in the waterway exposed to line fluids. Service of all internal components shall be through a single access cover secured with stainless steel bolts. The assembly shall also include two resilient seated isolation valves, four resilient seated test cocks and an air gap drain fitting. The assembly shall meet the requirements of: USC Manual 8th Edition; ASSE Standard. 1013; AWWA Standard. C511; CSA B64.4. The valve shall be a Watts Regulator Company Series 009.

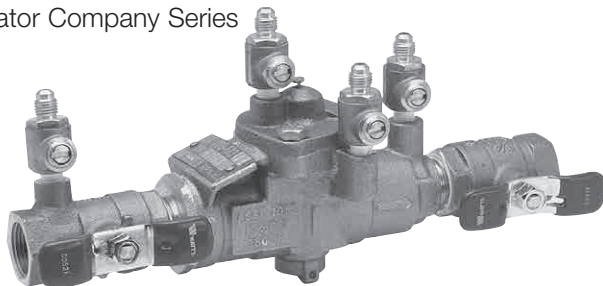

Watts Series 009

WATTS SERIES 288A

Hot or cold Water Anti-Siphon Vacuum Breaker (1/4" - 3")

Specifications:

An atmospheric-type anti-siphon vacuum breaker shall be installed where indicated on the plans to prevent the backsiphonage of contaminated water. This device is not to be used under continuous pressure or where there is a possibility that a back pressure condition may develop. The device shall meet the requirements of ASSE Standard 1001, ANSI A112.1.1 and CSA B64, and shall be a Watts Regulator Company Series 288A.



Watts Series 288A

WATTS SERIES 008PCQT

Health Hazard Vacuum Breaker, Anti-Siphon, Spill Resistant (3/8" - 1")

Specifications:

A spill-resistant vacuum breaker (SVB) shall be installed, in accordance with the manufacturer's instructions, as noted on the plans. The valve shall consist of a one-piece modular check and float assembly made of engineered thermoplastic and housed in a bronze body. Springs shall be stainless steel. The valve shall be constructed with a molded diaphragm separating the air inlet from the potable water supply to prevent spillage. The valve shall be a Watts Regulator Company Series 008PCQT.



Watts Series 008PCQT

IPC 2000 Section 423 Specialty Plumbing Fixtures

423.1 Water connections. Baptisteries, ornamental and lily pools, aquariums, ornamental fountain basins, swimming pools, and similar constructions, where provided with water supplies, shall be protected against backflow in accordance with Section 608.

Applicable Watts Products for IPC Code Section 423.1:

WATTS SERIES 009

Reduced Pressure Zone Backflow Preventer (1/4" - 3")

Specifications:

A reduced pressure zone backflow preventer shall be installed at each potential health hazard location to prevent backflow due to backsiphonage and/or backpressure. The assembly shall consist of an internal pressure differential relief valve located in a zone between two positive seating check modules with captured springs and silicone seat discs. Seats and seat discs shall be replaceable in both check modules and the relief valve. There shall be no threads or screws in the waterway exposed to line fluids. Service of all internal components shall be through a single access cover secured with stainless steel bolts. The assembly shall also include two resilient seated isolation valves, four resilient seated test cocks and an air gap drain fitting. The assembly shall meet the requirements of: USC Manual 8th Edition; ASSE Standard. 1013; AWWA Standard. C511; CSA B64.4. The valve shall be a Watts Regulator Company Series 009.

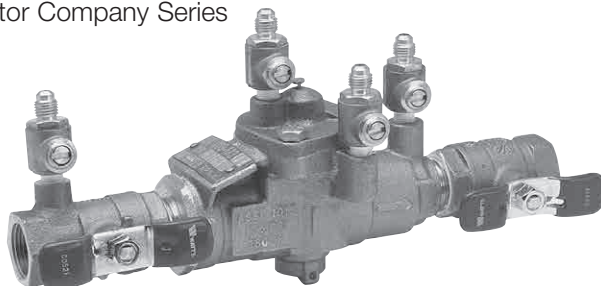

Watts Series 009

WATTS SERIES 288A

Hot or cold Water Anti-Siphon Vacuum Breaker (1/4" - 3")

Specifications:

An atmospheric-type anti-siphon vacuum breaker shall be installed where indicated on the plans to prevent the backsiphonage of contaminated water. This device is not to be used under continuous pressure or where there is a possibility that a back pressure condition may develop. The device shall meet the requirements of ASSE Standard 1001, ANSI A112.1.1 and CSA B64, and shall be a Watts Regulator Company Series 288A.



Watts Series 288A

WATTS SERIES 008PCQT

Health Hazard Vacuum Breaker, Anti-Siphon, Spill Resistant (3/8" - 1")

Specifications:

A spill-resistant vacuum breaker (SVB) shall be installed, in accordance with the manufacturer's instructions, as noted on the plans. The valve shall consist of a one-piece modular check and float assembly made of engineered thermoplastic and housed in a bronze body. Springs shall be stainless steel. The valve shall be constructed with a molded diaphragm separating the air inlet from the potable water supply to prevent spillage. The valve shall be a Watts Regulator Company Series 008PCQT.



Watts Series 008PCQT

IPC 2000 Section 424 Faucets and Other Fixture Fittings

424.4 Shower valves. Shower and tub-shower combination valves shall be balanced pressure, thermostatic or combination balanced-pressure/thermostatic valves that conform to the requirements of ASSE 1016 or CSA CAN/CSA-B125. Valves shall be equipped with a means to limit the maximum setting of the valve to 120°F (49°C), which shall be field adjusted in accordance with the manufacturer's instructions. Multiple (gang) showers supplied with a single tempered water supply pipe shall have the water supply for such showers controlled by an approved master thermostatic mixing valve.

Applicable Watts Products for IPC Code Section 424.4:

WATTS SERIES L111

Thermostatic Mixing Valve (1/2")

Specifications:

A thermostatic mixing valve shall be installed on the hot water supply to fixture. The valve shall be ASSE standard 1016 approved and control the temperature of the hot water to the fixture. The valve shall have 1/2 inch (15mm) female NPT inlet and outlet connections. It shall have a brass body. The valve shall have integral mounting holes to enable the valve to be secured to a wall or suitable enclosure. The valve shall include a tamper resistant thermo-plastic enclosure to protect against unauthorized adjustment of the outlet temperature or removal of mounting fasteners. The valve shall be of a single replaceable cartridge design to allow service or repair of the valve without removal of the valve from the system piping or disassembly of internal valve components. The Thermostatic Mixing Valve(s) shall be a Watts Regulator Company Series L111.



Watts Series L111

WATTS SERIES MMV

Thermostatic Mixing Valve (1/2" - 1")

Specifications:

A Watts MMV thermostatic mixing valve shall be installed on the hot water supply to fixture. The valve shall be ASSE standard 1016 listed and control the temperature of the hot water. It shall have a bronze or brass body and shall include integral check valves and an adjustment cap with locking feature. The valve shall be provided with solder (-US) or threaded (-UT) union connections. The valve shall be a Watts Regulator Company Series MMV.



Watts Series MMV

IPC 2000 Section 425 Flushing Devices for Water Closets and Urinals

425.4.1 Ball cocks. All flush tanks shall be equipped with an anti-siphon ball cock conforming to ASSE 1002 or CSA B 125. The ball cock backflow preventer shall be located at least 1 inch (25 mm) above the full opening of the overflow pipe.

WATTS SERIES GOVERNOR 80

Ball Cock and Thermal Expansion Relief Valve (10", 11 1/2", 12 1/2")

Specifications:

The valve shall be tested and certified under ASSE Standard 1002 and meet IAPMO, and CSA requirements for anti-siphon ball cocks. All materials in contact with water shall be FDA approved under DVR-21-177-2600. The thermal expansion relief valve shall be standardly set at 80psi to meet existing codes and shall be non-adjustable. The valve shall be a Watts Regulator Company Series Governor 80.

Applicable Watts Products for IPC Code Section 425.4.1:



Watts Series Governor 80®

IPC 2000 CODE - CHAPTER 5 - WATER HEATERS

IPC 2000 Section 501 General

501.2 Water heater as space heater. Where a combination potable water heating and space heating system requires water for space heating at temperatures higher than 140°F (60°C), a tempering valve shall be provided to limit the water supplied to the potable hot water distribution system to a temperature of 140°F (60°C). The potability of the water shall be maintained throughout the system.

501.6 Water temperature control in piping from tankless heaters. The temperature of water from tankless water heaters shall be a maximum of 140°F (60°C) when intended for domestic uses. This provision shall not supersede the requirement for protective shower valves in accordance with Section 424.4.

WATTS SERIES 1170/ L1170

Thermostatic Mixing Valve (1/2" - 1")

Specifications:

The valve shall be installed on water heating equipment to provide tempered water to supply piping. Valve shall have a bronze/brass body, include integral check valves and operate so that the thermostat controls the cold and hot water ports. The valve shall be provided with solder (-US) or threaded (-UT) connections. Valve shall be ASSE Standard 1017 Listed. The valve shall be a Watts Regulator Company Series 1170/L1170.

Applicable Watts Products for IPC Code Section 501.2 and 501.6:



Watts Series 1170/L1170

IPC 2000 CODE - CHAPTER 5 - WATER HEATERS

IPC 2000 Section 502 General - cont'd

502.2 Water heaters installed in garages. Water heaters having an ignition source shall be elevated such that the source of ignition is not less than 18 inches (457 mm) above the garage floor.

502.6 Seismic supports. Where earthquake loads are applicable in accordance with the International Building Code, water heater supports shall be designed and installed for the seismic forces in accordance with the International Building Code.

Applicable Watts Products for IPC Code Section 502.2:

WATTS MODELS AS-20, AS-22, AS-26, AS-30, DPS-20 AND ENS-20

Water Heater Stands

Specifications:

Watts/Spacemaker water heater stands, models AS-20, AS-22, AS-26, AS-30, or drip pan stand, DPS-20 or Enclosed Stand, Model ENS-20 shall be used in garages to raise water heater flame element 18" above the floor. Construction shall be of galvanized steel for safety and strength and to resist rotting, melting or burning. All models use floating seismic clips to secure stand to wall studs.



Watts DPS-20

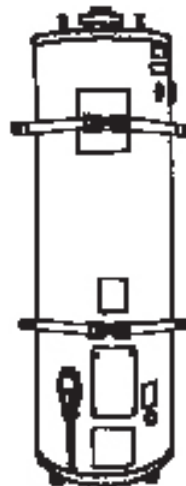

Watts TSE-75

Applicable Watts Products for IPC Code Section 502.6:

WATTS MODELS E-50, E-100, E-75, E-120, TSE-75 AND TSE-75P

Water Heater Restraints

Specifications:

Watts/Spacemaker water heater restraints, models E-50, E-100, E-75, E-120, TSE-75 or TSE-75P shall be used to strap the water heater securely to the wall using lag bolts. Construction shall be of galvanized steel for safety and strength.

IPC 2000 Section 504 Safety Devices

504.1 Anti-siphon devices. An approved means, such as a cold water "dip" tube with a hole at the top or a vacuum relief valve installed in the cold water supply line above the top of the heater or tank shall be provided to prevent siphoning of any storage water heater or tank.

504.2 Vacuum relief valve. Bottom fed water heaters and bottom fed tanks connected to water heaters shall have a vacuum relief valve installed. The vacuum relief valve shall comply with ANSI Z21.22.

WATTS SERIES N36

Vacuum Relief Valve (1/2", 3/4")

Specifications:

The valve shall be installed on domestic hot water supply tanks/heaters/unit heaters/ steam kettles as indicated on plans. The vacuum relief valve shall be ANSI Z21.22 rated

Applicable Watts Products for IPC Code Section 504.2:

and CSA certified. The vacuum relief valve shall have an all brass body and include a protective cap. The valve shall be a Watts Regulator Company Series N36.



Watts Series N36

IPC 2000 Section 504 Safety Devices - cont'd

504.4 Relief valve. All storage water heaters operating above atmospheric pressure shall be provided with an approved, self closing (levered) pressure relief valve and temperature relief valve or combination thereof. The relief valve shall conform to ANSI Z21.22. The relief valve shall not be used as a means of controlling thermal expansion.

504.6.1 Discharge. The relief valve shall discharge full size to a safe place of disposal such as the floor, outside the building, or an indirect waste receptor. The discharge pipe shall not have any trapped sections and shall have a visible air gap or air gap fitting located in the same room as the water heater. The discharge shall be installed in a manner that does not cause personal injury to occupants in the immediate area or structural damage to the building.

504.6.2 Materials. Relief valve discharge piping shall be of those materials listed in Section 605.5 or shall be tested, rated and approved for such use in accordance with ASME 112.4. 1. Piping from safety pan drains shall be of those materials listed in Table 605.5.

Applicable Watts Products for IPC Code Section 504.4:

WATTS SERIES 100XL Temperature and Pressure Relief Valves (3/4")

Specifications:

Each hot water storage heater shall be equipped with an CSA and A.S.M.E. rated automatic temperature and pressure relief valve to protect the heater from excessive pressure and temperature. The device shall be ANSI Z21.22 certified. The BTU discharge capacity of the device shall be in excess of the BTU input rating of the heater. The valve shall be a Watts Regulator Company Series 100XL.



Watts Series 100XL

WATTS SERIES 40, 140, 240 & 340 Commercial Capacity T&P Relief Valves (3/4" - 2")

Specifications:

Each hot water storage heater shall be equipped with an automatic temperature and pressure relief valve to protect the heater from excessive pressure and excessive temperature. The device shall be certified as meeting the requirements of ASME low pressure heating boiler code and ANSI Z21.22. The BTU discharge capacity of the device shall be in excess of the BTU input rating of the heater. The valve shall be a Watts Regulator Company Series 40, 140, 240 and 340.



Watts Series 40

Applicable Watts Products for IPC Code Section 504.6.1:

WATTS MODELS 100DT & 100DT-A Temperature and Pressure Relief Valve Drain Lines

Specifications:

Residential water heaters having relief valves with 3/4" outlets shall be equipped with a relief valve drain line. Drain line shall be constructed to conform with AGA ER48-22 and shall meet the requirements of the Department of Housing and Urban Development. The drain line shall be constructed so as to be able to withstand inlet steam pressure of 15psi or 250°F. Provisions shall be made so that discharge from the drain line will not cause personal injury or property damage. Temperature and pressure drain line shall be a Watts Regulator Company model 100DT or 100DT-A.



Watts Models 100DT and 100DT-A

IPC 2000 Section 604 Design of Building Water Distribution System

604.8 Water-pressure reducing valve or regulator. Where water pressure within a building exceeds 80 psi (552 kPa) static, an approved water-pressure reducing valve conforming to ASSE 1003 with strainer shall be installed to reduce the pressure in the building water distribution piping to 80psi (552 kPa) static or less.

Applicable Watts Products for IPC Code Section 604.8:

WATTS SERIES 223S

Super Capacity Water Pressure Regulators (1/2" - 3")

Specifications:

A pressure regulating valve shall be installed where noted to reduce supply pressures to 50psi or less. The installation shall include a strainer on the inlet side of the regulator. The regulator shall feature a removable seat disc and disc holder that can be removed in-line without special tools. The valve diaphragm shall resist hot or cold water temperature damage. The spring cage shall be sealed for below grade service. Adjusting screw and cage screws shall be corrosion resistant. Approved valves shall comply with ASSE 1003. The valve shall be a Watts Regulator Company Series 223S.

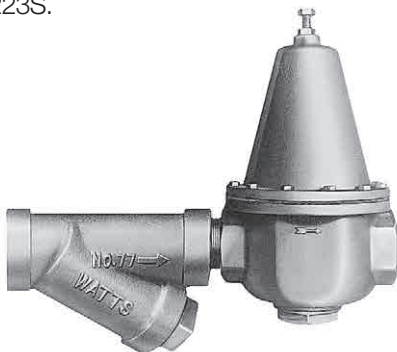

Watts Series 223

WATTS SERIES 25AUB

Water Pressure Reducing Valves (1/2" - 2")

Specifications:

When the supply main pressure exceeds 60psi (413 kPa), an approved water pressure reducing valve and strainer shall be installed on the water service pipe near its entrance to the building to reduce the water pressure to 50psi (345 kPa) or lower. Sill cocks and outside wall hydrants may be left on full main pressure at the option of the owner. For service water systems up to and including 2" (50mm) provision shall be made to permit the bypass flow of water around the valve back into the supply main when pressures, due to thermal expansion on the outlet side of the valve, exceed the pressure in the supply main. Pressure reducing valves with built-in bypass check valves will be acceptable. Approved valves shall comply with ASSE 1003. The valve shall be a Watts Regulator Company Series 25AUB.

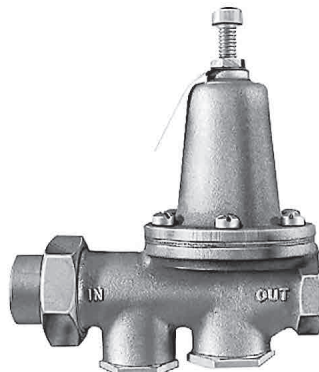

Watts Series 25AUB

WATTS SERIES U5B

Water Pressure Reducing Valves (1/2" - 2")

Specifications:

When supply main pressure exceeds 60psi (413 kPa), an approved water pressure reducing valve and strainer shall be installed on the water service pipe near its entrance to the building to reduce the water pressure to 50psi (345 kPa) or lower. Sill cocks and outside wall hydrants may be left on full main pressure at the option of the owner. For service water systems up to and including 2" (50mm), provision shall be made to permit the bypass flow of water around the valve back into the main when pressures, due to thermal expansion on the outlet side of the valve, exceed the pressure in the main. Pressure reducing valves with built-in bypass check valves will be acceptable. Approved valves shall comply fully with ASSE Standard No. 1003. The valve shall be a Watts Regulator Company Series U5B.



Watts Series U5B

continued on following page

IPC 2000 Section 604 Design of Building Water Distribution System

604.8 Water-pressure reducing valve or regulator - cont'd.

WATTS SERIES 115

Water Pressure Reducing Valves (1¹/₄" - 24")

Specifications:

Watts Series 115/1115 automatically reduces a higher inlet pressure to a constant lower pressure regardless of changing flow rates and/or varying inlet pressures.

Body shall be ductile iron ANSI B16.1 fusion bond epoxy coated, inside and out. Diaphragm actuated by hydraulic pilot. Valves shall be appropriate for dead end service. All elastomers shall be of FDA approved materials. Seat shall be renewable

Applicable Watts Products for IPC Code Section 604.8 - cont'd

316 stainless steel. The disc shall be quad seal retained on three sides by the disc holder. Disc holder shall be configured to create a needle valve for smooth laminar flow over the seat when low flows are required. Disc/diaphragm assembly must be top and bottom guided to assure proper disc/seat alignment. Raised sharp seats will not be accepted. Consult your local Watts agent for sizing and application help.

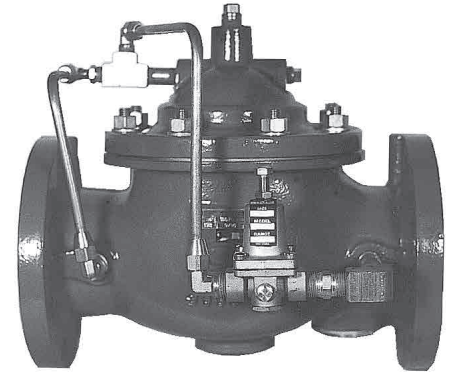

Watts Series 115

IPC 2000 Section 604 Design of Building Water Distribution System - cont'd

604.9 Water hammer. The flow velocity of the water distribution system shall be controlled to reduce the possibility of water hammer. A water-hammer arrestor shall be installed where quick-closing valves are utilized, unless otherwise approved. Water-hammer arrestors shall be installed in accordance with the manufacturer's specifications. Water-hammer arrestors shall conform to ASSE 1010.

WATTS SERIES 15

Water Hammer Arrestors (1/2" - 2")

Specifications:

Water hammer arrestors shall be Watts Regulator Company Series 15. They must be ASSE Standard 1010 approved, ANSI A112.26.1M approved, P.D.I. WH201 approved and certified.

Construction shall be:

Bodies - Hard drawn copper with custom internal mirror finish.

Piston - Threaded adapter and cap machined of free cutting brass.

Applicable Watts Products for IPC Code Section 604.9:

Seals - O-Rings made of EPDM

Seal Lubricant - Dow-Corning silicone compound #111, FDA approved.

Operating Pressure - 150psi

Temperature Range - 33°F - 180°F

Valves must be able to operate properly in any position and be factory pre-charged, permanently capped and epoxy sealed.



Watts Series 15

IPC 2000 Section 605 Materials, Joints and Connections

605.4.1 Dual check-valve-type backflow preventer. Where a dual check valve backflow preventer is installed on the water supply system, it shall comply with ASSE 1024.

WATTS SERIES 7

Dual Check Backflow Preventer (1/2" - 1 1/4")

Specifications:

The dual check backflow preventer shall meet the domestic requirements of ANSI/ASSE Standard 1024, and bear the seal of approval. It shall be bronze-bodied and include not less than one union, with the union nut drilled to accept a tamper-proofing

Applicable Watts Products for IPC Code Section 605.4.1:

lock wire. A brass identification tag indicating direction of flow shall be securely attached to the valve body by corrosion-resistant mechanical fasteners. The dual check shall be Watts Regulator Company Series 7.

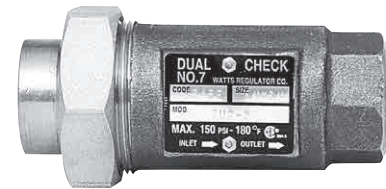

Watts Series 7

IPC 2000 Section 605 Materials, Joints and Connections

605.22.1 Copper or copper-alloy tubing to galvanized steel pipe. Joints between copper or copper-alloy tubing and galvanized steel pipe shall be made with a brass converter fitting or dielectric fitting. The copper tubing shall be soldered to the fitting in an approved manner, and the fitting shall be screwed to the threaded pipe.

WATTS SERIES 3000

Dielectric Pipe Fittings/Unions

Specifications:

All piping of dissimilar metals shall be joined with a dielectric union. All threaded unions must be rated minimum 210°F @ 250psi (Gasket GA) water, air, oil, natural gas, propane, gasoline, kerosene, mineral oil, and alkalines. Gasket (GB) Steam 200°F, 50psi. Flanged fittings 300°F, 175psi. Meet the requirements of

Applicable Watts Products for IPC Code Section 605.22.1:

ANSI B16.39. Must withstand a minimum of 600 volts on a dry line with no flash over. All connections must be verified for temperature, pressure and media requirements. "Dielectric Nipples" shall be unacceptable. The fittings shall be Watts Regulator Company Series 3000.



Watts Series 3000

IPC 2000 Section 606 Installation of the Building Water Distribution System

606.1 Location of full-open valves. Full-open valves shall be installed in the following locations:

1. On the building water service pipe from the public water supply near the curb.
2. On the water distribution supply pipe at the entrance into the structure.
3. On the discharge side of every water meter.
4. On the base of every water riser pipe in occupancies other than multiple family residential occupancies that are two stories or less in height and in one- and two-family residential occupancies.
5. On the top of every water down-feed pipe in occupancies other than one- and two-family residential occupancies.
6. On the entrance to every water supply pipe to a dwelling unit, except where supplying a single fixture equipped with individual stops.
7. On the water supply pipe to a gravity or pressurized water tank.
8. On the water supply pipe to every water heater.

Applicable Watts Products for IPC Code Section 606.1:

WATTS SERIES FBV-3

2 Piece, Full Port Brass Ball Valves (1/4" - 3")

Specifications:

Approved valves shall have bottom loaded, pressure retaining stems, virgin PTFE seats, and full port. Ball shall be chrome plated brass with brass stem. Valves shall be pressure rated at 600 psi WOG (non-shock), 125psi saturated steam. Each valve shall be tested in the opened and closed position by the manufacturer. Valve must conform to MSS-SP-110. The valve shall be a Watts Regulator Company Series FBV-3 (threaded NPT) or FBVS-3 (solder).



Watts Series FBV-3

WATTS SERIES B-6080

2 Piece, Full Port Bronze Ball Valves (1/2" - 2")

Specifications:

Valves shall be 2-piece, full port construction, bronze ASTM B-584 body, electroless nickel plated ASTM B-16 or B-124 brass ball, blow-out proof ASTM B-16 brass stem, Virgin PTFE seats, PTFE stem packing and stem thrust bearing. Valves shall be pressure rated to 150psi (8.6 bars) WSP, 600psi (28 bars) WOG, and either threaded NPT or solder end connections. Valves shall be manufactured to the MSS-SP-110 standard. The valve shall be a Watts Regulator Company B-6080 (threaded) or B-6081 (solder) end.



Watts Series B-6080

WATTS SERIES B-6800

3 Piece, Full Port Brass Ball Valves (1/4" - 2")

Specifications:

Valves shall be 3-piece, full port, in-line maintenance type, constructed of ASTM B-124 brass body, brass ASTM B-16, or B-124 electroless nickel-plated ball, reinforced Durafill seats, reinforced PTFE stem packing and stem thrust bearing, ASTM B-16 brass blow-out proof stem. Valves shall be pressure rated to 150psi (10 bars) WSP, 600psi (41 bars) WOG 1/4" - 1" (8-25 mm), 400 psi (28 bars) WOG 1 1/4" - 2" (32-50 mm); and have either threaded NPT or solder end connections. Valves shall be manufactured to MSS-SP-110. The valve shall be a Watts Regulator Company B-6800 (threaded) or B-6801 (solder) end.

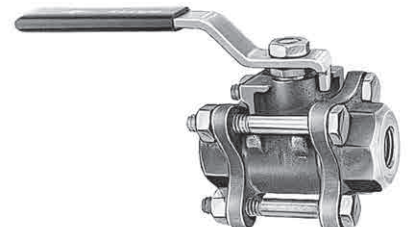

Watts Series B-6800

IPC 2000 Section 606 Installation of the Building Water Distribution System - cont'd.

606.2 Location of shutoff valves. Shutoff valves shall be installed in the following locations:

1. On the fixture supply to each plumbing fixture in other than one- and two-family and multiple-family residential occupancies, and other than in individual guest rooms that are provided with unit shutoff valves in hotels, motels, boarding houses and similar occupancies.
2. On the water supply pipe to each sillcock.
3. On the water supply pipe to each appliance or mechanical equipment.

Applicable Watts Products for IPC Code Section 606.2:

WATTS SERIES FBV-3

2 Piece, Full Port Brass Ball Valves (1/4" - 3")

Specifications:

Approved valves shall have bottom loaded, pressure retaining stems, virgin PTFE seats, and full port. Ball shall be chrome plated brass with brass stem. Valves shall be pressure rated at 600 psi WOG (non-shock), 125psi saturated steam. Each valve shall be tested in the opened and closed position by the manufacturer. Valve must conform to MSS-SP-110. The valve shall be a Watts Regulator Company Series FBV-3 (threaded NPT) or FBVS-3 (solder).



Watts Series FBV-3

WATTS SERIES B-6080

2 Piece, Full Port Bronze Ball Valves (1/2" - 2")

Specifications:

Valves shall be 2-piece, full port construction, bronze ASTM B-584 body, electroless nickel plated ASTM B-16 or B-124 brass ball, blow-out proof ASTM B-16 brass stem, Virgin PTFE seats, PTFE stem packing and stem thrust bearing. Valves shall be pressure rated to 150psi (8.6 bars) WSP, 600psi (28 bars) WOG, and either threaded NPT or solder end connections. Valves shall be manufactured to the MSS-SP-110 standard. The valve shall be a Watts Regulator Company B-6080 (threaded) or B-6081 (solder).



Watts Series B-6080

WATTS SERIES B-6800

3 Piece, Full Port Brass Ball Valves (1/4" - 2")

Specifications:

Valves shall be 3-piece, full port, in-line maintenance type, constructed of ASTM B-124 brass body, brass ASTM B-16, or B-124 electroless nickel-plated ball, reinforced Durafill seats, reinforced PTFE stem packing and stem thrust bearing, ASTM B-16 brass blow-out proof stem. Valves shall be pressure rated to 150 psi (10 bars) WSP, 600psi (41 bars) WOG 1/4" - 1" (8-25 mm), 400psi (28 bars) WOG 1 1/4" - 2" (32-50 mm); and have either threaded NPT or solder end connections. Valves shall be manufactured to MSS-SP-110. The valve shall be a Watts Regulator Company B-6800 (threaded) or B-6801 (solder).

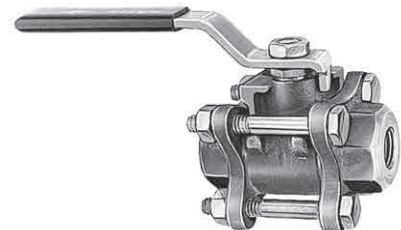

Watts Series B-6800

IPC 2000 Section 606 Installation of the Building Water Distribution System - cont'd.

606.5.1 Water pressure booster systems required. Where the water pressure in the public water main or individual water supply system is insufficient to supply the minimum pressures and quantities specified in this code, the supply shall be supplemented by an elevated water tank, a hydropneumatic pressure booster system or a water pressure booster pump installed in accordance with Section 606.5.5.

Applicable Watts Products for IPC Code Section 606.5.1:

WATTS SERIES 115-AN

Pressure Booster System

Specifications:

Pressure booster system shall have as final pressure control, Watts ACV model 115-AN pressure reducing, pressure sustaining, and check valve. Pressure sustaining control shall be piped to the suction side of the pump. The control system shall be equipped with manual ball valve shut offs to allow field repairs and maintenance in the line, opening and closing speed controls and a pilot system strainer. Main valve shall be cast iron with fused epoxy coating inside and out. When the valve is in the closed position, sealing at the seat shall be accomplished by contact between one edge of a securely retained elastomer quad seal and a smooth seat surface. Seat design shall be removable and not have edges that will induce seal cutting, or wear at low flows. Main valve shaft shall be guided at top and bottom. Valves must have bubble tight shut off. Piston style valves will be unacceptable. The valve shall be a Watts Regulator Company Series 115-AN. Consult your local Watts agent for sizing and application help.

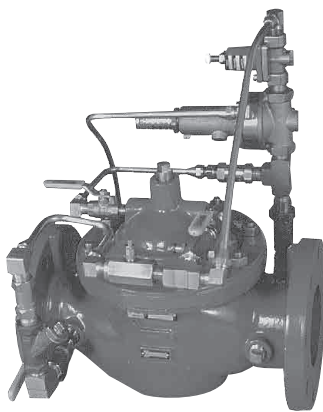

Watts Series 115-AN

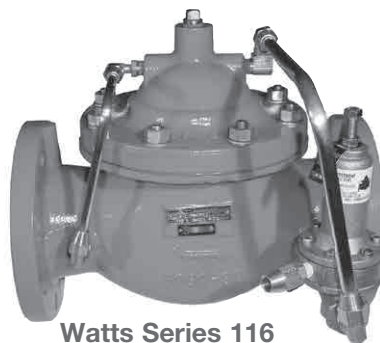

Watts Series 116

WATTS SERIES 116/1116

Water Pressure Reducing Valve (1¹/₄" - 24")

Specifications:

Watts Series 116/1116 installed on a bypass line, main line pressure is accurately controlled by relief of excess pressure. Installed in the main line prevents upstream pressure from dropping below a preset minimum.

Body shall be ductile iron ANSI B16.1 fusion bond epoxy coated, inside and out. Diaphragm actuated by hydraulic pilot. Valves shall be appropriate for dead end service. All elastomers shall be of FDA approved materials. Seat shall be renewable 316 stainless steel. The disc shall be quad seal retained on three sides by the disc holder. Disc holder shall be configured to create a needle valve for smooth laminar flow over the seat when low flows are required. Disc/diaphragm assembly shall be top and bottom guided to assure proper disc/seat alignment. Raised sharp seats will not be accepted. The valve shall be a Watts Regulator Company Series 116/1116. Consult your local Watts agent for sizing and application help.

IPC 2000 Section 606 Installation of the Building Water Distribution System - cont'd.

606.5.9 Pressure tanks, vacuum relief. All water pressure tanks shall be provided with a vacuum relief valve at the top of the tank that will operate up to a maximum water pressure of 200psi (1380 kPa) and up to a maximum temperature of 200°F (93°C). The minimum size of such vacuum relief valve shall be 0.50 inch (12.7 mm).

Exception: This section shall not apply to pressurized captive air diaphragm/bladder tanks.

606.5.10 Pressure relief for tanks. Every pressure tank in a hydropneumatic pressure booster system shall be protected with a pressure relief valve. The pressure relief valve shall be set at a maximum pressure equal to the rating of the tank. The relief valve shall be installed on the supply pipe to the tank or on the tank. The relief valve shall discharge by gravity to a safe place of disposal.

Applicable Watts Products for IPC Code Section 606.5.9:

WATTS SERIES N36

Vacuum Relief Valve (1/2", 3/4")

Specifications:

The valve shall be installed on domestic hot water supply tanks/heaters/unit heaters/steam kettles as indicated on plans. The vacuum relief valve shall be ANSI Z21.22 rated and CSA certified. The vacuum relief valve shall have an all brass body and include a protective cap. The valve shall be a Watts Regulator Company Series N36.



Watts Series N36

Applicable Watts Products for IPC Code Section 606.5.10:

WATTS SERIES 174A

ASME Water Pressure Relief Valve for Residential Applications (3/4" - 2")

Specifications:

An ASME Section IV certified pressure relief valve shall be installed on each pressure tank as noted. The relief valve shall be set to relieve at the maximum working pressure of the tank. The valve shall feature a raised seat and non-mechanical disc alignment. Working parts and spring shall be isolated from any discharge by a high temperature resistant material. Valve shall be a Watts Regulator Company Series 174A.



Watts Series 174A

IPC 2000 Section 607 Hot Water Supply System

607.3 Thermal expansion control. A means of controlling increased pressure caused by thermal expansion shall be provided where required in accordance with Sections 607.3.1 and 607.3.2.

Applicable Watts Products for IPC Code Section 607.3:

WATTS SERIES ILT

In-Line Thermal Expansion Tank

Specifications:

The potable water expansion tank shall be of steel construction. It shall be of flow through design. It shall have a Butyl diaphragm separating the air chamber from the water containment chamber. Inlet and outlet connectors shall be union thread or sweat. Materials of manufacture for diaphragm shall be FDA approved. The potable water expansion tank shall be a Watts Regulator Company Series ILT.



Watts Series ILT

WATTS SERIES DET

Thermal Expansion Tank

Specifications:

The potable water expansion tank shall be of drawn steel construction. It shall have a Butyl diaphragm separating the air chamber from the water containment chamber. Inlet connector shall be brass (Model DET-35: Stainless Steel). Materials of manufacture for the diaphragm shall be FDA approved. The potable water expansion tank shall be a Watts Regulator Company Series DET.



Watts Series DET

WATTS SERIES PET

Thermal Expansion Tank

Specifications:

The potable water expansion tank shall be of drawn steel construction and include a thermally bonded epoxy liner in the water containing area. It shall have a Butyl diaphragm separating the air chamber from the water containment chamber. Inlet connector shall be stainless steel. Materials of manufacture for the liner and diaphragm shall be FDA approved. The potable water expansion tank shall be a Watts Regulator Company Series PET.



Watts Series PET

IPC 2000 Section 608 Protection of Potable Water Supply

608.1 General. A potable water supply system shall be designed, installed and maintained in such a manner so as to prevent contamination from non-potable liquids, solids or gases being introduced into the potable water supply through cross-connections or any other piping connections to the system. Backflow preventer applications shall conform to Table 608.1, except as specifically stated in Sections 608.2 through 608.16.9.

608.2 Plumbing fixtures. The supply lines or fittings for every plumbing fixture shall be installed so as to prevent backflow.

TABLE 608.1
Application for Backflow Preventers

Device	Degree of Hazard^a	Application^b	Applicable Standards
Air gap	High or low	Backsiphonage or backpressure	ASME A112.1.2
Anti-siphon-type water closet flush tank	Low	Backsiphonage only	ASSE 1002 CSA CAN/B125
Barometric Loop	High or low	Backsiphonage only	(See Section 608.13.4)
Reduced pressure principle backflow preventer	High or low	Backpressure or backsiphonage Sizes 3/8" - 16"	ASSE 1013 AWWA C511 CSA CAN / CSA-B64.4
Reduced pressure detector assembly backflow preventer	High or low	Backsiphonage or backpressure (Fire sprinkler systems)	ASSE 1047
Double check backflow prevention assembly	Low	Backpressure or backsiphonage Sizes 3/8" - 16"	ASSE 1015 AWWA C510
Double check detector assembly backflow preventer	Low	Backpressure or backsiphonage (Fire sprinkler systems) Sizes 1 1/2" - 16"	ASSE 1048
Dual-check-valve-type backflow preventer	Low	Backpressure or backsiphonage Sizes 1/4" - 1"	ASSE 1024
Backflow preventer with intermediate atmospheric vents	Low	Backpressure or backsiphonage Sizes 1/4" - 3/4"	ASSE 1012 CSA CAN / CSA-B64.3
Dual-check-valve-type backflow preventer for carbonated beverage dispenser / post mix type	Low	Backpressure or backsiphonage Sizes 1/4" - 3/4"	ASSE1032
Pipe-applied atmospheric-type vacuum breaker	High or low	Backsiphonage only Sizes 1/4" - 4"	ASSE 1001 CSA CAN / CSA B64.1.1
Pressure vacuum breaker assembly	High or low	Backsiphonage only Sizes 1/2" - 2"	ASSE 1020
Hose connection vacuum breaker	High or low	Low head backpressure or backsiphonage Sizes 1/2", 3/4", 1"	ASSE 1011 CSA CAN / CSA B64.2
Vacuum breaker wall hydrants, frost-resistant, automatic draining type	High or low	Low head backpressure or backsiphonage Sizes 3/4", 1"	ASSE 1019 CSA CAN / CSA B64.2.2
Laboratory faucet backflow preventer	High or low	Low head backpressure and backsiphonage	ASSE 1035 CSA B64.7
Hose connection backflow preventer	High or low	Low head backpressure, rated working pressure backpressure or backsiphonage Sizes 1/2" - 1"	ASSE 1052
Spill-proof vacuum breaker	High or low	Backsiphonage only Sizes 1/4" - 2"	ASSE 1056

For SI: One inch = 25.4 mm.

a. Low hazard - See Pollution (Section 202)
High hazard - See Contamination (Section 202)

b. See Backpressure (Section 202)
See Backpressure, Low Head (Section 202)
See Backsiphonage (Section 202)

IPC 2000 Section 608 Protection of Potable Water Supply - cont'd

608.3 Devices, appurtenances, appliances and apparatus. All devices, appurtenances, appliances and apparatus intended to serve some special function, such as sterilization, distillation, processing, cooling, or storage of ice or foods, and that connect to the water supply system, shall be provided with protection against backflow and contamination of the water supply system. Water pumps, filters, softeners, tanks and all other appliances and devices that handle or treat potable water shall be protected against contamination.

Applicable Watts Products for IPC Code Section 608.3:

WATTS SERIES 009

Reduced Pressure Zone Backflow Preventer (1/4" - 3")

Specifications:

A reduced pressure zone backflow preventer shall be installed at each potential health hazard location to prevent backflow due to back-siphonage and/or backpressure. The assembly shall consist of an internal pressure differential relief valve located in a zone between two positive seating check modules with captured springs and silicone seat discs. Seats and seat discs shall be replaceable in both check modules and the relief valve. There shall be no threads or screws in the waterway exposed to line fluids. Service of all internal components shall be through a single access cover secured with stainless steel bolts. The assembly shall also include two resilient seated isolation valves, four resilient seated test cocks and an air gap drain fitting. The assembly shall meet the requirements of: USC Manual 8th Edition; ASSE Standard. 1013; AWWA Standard. C511; CSA B64.4. The valve shall be a Watts Regulator Company Series 009.

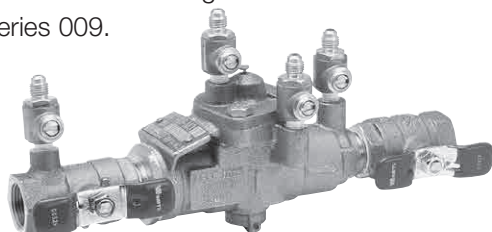

Watts Series 009

WATTS SERIES 288A

Hot or Cold Water Anti-Siphon Vacuum Breaker (1/4" - 3")

Specifications:

An atmospheric-type anti-siphon vacuum breaker shall be installed where indicated on the plans to prevent the backsiphonage of contaminated water. This device is not to be used under continuous pressure or where there is a possibility that a back pressure condition may develop. The device shall meet the requirements of ASSE Standard 1001, ANSI A112.1.1 and CSA B64, and shall be a Watts Regulator Company Series 288A.



Watts Series 288A

WATTS SERIES 800M4FR

Freeze-Resistant Pressure Vacuum Breaker (1/2" - 2")

Specifications:

An anti-siphon pressure vacuum breaker shall be installed where indicated on the plans to prevent the back-siphonage of contaminated water. This assembly is not to be used where there is a possibility that a back pressure condition may develop. The assembly will incorporate an acetal bonnet with silicone rubber O-ring seal and silicone rubber seat disc. The valve shall have replaceable seats. Check assembly shall be guided over its full stroke by 'V' notch guides. The assembly shall include an internal, built-in relief valve designed to protect the internal components and the backflow body from freezing. The relief valve shall be repeatable, automatically re-seating when the pressure within the valve is below the set point of the freeze relief valve. The assembly shall meet the requirements of ANSI/ASSE Standard 1020. The valve shall be a Watts Regulator Company Series 800M4FR.



Watts Series 800M4FR

IPC 2000 Section 608 Protection of Potable Water Supply - cont'd

608.3.1 Special equipment, water supply protection. The water supply for hospital fixtures shall be protected against backflow with a reduced pressure principle backflow preventer, an atmospheric or spill-proof vacuum breaker, or an air gap. Vacuum breakers for bedpan washer hoses shall not be located less than 5 feet (1524 mm) above the floor. Vacuum breakers for hose connections in health care or laboratory areas shall not be less than 6 feet (1829 mm) above the floor.

Applicable Watts Products for IPC Code Section 608.3.1:

WATTS SERIES 009

Reduced Pressure Zone Backflow Preventer (1/4" - 3")

Specifications:

A reduced pressure zone backflow preventer shall be installed at each potential health hazard location to prevent backflow due to backsiphonage and/or backpressure. The assembly shall consist of an internal pressure differential relief valve located in a zone between two positive seating check modules with captured springs and silicone seat discs. Seats and seat discs shall be replaceable in both check modules and the relief valve. There shall be no threads or screws in the waterway exposed to line fluids. Service of all internal components shall be through a single access cover secured with stainless steel bolts. The assembly shall also include two resilient seated isolation valves, four resilient seated test cocks and an air gap drain fitting. The assembly shall meet the requirements of: USC Manual 8th Edition; ASSE Standard 1013; AWWA Standard C511; CSA B64.4. The valve shall be a Watts Regulator Company Series 009.

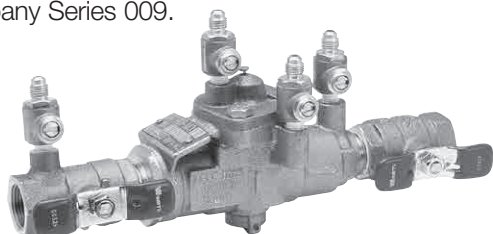

Watts Series 009

WATTS SERIES 288A

Hot or Cold Water Anti-Siphon Vacuum Breaker (1/4" - 3")

Specifications:

An atmospheric-type anti-siphon vacuum breaker shall be installed where indicated on the plans to prevent the backsiphonage of contaminated water. This device is not to be used under continuous pressure or where there is a possibility that a back pressure condition may develop. The device shall meet the requirements of ASSE Standard 1001, ANSI A112.1.1 and CSA B64, and shall be a Watts Regulator Company Series 288A.



Watts Series 288A

WATTS SERIES 008PCQT

Health Hazard Vacuum Breaker, Anti-Siphon, Spill Resistant (3/8" - 1")

Specifications:

A spill-resistant vacuum breaker (SVB) shall be installed, in accordance with the manufacturer's instructions, as noted on the plans. The valve shall consist of a one-piece modular check and float assembly made of engineered thermoplastic and housed in a bronze body. Springs shall be stainless steel. The valve shall be constructed with a molded diaphragm separating the air inlet from the potable water supply to prevent spillage. The valve shall be a Watts Regulator Company Series 008PCQT.

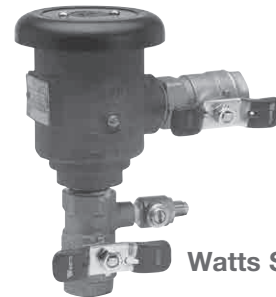

Watts Series 288A

IPC 2000 Section 608 Protection of Potable Water Supply - cont'd

608.13 Backflow protection. Means of protection against backflow shall be provided in accordance with Sections 608.13.1 through 608.13.9.

WATTS SERIES 9D

Backflow Preventer with Intermediate Atmospheric Vent (1/2", 3/4")

Specifications:

A dual check with atmospheric vent shall be installed at referenced cross-connections. Valve shall feature stainless steel and rubber internals protected by an integral strainer. Primary check shall be rubber to rubber

Applicable Watts Products for IPC Code Section 608.13:

seated, backed by the secondary check with rubber to metal seating. The device shall be ASSE approved under Standard 1012 and shall be a Watts Regulator Company Series 9D.



Watts Series 9D

IPC 2000 Section 608 Protection of Potable Water Supply - cont'd

608.13.2 Reduced pressure principle backflow preventers. Reduced pressure principle backflow preventers shall conform to ASSE 1013, AWWA C511 or CSA CAN/CSA B64.3. Reduced pressure detector assembly backflow preventers shall conform to ASSE 1047. These devices shall be permitted to be installed where subject to continuous pressure conditions. The relief opening shall discharge by air gap and shall be prevented from being submerged.

WATTS SERIES 909

Reduced Pressure Zone Backflow Preventer (3/4" - 10")

Specifications:

A reduced pressure zone backflow preventer shall be installed at each cross connection to prevent backsiphonage and back-pressure backflow of hazardous materials into the potable water supply. The assembly shall consist of a pressure differential relief valve located in a zone between two positive seating check valves. Backsiphonage protection shall include provision to admit air directly into the reduced pressure zone via a separate channel from the water discharge channel, or directly into the supply pipe via a separate vent. The assembly shall include two resilient seated shutoff valves before and

Applicable Watts Products for IPC Code Section 608.13.2:

after the assembly, test cocks and a protective strainer upstream of the No.1 shutoff valve. The assembly (specify Model 909 for temperatures up to 140°F (60°C) or Model 909HW for temperatures up to 210°F (99°C)) shall meet the requirements of ASSE Standard 1013; AWWA Standard C-511-92 CSA B64.4; FCCCHR of USC Manual Section 10. Listed by IAPMO (UPC). SBCCI (Standard Plumbing code). The valve shall be a Watts Regulator Company Series 909QT or 909QTHW.

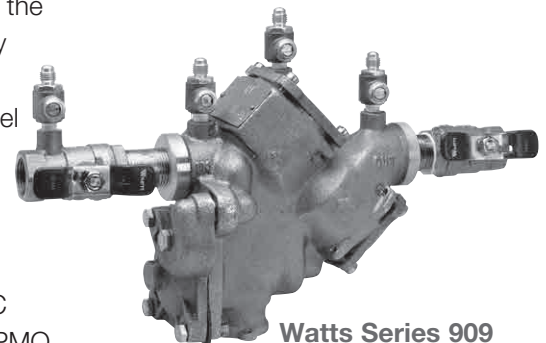

Watts Series 909

continued on following page

IPC 2000 Section 608 Protection of Potable Water Supply - cont'd

608.13.2 Reduced pressure principle backflow preventers - cont'd

WATTS SERIES 009

Reduced Pressure Zone Backflow Preventer (1/4" - 3")

Specifications:

A reduced pressure zone backflow preventer shall be installed at each potential health hazard location to prevent backflow due to back-siphonage and/or backpressure. The assembly shall consist of an internal pressure differential relief valve located in a zone between two positive seating check modules with captured springs and silicone seat discs. Seats and seat discs shall be replaceable in both check modules and the relief valve. There shall be no threads or screws in the water-way exposed to line fluids. Service

Applicable Watts Products for IPC Code Section 608.13.2 - cont'd

of all internal components shall be through a single access cover secured with stainless steel bolts. The assembly shall also include two resilient seated isolation valves, four resilient seated test cocks and an air gap drain fitting. The assembly shall meet the requirements of: USC Manual 8th Edition; ASSE Standard 1013; AWWA Standard C511; CSA B64.4. The valve shall be a Watts Regulator Company Series 009.

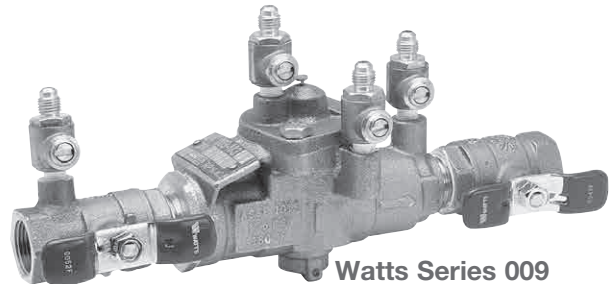

Watts Series 009

IPC 2000 Section 608 Protection of Potable Water Supply - cont'd

608.13.3 Backflow preventer with intermediate atmospheric vent. Backflow preventers with intermediate atmospheric vents shall conform to ASSE 1012 or CSA CAN/ CSA-1364.3. These devices shall be permitted to be installed where subject to continuous pressure conditions. The relief opening shall discharge by air gap and shall be prevented from being submerged.

WATTS SERIES 9D

Backflow Preventer with Intermediate Atmospheric Vent (1/2", 3/4")

Specifications:

A dual check with atmospheric vent shall be installed at referenced cross-connections. Valve shall feature stainless steel and rubber internals protected by an integral strainer. Primary check shall be rubber to rubber seated, backed by the

Applicable Watts Products for IPC Code Section 608.13.3:

secondary check with rubber to metal seating. The device shall be ASSE approved under Standard 1012 and shall be a Watts Regulator Company Series 9D.



Watts Series v9D

IPC 2000 Section 608 Protection of Potable Water Supply - cont'd

608.13.5 Pressure-type vacuum breakers. Pressure-type vacuum breakers shall conform to ASSE 1020 and spillproof vacuum breakers shall comply with ASSE 1056. These devices are designed for installation under continuous pressure conditions when the critical level is installed at the required height. Pressure-type vacuum breakers shall not be installed in locations where spillage could cause damage to the structure.

Applicable Watts Products for IPC Code Section 608.13.5:

WATTS SERIES 800M4QT

Anti-siphon Pressure Vacuum Breakers (1/2" - 2")

Specifications:

A pressure anti-siphon vacuum breaker shall be installed where indicated on the plans to prevent the back siphonage of contaminated water. This assembly is not to be used where there is a possibility that a back pressure condition may develop. The assembly will incorporate an acetal bonnet with silicone rubber O-ring seal and silicone rubber seat disc. The valve shall have replaceable seats. Check assembly shall be guided over its full stroke by 'V' notch guides. The assembly shall meet the requirements of ANSI/ASSE Standard 1020. The valve shall be a Watts Regulator Company Series 800M4QT.



Watts Series 800M4QT

WATTS SERIES 008PCQT

Health Hazard Vacuum Breaker, Anti-Siphon, Spill Resistant (3/8" - 1")

Specifications:

A spill-resistant vacuum breaker (SVB) shall be installed, in accordance with the manufacturer's instructions, as noted on the plans. The valve shall consist of a one-piece modular check and float assembly made of engineered thermoplastic and housed in a bronze body. Springs shall be stainless steel. The valve shall be constructed with a molded diaphragm separating the air inlet from the potable water supply to prevent spillage. The valve shall be a Watts Regulator Company Series 008PCQT.



Watts Series 008PCQT

IPC 2000 Section 608 Protection of Potable Water Supply - cont'd

608.13.6 Atmospheric-type vacuum breakers. Pipe applied atmospheric-type vacuum breakers shall conform to ASSE 1001 or CSA CAN/CSA-B64.1.1. Hose-connection vacuum breakers shall conform to ASSE 1011, ASSE 1019, ASSE 1035, ASSE 1052, CSA CAN/CSA-B64.2, CSA CAN/CSA-B64.2.2 or CSA B64.7. These devices shall operate under normal atmospheric pressure when the critical level is installed at the required height.

Applicable Watts Products for IPC Code Section 608.13.6:

WATTS SERIES 288A

Hot or cold Water Anti-Siphon Vacuum Breaker (1/4" - 3")

Specifications:

An atmospheric-type anti-siphon vacuum breaker shall be installed where indicated on the plans to prevent the backsiphonage of contaminated water. This device is not to be used under continuous pressure or where there is a possibility that a back pressure condition may develop. The device shall meet the requirements of ASSE Standard 1001, ANSI A112.1.1 and CSA B64, and shall be a Watts Regulator Company Series 288A.



Watts Series 288A

WATTS SERIES 8

Hose Connection Vacuum Breakers (3/4" - 3")

Specifications:

A hose connection type anti-siphon vacuum breaker shall be installed where indicated on the plans to prevent the back-siphonage of contaminated water. This device is not to be used under continuous pressure or where there is a possibility that a back pressure condition may develop. This device shall meet the requirements of ANSI A112.1.3, ASSE Standard 1011. The valve shall be a Watts Regulator Company Series 8.



Watts Series 8

IPC 2000 Section 608 Protection of Potable Water Supply - cont'd

608.13.7 Double check-valve assemblies. Double check-valve assemblies shall conform to ASSE 1015 or AWWA C510. Double-detector check-valve assemblies shall conform to ASSE 1048. These devices shall be capable of operating under continuous pressure conditions.

Applicable Watts Products for IPC Code Section 608.13.7:

WATTS SERIES 007

Double Check Valve Assembly (1/2" - 3")

Specifications:

A double check valve backflow preventer shall be installed at each noted location. The assembly shall consist of two positive seating check modules with captured springs and rubber seat discs. The check module seats and seat discs shall be replaceable. Service of all internal components shall be through a single access cover secured with stainless steel bolts. The assembly shall also include two resilient seated isolation valves; four top mounted, resilient seated test cocks. The assembly shall meet the requirements of ASSE Standard 1015 and AWWA Standard C510. Approved by the Foundation for Cross-Connection Control and Hydraulic Research at the University of Southern California. The valve shall be a Watts Regulator Company Series 007.



Watts Series 007

WATTS SERIES 709

Double Check Valve Backflow Preventer (2 1/2" - 10")

Specifications:

A double check valve backflow preventer shall be installed at referenced cross-connections to prevent the backflow of polluted water into the potable water supply. The cross-connections shall be determined by local inspection authority for use where a high hazard situation does not exist. Valve shall feature modular check assemblies with center stem guiding. Each check module shall have a captured spring and be accessible through a bolted cover plate. Seats shall be replaceable without special tools. It shall be a complete assembly including tight-closing resilient seated shutoff valves, test cocks, and a strainer is recommended. The assembly shall meet the requirements of ASSE No. 1015; AWWA C510-92; CSA B64.5 and UL Classified File No. EX3185. Approved by the Foundation for Cross-Connection Control and Hydraulic Research at the University of Southern California. The valve shall be a Watts Regulator Company

Series 709.



Watts Series 709

WATTS SERIES 709DCDA

Double Check Detector Assembly Backflow Preventer (3", 4", 6", 8", 10")

Specifications:

A double check detector assembly backflow preventer shall be installed on fire protection systems when connected to a potable water supply. Degree of hazard present is determined by the local authority having jurisdiction. The unit shall be a complete assembly including UL listed resilient seated OS&Y shutoff valves and test cocks. The unit shall be UL/FM approved with UL/FM approved OS&Y shutoff valves. The auxiliary line shall consist of an approved backflow preventer and water meter. The assembly shall meet the basic requirements of ASSE 1048; AWWA Standard C510 for Double Check Valves. Approved by the Foundation for Cross-Connection Control and Hydraulic Research at the University of Southern California. The valve shall be a Watts Regulator Company Series 709DCDA OSY.

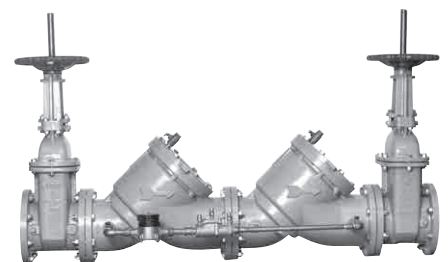

Watts Series 709DCDA

continued on following page

IPC 2000 Section 608 Protection of Potable Water Supply - cont'd

608.13.7 Double check-valve assemblies - cont'd.

Applicable Watts Products for IPC Code Section 608.13.7 - cont'd

WATTS SERIES 774

Double Check Valve Backflow Preventer (4"-12")

Specifications:

A double check valve backflow preventer shall be installed at each noted location to prevent the unwanted reversal of polluted water into the potable water supply. The main valve body shall be manufactured from 300 series stainless steel to provide corrosion resistance. The check valves shall be of thermoplastic construction with stainless steel hinge pins, cam arm, and cam bearing. The check valves shall utilize a single torsion spring design to minimize pressure drop through the assembly. The check valves shall be modular and shall seal to the main valve body by the use of an O-ring. There shall be no brass or bronze parts used within the check valve assembly. The valve cover shall be held in place through the use of a single grooved style two-bolt coupling. The main assembly shall consist of two independently operating torsion spring check assemblies, two resilient seated isolation valves, and four ball valve type test cocks. The assembly shall be a Watts Regulator Company Series 774.

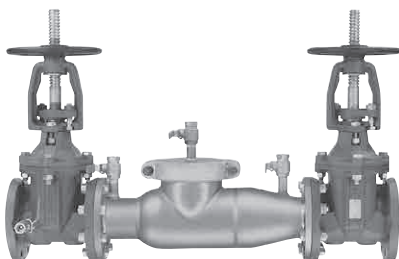

Watts Series 774

WATTS SERIES 774DCDA

Double Check Detector Assembly (4"-12")

Specifications:

A double check detector assembly-backflow Preventer shall be installed on fire protection systems when connected to a potable water supply. Degree of hazard present is determined by the local authority having jurisdiction. The assembly shall consist of two positive seating check valves located between two resilient seated shutoffs with a hydraulically balanced bypass line and four test cocks. The main valve body shall be manufactured from 300 Series stainless steel to provide corrosion resistance. The check valves shall be of thermoplastic construction with stainless steel hinge pins, cam arm and cam bearing. The check valves shall utilize a single torsion spring design to minimize pressure drop through the assembly. The check valves shall be modular and shall seal to the main valve body by the use of an O-ring. There shall be no brass or bronze parts used within the check valve assembly. The check valve seats shall be of molded thermoplastic construction. The use of

seat screws as a retention method is prohibited. All internal parts shall be accessible through a single cover on the valve assembly. The valve cover shall be held in place through the use of a single grooved style two-bolt coupling. The bypass line shall be hydraulically sized to accurately measure low flow. The by-pass line shall consist of a meter, a small diameter double check assembly with test cocks and isolation valves. The bypass line double check valve shall have a single access cover, two independently operating modular poppet check valves, and top mounted test cocks. The assembly shall be a Watts Regulator Company Series 774DCDA.

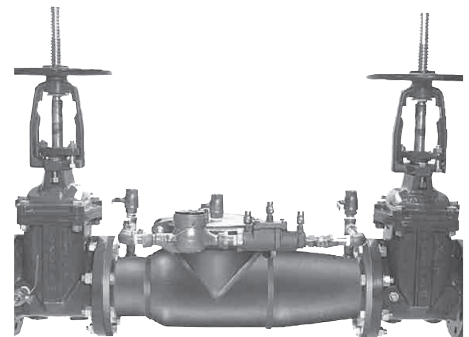

Watts Series 774DCDA

IPC 2000 Section 608 Protection of Potable Water Supply - cont'd

608.13.8 Spill-proof vacuum breakers. Spill-proof vacuum breakers (SVB) shall conform to ASSE 1056. These devices are designed for installation under continuous pressure conditions when the critical level is installed at the required height.

WATTS SERIES 008PCQT

Applicable Watts Products for IPC Code Section 608.13.8:

Health Hazard Vacuum Breaker, Anti-Siphon, Spill Resistant ($3/8''$ - $1''$)

Specifications:

A spill-resistant vacuum breaker (SVB) shall be installed, in accordance with the manufacturer's instructions, as noted on the plans. The valve shall consist of a one-piece modular check and float assembly made of engineered thermoplastic and housed in a bronze body. Springs shall be stainless steel. The valve shall be con-

structed with a molded diaphragm separating the air inlet from the potable water supply to prevent spillage. The valve shall be a Watts Regulator Company Series 008PCQT.



Watts Series 008PCQT

IPC 2000 Section 608.14 Location of Backflow Preventers

608.14 Location of backflow preventers. Access shall be provided to backflow preventers as specified by the installation instructions of the approved manufacturer.

608.14.1 Outdoor enclosures for backflow prevention devices. Outdoor enclosures for backflow prevention devices shall comply with ASSE 1060.

Applicable Watts Products for IPC Code Section 608.14.1:

WATTS SERIES WB Insulated Enclosures

Specifications:

Backflow preventer assemblies subjected to potential freezing conditions shall be protected with the WattsBox enclosure as shown in the accompanying plan. Enclosure shall be designed for 12" clearance between valve and grade. The enclosure shall be of reinforced aluminum or fiberglass construction, providing access through doors and/or a hinged lid for testing/certification purposes. It must also be totally removable for maintenance purposes. The enclosure shall be structurally lined with a unicellular, non-wicking insulation consisting of a sandwich laminate or applied by spray. It shall contain a thermostatically controlled heat source mounted to the interior wall or on the backflow preventer to provide protection to -30°F. No wood or "particle board" shall be allowed in assembly. Insulation mounted with glue will be cause for rejection. Power source will be protected with a ground fault circuit interrupting receptacle, UL Standard 943, NEMA 3R, installed by others, inside the box. The enclosure shall contain drain openings sized to accommodate the maximum discharge of the reduced pressure assembly. Drain openings shall open to discharge under the most severe conditions. These openings are protected against intrusion of either wind, debris or animal. The enclosure

is provided with means of permanent anchor and "lockable" access doors and/or lid to prohibit theft or vandalism. The enclosure shall be factory assembled and delivered to the site ready to install with no drilling, screwing or riveting of enclosure required on site. The enclosure and the backflow preventer shall be covered by a single warranty policy. The enclosure shall be a Watts Regulator Company Series WB.

WATTS SERIES WB-T Tall Insulated Enclosures

Specifications:

Backflow prevention assemblies subjected to potential freezing conditions shall be protected with the WattsBox enclosure as shown in the accompanying plan. The enclosure shall be of reinforced aluminum or fiberglass construction, providing access through doors and/or a hinged lid for testing/certification purposes. It must also be totally removable for maintenance purposes. The enclosure shall be structurally lined with a unicellular, non-wicking insulation consisting of a sandwich laminate or applied by spray. It shall contain a thermostatically controlled heat source mounted to the interior wall or on the backflow preventer to provide protection to -30°F. No wood

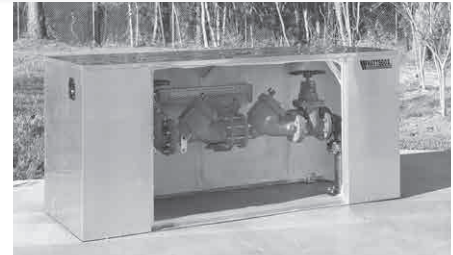

Watts Series WB

or "particle board" shall be allowed in assembly. Insulation mounted with glue will be cause for rejection. Power source will be protected with a ground fault circuit interrupting receptacle, UL Standard 943, NEMA 3R, installed by others, inside the box. The enclosure shall contain drain openings sized to accommodate the maximum discharge of the reduced pressure assembly. Drain openings shall open to discharge under the most severe conditions. These openings are protected against intrusion of either wind, debris or animals. The enclosure is provided with means of permanent anchor and "lockable" access doors and/or lid to prohibit theft or vandalism. All "wet" portions of the backflow prevention assembly shall be protected within the enclosure. Fire department hose connections and OS&Y indicating valve handles shall be maintained outside the enclosure. The enclosure and the backflow preventer shall be covered by a single warranty policy. The enclosure shall be a Watts Regulator Company Series WB-T.

IPC 2000 Section 608 Protection of Potable Water Outlets

608.15 Protection of potable water outlets. All potable water openings and outlets shall be protected against backflow in accordance with Section 608.15.1, 608.15.2, 608.15.3, 608.15.4, 608.15.4.1, 608.15.4.2 or 608.15.4.3.

608.15.2 Protection by a reduced pressure principle backflow preventer. Openings and outlets shall be protected by a reduced pressure principle backflow preventer.

Applicable Watts Products for IPC Code Section 608.15.2:

WATTS SERIES 009

Reduced Pressure Zone Backflow Preventer (1/4" - 3")

Specifications:

A reduced pressure zone backflow preventer shall be installed at each potential health hazard location to prevent backflow due to backsiphonage and/or backpressure. The assembly shall consist of an internal pressure differential relief valve located in a zone between two positive seating check modules with captured springs and silicone seat discs. Seats and seat discs shall be replaceable in both check modules and the relief valve. There shall be no threads or screws in the waterway exposed to line fluids. Service of all internal components shall be through a single access cover secured with stainless steel bolts. The assembly shall also include two resilient seated isolation valves, four resilient seated test cocks and an air gap drain fitting. The assembly shall meet the requirements of: USC Manual 8th Edition; ASSE Standard 1013; AWWA Standard C511; CSA B64.4. The valve shall be a Watts Regulator Company Series 009.



Watts Series 009

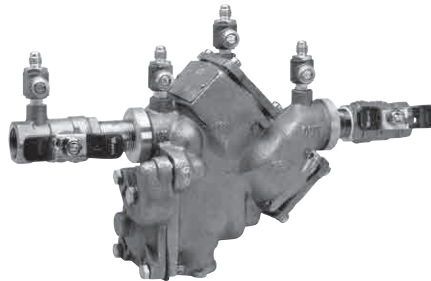

Watts Series 909

WATTS SERIES 909

Reduced Pressure Zone Backflow Preventer (3/4" - 2")

Specifications:

A reduced pressure zone backflow preventer shall be installed at each cross connection to prevent backsiphonage and back-pressure backflow of hazardous materials into the potable water supply. The assembly shall consist of a pressure differential relief valve located in a zone between two positive seating check valves. Backsiphonage protection shall include provision to admit air directly into the reduced pressure zone via a separate channel from the water discharge channel, or directly into the supply pipe via a separate vent. The assembly shall include two resilient seated shutoff valves before and after the assembly, test cocks and a protective strainer upstream of the No. 1 shutoff valve. The assembly (specify Model 909 for temperatures up to 140°F (60°C) or Model 909HW for temperatures up to 210°F (99°C)) shall meet the requirements of ASSE Standard 1013; AWWA Standard C-511-92 CSA B64.4; FCCCHR of USC Manual Section 10. Listed by IAPMO (UPC), SBCCI (Standard Plumbing code). The valve shall be a Watts Regulator Company Series 909QT or 909QTHW.

IPC 2000 Section 608.15 Protection of Potable Water Outlets - cont'd

608.15.3 Protection by a backflow preventer with intermediate atmospheric vent. Openings and outlets shall be protected by a backflow preventer with an intermediate atmospheric vent.

608.15.4 Protection by a vacuum breaker. Openings and outlets shall be protected by atmospheric-type or pressure-type vacuum breakers. The critical level of the vacuum breaker shall be set a minimum of 6 inches (152 mm) above the flood level rim of the fixture or device. Ball cocks shall be set in accordance with Section 425.4.1 Vacuum breakers shall not be installed under exhaust hoods or similar locations that will contain toxic fumes or vapors. Pipe-applied vacuum breakers shall be installed not less than 6 inches (152 mm) above the flood level rim of the fixture, receptor or device served.

608.15.4.2 Hose connections. Sillcocks, hose bibbs, wall hydrants and other openings with a hose connection shall be protected by an atmospheric-type or pressure-type vacuum breaker or a permanently attached hose connection vacuum breaker.

Applicable Watts Products for IPC Code Section 608.15.3:

WATTS SERIES 9D

**Backflow Preventer
with Intermediate Atmospheric
Vent (1/2", 3/4")**

Specifications:

A dual check with atmospheric vent shall be installed at referenced cross-connections. Valve shall feature stainless steel and rubber internals protected by an integral strainer. Primary check shall be rubber to rubber seated, backed by the secondary check with rubber to metal seating. The device shall be ASSE approved under Standard. 1012 and shall be a Watts Regulator Company Series 9D.



Watts Series 9D

Applicable Watts Products for IPC Code Section 608.15.4:

WATTS SERIES 288A

**Hot or cold Water Anti-Siphon
Vacuum Breaker (1/4" - 3")**

Specifications:

An atmospheric-type anti-siphon vacuum breaker shall be installed where indicated on the plans to prevent the backsiphonage of contaminated water. This device is not to be used under continuous pressure or where there is a possibility that a back pressure condition may develop. The device shall meet the requirements of ASSE Standard 1001, ANSI A112.1.1 and CSA B64, and shall be a Watts Regulator Company Series 288A.



Watts Series 288A

Applicable Watts Products for IPC Code Section 608.15.4.2

WATTS SERIES 8

**Hose Connection
Vacuum Breakers**

Specifications:

A hose connection type anti-siphon vacuum breaker shall be installed where indicated on the plans to prevent the back-siphonage of contaminated water. This device is not to be used under continuous pressure or where there is a possibility that a back pressure condition may develop. This device shall meet the requirements of ANSI A112.1.3, ASSE Standard 1011. The valve shall be a Watts Regulator Company Series 8.



Watts Series 8

IPC 2000 Section 608.15 Protection of Potable Water Outlets - cont'd

608.15.4.2 Hose connections - cont'd

WATTS SERIES 008PCQT

Health Hazard Vacuum Breaker, Anti-Siphon, Spill Resistant (3/8" - 1")

Specifications:

A spill-resistant vacuum breaker (SVB) shall be installed, in accordance with the manufacturer's instructions, as noted on the plans. The valve shall consist of a one-piece modular check and float assembly made of engineered thermoplastic and housed in a bronze body. Springs shall be stainless steel. The

Applicable Watts Products for IPC Code Section 608.15.4.2 - cont'd

valve shall be constructed with a molded dia-phragm separating the air inlet from the potable water supply to prevent spillage. The valve shall be a Watts Regulator Company Series 008PCQT.



Watts Series 008PCQT

IPC 2000 Section 608.16 Connections to the Potable Water System

608.16 Connections to the potable water system. Connections to the potable water system shall conform to Sections 608.16.1 through 608.16.9.

608.16.1 Beverage dispensers. The water supply connection to carbonated beverage dispensers shall be protected against backflow by a double check valve with an intermediate atmospheric vent conforming to ASSE 1012 or ASSE 1022. The double check valve with an intermediate atmospheric vent device and the piping downstream therefrom shall not be affected by carbon dioxide gas. Secondary protection in the form of a dual check valve conforming to ASSE 1032 shall be installed on the beverage-dispensing equipment.

WATTS SERIES SD-3

Backflow Preventer for Carbonated Beverage Machines (1/2", 3/8")

Specifications:

Backflow preventer body and adapters shall be 316 stainless steel construction and all rubber components shall comply with FDA food additive regulations. All materials in contact with the potable water shall be in compliance with the requirements of

Applicable Watts Products for IPC Code Section 608.16.1:

the Safe Drinking Water Act, Public Law 93-523, National Interim Primary Drinking Water Regulations. Strainer shall be manufactured from NSF approved acetal plastic. The valve shall be a Watts Regulator Company Series SD-3.



Watts Series SD-3

IPC 2000 Section 608 Connections to the Potable Water System - cont'd

608.16.2 Connections to boilers. The potable supply to the boiler shall be equipped with a backflow preventer with an intermediate atmospheric vent complying with ASSE 1012 or CSA CAN/CSA B64.3. Where conditioning chemicals are introduced into the system, the potable water connection shall be protected by an air gap or a reduced pressure principle backflow preventer, complying with ASSE 1013, CSA CAN/CSA B64.4 or AWWA C51 1.

Applicable Watts Products for IPC Code Section 608.16.2:

WATTS SERIES 9D

Backflow Preventer with Intermediate Atmospheric Vent (1/2", 3/4")

Specifications

A dual check with atmospheric vent shall be installed at referenced cross-connections. Valve shall feature stainless steel and rubber internals protected by an integral strainer. Primary check shall be rubber to rubber seated, backed by the secondary check with rubber to metal seating. The device shall be ASSE approved under Standard 1012 and shall be a Watts Regulator Company Series 9D.



Watts Series 9D

WATTS SERIES 909

Reduced Pressure Zone Backflow Preventer (3/4" - 2")

Specifications:

A reduced pressure zone backflow preventer shall be installed at each cross connection to prevent backsiphonage and back-pressure backflow of hazardous materials into the potable water supply. The assembly shall consist of a pressure differential relief valve located in a zone between two positive seating check valves. Backsiphonage protection shall include provision to admit air directly into the reduced pressure zone via a separate channel from the water discharge channel, or directly into the supply pipe via a separate vent. The assembly shall include two resilient seated shutoff valves before and after the assembly, test cocks and a protective strainer upstream of the No. 1 shutoff valve. The assembly (specify Model 909 for temperatures up to 140°F (60°C) or Model 909HW for temperatures up to 210°F (99°C)) shall meet the requirements of ASSE Standard 1013; AWWA Standard C-511-92 CSA B64.4; FCCCHR of USC Manual Section 10. Listed by IAPMO (UPC). SBCCI (Standard Plumbing code). The valve shall be a Watts Regulator Company Series 909QT or 909QTHW.

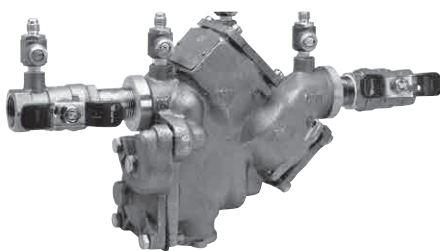

Watts Series 909

WATTS SERIES 009

Reduced Pressure Zone Backflow Preventer (1/4" - 3")

Specifications:

A reduced pressure zone backflow preventer shall be installed at each potential health hazard location to prevent backflow due to backsiphonage and/or backpressure. The assembly shall consist of an internal pressure differential relief valve located in a zone between two positive seating check modules with captured springs and silicone seat discs. Seats and seat discs shall be replaceable in both check modules and the relief valve. There shall be no threads or screws in the waterway exposed to line fluids. Service of all internal components shall be through a single access cover secured with stainless steel bolts. The assembly shall also include two resilient seated isolation valves, four resilient seated test cocks and an air gap drain fitting. The assembly shall meet the requirements of: USC Manual 8th Edition; ASSE Standard 1013; AWWA Standard C511; CSA B64.4. The valve shall be a Watts Regulator Company Series 009.

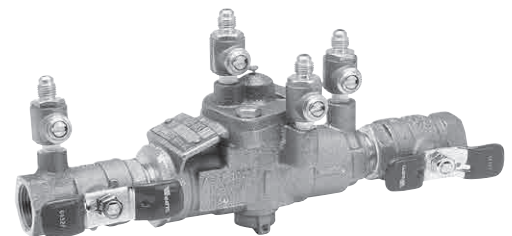

Watts Series 009

IPC 2000 Section 608 Connections to the Potable Water System - cont'd

608.16.4 Connections to automatic fire sprinkler systems and standpipe systems. The potable water supply to automatic fire sprinkler and standpipe systems shall be protected against backflow by a double check-valve assembly or a reduced pressure principle backflow preventer.

Exceptions:

1. Where systems are installed as a portion of the water distribution system in accordance with the requirements of this code and are not provided with a fire department connection, isolation of the water supply system shall not be required.
2. Isolation of the water distribution system is not required for deluge, preaction or dry pipe systems.

Applicable Watts Products for IPC Code Section 608.16.4:

WATTS SERIES 007

Double Check Valve Assembly (1/2" - 3")

Specifications:

A double check valve backflow preventer shall be installed at each noted location. The assembly shall consist of two positive seating check modules with captured springs and rubber seat discs. The check module seats and seat discs shall be replaceable. Service of all internal components shall be through a single access cover secured with stainless steel bolts. The assembly shall also include two resilient seated isolation valves; four top mounted, resilient seated test cocks. The assembly shall meet the requirements of ASSE Standard 1015 and AWWA Standard C510. Approved by the Foundation for Cross-Connection Control and Hydraulic Research at the University of Southern California. The valve shall be a Watts Regulator Company Series 007.

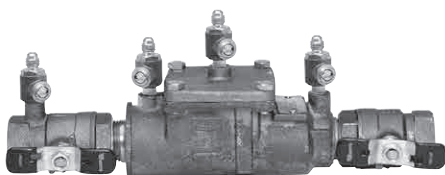

Watts Series 007

WATTS SERIES 007DCDA

Double Check Detector Assembly (2"-3")

Specifications:

A double check detector assembly backflow preventer shall be installed on fire protection systems when connected to a potable water supply. Degree of hazard present is determined by the local authority having jurisdiction. The backflow preventer shall be a complete assembly including UL listed resilient seated OS&Y shutoff valves and four test cocks. The test cocks located on the backflow preventer shall be mounted at the top of the valve to reduce clearance problems and to assist in the evacuation of air from the assembly. The assembly shall consist of two independently operating modular poppet-type check valves. The check valves shall utilize captured springs and shall have replaceable seats. The checks shall be double-guided, both along the outside edge of the check module and through the center stem assembly. The seats shall be replaceable without the use of special tools. Seat retention shall be done by the use of an interlocking bayonet style cage and the use of

threaded seats or seat screws is prohibited. Access to the internal check assemblies shall be via a single top entry cover. The cover shall be securely held in place by stainless steel bolts. Where applicable the unit shall be FM approved with FM approved OS&Y resilient seated shut-off valves. The assembly shall include an auxiliary bypass line consisting of an approved backflow preventer and water meter. The assembly shall be listed or approved under the requirements of ASSE Standard. 1048, AWWA Standard. C510-92 and CSA B64.5. Approved by the Foundation for Cross-Connection Control and Hydraulic Research at the University of Southern California. The assembly shall be a Watts Regulator Company Series 007DCDA.

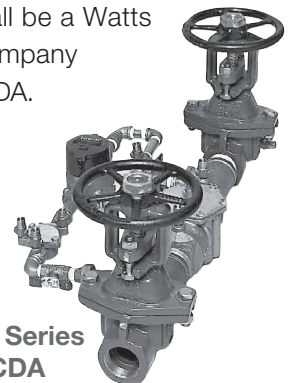

Watts Series
007DCDA

continued on following page

IPC 2000 Section 608 Connections to the Potable Water System - cont'd

608.16.4 Connections to automatic fire sprinkler systems and standpipe systems

Applicable Watts Products for IPC Code Section 608.16.4 - cont'd

WATTS SERIES 709

Double Check Valve Backflow Preventer (2¹/₂" - 10")

Specifications:

A double check valve backflow preventer shall be installed at referenced cross-connections to prevent the backflow of polluted water into the potable water supply. The cross-connections shall be determined by local inspection authority for use where a high hazard situation does not exist. Valve shall feature modular check assemblies with center stem guiding. Each check module shall have a captured spring and be accessible through a bolted cover plate. Seats shall be replaceable without special tools. It shall be a complete assembly including tight-closing resilient seated shutoff valves, test cocks, and a strainer is recommended. The assembly shall meet the requirements of ASSE No. 1015; AWWA C510-92; CSA B64.5 and UL Classified File No. EX3185. Approved by the Foundation for Cross-Connection Control and Hydraulic Research at the University of Southern California. The valve shall be a Watts Regulator Company Series 709.



Watts Series 709

WATTS SERIES 709DCDA

Double Check Detector Assembly Backflow Preventer (3", 4", 6", 8", 10")

Specifications:

A double check detector assembly backflow preventer shall be installed on fire protection systems when connected to a potable water supply. Degree of hazard present is determined by the local authority having jurisdiction. The unit shall be a complete assembly including UL listed resilient seated OS&Y shutoff valves and test cocks. The unit shall be UL/FM approved with UL/FM approved OS&Y shutoff valves. The auxiliary line shall consist of an approved backflow preventer and water meter. The assembly shall meet the basic requirements of ASSE 1048; AWWA Standard C510 for Double Check Valves. Approved by the Foundation for Cross-Connection Control and Hydraulic Research at the University of Southern California. The valve shall be a Watts Regulator Company Series 709DCDA OSY.

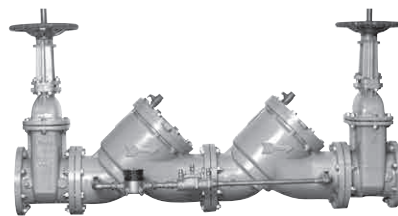

Watts Series 709DCDA

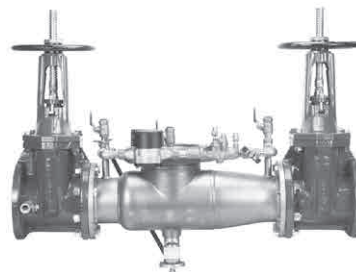

Watts Series 995RPDA

WATTS SERIES 995RPDA

Reduced Pressure Detector Assembly (3"-6")

Specifications:

A reduced pressure zone assembly backflow preventer shall be installed at each noted location to prevent the unwanted reversal of hazardous water into the potable water supply. The main valve shall be manufactured from 300 Series stainless steel to provide corrosion resistance and eliminate corrosion due to pitting of epoxy coated valves. The check valves shall be of thermo-plastic construction with stainless steel hinge pins, cam bearing, and center pivot arm. The check valves shall have reversible check disc rubber and use a single torsion spring design to minimize pressure drop through the assembly. The check valves shall be modular and shall be threaded into the main valve body to insure a positive seal. There shall be no brass or bronze parts used within the check valve assembly. The valve cover shall be held in place through the use of a single grooved style two-bolt coupling and gasket / diaphragm. The use of special gaskets/O-rings to seal the cover and body interface is not allowed. The relief valve shall use a dual purpose cover gasket and relief valve diaphragm to separate inlet pressure from zone pressure. The relief valve shall include a bulk-head-mounted seat to insure that the relief valve seat threads are not exposed to line fluid. The main assembly shall consist of two independently operating torsion spring check assemblies, two resilient seated isolation valves, an in-line style relief valve, a hydraulically balanced bypass line and four ball valve type test cocks. The backflow prevention assembly shall be a Watts Regulator Company Series 995RPDA.

IPC 2000 Section 608 Connections to the Potable Water System - cont'd

608.16.4.1 Additives or non-potable source. Where systems contain chemical additives or antifreeze, or where systems are connected to a non-potable secondary water supply, the potable water supply shall be protected against backflow by a reduced pressure principle backflow preventer. Where chemical additives or antifreeze are added to only a portion of an automatic fire sprinkler or standpipe system, the reduced pressure principle backflow preventer shall be permitted to be located so as to isolate that portion of the system.

WATTS SERIES 909

Reduced Pressure Zone Backflow Preventer (3/4" - 10")

Specifications:

A reduced pressure zone backflow preventer shall be installed at each cross connection to prevent backsiphonage and back-pressure backflow of hazardous materials into the potable water supply. The assembly shall consist of a pressure differential relief valve located in a zone between two positive seating check valves. Backsiphonage protection shall include provision to admit air directly into the reduced pressure zone via a separate channel from the water discharge channel, or directly into the supply pipe via a separate vent. The assembly shall include two resilient seated shutoff valves before

Applicable Watts Products for IPC Code Section 608.16.4.1:

and after the assembly, test cocks and a protective strainer upstream of the No. 1 shutoff valve. The assembly (specify Model 909 for temperatures up to 140°F (60°C) or Model 909HW for temperatures up to 210°F (99°C)) shall meet the requirements of ASSE Standard 1013; AWWA Standard C-511-92 CSA B64.4; FCCCHR of USC Manual Section 10. Listed by IAPMO (UPC), SBCCI (Standard Plumbing code). The valve shall be Watts Regulator Company Series 909QT or 909QTHW.

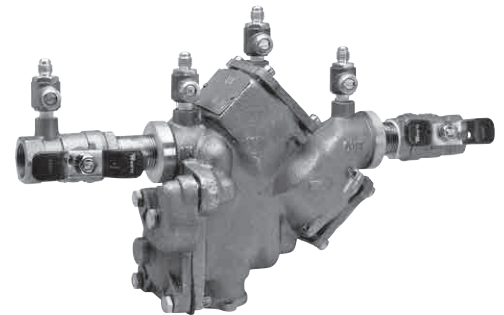

Watts Series 909

OTHER APPLICABLE WATTS PRODUCTS FOR IPC CODE SECTION 608.16.4.1

Valve Type	Model	Sizes (in.)	Applicable Standards
Double Check Detector Assemblies	774DCDA	4 - 12	ASSE Std.1048
	774XDCDA	6 - 8	ASSE Std. 1048
	775DCDA	3 - 8	ASSE Std. 1048
Double Check Valve Assemblies	774OSY	4 - 12	ASSE Std. 1015, AWWA C510-97
	774XOSY	6 - 8	ASSE Std. 1015, AWWA C510-97
	775OSY	3 - 8	ASSE Std. 1015, AWWA C510-97, IAMPO PS31
Reduced Pressure Zone Backflow Preventers	909OSY	2 1/2 - 10	ASSE Std. 1013, AWWA C511-97, CSA B64.4, IAMPO PS31
	994OSY	2 1/2 - 10	ASSE Std. 1013, AWWA C511-97, IAMPO PS31
	995OSY	3 - 6	ASSE Std. 1013, AWWA C511-97, IAMPO PS31
Reduced Pressure Detector Assemblies	909RPDA	2 1/2 - 10	CSA B64.4
	994RPDA	4 - 6	ASSE Std. 1047, AWWA C511-92, CSA B64.5
	995RPDA	3 - 6	ASSE Std. 1047, CSA B64.4

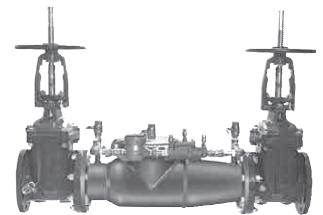

Watts Series 774DCDA

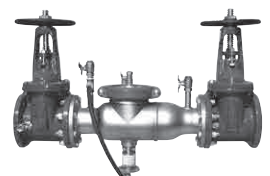

Watts Series 994OSY

IPC 2000 Section 608 Connections to the Potable Water System - cont'd

608.16.5 Connections to lawn irrigation systems. The potable water supply to lawn irrigation systems shall be protected against backflow by an atmospheric-type vacuum breaker, a pressure-type vacuum breaker or a reduced pressure principle backflow preventer. A valve shall not be installed downstream from an atmospheric vacuum breaker. Where chemicals are introduced into the system, the potable water supply shall be protected against backflow by a reduced pressure principle backflow preventer.

Applicable Watts Products for IPC Code Section 608.16.5:

WATTS SERIES 800M4FR

Freeze-Resistant Pressure Vacuum Breaker (1/2" - 2")

Specifications:

An anti-siphon pressure vacuum breaker shall be installed where indicated on the plans to prevent the back-siphonage of contaminated water. This assembly is not to be used where there is a possibility that a back pressure condition may develop. The assembly will incorporate an acetal bonnet with silicone rubber O-ring seal and silicone rubber seat disc. The valve shall have replaceable seats. Check assembly shall be guided over its full stroke by 'V' notch guides. The assembly shall include an internal, built-in relief valve designed to protect the internal components and the backflow body from freezing. The relief valve action shall be repeatable, automatically re-seating when the pressure within the valve is below the set point of the freeze relief valve. The assembly shall meet the requirements of ANSI/ASSE Standard 1020. The valve shall be a Watts Regulator Company Series 800M4FR.



Watts Series 800M4FR

WATTS SERIES 800M4QT

Anti-siphon Pressure Vacuum Breakers (1/2" - 2")

Specifications:

A pressure anti-siphon vacuum breaker shall be installed where indicated on the plans to prevent the back siphonage of contaminated water. This assembly is not to be used where there is a possibility that a back pressure condition may develop. The assembly will incorporate an acetal bonnet with silicone rubber O-ring seal and silicone rubber seat disc. The valve shall have replaceable seats. Check assembly shall be guided over its full stroke by 'V' notch guides. The assembly shall meet the requirements of ANSI/ASSE Standard 1020. The valve shall be a Watts Regulator Company Series 800M4QT.



Watts Series 800M4QT

IPC 2000 Section 608 Connections to the Potable Water System - cont'd

608.16.5 Connections to lawn irrigation systems - cont'd

Applicable Watts Products for IPC Code Section 608.16.5 - cont'd

WATTS SERIES 909

Reduced Pressure Zone Backflow Preventer (3/4" - 2")

Specifications:

A reduced pressure zone backflow preventer shall be installed at each cross connection to prevent backsiphonage and back-pressure backflow of hazardous materials into the potable water supply. The assembly shall consist of a pressure differential relief valve located in a zone between two positive seating check valves. Back-siphonage protection shall include provision to admit air directly into the reduced pressure zone via a separate channel from the water discharge channel, or directly into the supply pipe via a separate vent. The assembly shall include two resilient seated shutoff valves before and after the assembly, test cocks and a protective strainer upstream of the No. 1 shutoff valve. The assembly (specify Model 909 for temperatures up to 140°F (60°C) or Model 909HW for temperatures up to 210°F (99°C)) shall meet the requirements of ASSE Standard 1013; AWWA Standard C-511-92 CSA B64.4; FCCCHR of USC Manual Section 10. Listed by IAPMO (UPC). SBCCI (Standard Plumbing code). The valve shall be a Watts Regulator Company Series 909QT or 909QTHW.

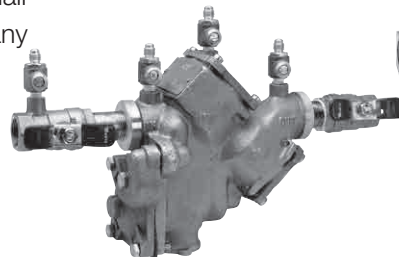

Watts Series 909

WATTS SERIES 009

Reduced Pressure Zone Backflow Preventer (1/4" - 3")

Specifications:

A reduced pressure zone backflow preventer shall be installed at each potential health hazard location to prevent backflow due to backsiphonage and/or backpressure. The assembly shall consist of an internal pressure differential relief valve located in a zone between two positive seating check modules with captured springs and silicone seat discs. Seats and seat discs shall be replaceable in both check modules and the relief valve. There shall be no threads or screws in the waterway exposed to line fluids. Service of all internal components shall be through a single access cover secured with stainless steel bolts. The assembly shall also include two resilient seated isolation valves, four resilient seated test cocks and an air gap drain fitting. The assembly shall meet the requirements of: USC Manual 8th Edition; ASSE Standard 1013; AWWA Standard C511; CSA B64.4. The valve shall be a Watts Regulator Company Series 009.



Watts Series 009

WATTS SERIES 008PCQT

Health Hazard Vacuum Breaker, Anti-Siphon, Spill Resistant (3/8" - 1")

Specifications:

A spill-resistant vacuum breaker (SVB) shall be installed, in accordance with the manufacturer's instructions, as noted on the plans. The valve shall consist of a one-piece modular check and float assembly made of engineered thermoplastic and housed in a bronze body. Springs shall be stainless steel. The valve shall be constructed with a molded dia-phragm separating the air inlet from the potable water supply to prevent spillage. The valve shall be a Watts Regulator Company Series 008PCQT that shall meet the requirements of ASSE 1056.



Watts Series 008PCQT

IPC 2000 Section 608 Connections to the Potable Water System - cont'd

608.16.6 Connections subject to back pressure. Where a potable water connection is made to a non-potable line, fixture, tank, vat, pump or other equipment subject to back pressure, the potable water connection shall be protected by a reduced pressure principle backflow preventer.

Applicable Watts Products for IPC Code Section 608.16.6:

WATTS SERIES 009

Reduced Pressure Zone Backflow Preventer (1/4" – 3")

Specifications:

A reduced pressure zone backflow preventer shall be installed at each potential health hazard location to prevent backflow due to backsiphonage and/or backpressure. The assembly shall consist of an internal pressure differential relief valve located in a zone between two positive seating check modules with captured springs and silicone seat discs. Seats and seat discs shall be replaceable in both check modules and the relief valve. There shall be no threads or screws in the waterway exposed to line fluids. Service of all internal components shall be through a single access cover secured with stainless steel bolts. The assembly shall also include two resilient seated isolation valves, four resilient seated test cocks and an air gap drain fitting. The assembly shall meet the requirements of: USC Manual 8th Edition; ASSE Standard 1013; AWWA Standard C511; CSA B64.4. The valve shall be a Watts Regulator Company Series 009.

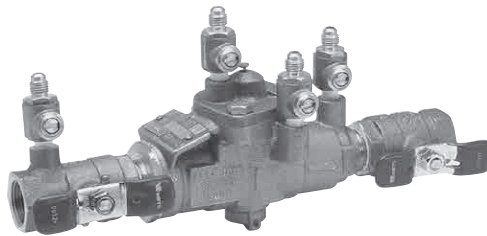

Watts Series 009

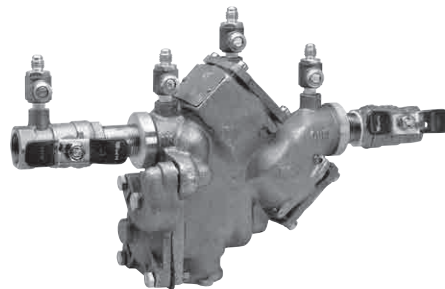

Watts Series 909

WATTS SERIES 909

Reduced Pressure Zone Backflow Preventer (3/4" – 10")

Specifications:

A reduced pressure zone backflow preventer shall be installed at each cross connection to prevent backsiphonage and back-pressure backflow of hazardous materials into the potable water supply. The assembly shall consist of a pressure differential relief valve located in a zone between two positive seating check valves. Backsiphonage protection shall include provision to admit air directly into the reduced pressure zone via a separate channel from the water discharge channel, or directly into the supply pipe via a separate vent. The assembly shall include two resilient seated shutoff valves before and after the assembly, test cocks and a protective strainer upstream of the No. 1 shutoff valve. The assembly (specify Model 909 for temperatures up to 140°F (60°C) or Model 909HW for temperatures up to 210°F (99°C)) shall meet the requirements of ASSE Standard 1013; AWWA Standard C-511-92 CSA B64.4; FCCCHR of USC Manual Section 10. Listed by IAPMO (UPC). SBCCI (Standard Plumbing code). The valve shall be a Watts Regulator Company Series 909QT or 909QTHW.

IPC 2000 Section 608 Connections to the Potable Water System - cont'd

608.16.6 Connections subject to back pressure - cont'd

Applicable Watts Products for IPC Code Section 608.16.6 - cont'd

WATTS SERIES 994

Reduced Pressure Zone Assembly (2¹/₂" - 10")

Specifications:

A reduced pressure zone assembly shall be installed at each cross-connection to prevent backsiphonage and backpressure of hazardous materials into the potable water supply. The assembly shall consist of a pressure differential relief valve located in a zone between two positive seating check valves. The main valve body shall be manufactured from 300 Series stainless steel for corrosion resistance. The check valves shall be of thermoplastic construction with stainless steel hinge pins, cam arm, and cam bearing. The check valve shall utilize a single torsion spring design to minimize pressure drop through the assembly. The check valves shall be modular and shall seal to the main valve body by the use of an O-ring. There shall be no brass or

bronze parts used within the check assembly or relief valve. The use of seat screws to retain the check valve seat is prohibited. All internal parts shall be accessible through a single cover on the valve assembly securely held in place by a two-bolt grooved coupling. The differential relief valve shall be of stainless steel construction and shall utilize a rolling diaphragm and no sliding seals. The relief valve shall be bottom mounted and supplied with a steel reinforced sensing hose. The assembly shall include two resilient seated shutoff valves and four ball type test cocks. The assembly shall be a Watts Regulator Company Series 994 which complies to ASSE Standard 1013.

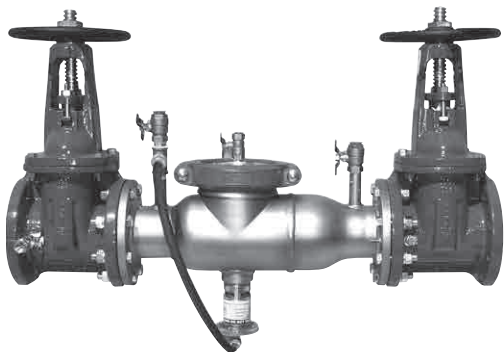

Watts Series 994

IPC 2000 Section 608 Connections to the Potable Water System - cont'd

608.16.7 Chemical dispensers. Where chemical dispensers connect to the potable water distribution system, the water supply system shall be protected against backflow in accordance with Section 608.13.1, 608.13.2, 608.13.3, 608.13.5, 608.13.6, 608.13.8 or 608.13.9.

608.16.8 Portable cleaning equipment. Where the portable cleaning equipment connects to the water distribution system, the water supply system shall be protected against backflow in accordance with Section 608.13.1, 608.13.2, 608.13.3, 608.13.7 or 608.13.8.

608.16.9 Dental pump equipment. Where dental pumping equipment connects to the water distribution system, the water supply system shall be protected against backflow in accordance with Section 608.13.1, 608.13.5, 608.13.6 or 608.13.8.

Applicable Watts Products for IPC Code Section 608.16.7:

WATTS SERIES 008PCQT

Health Hazard Vacuum Breaker, Anti-Siphon, Spill Resistant ($3/8"$ - $1"$)

Specifications:

A spill-resistant vacuum breaker (SVB) shall be installed, in accordance with the manufacturer's instructions, as noted on the plans. The valve shall consist of a one-piece modular check and float assembly made of engineered thermoplastic and housed in a bronze body. Springs shall be stainless steel. The valve shall be constructed with a molded diaphragm separating the air inlet from the potable water supply to prevent spillage. The valve shall be a Watts Regulator Company Series 008PCQT.



Watts Series 008PCQT

For Applicable Watts Products that
apply to Sections 608.16.7, 608.16.8
and 608.16.9 refer back to:

IPC Code Section	Page No.
608.13.3	28
608.13.5	29
608.13.7	31
608.13.8	33

IPC 2000 Section 1002 Trap Requirements

1002.4 Trap seals. Each fixture trap shall have a liquid seal of not less than 2 inches (51 mm) and not more than 4 inches (102 mm), or deeper for special designs relating to accessible fixtures. Where a trap seal is subject to loss by evaporation, a deep-seal trap consisting of a 4-inch (102 mm) seal or trap seal primer valve shall be installed. A trap seal primer valve shall conform to ASSE 1018 or ASSE 1044.

WATTS SERIES A200

Flow-Through Trap Primer (1/2")

Specifications:

A trap primer shall be installed in plumbing systems to prevent floor drain traps from losing their water seal by evaporation. Maintaining the water seal will prevent the backflow of sewer gas into the buildings or rooms where the traps are installed. Trap primers are specified in various plumbing codes such as IAPMO, Southern Standard Building Code,

Applicable Watts Products for IPC Code Section 1002.4:

National Standard Plumbing Code and many state and local plumbing codes in U.S.A. and Canada. The device shall meet the requirements of ASSE Standard 1018. The trap primer shall be a Watts Regulator Company Series A200T (threaded), or A200S (solder).



Watts Series A200

For Technical Assistance Call Your Authorized Watts Agent.

			Telephone #	Fax #
	HEADQUARTERS: Watts Regulator Company	815 Chestnut St., North Andover, MA 01845-6098 U.S.A.	978 688-1811	978 794-1848
North East	Vernon Bitzer Associates, Inc.	980 Thomas Drive, Warminster, PA 18974	215 443-7500	215 443-7573
	Edwards, Platt & Deely, Inc.	271 Royal Ave., Hawthorne, NJ 07506	973 427-2898	973 427-4246
	Edwards, Platt & Deely, Inc.	368 Wyandanch Ave., North Babylon, NY 11703	631 253-0600	631 253-0303
	J. B. O'Connor Company, Inc.	P.O. Box 12927, Pittsburgh, PA 15241	724 745-5300	724 745-7420
	The Joyce Agency, Inc.	8442 Alban Rd., Springfield, VA 22150	703 866-3111	703 866-2332
	W. P. Haney Co., Inc.	51 Norfolk Ave., South Easton, MA 02375	508 238-2030	508 238-8353
	WMS Sales, Inc. (Main office)	9580 County Rd., Clarence Center, NY 14032	716 741-9575	716 741-4810
South East	Billingsley & Associates, Inc.	5609-D Salmen St., Harahan, LA 70123	504 733-7624	504 733-6904
	Billingsley & Associates, Inc.	478 Cheyenne Lane, Madison, MS 39110	601 856-7565	601 856-8390
	Francisco J. Ortiz & Co., Inc.	Charlyn Industrial Pk., Road 190 KM1.9 - Lot #8, Carolina, Puerto Rico 00983	787 769-0085	787 750-5120
	Mid-America Marketing, Inc.	2776 B.M. Montgomery St., Birmingham, AL 35209	205 879-3469	205 870-5027
	Mid-America Marketing, Inc.	1364 Foster Avenue, Nashville, TN 37210	615 259-9944	615 259-5111
	Mid-America Marketing, Inc.	5466 Old Hwy. 78, Memphis, TN 38118	901 795-0045	901 795-0394
	RMI	Glenfield Bus. Ctr., 2535 Mechanicsville Tpk., Richmond, VA 23223	804 643-7355	804 643-7380
	Smith & Stevenson Co., Inc.	4935 Chastain Ave., Charlotte, NC 28217	704 525-3388	704 525-6749
	Spotswood Associates, Inc.	6235 Atlantic Blvd., Norcross, GA 30071	770 447-1227	770 263-6899
	Target Marketing Enterprises, Inc.	118 West Grant St., Building M, Orlando, FL 32806	407 245-7838	407 245-7833
South Central	Hugh M. Cunningham, Inc.	13755 Benchmark, Dallas, TX 75234	972 888-3800	972 888-3838
	Mack McClain & Associates	11132 South Towne Square, Suite 202, St. Louis, MO 63123	314 894-8188	314 894-8388
	Mack McClain & Associates, Inc.	1537 Ohio St., Des Moines, IA 50314	515 288-0184	515 288-5049
	Mack McClain & Associates, Inc.	15090 West 116th St., Olathe, KS 66062	913 339-6677	913 339-9518
	Phoenix Marketing, Ltd.	2416 Candelaria N.E., Albuquerque, NM 87107	505 883-7100	505 883-7101
Pro-Spec, Inc.	P.O. Box 472226, Tulsa, OK 74147-2226	918 461-0066	918 461-0105	
North Central	Associated Independent Marketing	1606 Commerce Dr., Sun Prairie, WI 53590	608 837-5005	608 837-2368
	Dave Watson Associates	1325 West Beecher, Adrian, MI 49221	517 263-8988	517 263-2328
	Disney-McLane-Woodcock, Inc.	428 McGregor Ave., Cincinnati, OH 45206	800 542-1682	877 476-1682
	Disney-McLane-Woodcock, Inc.	17610 S. Waterloo Rd., Cleveland, OH 44119	216 486-1010	216 486-2860
Mid-Continent Marketing Services Ltd.	1724 Armitage Ct., Addison, IL 60101	630 953-1211	630 953-1067	
South West	Delco Sales, Inc.	2267 Yates Ave., Los Angeles, CA 90040	323 890-9250	323 724-5227
	P I R Sales, Inc.	3050 North San Marcos Place, Chandler, AZ 85225	480 892-6000	480 892-6096
	R. C. Hartnett & Associates	30852 Huntwood Ave., Hayward, CA 94544	510 471-7200	510 471-4441
North West	Delco Sales, Inc.	111 Sand Island Access Rd., Unit I-10, Honolulu, HI 96819	808 842-7900	808 842-9265
	Fanning & Associates, Inc.	6765 Franklin St., Denver, CO 80229-7111	303 289-4191	303 286-9069
	Hollabaugh Brothers & Associates	1260 6th Ave. South, Seattle, WA 98134-1308	206 467-0346	206 467-8368
	Hollabaugh Brothers & Associates	3028 S.E. 17th Ave., Portland, OR 97202	503 238-0313	503 235-2824
	R. E. Fitzpatrick Sales, Inc.	4109 West Nike Dr. (8250 South), West Jordan, UT 84088	801 282-0700	801 282-0600
	Soderholm & Associates, Inc.	7150 143rd Ave. N.W., Anoka, MN 55303	763 427-9635	763 427-5665
CANADA	Watts Industries (Canada) Inc. (Watts Regulator Co. Division)	5435 North Service Road, Burlington, Ontario L7L 5H7	905 332-4090	905 332-7068
	GTA Sales Team.	Greater Toronto Area	888 208-8927	888 479-2887
	Hydro-Mechanical Sales, Ltd.	3700 Joseph Howe Dr., Ste. 1 Halifax, Nova Scotia B3L 4H7	902 443-2274	902 443-2275
	Hydro-Mechanical Sales, Ltd.	297 Collishaw St., Ste. 7 (shipping) Moncton, New Brunswick E1C 9R2	506 859-1107	506 859-2424
	Hydro-Mechanical Sales, Ltd.	85 Tolt Rd., St. Phillips, Newfoundland A1B 3M7	709 895-0090	709 895-0091
	Le Groupe B.G.T., Inc.	2800 Rue Dalton Ste. 3, Ste-Foy, Quebec G1P 3S4	418 657-2800	418 657-2700
	Le Groupe B.G.T., Inc.	140 Rue Merizzi, Ville St. Laurent, Quebec H4T 1S4	514 341-9010	514 341-4464
	Walmar Mechanical Sales	24 Gurdwara Rd., Nepean, Ontario K2E 8B5	613 225-9774	613 225-0673
	Mar-Win Agencies, Ltd.	1123 Empress St., Winnipeg, Manitoba R3E 3H1	204 775-8194	204 786-8016
	Palsler Enterprises, Ltd.	1885 Blue Heron Dr., #4, London, Ontario N6H 5L9	519 471-9382	519 471-1049
	Northern Mechanical Sales	P.O. Box 280 (mailing) 163 Pine St. (shipping), Garson, Ontario P3L 1S6	705 693-2715	705 693-4394
	RAM Mechanical Marketing	441 Quebec St., Regina, Saskatchewan S4R 1K8	306 525-1986	306 525-0809
	RAM Mechanical Marketing	2615-B Wentz Avenue, Saskatoon, Saskatchewan S7K 5J1	306 244-6622	306 244-0807
	Con-Cur West Marketing, Inc.	#109-42 Fawcett Rd., Coquitlam, British Columbia V3K 6X9	604 540-5088	604 540-5084
	D.C. Sales, Ltd.	10-6130 4th St. S.E., Calgary, Alberta T2H 2A6	403 253-6808	403 259-8331
D.C. Sales, Ltd.	11420 142 Street, Edmonton, Alberta T5M 1V1	780 496-9495	780 496-9621	
0213	EXPORT Hdqtrs.: Watts Regulator Co.	815 Chestnut St., North Andover, MA 01845-6098 U.S.A.	978 688-1811	978 794-1848



USA: Tel: (978) 689-6066 • Fax: (978) 975-8350 • Watts.com

Canada: Tel: (905) 332-4090 • Fax: (905) 332-7068 • Watts.ca

Latin America: Tel: (52) 81-1001-8600 • Watts.com