

Engineering Specification

Job Name _____

Contractor _____

Job Location _____

Approval _____

Engineer _____

Contractor's P.O. No. _____

Approval _____

Representative _____

FD-910 Parking Deck Drain for Precast Slabs

Specification

Watts FD-910 epoxy coated cast iron parking deck drain with integral countersunk deck flange, 15 1/2" round top with secured ductile iron heel proof grate, gasket seal between body and top assembly, an no hub (standard) outlet.

Call customer service if you need assistance with technical details.

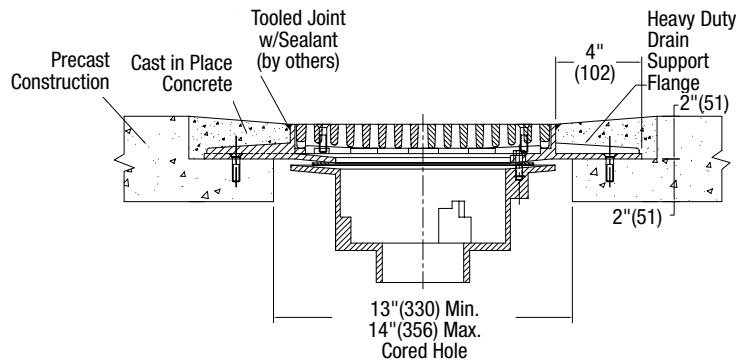
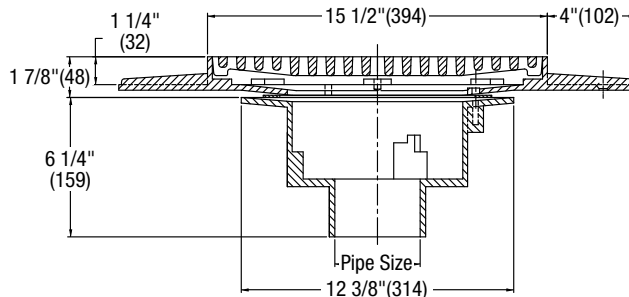

Pipe Sizing		
Suffix	Description	
2	2"(51) Pipe Size	<input type="checkbox"/>
3	3"(76) Pipe Size	<input type="checkbox"/>
4	4"(102) Pipe Size	<input type="checkbox"/>
5	5"(127) Pipe Size (NH Only)	<input type="checkbox"/>
6	6"(152) Pipe Size	<input type="checkbox"/>
8	8"(203) Pipe Size (NH Only)	<input type="checkbox"/>

Outlet Type		
Suffix	Description	
NH	No Hub (MJ)	<input type="checkbox"/>
P	Push On	<input type="checkbox"/>
T	Threaded Outlet	<input type="checkbox"/>
X	Inside Caulk	<input type="checkbox"/>

Options		
Suffix	Description	
-5	Sediment Bucket	<input type="checkbox"/>
-6	Vandal Proof	<input type="checkbox"/>
-13	Galvanized Body	<input type="checkbox"/>
-D	Underdeck Clamp	<input type="checkbox"/>
-SB	Shallow Body 2 3/4" Deep (3, 4, 6" NH/P, 8" NH)	<input type="checkbox"/>

Load Rating	Free Area Sq. In.
XHD	61

NOTICE

The load classifications are in accordance with the American National Standard ASME A112.21.1M ASME Ratings are as follows:
XHD Safe Live Load 7500-10,000 lbs. (3375-4500 kg)
The above categories are given as a guide only. Please consult factory.

NOTICE

The information contained herein is not intended to replace the full product installation and safety information available or the experience of a trained product installer. You are required to thoroughly read all installation instructions and product safety information before beginning the installation of this product.

Watts product specifications in U.S. customary units and metric are approximate and are provided for reference only. For precise measurements, please contact Watts Technical Service. Watts reserves the right to change or modify product design, construction, specifications, or materials without prior notice and without incurring any obligation to make such changes and modifications on Watts products previously or subsequently sold.



USA: T: (800) 338-2581 • Watts.com
Canada: T: (888) 208-8927 • Watts.ca
Latin America: T: (52) 55-4122-0138 • Watts.com

