

Engineering Specification

Job Name _____
 Job Location _____
 Engineer _____
 Approval _____

Contractor _____
 Approval _____
 Contractor's P.O. No. _____
 Representative _____

CA-100-EXT Closet Carrier Auxiliary Support

Specification

Watts CA-100-EXT auxiliary water closet support with epoxy coated cast iron uprights and supporting plate assembly, and 24" long ABS nipple with integral test cap.

Call customer service if you need assistance with technical details.

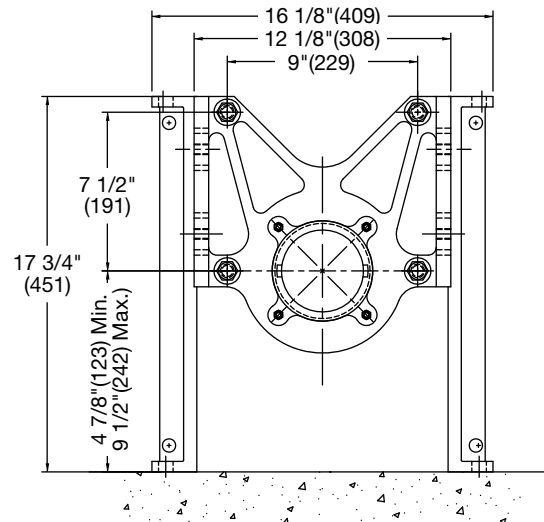
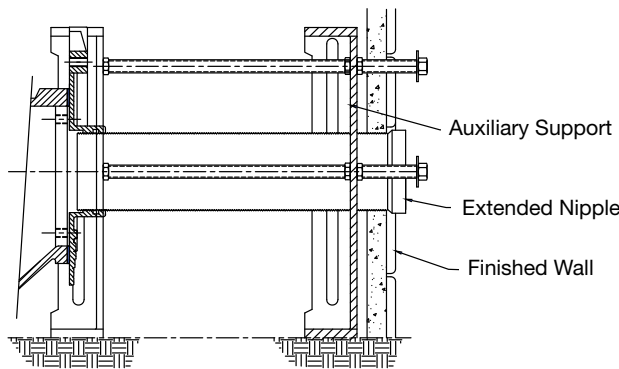
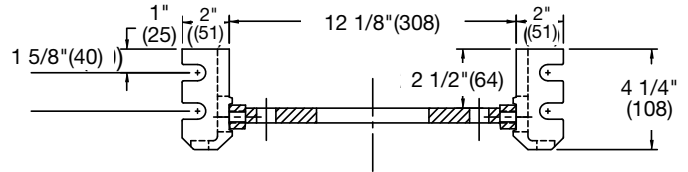

NOTICE

All foot supports must be securely anchored to concrete floor with min. 1/2"(13) anchors with pull-out force of 500 lbs.(227 kg). Dual slotted carrier feet require one 1/2"(13) anchor bolt per foot.

NOTICE

The information contained herein is not intended to replace the full product installation and safety information available or the experience of a trained product installer. You are required to thoroughly read all installation instructions and product safety information before beginning the installation of this product.

Watts product specifications in U.S. customary units and metric are approximate and are provided for reference only. For precise measurements, please contact Watts Technical Service. Watts reserves the right to change or modify product design, construction, specifications, or materials without prior notice and without incurring any obligation to make such changes and modifications on Watts products previously or subsequently sold.



USA: T: (800) 338-2581 • Watts.com
 Canada: T: (888) 208-8927 • Watts.ca
 Latin America: T: (52) 55-4122-0138 • Watts.com

